

HIGH POWER INDUCTOR**P7601 Family****Features**

- * High Current (to 16A rms)
- * Very Low DCR (to 2mΩ)
- * Low profile (5-8mm)
- * Surface Mount
- * Flat top for pick & place
- * Pb-free

Applications

- * DC-DC Converters
- * High Current/Low Voltage Converters
- * Voltage Regulator Modules
- * Notebook and handheld equipment

DESCRIPTION

The P7601 family comprises high current, unshielded power inductors.

Components are available in three mechanical sizes, suitable for low-profile high current applications.

The miniature 1813 parts have very high current rating for their size; the 3316 and 5022 parts exhibit very low DCR.

The family employs heavy gauge wire to minimize DCRs, and provides reliable self-leaded Pb-free terminations suitable for Pb-free and conventional placement and reflow.

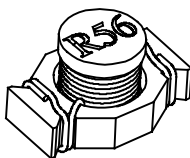

P7601-1813

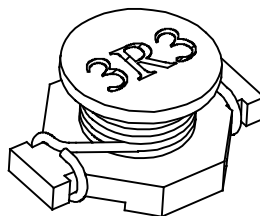

P7601-3316

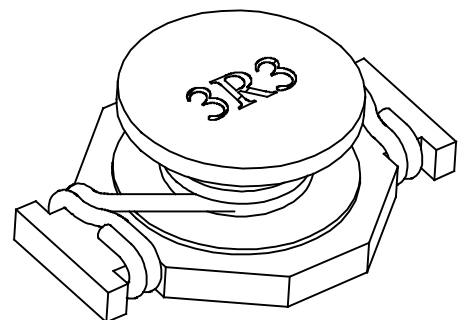

P7601-5022

SPECIFICATIONS

Electrical

Part Number	Inductance (μH) ⁽¹⁾	DCR (m Ω) Max	SRF (MHz) ⁽²⁾	Rated Current I _{RMS} (A) ⁽³⁾	I _{sat} (A) ⁽⁴⁾
P7601-1813-R56M	0.56±20%	10	200	6.0	7.7
P7601-1813-1R2M	1.2±20%	17	140	4.4	5.3
P7601-1813-2R2M	2.2±20%	35	100	3.1	3.5
P7601-1813-4R7M	4.7±20%	54	50	2.2	2.6
P7601-1813-100M	10±20%	111	40	1.5	1.9
P7601-1813-150M	15±20%	170	30	1.2	1.5
P7601-1813-220M	22±20%	250	25	1.0	1.2
P7601-1813-330M	33±20%	350	20	0.8	1.0
P7601-1813-470M	47±20%	470	15	0.7	0.9
P7601-3316-R33M	0.33±20%	2	300	16	20
P7601-3316-R68M	0.68±20%	5	200	12	13
P7601-3316-1R0M	1.0±20%	6	100	10	11
P7601-3316-1R5M	1.5±20%	8	90	9	9
P7601-3316-2R2M	2.2±20%	11	90	7.4	7.8
P7601-3316-2R7M	2.7±20%	12	65	6.6	7.0
P7601-3316-3R3M	3.3±20%	14	65	5.9	6.4
P7601-3316-4R7M	4.7±20%	18	45	4.8	5.9
P7601-3316-5R6M	5.6±20%	22	40	4.6	5.0
P7601-3316-6R8M	6.8±20%	27	36	4.4	4.6
P7601-3316-8R2M	8.2±20%	32	28	4.0	4.0
P7601-3316-100M	10±20%	38	25	3.9	3.8
P7601-5022-R78M	0.78±20%	2.6	156	15	30
P7601-5022-1R5M	1.5±20%	4	100	15	25
P7601-5022-2R2M	2.2±20%	6	75	12	20
P7601-5022-3R3M	3.3±20%	8	60	10	17
P7601-5022-3R9M	3.9±20%	10	55	9	15
P7601-5022-4R7M	4.7±20%	14	40	8.4	13
P7601-5022-6R0M	6.0±20%	17	35	7.5	12
P7601-5022-7R8M	7.8±20%	18	35	7.5	11
P7601-5022-100M	10±20%	26	28	6.0	10
P7601-5022-150M	15±20%	32	20	4.4	8

Notes

1. Inductance measured at 100kHz, 100mV (P7601-1813 100kHz, 250mV).
2. SRF (Self Resonant Frequency) is typical and for reference only.
3. Rated current is the current at which the temperature rise is 40°C. (max).
4. Saturation current, I_{sat}, is the DC current at which the zero-current inductance drops by 10% (typ).
5. Operating temperature -40°C to +85°C.
6. For non-standard inductance values, please contact Profec.

CONSTRUCTION

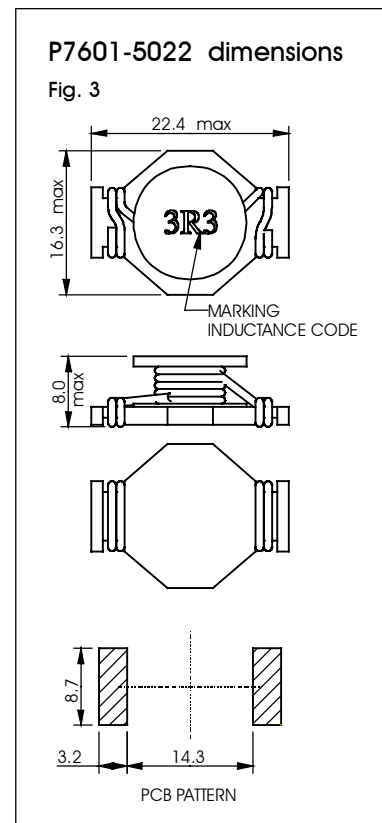
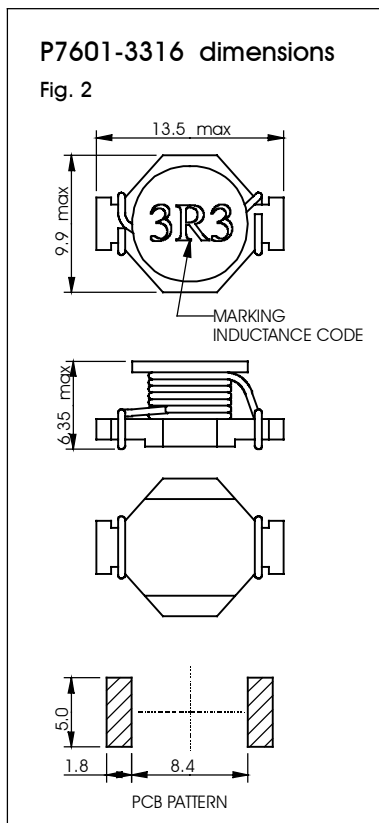
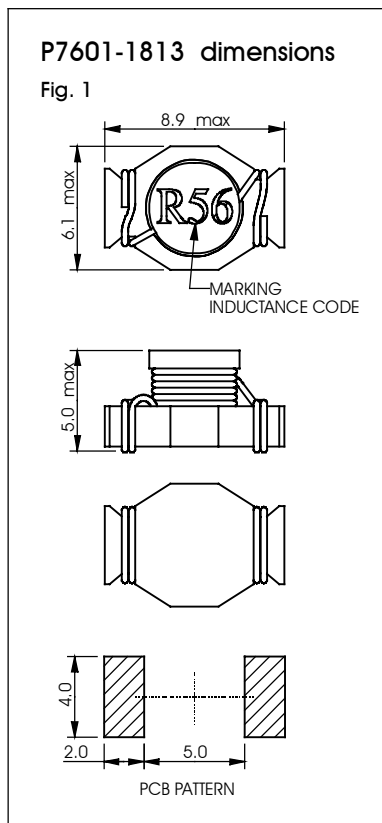

Dimensions shown are in millimetres

Terminal plating is pure tin (Sn).

Recommended reflow solder profile: 2 minutes (min) @ 100-150°C, 10 seconds (max) @ 230°C; time above 200°C 30 seconds maximum.

ORDERING CODE

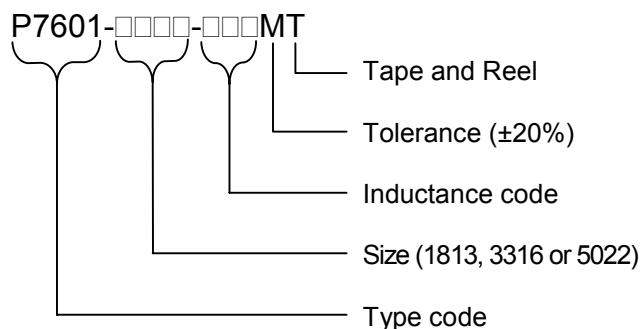

ABSOLUTE MAXIMUM RATINGS

Storage temperature	-40°C to +125°C
Operating temperature	-40°C to +85°C
Soldering temperature profile peak	260°C 10s

PROFEC
TRANSFORMING THE FUTURE



Profec Technologies Ltd., 10 Betts Avenue, Martlesham Heath, Ipswich, IP5 3RH, England

Telephone: +44 (0) 1473 611422

Fax: +44 (0) 1473 611919

Website: www.profec.com

Email: info@profec.co.uk, sales@profec.com