



APPROVED VENDOR SPECIFICATION



Vendor Name : MICRON ELECTRIC CO. LTD.

Catalog Name : N/A

Catalog Date / Revision : N/A

REMARK :

CHANGE : RELEASE DRAWING.

ISSUE : 01

ECO # :

PREPARED BY : Nancy Chen

CHECK :

APPROVED :

DATE : 2/28/2007

DATE :

DATE :

APPROVED VENDOR SPECIFICATION



Part Number	Description	Vendor Part Number	First Used On
24986600000	RES-WW XXX X XXX MSS07N200K	MSS07N SERIES	AA24800L

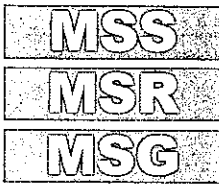

セメント抵抗器の基本型でマルチタイプ
Multi-type, basic for cement resistors

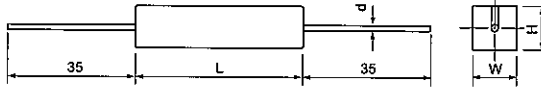

(MSS標準規格 EIAJ RC-2649) (MSS Standard Spec. EIAJ RC-2649)
UL File No. E 56291

定格電力 Rated power (W)	寸法 (mm) Dimensions (mm)				抵抗値範囲 (Ω) Resistance range					重量 Weight (g)
	L	W	H	d ± 0.1	MSS		MSR		MSG 標準品 Standard	
					標準品 Standard	U L 品 UL	標準品 Standard	U L 品 UL		
2	17.5 ± 1.2	6.4 ± 1	6.4 ± 1	0.80	0.15 ~ 200	0.15 ~ 200	100 ~ 20K	22 ~ 13K	0.15 ~ 200	2.1
3	22 ± 1.5	8.0 ± 1	8.0 ± 1	0.80	0.24 ~ 360	0.25 ~ 350	100 ~ 39K	33 ~ 22K	0.24 ~ 360	3.8
5	22 ± 1.5	9.5 ± 1	9.0 ± 1	0.80	0.3 ~ 510	0.3 ~ 500	100 ~ 51K	33 ~ 27K	0.3 ~ 510	5.1
7	35 ± 1.5	9.5 ± 1	9.0 ± 1	0.80	0.51 ~ 1.5K	0.5 ~ 1.4K	200 ~ 100K	5.6K ~ 56K	0.51 ~ 1.5K	7.7
10	48 ± 1.5	9.5 ± 1	9.0 ± 1	0.80	1.0 ~ 2K	1.0 ~ 2K	200 ~ 150K	5.6K ~ 75K	—	10.8
15	48 ± 1.5	12.5 ± 1.2	12.5 ± 1.2	1.00	1.0 ~ 2K	1.0 ~ 2K	510 ~ 200K	150 ~ 110K	—	18.3
20	63.5 ± 2.0	12.5 ± 1.2	12.5 ± 1.2	1.00	1.0 ~ 3K	1.0 ~ 3K	510 ~ 240K	10K ~ 180K	—	22.4

●軽減曲線 Derating curve

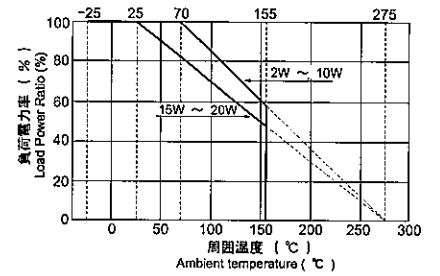

●温度上昇 (参考) Temperature rise (ref.)

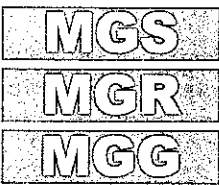
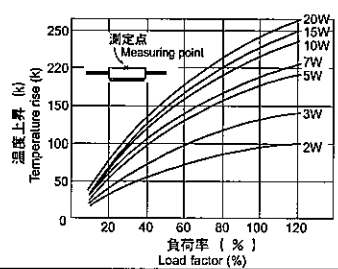

PCB への熱伝導を軽減するタイプ
Types for reducing heat conduction to PCB

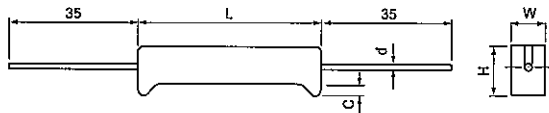

UL File No. E 56291

定格電力 Rated power (W)	寸法 (mm) Dimensions (mm)					抵抗値範囲 (Ω) Resistance range					重量 Weight (g)
	L	W	H	C	d ± 0.1	MGS		MGR		MGG 標準品 Standard	
						標準品 Standard	U L 品 UL	標準品 Standard	U L 品 UL		
2	17.5 ± 1.2	6.4 ± 1	7.9 ± 1	1.5	0.80	0.15 ~ 200	0.15 ~ 200	100 ~ 20K	22 ~ 13K	0.15 ~ 200	2.3
3	22 ± 1.5	8.0 ± 1	9.3 ± 1	1.5	0.80	0.24 ~ 360	0.25 ~ 350	100 ~ 39K	33 ~ 22K	0.24 ~ 360	3.9
5	22 ± 1.5	9.5 ± 1	11.0 ± 1	1.5	0.80	0.3 ~ 510	0.3 ~ 500	100 ~ 51K	33 ~ 27K	0.3 ~ 510	5.4
7	35 ± 1.5	9.5 ± 1	12.5 ± 1.2	3	0.80	0.51 ~ 1.5K	0.5 ~ 1.4K	200 ~ 100K	5.6K ~ 56K	0.51 ~ 1.5K	8.2
10	48 ± 1.5	9.5 ± 1	12.5 ± 1.2	3	0.80	1.0 ~ 2K	1.0 ~ 2K	200 ~ 150K	5.6K ~ 75K	—	11.0

●軽減曲線 Derating curve

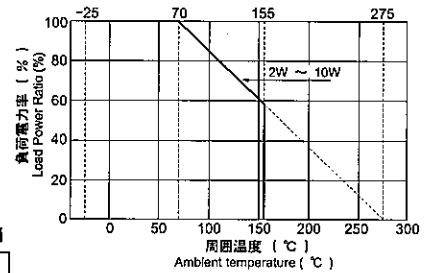

●温度上昇 (参考) Temperature rise (ref.)

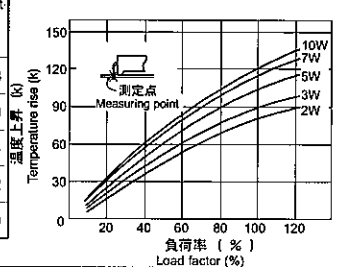

PCB 直接マウント、高負荷タイプ
PCB direct-mounting high-load types

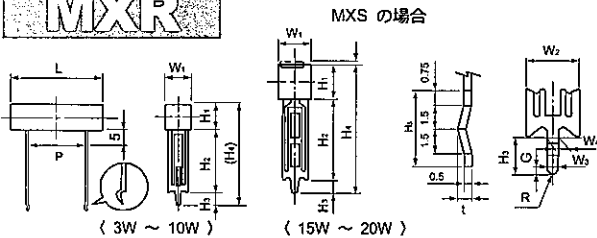

●軽減曲線

Derating curve

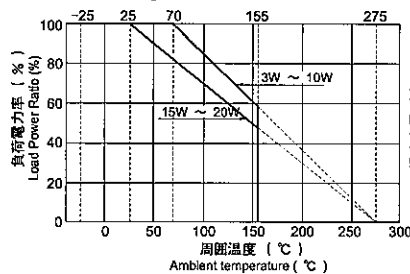

●温度上昇 (参考)

Temperature rise (ref.)

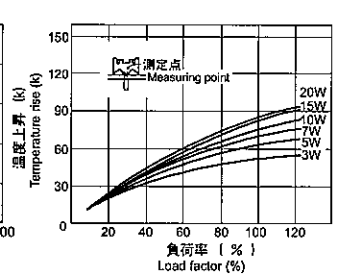

定格電力 Rated power (W)	寸法 (mm) Dimensions (mm)								抵抗値範囲 (Ω) Resistance range					重量 Weight (g)	
	L ₁	P	W ₁	W ₂	W ₃	W ₄	G	H ₁	H ₂	H ₃	H ₄	t	MXS		MXR
3	24 ± 1.2	12.5 ± 1	9 ± 1	7	1.4 ± 0.1	1.6 ± 0.1	0.7	9 ± 1	25 ⁺² ₋₁	4.5	38.5	0.85 ± 0.1	0.22 ~ 390	100 ~ 39K	6
5	27 ± 1.5	15 ± 1	9.5 ± 1	7	1.4 ± 0.1	1.6 ± 0.1	0.7	9.5 ± 1	25 ⁺² ₋₁	4.5	39	0.85 ± 0.1	0.47 ~ 680	100 ~ 51K	7.2
7	35 ± 1.5	22.5 ± 1	9.5 ± 1	7	1.4 ± 0.1	1.6 ± 0.1	0.7	9.5 ± 1	25 ⁺² ₋₁	4.5	39	0.85 ± 0.1	0.68 ~ 1.0K	200 ~ 100K	9
10	48 ± 1.5	35 ± 1	9.5 ± 1	7	1.4 ± 0.1	1.6 ± 0.1	0.7	9.5 ± 1	25 ⁺² ₋₁	4.5	39	0.85 ± 0.1	1.0 ~ 1.5K	200 ~ 150K	11.5
15	48 ± 1.5	32.5 ± 1	12.5 ± 1.2	10	2.7 ± 0.1	3 ± 0.1	1.35	12.5 ± 1.2	30 ± 2	5	47.5	1.1 ± 0.1	1.0 ~ 2.0K	—	18.2
20	63.5 ± 2	50 ± 1.5	12.5 ± 1.2	10	2.7 ± 0.1	3 ± 0.1	1.35	12.5 ± 1.2	30 ± 2	5	47.5	1.1 ± 0.1	1.0 ~ 3.0K	—	23.9

※ MXR は 1.14 ± 0.1

MXR の場合

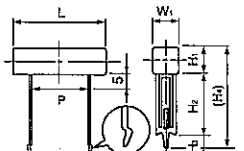

(3W ~ 10W)

MICRON -STANDARD SPECIFICATION		NO.	MDS P 5008 Rev. (3)
		WRITTEN ON	JUN. 21, 1982
TITLE	PRODUCT SPECIFICATION	EFFTV ON	JUN. 21, 1982
APPLICATION	WIRE-WOUND CEMENT RESISTOR	APPVD BY	PREPRD BY
		M.OGURA	S.KUMETA

1. GENERAL

1.1 Applicable Scope

This standard specifies the requirements for Wire-Wound Cement resistors (hereinafter called "resistors") manufactured by Micron.

1.2 Meanings of Terms

The meanings of the terms used in this standard are in accordance with JIS C 5201.

1.3 Part Number

To be composed as per the example below.

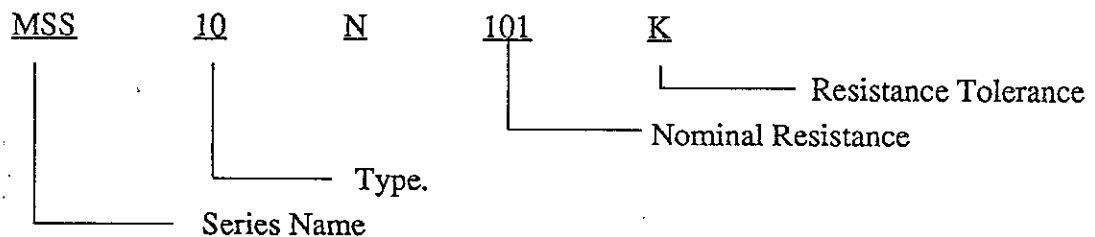

1.3.1 Series Name

"MSS" is the series name for this type of resistor.

1.3.2 Type

The Type is shown using one digit representing the rated power as shown in Table 1.

1.3.3 Nominal Resistance

Nominal resistance is shown using 3 digits, the first two of which are significant digits, and the last shows the number of zeros(0) to follow. A decimal point is indicated by the letter "R".

1.3.4 Resistance Tolerance

Resistance tolerance is indicated by a capital letter as per Table 1 as a general rule. Further details shall be specified in an individual drawing.

Further details shall be specified in an individual drawing.

Table 1 Resistance Tolerance

TYPE	Rated Power	Nominal Resistance Range	Resistance Tolerance	
			Mark	Tolerance
2	2W	0.15 Ω - 200 Ω	J	±5%
3	3W	0.24 Ω - 360 Ω	K	±10%
5	5W	0.3 Ω - 510 Ω		
7	7W	0.51 Ω - 1500 Ω		
10	10W	1 Ω - 2000 Ω		
15	15W	1 Ω - 2000 Ω		
20	20W	1 Ω - 3000 Ω		

1.4 Rating

1.4.1 Rated Power

The Rated Power is the value specified at a Rated Ambient Temperature of 70 °C for types 2,5,7and10, and at 25 °C for types 15 and 20.

The load power at an ambient temperature other than the rated ambient temperature shall be the maximum value resulting from, maximum multiplying the rated power by the load power derating ratio as specified by the derating curve in Fig. 1.

Fig.1 Load Power Derating Curve

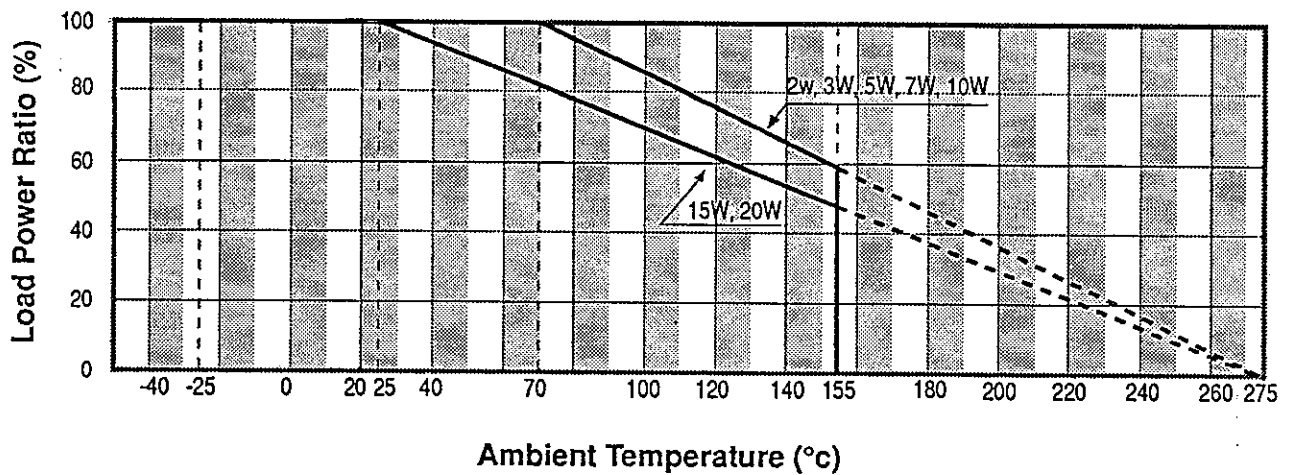

1.4.2 Rated Voltage

The Rated voltage is AC voltage (effective value of commercial frequency), or the DC voltage corresponding to the rated power, and shall be calculated using the following formula:

$$E = \sqrt{P \cdot R}$$

where E : Rated Voltage (V)
 P : Rated power (W)
 R : Nominal resistance (Ω).

1.5 Standard Test conditions

All measurements and tests in this standard shall be conducted, unless otherwise specified, in accordance with the JIS C 5020 3.1 standard conditions (5-35 °C, 45-85%).

In case of any discrepancies, or in case reproducibility is required, they shall be conducted in accordance with JIS C 5020 3.3 (20±2 °C, 65±5%).

2. STRUCTURE**2.1 External Shape & Dimensions**

External shape and dimensions shall be as specified in an individual drawing on the basis of APPENDED CHART 1.

2.2 Terminals

The Terminals shall be securely connected to the resistance element both electrically and mechanically. Terminal leads shall be as per JIS C 3102 or equivalent, being treated to allow easy soldering.

2.3 Armour

Armour shall be solid enough to protect against breakage, cracking, and looseness.

2.4 Markings

Markings shall applied to the resistor's surface, using a permanent media to show rated power, nominal resistance, resistance tolerance, short form of manufacturer's name (MICRON), and Manufactured Date Code (Year & Month) per EIAJ-RC-1001. Marking locations are shown by example in APPENDED CHART 1.

3. MECHANICAL PERFORMANCE

3.1 Terminal Strength

Under each of the following tests, terminal leads should not break or become loose, and the resistor body should not break. One sample may be used for all the tests described in paragraphs 3.1.1 and 3.1.2, but in this case the tensile strength shall be tested first.

3.1.1 Tensile Strength

Fixing the terminal leads so as to keep their normal axes perpendicular, a static load of 4.5kg. shall be gradually applied to one of the terminal leads, and retained for not less than 30 seconds.

3.1.2 Bending Strength

Holding the resistor so as to keep the normal axes of its terminal leads perpendicular, a load of 0.5 kg. shall be applied to the end of one terminal lead. The resistor body shall then be bent upto an angle of 90° (horizontally) and returned back to its original position. The same shall be done in the opposite direction. Both bends shall be conducted at about 10 seconds/cycle.

3.1.3 Torsional Strength

The terminal leads shall be bent at an angle of 90° at a point about 6mm from the resistor body with a radius of curvature of about 0.8mm. Securing the resistor body and holding the lead at a point $1.2^{+0.4}$ mm from the bend the lead shall be twisted 360° around on the normal axis. It shall then be twisted back 360° in the opposite direction as the 2nd turn, and thus repeated upto 5th turn, at the velocity of about 5 seconds per turn.

3.2 Vibration Test

The resistor, being fixed on a vibration-stand showed in Fig. 2, shall be subjected to vibration as per JIS C 5025 Test Method I, Class A. Resistance change thereafter shall be within $\pm(1\% \pm 0.05\Omega)$ of the initial value before the test, and there shall be no evidence of mechanical damage on any part of the resistor.

In cases of 10W, 15W, and 20W, resistor should be fixed with metal parts. Terminal line should be fixed also.

Figure 2 Resistors fitting method in vibration test

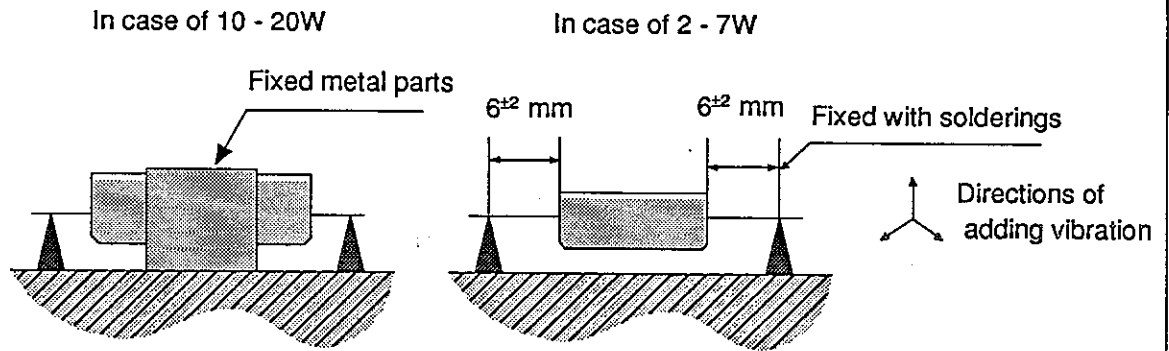

3.3 Soldering

Terminal leads with 4 ± 1 mm from the resistor are first dipped in 25% rosin methanol liquid and then dipped into molten solder at $230 \pm 5^\circ\text{C}$ for 5 ± 0.5 seconds and taken out. 90% or more of the lead should be immersed into solder.

3.4 Resistor to soldering Heat

The terminal leads with 4 ± 0.8 mm from the resistor shall be dipped into molten solder at $270 \pm 30^\circ\text{C}$ for 3 ± 0.5 seconds, and then returned to normal conditions for about 2 hours. Resistance change thereafter shall be within $\pm(2\% \pm 0.05\Omega)$ of the initial value before the test, and there shall be no evidence of mechanical damage on any part of the resistor.

3.5 Resistor Body Strength

Resistor body, being sustained at two positions each 3mm apart from each end of it, shall withstand a static load of 5kg. for 2W or 3W type, and 10kg. for 5W type, applied on its center with about 10mm contact in width.

4. ELECTRICAL PERFORMANCE

4.1 Resistance

Tolerance of resistance against the nominal value shall be as per Table 1, under normal conditions. Measuring shall be conducted using a bridge method, and the accuracy of the measurement must be better than the specified tolerance. The measuring voltage applied to the resistor shall be, in principle, as specified in Table 2, which may also be the power source voltage for the Bridge. The voltage application time shall be as short as possible and shall not exceed 5 seconds in any case.

Table 2 Maximum Measuring Voltage

Nominal Resistance Range (Ω)	less than 1	1 to less than 10	10 to less than 100	100 to less than 1k	1k or over
Maximum Applied voltage (V)	0.1 V	0.3 V	1 V	3 V	10 V

4.2 High Voltage test

When AC (commercial frequency) 1,000V (effective value) is to applied for one minute between metal foil wound around the center of the resistor (about 10mm wide) and the both terminals, no extraordinary conditions, such as arcing, should occur and the resistance change after removing the voltage should be within $\pm(0.5\% + 0.05\Omega)$ of the initial value before the test.

4.3 Insulation Resistance

Insulation resistance, measured using a 500V Megger, between both ends as per paragraph 4.2 shall not be less than 20M Ω .

4.4 Short-term Overload Characteristic

When a voltage equivalent to 10 times the rated power is applied to the resistor for 5 seconds continuously, there shall be no evidence of arcing, flames, etc. After it has been left at the original conditions for about 2 hours after removal of the voltage, the resistance change from the initial resistance before applying the voltage shall be within $\pm(2\% + 0.05 \Omega)$.

4.5 Resistance Temperature Characteristic

The resistor shall be subjected to each temperature step shown in Table 3, in the order specified, for not less than 30 minutes at each step. At the end of step, the resistance shall be measured, and the resistance temperature coefficient calculated using the following formula shall be within ± 400 PPM/deg.

Resistance Temperature Coefficient (PPM/deg.)

$$= \frac{R - R_0}{R_0} \times \frac{1}{t - t_0} \times 10^6$$

where t_0 : actual value of reference temperature ($^{\circ}\text{C}$)
 t : actual value of test temperature ($^{\circ}\text{C}$)
 R_0 : actual resistance at " t_0 " (Ω)
 R : actual resistance at " t " (Ω)

Table 3 Ambient temperatures used for calculation of resistance temperature coefficient

Step	Test Temperature ($^{\circ}\text{C}$)	
1	$20 \pm 3^{(1)}$	or, normal temperature
2	25 ± 3	
3	$20 \pm 3^{(1)}$	or, normal temperature
4	155 ± 3	

Notes: (1) This shall be used as the reference temperature against the lower (higher) test temperature to follow it.

5. WEATHER-PROOFING

5.1 Moisture Load Life Characteristic

Resistance under normal conditions shall be measured first. Then, with the resistors of about 25mm length, arrayed so as not to be influenced by one another's temperature, they shall be connected to a light-weight terminal, and shall be placed in a constant humidity/temperature oven at a temperature of 40^{+2} °C and a humidity of 90-95%. Under these conditions, a DC current equivalent to 1/10 of the rated power shall be applied between the resistor's leads for 1-1/2 hours, then cut off for 1/2 hour. This cycle shall be repeated for a total of 1000^{+48} hours (including cut-off time). Then, after removing the voltage, the resistors shall be taken out of the oven and left at normal conditions for about 2 hours. The resistance change thereafter shall be within $\pm(3\%+0.05\Omega)$ of the initial value before the test. There shall be no evidence of remarkable change in appearance, and the markings must still be legible.

5.2 Moisture Resistance

DC 100V shall be applied between both ends as described in paragraph 4.2 in the oven (per paragraph 5.1) for 1000^{+48} hours (connecting (-) polarity to the metal foil, and (+) to the other side). The resistor shall then be taken out of the oven, and the metal foil removed. Then, after not less than 30 minutes but within 1 hour after clearing away any waterdrops, the resistance and the insulation resistance (see paragraph 4.3) shall be measured. The resistance change from the initial value before the test shall be within $\pm(3\%+0.05\Omega)$, and the insulation resistance shall not be less than $5M\Omega$.

5.3 Load Life Characteristic

Resistance under normal conditions shall be measured first. The 25mm length resistors, connected to light-weight terminals, shall be kept level and arrayed so as not to be influenced by one another's temperature. Then, after being placed in the oven at the rated ambient temperature free from excessive ventilation the resistors, shall be subjected to a cycle of 1-1/2 hours ON, 1/2 hour OFF of the rated voltage between the terminals for a total of 1000^{+48} hours (including OFF time). After removing the current, the resistors shall be taken out of the oven and left under normal conditions for about 2 hours. Thereafter, the resistance change from the initial value before the test shall be within $\pm(5\%+0.05\Omega)$.

5.4 Heat Resistance

Placing the resistor in a constant temperature oven, the temperature shall be raised to 275^{+3} °C within 45 minutes, and kept there for 2 hours. Then it shall be gradually lowered down to room temperature. There shall be no evidence of damage to the resistor during the test.

5.5 Thermal Shock

Placing the resistor on an adiabatic board, within 8-12 seconds after applying the rated voltage for 30 minutes, it shall be placed into air at -25 ± 3 °C and left for not less than 15 minutes. Then it shall be returned to normal (original) conditions and left for about 2 hours. The change in resistance measured thereafter shall be within $\pm(2\%+0.05\Omega)$ of the initial value before the test, and there shall be no abnormal breakage, exfoliation, etc. of the protective coating.

6. OTHERS

- (1) Particulars other than described in this standard shall be specified upon deliberation.
- (2) Individual drawing and specification approved shall govern this standard.

APPENDED 2 External dimensions

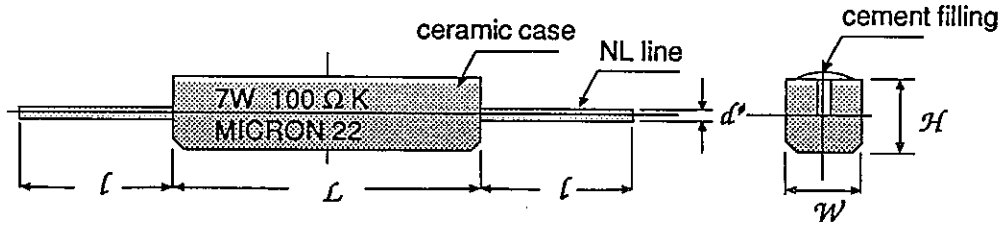

APPENDED CHART 1 Dimensions & Resistance Range

Type	Rated Power	Dimension mm				
		L	W	H	l	d
2	2W	17.5±1.2	6.4±1	6.4±1	35±3	0.8±0.1
5	5W	22±1.5	9.5±1	9±1	35±3	0.8±0.1
7	7W	35±1.5	9.5±1	9±1	35±3	0.8±0.1
10	10W	48±1.5	9.5±1	9±1	35±3	0.8±0.1
15	15W	48±1.5	12.5±1.2	12.5±1.2	35±3	1±0.1
20	20W	63.5±2	12.5±1.2	12.5±1.2	35±3	1±0.1

Reference Data Temperature Rise Corresponding to Load Power

