



DR-GPS module Specification

Trimble Part Number: 778888-20

Trimble Project Name Numbat

Copyright ©

Trimble Navigation Limited
935 Stewart Drive, SUNNYVALE,
CA 94085 USA

All rights reserved

Trimble Proprietary & Confidential

REVISION HISTORY

No.	Date	Issued by	Description
1	07-April-2015	Jackson Yoon	Initial

TABLE OF CONTENTS

1	INTRODUCTION	5
1.1	PROPOSE	5
1.2	SCOPE	5
1.3	SYSTEM OVERVIEW	5
2	GPS	6
2.1	ASSUMPTION	6
2.2	DYNAMIC LIMITS	6
2.3	COCOM LIMITS	6
2.4	FIX RATE	6
2.5	GPS ACCURACY	7
2.6	TIME TO FIRST 2D FIX / GPS ACQUISITION RATE	7
2.7	SENSITIVITY	7
3	ELECTRICAL SPECIFICATIONS	8
3.1	NORMAL OPERATING CONDITIONS	8
3.2	RF	8
3.3	DATA I/O	9
3.4	PPS	9
3.5	POWER REQUIREMENT	9
3.6	GPS ANTENNA CHARACTERISTIC	10
4	SOFTWARE	11
4.1	CAPABILITIES	11
4.2	PERFORMANCE	16
4.3	UPGRADABILITY	16
4.4	COMMUNICATION PROTOCOL	17
4.5	PORT CONFIGURATION	17
5	MECHANICAL SPECIFICATIONS	18
5.1	FORM FACTOR	18
5.2	PIN-OUT ASSIGNMENT	18
5.3	DETAILED PIN DESCRIPTION	20
5.4	MECHANICAL DRAWING	22
6	ENVIRONMENTAL SPECIFICATIONS	23
7	GENERAL RECOMMENDATION	24
7.1	SUGGESTED CUSTOMER SOLDER MASK	25
7.2	SUGGESTED CUSTOMER PAD PATTERN	26
7.3	SUGGESTED CUSTOMER PASTE PATTERN	27
7.4	CO-PLANARITY	27
7.5	ANTENNA OPEN/SHORT DETECTION AND PROTECTION	28
8	HANDLING	29
8.1	MOISTURE PRECONDITION	29
8.2	BAKING PROCEDURE	29
8.3	SOLDERING PASTE	29
8.4	SOLDER REFLOW	30
8.5	RECOMMENDED SOLDER PROFILE	30
8.6	OPTICAL INSPECTION	31
8.7	CLEANING	31
8.8	REPEATED WAVE SOLDERING	31

8.9	WAVE SOLDERING	31
8.10	HAND SOLDERING	31
8.11	REWORK.....	31
8.12	CONFORMAL COATING	31
8.13	METAL SHIELD GROUNDING.....	32

1 INTRODUCTION

1.1 Propose

This document specifies the hardware and software characteristics of the DR-GPS module, a 19x19 mm SMT-sized Dead Reckoning (DR) Host Independent Positioning GPS receiver.

1.2 Scope

This document defines the specification for a 19mm x 19mm SMT sized Dead Reckoning (DR) Host Independent Positioning module. The objective of this document is to establish the electrical, mechanical, environmental and functional specifications to be achieved by the DR-GPS module.

1.3 System Overview

The DR-GPS module is a module containing a microprocessor along with an embedded GPS receiver chip. The DR-GPS module board requires 3.3 ± 0.3 Volts and operates with an active GPS antenna. Depending on the implemented circuit, power-feeding to GPS Antenna can be 3.0V or 5V.

2 GPS

2.1 Assumption

The module will provide the same GPS core performance.

All performance, accuracy, acquisition and availability requirements assume the following conditions, unless otherwise specified:

- Clear view of the sky.
- Multipath-free environment
- ≥ 5 Satellites in view
- > 36 CNO signal strengths
- Stable temperature (< 3 deg C change per minute)
- < 6 PDOP
- Position change < 800 km since last power down.

2.2 Dynamic Limits

Characteristic	Limits
Altitude	-1000 to +18000 m MSL
Velocity	515 m/s
Acceleration	$4g^1$
Motion Jerk	20 m/sec^3

Note: The dynamics limits listed here are not intended as COCOM limits; they are specified below.

2.3 COCOM Limits

In compliance to the COCOM limits set by the US government, the device will not operate when velocity exceeds 600 m/sec.

COCOM
The unit will cease to output position, velocity, time, Doppler range, pseudo ranges, and 1PPS when the velocity condition is violated (515m/s title 22 part 121 sectional category XV)

The device will operate with reduced accuracy when the acceleration exceeds 1g.

2.4 FIX Rate

Item	Rate
DR Fix Rate	5 Hz (Default) with 10Hz Option
GPS Fix Rate	1 Hz

2.5 GPS Accuracy

The entries in this table all assume that the unit is producing valid position fixes. The accuracy is specified for 3D, or 2D with a reference altitude. Clear view autonomous GPS conditions (outdoor). Velocity accuracies are steady state.

Parameter	CEP 50%	CEP 90%
Position, Horizontal	2.0. m(S-BAS On)	3.0 m(S-BAS On)
	3.0 m(S-BAS Off)	5.0 m(S-BAS Off)
Position, Vertical	< 5 m	< 8 m
Speed Accuracy	n/a	0.06 m/s
Heading Accuracy	(0.05 m/s)/Speed (1 σ)	

2.6 Time to First 2D Fix / GPS Acquisition Rate

GPS acquisition time is defined as the time from prime power on to the output of valid position fixes. Under the following conditions, time to first fix (TTFF) can be affected:

- Satellite visibility (fewer than 5 SVs in view with CNR greater than 40);
- Temperature drift (> 2C per minute);
- GPS receiver has been powered down for more than one hour (which affects the validity of satellite ephemeris data);
- Backup power was not applied during power-down.

The acquisition times listed in the table below will be valid when the unit is at room temperature, has a clear view of the sky with a minimum of 5 SVs in view, and has not been moved more than 800 km since the last position fix.

Type	Conditions	Acquisition Rate
Cold start	No almanac, no ephemeris, no position, no time from RTC. No backup power available	≤ 45 s (50%)
Warm start	Current almanac, position and time available. Backup power is available.	≤ 38 s (50%)
Hot start	Current almanac, ephemeris and position available. Backup power is available.	≤ 12 s (50%)
Reacquisition	For blockages of GPS signal <15 s. Back up power is available.	≤ 3 s

2.7 Sensitivity

Item	Rate
Acquisition	-146dBm
Tracking	-160dBm

3 ELECTRICAL SPECIFICATIONS

All specifications are over the entire temperature range, -40°C to +85°C.

3.1 Normal Operating Conditions

Parameter	Min	Typ	Max	Units	Conditions
Supply voltage	3.0	3.3	3.6	VDC	
Power consumption	210	220	250	mW	Exc. antenna
Supply voltage noise ripple			50	mVpp	from 1Hz to 1MHz
Input capacitance on power supply		22		μF	
Supplied current for Low Noise Amplifier of active antenna			30	mA	3.0V Miniature GPS Vehicle Ant. (at room temperature)
Backup Power Supply	2.5		3.6	VDC	
Backup Current	8	10	25	uA	Over temp. range -40, +85 °C

3.2 RF

Parameter	Min	Typ	Max	Units	Conditions
Tracking sensitivity	30			dB	C/No - ratio of GPS signal power to noise power in a 1 Hz bandwidth at the RF connector input of the receiver
Noise Figure		3		dB	
Resistance to broadband noise jamming			20	dB	jamming to signal ratio at antenna input within input filter bandwidth of 20MHz; GPS Signal Power ≥ -160dBW
Input impedance		50		Ω	

3.3 DATA I/O

The device will support the following characteristics:

- CMOS/TTL levels on TXD and RXD
- Fixed UART baud rates

Parameter	Min	Typ	Max	Units	Conditions
Data rate		38.4	115.2	kbps	+/- 3% error rate
Input voltage			0.8	V	low level at 50 uA
	2.0				high level at 50 uA
Output voltage			0.4	V	low level at 4 mA at Supply Voltage
	2.4				high level at 4 mA at Supply Voltage
Input current	-50		50	μA	low level
	-50		50		high level
Data latency after PPS			100	ms	Delta between PPS and packet transmission

3.4 PPS

The PPS will be present once power is applied to the unit.

Parameter	Min	Typ	Max	Units	Conditions
Timing accuracy			±500	ns	To UTC time with valid position fixes
Pulse duration	4	4	10	us	
Rise time of leading edge			25	ns	Rising edge is synchronized to UTC second.
Output voltage			0.4	V	low level (3.3V)
	2.4				high level (3.3V)

3.5 Power requirement

VCC rising time should be below 5 ms and other leakage volatges(currents) should not be applied to the DR-GPS module in advance against VCC.

3.6 GPS Antenna Characteristic

Antenna compatibility: active

Power(3.0V) will be provided to the antenna through the center conductor of the RF connector.

Parameter	Min	Typ	Max	Units	Conditions
LNA Gain		25		dB	
Cable Loss			5	dB	
Noise Figure					
Resistance to broadband noise jamming			20	dB	Jammer to signal ratio at antenna input within input filter bandwidth of 20MHz; GPS Signal Power \geq -130dBm
Resistance to RF burnout			1	W	Signals > 100MHz from L1 @ 1m from the antenna

4 Software

4.1 Capabilities

Parameter	Description
DR reporting frequency	Provide DR positioning data at a programmable frequency between 1 and 10Hz.
DR position reporting	The following DR position data will be provided: <ul style="list-style-type: none"> • Position as WGS84 latitude $[-\pi/2 \text{ rad}, \pi/2 \text{ rad}]$, longitude $[-\pi, +\pi \text{ rad}]$ and altitude [m] • Position accuracy [m] • Position status (invalid, valid)
DR heading reporting	The heading is always the direction at which the front of the car is pointing to. (North is 0 radians, clockwise is positive increasing) The following DR heading information will be provided: <ul style="list-style-type: none"> • Heading $[0, 2\pi \text{ rad}]$ • Heading accuracy [rad] • Heading status (invalid, valid)
DR speed reporting	The following DR speed data will be provided: <ul style="list-style-type: none"> • Speed [m/s] • Speed accuracy approximation (derived from Kalman filter parameters) [m/s] • The direction switch status (invalid, forward, backward) • Speed status (invalid, valid) • Motion indicator (invalid, motion, no motion)
DR cumulative delta-altitude	The following DR delta-altitude will be provided: <ul style="list-style-type: none"> • Cumulative delta-Altitude[m] • Cumulative delta-Altitude accuracy • Cumulative delta-Altitude status (invalid, valid)
DR delta distance reporting	The following DR delta distance data will be provided: <ul style="list-style-type: none"> • Delta distance [m] since previous timestamp (not based on the distance between 2 successive positions) • Delta distance accuracy approximation (derived from Kalman filter parameters) [m] • Delta distance status (invalid, valid) • Will always be positive value. (Total distance forward – total distance backward) since last report. Direction status will indicate if direction traveled is forward or backward.

Parameter	Description
DR delta heading reporting	<p>The following DR delta heading data will be provided:</p> <ul style="list-style-type: none"> • Delta heading [centidegrees] since previous timestamp • Delta heading accuracy approximation (derived from Kalman filter parameters) [centidegrees] • Delta heading status (invalid, valid)
GPS reporting frequency	Provide GPS positioning data at a programmable frequency of 0 or 1 Hz.
GPS position reporting	<p>The following GPS position data will be provided:</p> <ul style="list-style-type: none"> • Position as WGS84 latitude $[-\pi/2 \text{ rad}, \pi/2 \text{ rad}]$, longitude $[-\pi, +\pi \text{ rad}]$ and altitude [m] • GPS status (no SVs, tracking but no position, 2D, 3D) • Position Accuracy (m)
GPS heading reporting	<p>The heading is always the direction that the front of the car is pointing. (North is 0 radians, clockwise is positive increasing).</p> <p>The following GPS heading data will be provided:</p> <ul style="list-style-type: none"> • Heading [0 rad, 2π rad] • Heading status (invalid, valid) • Heading accuracy (rad)
GPS speed reporting	<p>The following GPS speed data will be provided:</p> <ul style="list-style-type: none"> • Speed [m/s] • Speed status (invalid, valid) • Speed accuracy (m/s)
System information	<p>The following information will be provided on request and at power on:</p> <ul style="list-style-type: none"> • GPS Receiver connected/responding status • Battery Backup (error) status • Antenna feed line error (open/short) status • Almanac status • DR software version • DR software date • GPS software version • GPS software date • Flash data (product name, serial number, and date of manufacture) • Sensor status indication: tacho and gyro detected

Parameter	Description
GPS information	<p>The following GPS data will be provided:</p> <ul style="list-style-type: none"> • IDs of tracked satellites (#) • SNR's of tracked satellites (dB-Hz) • Number of visible (tracking list) satellites • Azimuth of each visible satellite (°) • Elevation of each visible satellite (°) • DOP values • UTC time (yyyy/mm/dd/hh/mm/ss) • GPS time • GPS status
Map matching	The device will be able to use map positions and heading, received via messages, to improve positioning data accuracy.
BGRAM	The device will keep positioning data, sensor calibration data and GPS almanac and ephemeris data during power off with backup power available. This includes “no tacho mode” indicator. The saved values will be used at restart of the system.
RTC	The RTC will be kept alive when backup power is present.
Self-calibration	<p>The un-calibrated device will be able to calibrate itself (e.g. provide valid positioning data) from the first GPS 2D measurement onward. The device will be fully calibrated when:</p> <ul style="list-style-type: none"> • GPS is navigating uninterrupted during 60 seconds (DPP) • Speed during these 60 seconds is > 8m/s (DPP) • Gyro sensitivity after 100 right hand turns (GSF) <p>Constraint: The device should be calibrated on horizontal roads. The position is valid after the first 3D position fix.</p>
Direction switch	The device will automatically determine the direction switch logic level.
Non-volatile memory (NVRAM)	The device will support a message to perform a back-up of DR calibration and user configuration data into flash/NVRAM.
Calibration data	The device will support messages to send and receive positioning and sensor calibration data that needs to be preserved during power loss.
Raw sensor diagnostics	<p>The device will provide the following raw sensor data with programmable update frequencies between 0Hz and 1Hz, upon request, and also upon request when value changes (HIPPO packet 30-02):</p> <ul style="list-style-type: none"> • Number of actual speed sensor pulses • Actual Direction Switch value • Average Gyro Voltage output • Average Accelerometer output • Δ time

Parameter	Description
Calibration data diagnostics	<p>The device will provide the following calibration data with programmable update frequencies between 0Hz and 1Hz, upon request, and also upon request when value changes (HIPPO packet 36-XX):</p> <ul style="list-style-type: none"> • Zero Rate Output (ZRO) • Sensitivity (mV/°/s) • Gyro Calibration Status (ZRO Calibrated Y/N, Sensitivity Calibrated Y/N) • Accelerometer Calibration Status(Calibrated Y/N) • Direction Switch status (Calibrated, Y/N) • Direction Switch value (Forward or Reverse) • Distance per pulse (DPP) • Speed sensor calibration status (Calibrated, Y/N)
Sensor interface test	<p>The device will provide the following self-test functions at Power On. The results of the test will be reported to the host upon query.</p> <ul style="list-style-type: none"> • ADC/Gyro: read voltage level on startup and verify its validity • Accelerometer : read Accelerometer output on startup and verify its validity
Power On self test	<p>The following diagnostic self-tests will be performed when device is initially powered on:</p> <ul style="list-style-type: none"> • FLASH ROM checksum • RTC validation • RAM Read/Write test
Run-time positioning diagnostics	<p>The device will have the capability to constantly verify the performance of the GPS against the peripheral DR inputs and vice versa during normal operation. If any instance of non-conformance is detected, the device will log the non-conformance event in an error log.</p> <p>The instances of non-conformance are as follows:</p> <ul style="list-style-type: none"> • A positioning process is not active under normal conditions. • Gyro readings do not stay within specification. • No tacho data is received during a period when GPS is detecting movement. • Excessive tacho data is received for a long period of time. • Reverse signal is opposite to the direction determined by GPS. When battery back up data is not available, the reverse signal must be calibrated before an error can be reported. • Large or numerous jumps occur as a result of differences between DR positions and GPS Positions. • Oscillator values are not within specification.

Parameter	Description
Error/event log	<p>The device will have an error/event log in non-volatile memory. It is defined in detail in the Trimble document. This log will record all system events and errors.</p> <p>All events reported to the log will have the following format:</p> <ul style="list-style-type: none"> • Event identification • Time tag (yymmddhhmmss) <p>Writing to the log will initiate an error message to the host using the HIPPO packet 14-01. The log will maintain the last 128 events that occur in the system. Any prior events will be lost.</p> <p>The log queue is maintained in non-volatile memory.</p> <p>Access to the log will be available via HIPPO 14-01.</p>
BBRAM backup	<p>The entire contents of the BBRAM will be saved to non-volatile memory when receiving a “graceful shutdown” HIPPO packet.</p>
TCXO aiding	<p>The value of the TCXO offset will be stored in non-volatile memory during production test. It will be used to improve GPS acquisition and tracking provided the GPS module supports accepting externally-provided TCXO offset.</p>

4.2 Performance

Parameter	Description
DR position accuracy	Overall position accuracy with GPS will be better than or equal to the GPS position accuracy. Position accuracy without GPS will be within the limits of the individual heading and speed accuracy as defined in this section.
DR heading accuracy	With use of a GYRO, the heading accuracy, when GPS is available, will be: <ul style="list-style-type: none"> • Within 2 degrees when speed > 1 m/s or speed = 0 m/s. • Within 10 degrees when: speed < 1 m/s and speed ≠ 0 m/s and within gyro-drift of the actual used gyro when GPS is not available (2 degrees + heading difference caused by gyro-drift). Without use of a GYRO (only in 'GPS only' applications and in non-calibrated positioning module), the heading accuracy will be better than or equal to GPS heading accuracy.
DR speed accuracy	With use of a speed sensor, the speed accuracy will be better than 0.2 m/s. at speeds above 0.5 m/s. Without use of a speed sensor (only in 'GPS only' applications and in non-calibrated positioning module), the speed accuracy will be better than or equal to the GPS speed accuracy. Motion is defined as "speed is above lowest detectable speed". Speeds above 0.5 m/s. should always have this motion indication).
DR delta distance accuracy	With use of a speed sensor, the delta distance accuracy will be better than 0.2 m/s. at speeds above 0.5 m/s. Without use of a speed sensor (only in 'GPS only' applications and in non-calibrated positioning module), the delta distance accuracy will be better than or equal to GPS speed accuracy.
DR delta heading accuracy	With use of a gyro, the delta heading accuracy will be better than 1 degree/s. Without the use of the gyro (only in non-calibrated positioning module), the delta heading accuracy will be better than or equal to the GPS delta heading accuracy.
DR Cumulative Delta-Altitude Accuracy	With use of a Accelerometer, the delta-altitude will be better than 1% per distance travelled.
GPS position accuracy	See Section 2.5
GPS speed accuracy	See Section 2.5
GPS heading accuracy	See Section 2.5

4.3 Upgradability

Parameter	Description
Application firmware	The application firmware will be upgradable in the field using the Trimble GPS Studio software program or by the user application implementing a firmware upgrade protocol.

4.4 Communication Protocol

Parameter	Description
HIPPO	The HIPPO protocol interface will be implemented. Refer to Trimble document for more details on the protocol.
NMEA	The NMEA protocol interface will be implemented. Only the standard NMEA output messages GGA, GSA, GSV, GLL, RMC, VTG, and ZDA will be supported. The protocol will be made selectable via an input HIPPO command.

Note: Both protocols will be generated through the serial port with a switch feature to switch off the auto-output of either the HIPPO or NMEA. NMEA output is not available right now.

4.5 Port Configuration

Port	Input	Setup	Output	Setup
Port 1	HIPPO	38400-8-NONE-1	HIPPO	38400-8-NONE-1

5 MECHANICAL SPECIFICATIONS

5.1 Form Factor

Parameter	Description
Size	The device size will be 19mm x 19mm x 2.54mm without RF connector.
Mounting	See mechanical drawing in the for SMT operation.
Metal Shield	A metal shield covers the entire module for handling, ESD protection and mechanical damage.

5.2 Pin-out Assignment

<i>GND</i>	1	Numbat	28	<i>GND</i>
<i>GND</i>	2		27	<i>Reserved</i>
<i>RF In</i>	3		26	<i>GPIO (Fwd / Rev)</i>
<i>GND</i>	4		25	<i>GPIO (tacho)</i>
<i>GPIO (Reserved)</i>	5		24	<i>UART TXD</i>
<i>V_{backup}</i>	6		23	<i>Reserved</i>
<i>GPIO (antenna open)</i>	7		22	<i>Reserved</i>
<i>GPIO (antenna short)</i>	8		21	<i>Reserved</i>
<i>Boot</i>	9		20	<i>UART RXD</i>
<i>GPIO (Reserved)</i>	10		19	<i>PPS</i>
<i>Xreset</i>	11		18	<i>Reserved</i>
<i>Reserved</i>	12		17	<i>Reserved</i>
<i>Reserved</i>	13		16	<i>Vcc</i>
<i>GYRO_GND</i>	14		15	<i>GND</i>

Note : UART Rx/Tx is for manufacturer.

Pin #	Description
1	Ground
2	Ground
3	RF_IN - The RF input is 50 Ohms unbalanced GPS RF input, and should be used with active antennas
4	Ground
5	Reserved
6	Vbackup Battery backup voltage 2.5V to 3.6V
7	GPIO (Antenna Open)
8	GPIO (Antenna Short)
9	Boot (Reserved) If customer 'd like to use this for F/W upgrading feature, it should be Active High to make Numbat to go into F/W upgrade mode during F/W upgrade period. Normal(LOW), Boot mode(HIGH)
10	GPIO
11	XRESET input pin for external reset, active low (0/3.3v)
12	Reserved
13	Reserved
14	Ground
15	Ground
16	VCC
17	Reserved
18	Reserved
19	1PPS output, Pulse per second.
20	UART RXD input. For external pull-up resistor, load 4.7kohm.
21	Reserved
22	Reserved
23	Reserved
24	UART TXD output. For external pull-up resistor, load 4.7kohm.
25	Tacho sensor input
26	FWD/REV direction switch input (0/3.3V)
27	Reserved
28	Ground

5.3 Detailed Pin Description

RFIN	The RF input pin is the 50ohm unbalanced GPS RF input, and can be used with active antennas.
OPEN /SHORT	<p>When the user uses an active antenna, Trimble recommends that you use an antenna detection circuit that has short-circuit protection. The pins are provided for reporting the antenna status: OPEN and SHORT. The SHORT pin usually functions as an input to monitor for short circuits. Following a short-circuit condition, it is driven high for approximately 25microseconds in every second to turn the antenna power circuit back on.</p> <p>The logic level inputs outlined in the following table can be used with a detection circuit(with or without protection) to monitor the status of the external LNA of an active antenna by the module. The input pins also confirm to the Input/Output Pin threshold levels specified in the truth table for the logic of these signals:</p> <p>Condition of logic signals</p> <p>Antenna Reports</p> <p>SHORT Pin</p> <p>OPEN Pin</p> <p>Antenna Open reported</p> <p>1</p> <p>1</p> <p>Antenna Normal reported</p> <p>1</p> <p>0</p> <p>Antenna Shorted reported</p> <p>0</p> <p>0</p> <p>Undefined</p> <p>0</p> <p>1</p> <p>¹ If the SHORT pin is not used, it should be pulled to Vcc through a 10Kohm resister.</p>

	<p>² If the OPEN pin is not used, it should be pulled down to GND through a 10Kohm resistor.</p> <p>A typical active antenna draws between 10mA to 20mA. The antenna's protect/detect circuit will short circuit at around 100mA. Trimble recommends that you keep the antenna current below 75mA. An open circuit is determined if the antenna current falls below approximately 2mA.</p>
RESET	Use this logic-level, active low input to issue a reset to the module. It can be connected to external logic or to a processor to issue a reset instruction. To reset the module, drive this pin to logic level "0" or "Low" for at least 100microseconds, and then either release this signal or drive it back high. This pin has an internal 10Kohm pull-up resistor – if this pin is not used, it should be left disconnected. For external pull-up resistor, if it is used, load 4.7kohm.
VCC	This is the primary voltage supply pin for the module
RXD	T For external pull-up resistor, load 4.7kohm.his logic level input is the serial port receive line (data input to the module).
TXD	This logic level output is the serial port transmit line (data output from the module). For external pull-up resistor, load 4.7kohm.
RESERVED	There are several reserved pins. DO NOT connect these pins.

5.4 Mechanical Drawing

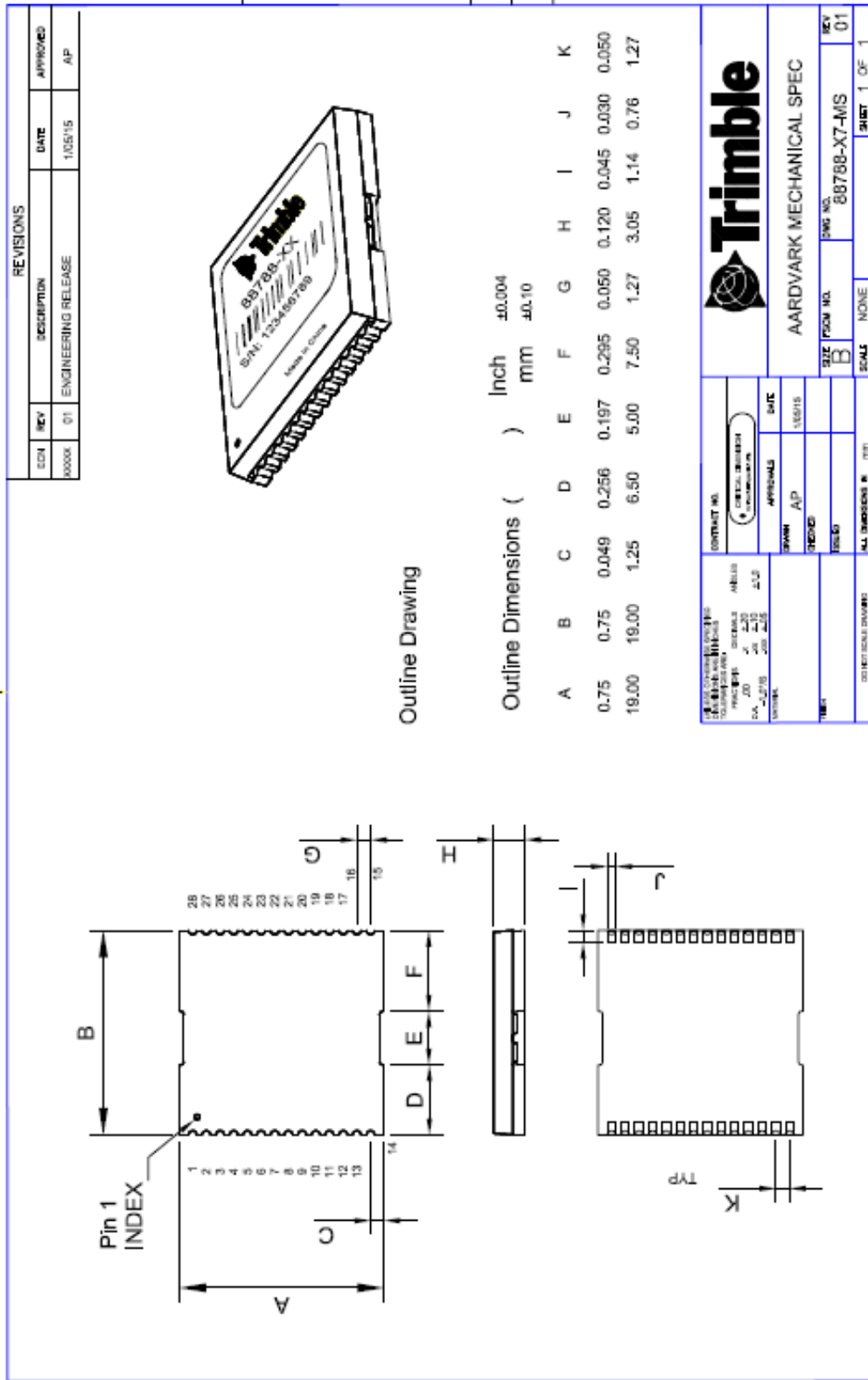

6 ENVIRONMENTAL SPECIFICATIONS

Parameter	Min	Typ	Max	Units	Conditions
Operating Temperature	-40		+85	°C	
Storage Temperature	-55		+105	°C	
Humidity	5		95	%	% R.H. non-condensing at +60 °C.
Thermal Shock	-55oC		+85oC		The unit will sustain proper operation after a temperature shock of -55oC to +85oC for 300 cycles.
Mechanical Shock (Non-Operational)			75Gs		The unit will sustain proper operation after a mechanical shock (drop) test of 75Gs 6 msecs
Mechanical Shock (Operational)			40Gs		The unit will sustain proper operation after a mechanical shock (drop) test of 40Gs 11 msecs
ESD	ESD testing was performed using the IEC1000-4-2 standard. All inputs and outputs are protected to ±500 volts ESD level. The RF IN pin is protected up to 1kV. If a higher level of compliance is required, additional electrostatic and surge protection must be added.				
Vibration	The device will maintain full performance specifications when the unit is subjected to vibration of up to (5Hz/0.02g ² /Hz., 20/0.05, 100/0.05, 800/0.001, 1000/0.001) 3.0 g rms, 15 min each of 3 axis.				

7 GENERAL RECOMMENDATION

The design of the RF transmission line that connects the GPS antenna to the DR-GPS module is critical to system performance. If the overall RF system is not implemented correctly, the DR-GPS module performance may be degraded.

The radio frequency (RF) input on DR-GPS module is a 50 ohm, unbalanced input. There are ground castellations, pins 2 and 4, on both sides of the RF input castellation, on pin 3. This RF input may be connected to the output of an LNA which has a GPS antenna at its input or to a passive antenna via a low-loss 50 ohm, unbalanced transmission line system.

Connections to either the LNA output must be made using a 50 ohm unbalanced transmission system. This transmission system may take any form, such as microstrip, coaxial, stripline or any 50 ohm characteristic impedance unbalanced, low-loss system. It is important to keep any noise sources with frequencies at or near 1575 MHz away from the RF input.

When an active antenna is used and it is desired to power this antenna from the RF transmission line, a bias-tee will be required at the DR-GPS module. A simple series inductor (that is parallel resonant at 1575 MHz) and shunt capacitor (series resonant at 1575 MHz) to which the bias voltage is supplied is sufficient. An open/short detection and over current protection circuit may also be employed. Please see Part 8.

In the printed circuit board(PCB) layout, Trimble recommends that user keep the copper layer on which the DR-GPS module is mounted clear of solder mask and copper(vias or traces) under the module. This is to insure mating of the castellations between the DR-GPS module and the board to which it is mounted, and that there is no interference with feature beneath the DR-GPS module that will cause it to lift during the re-flow solder process.

7.1 Suggested Customer Solder Mask

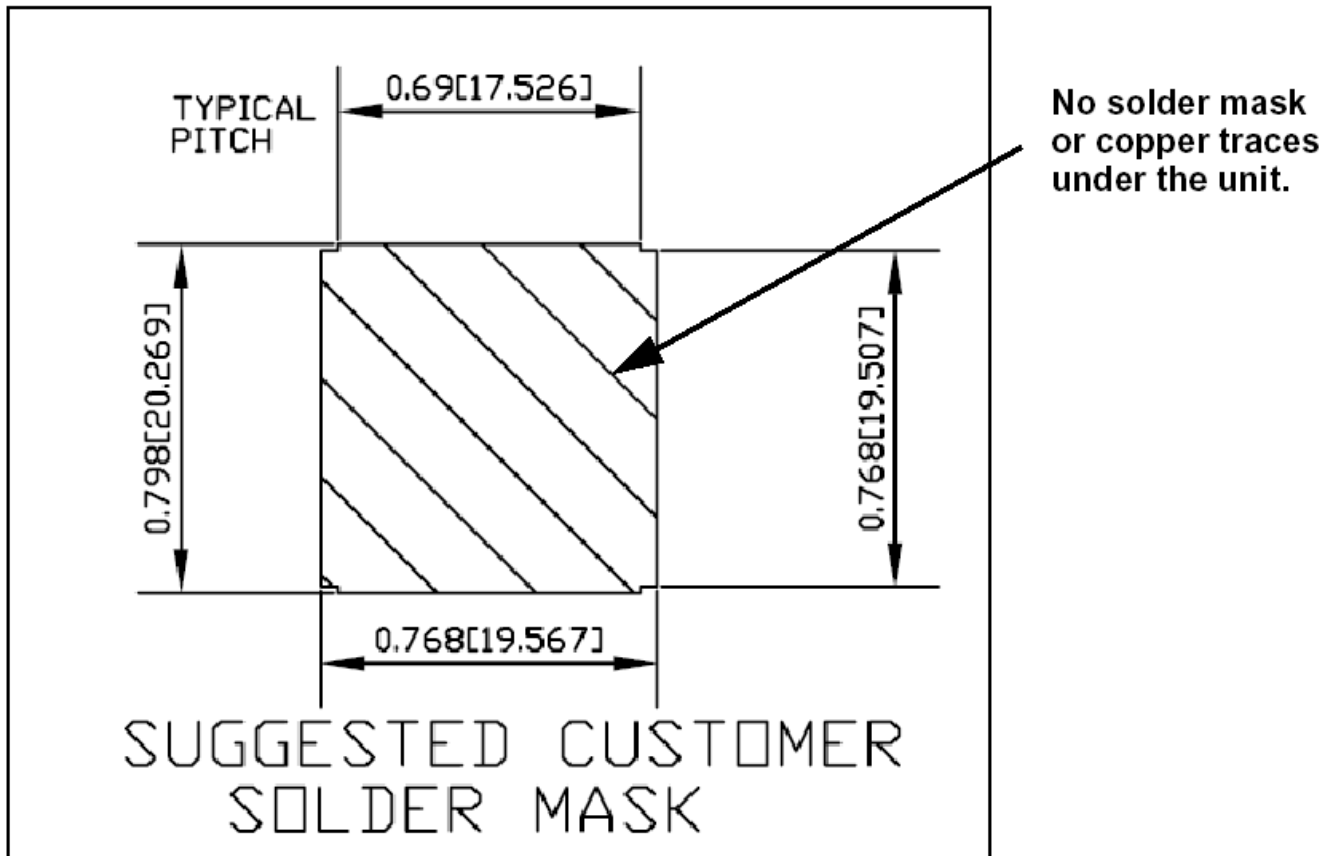

<DR-GPS module Solder Mask>

Note: No solder mask or copper traces or vias or conductive elements under the unit

7.2 Suggested Customer Pad Pattern

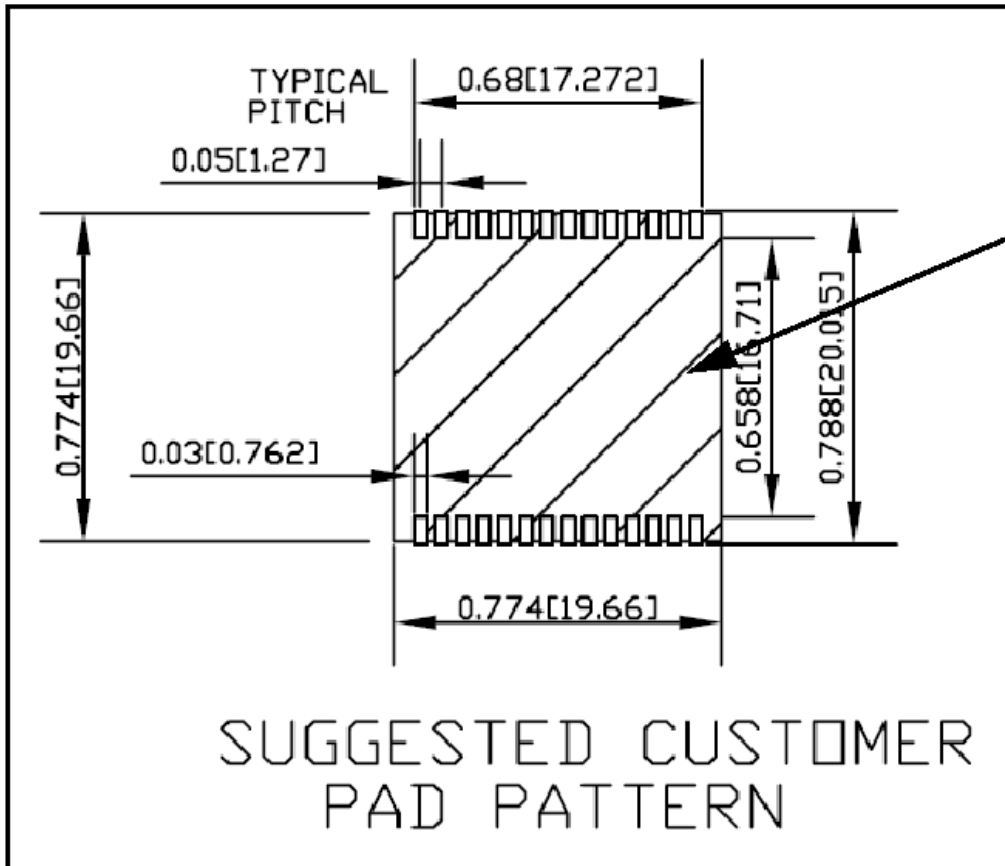

No solder mask or copper traces under the unit.

<DR-GPS module PAD Pattern>

Note: No solder mask or copper traces or vias or conductive elements under the unit

7.3 Suggested Customer Paste Pattern

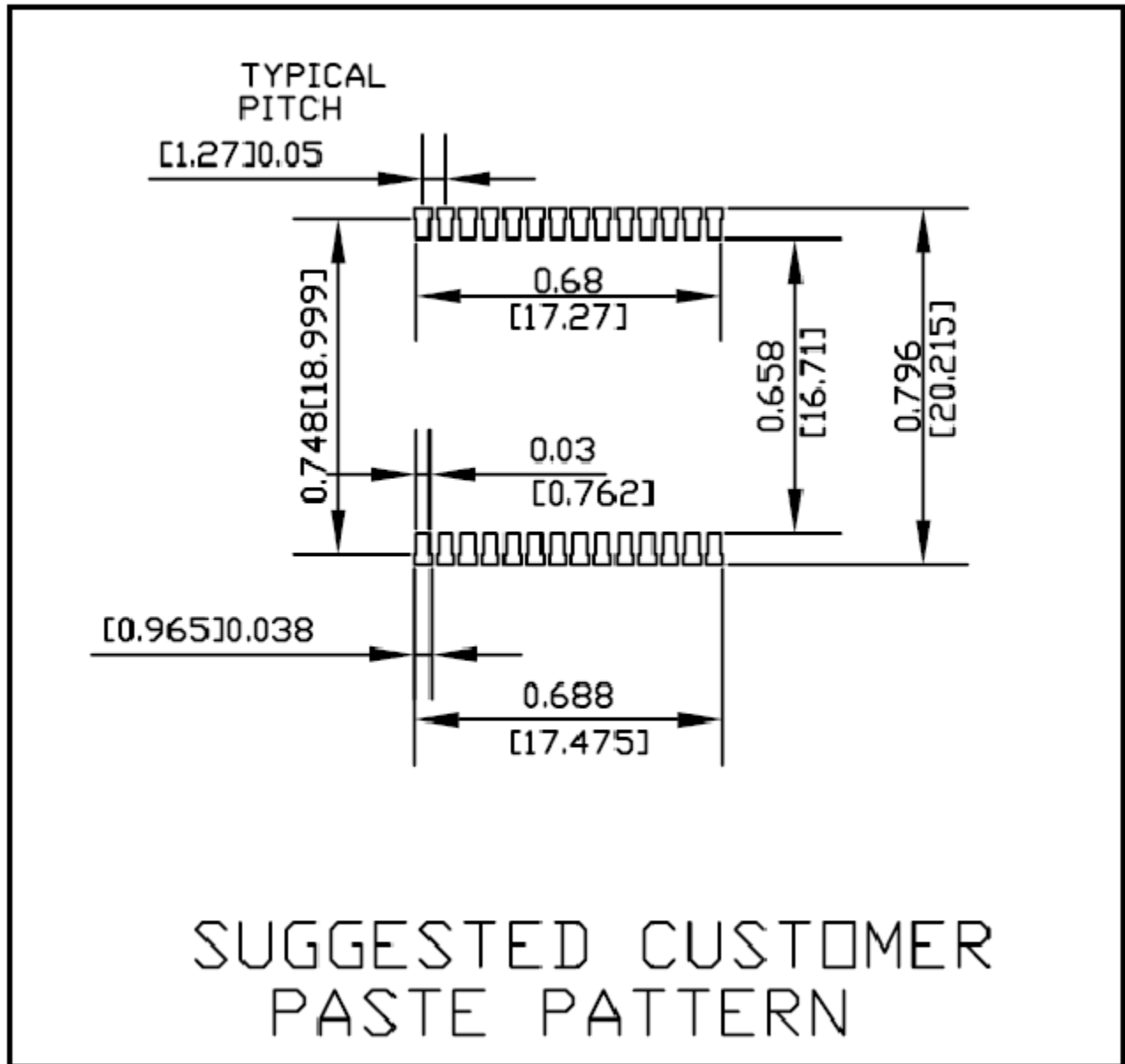

<DR-GPS module Paste Mask>

7.4 Co-planarity

Co-planarity of DR-GPS module is <0.2mm

7.5 Antenna Open/Short Detection and Protection

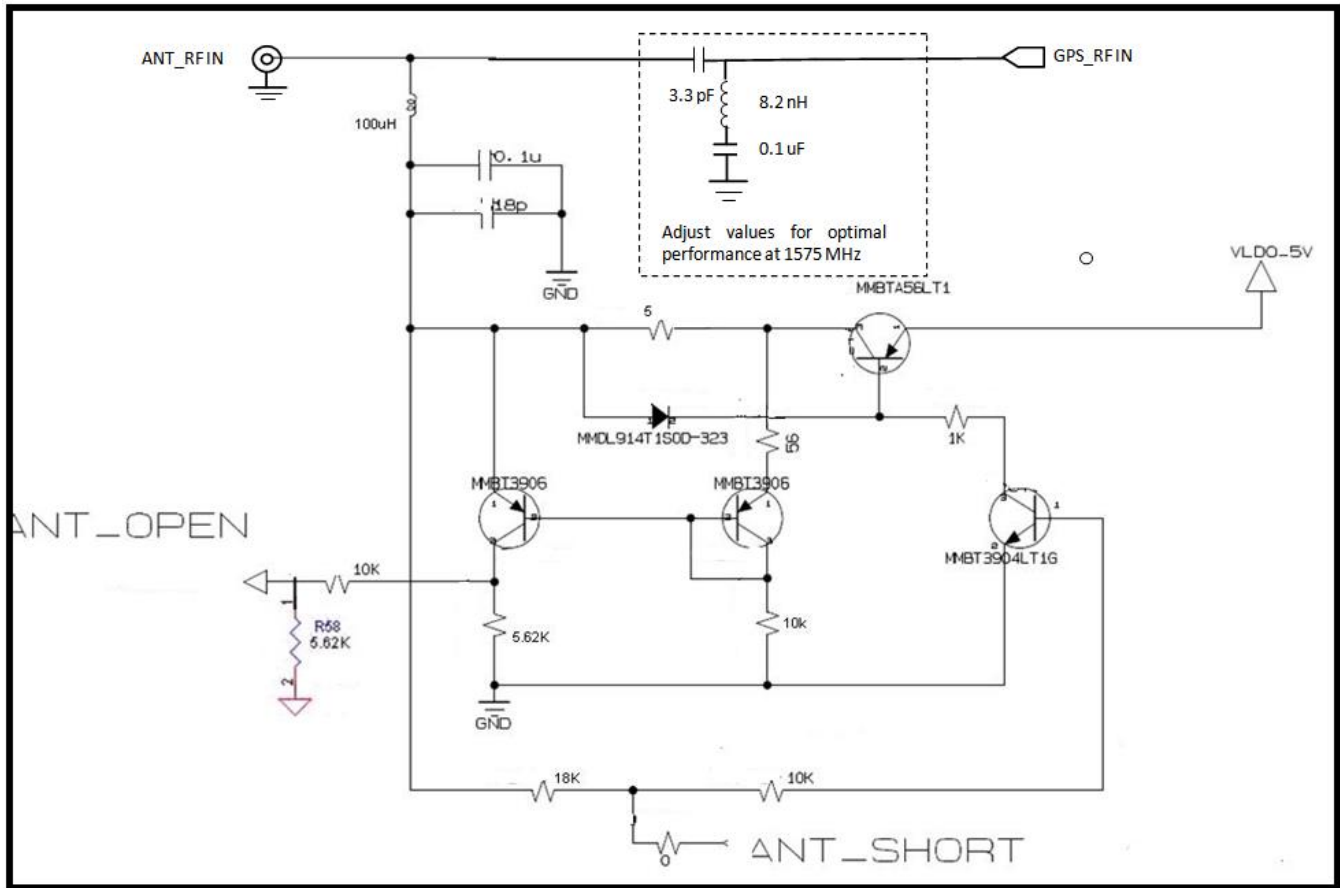

8 HANDLING

8.1 Moisture Precondition

Precautions must be taken to minimize the effects of the reflow thermal stress on the component. Plastic molding components for integrated circuit encapsulation are hygroscopic and absorb moisture dependent on the time and the environment. Absorbed moisture will vaporize during the rapid heating of the solder reflow process, generating pressure to all the interface areas in the package, which is followed by swelling, delamination and even cracking the plastic. Components that do not exhibit external cracking can have internal delamination or cracking which affects the yield and reliability.

This product is moisture sensitive: Level 3.

Do not open except under controlled conditions.

Shelf life in sealed bag: 12 months @ <40C and <90% RH.

- 1) Peak package body temperature 245 C.
- 2) After this bag is opened, devices that will be subjected to IR reflow vapor-phase reflow, or equivalent processing must be:
 - a) Mounted within 168 hrs @ factory conditions of <30C/60% RH or
 - b) Stored at < 20% RH.
- 3) Devices require baking, before mounting if:
 - a) Humidity card is >20% when read at 23C +/- 5C or
 - b) 2a or 2b are not met.
- 4) If baking is required, devices may be baked for 24 hrs minimum at 125 C +/- 5C.

8.2 Baking Procedure

If baking is necessary, Trimble recommends baking in a nitrogen purge oven.

Temperature: 125 Deg C

Duration: 24 Hours.

After Baking: Store in a nitrogen-purged cabinet or dry box to prevent absorption of moisture.

CAUTION: Repeated backing process will reduce the solderability

CAUTION: Do not bake the units within the tape and reel packaging.

8.3 Soldering Paste

Soldering diagrams and sections from above

The DR-GPS module itself is not hermetically sealed, we strongly recommend using the “No Clean” soldering paste and process. The castellation solder pad on this module is plated with silver plating. We recommend using Type 3 or above soldering paste to maximize the solder volume. Please see example of the solder paste below:

Solder paste: Kester EM909

Alloy composition: Sn96.5Ag3Cu.5 (SAC305) 96.5% Tin/ 3%Silver/ 0.5% Copper

Liquidus Temperature: 221 DegC

Stencil Thickness: 5 Mil (0.005")

Stencil opening requires 4-mil toe over paste in the X and Y directions.

Please consult solder paste manufacturer and the assembly process for the approved procedures.

8.4 Solder Reflow

A hot air convection oven is strongly recommended for solder reflow. For the lead-free solder reflow, we recommend using a nitrogen-purged oven to increase the solder wetting. Please references to IPC-610D for the lead free solder surface appearance.

CAUTION: Following the thermal reflow guidelines from the IPC-JEDEC J-STD-020C

The size of this module is 957 mm³. According to J-STD-020C, the peak component temperature during reflow is 245 +0 DegC.

8.5 Recommended Solder Profile

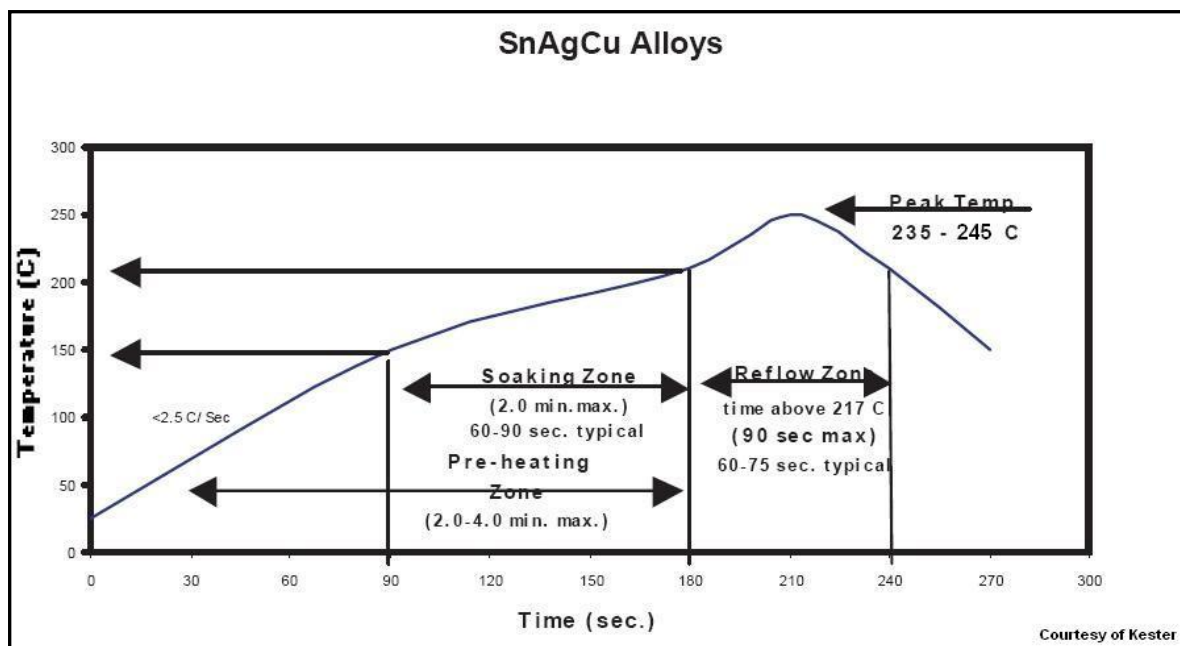

Customer will carefully select the final soldering thermal profile. The thermal profile depends on the choice of the solder paste, thickness and color of the carrier board, heat transfer and size of the penalization.

CAUTION: For a double sided surface-mount carrier board, the unit will be placed on the secondary side to prevent falling off during reflow.

Trimble Proprietary & Confidential

8.6 Optical Inspection

After soldering the DR-GPS module GPS module to the carrier board, please follow IPC-610 specification to visually inspect under 3X magnification lens for the following:

Verify that each pin is properly aligned with mount pad.

The pads are properly soldered.

Verify that no solder is bridged to the adjacent pads and X-ray the bottom pad if necessary.

8.7 Cleaning

When the DR-GPS module is attached to the user board, a cleaning process voids the warranty. Please use a “no-clean” process to eliminate the cleaning process. The silver plated DR-GPS module may discolor with cleaning agent or chlorinated faucet water. Any other form of cleaning solder residual may cause permanently damage and voids the warranty.

8.8 Repeated Wave Soldering

The DR-GPS module lead-free silver plated module can withstand two-reflow solder processes. If the unit must mount on the first side for surface-mount reflow, we suggest adding additional glue on the bottom of the module to prevent falling off when processing the second side.

8.9 Wave Soldering

The DR-GPS module cannot soak in the solder pot. If the carrier board is mixed with through-hole components with surface mount devices, it can process with one single lead-free wave process. The temperature of the unit will depend on the size and the thickness of the board. We recommend measuring the temperature on the module and keeping it under 180 Deg C.

8.10 Hand Soldering

For the lead-free DR-GPS module, we recommend using a lead-free solder core, such as Kester 275 Sn96.5/Ag3/Cu0.5 When soldering the module by hand, please keep the soldering iron below 260 degC.

8.11 Rework

The DR-GPS module can withstand one rework cycle. The module can heat up to the reflow temperature to precede the rework. Customers will never remove the metal shield and rework on the module itself.

8.12 Conformal Coating

Conformal coating on the DR-GPS module is not allowed. Conformal coating will void the warranty.

8.13 Metal Shield Grounding

This module is designed with numerous ground pins that provide the best immunity to the EMI and noise shielding. Any alternation in adding ground wires to the metal shield will be done at the customer's own risk.