

MEMS Thermal Sensors D6T

High Sensitivity Enables Detection of Stationary Human Presence

- OMRON's unique MEMS and ASIC technologies achieve a high SNR.
- Superior noise immunity with a digital output.
- High-precision area temperature detection with low cross-talk field of view characteristics.
- Application notes are available. (Contact Omron.)
- RoHS compliant.



Ordering Information

Element type	Model
4×4	D6T-44L-06
1×8	D6T-8L-06

Note: Static Sensitive Parts. Please refer to "Handling" in the Precautions Section of this datasheet.

Specifications

■ Ratings

Item	Specification
Power supply voltage	4.5 to 5.5 VDC
Storage temperature range	-10 to 60°C (with no icing or condensation)
Operating temperature range	0 to 50°C (with no icing or condensation)
Storage humidity range	85% max. (with no icing or condensation)
Operating humidity range	20% to 85% (with no icing or condensation)

■ Characteristics

Item		D6T-44L-06	D6T-8L-06
View angle (see note 1)	X direction	44.2°	62.8°
	Y direction	45.7°	6.0°
Object temperature output accuracy (See note 2)	Accuracy 1	±1.5°C max. Measurement conditions: V _{CC} = 5.0 V (1) Tx = 25°C, Ta = 25°C (2) Tx = 45°C, Ta = 25°C (3) Tx = 45°C, Ta = 45°C	
	Accuracy 2	±3.0°C max. Measurement conditions: V _{CC} = 5.0 V (4) Tx = 25°C, Ta = 45°C	
Current consumption		5 mA typical	

■ Functions

Item	Specification
Object temperature detection range (see note 2)	5 to 50°C
Reference temperature detection range (see note 2)	5 to 45°C
Output specifications	Digital values that correspond to the object temperature (Tx) and reference temperature (Ta) are output from a serial communications port.
Output form	Binary code (10 times the detected temperature (°C))
Communications form	I ² C compliant
Temperature resolution (NETD)	0.14°C

- Note:**
1. Refer to Field of View Characteristics in the Engineering Data section.
 2. Refer to Object Temperature Detection Range in the Engineering Data section.

Engineering Data

Field of View Characteristics

D6T-44L-06

Field of view in X Direction

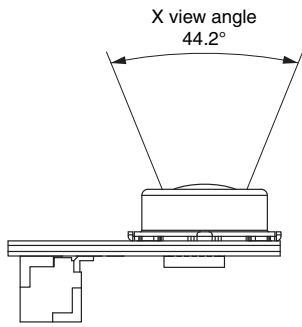

Field of view in Y Direction

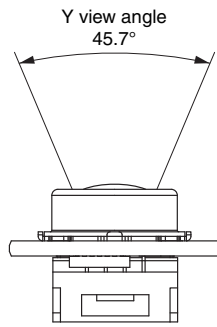

Detection Area for Each Pixel

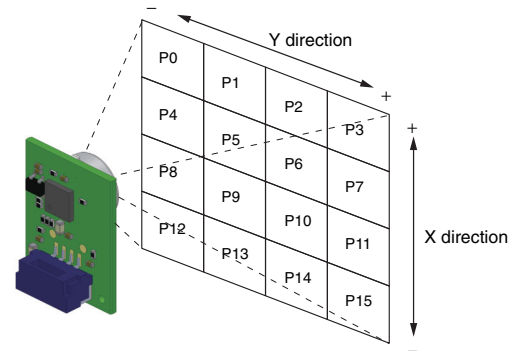

Note: Definition of view angle: Using the maximum Sensor output as a reference, the angular range where the Sensor output is 50% or higher when the angle of the Sensor is changed is defined as the view angle.

D6T-8L-06

Field of view in X Direction

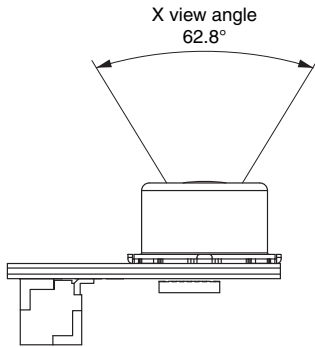

Field of view in Y Direction

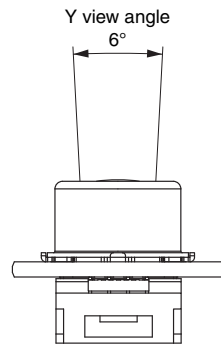

Detection Area for Each Pixel

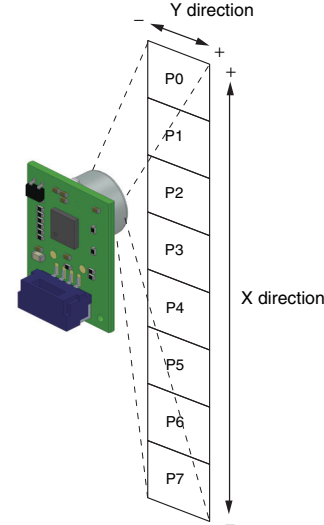

Note: Definition of view angle: Using the maximum Sensor output as a reference, the angular range where the Sensor output is 50% or higher when the angle of the Sensor is changed is defined as the view angle.

Object Temperature Detection Range

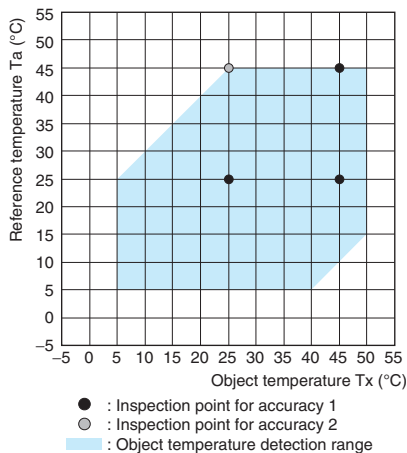

Connections

Thermal Sensor Configuration Diagram

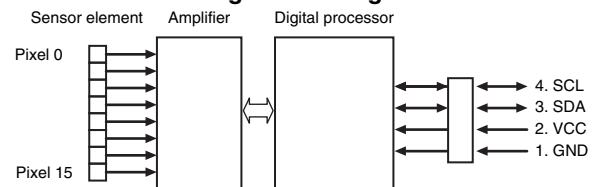

Note: The 1x8 type has pixels 0 to 7.

Terminal Arrangement

Terminal	Name	Function	Remarks
1	GND	Ground	
2	VCC	Positive power supply voltage input	
3	SDA	Serial data I/O line	Connect the open-drain SDA terminal to a pull-up resistor.
4	SCL	Serial clock input	Connect the open-drain SCL terminal to a pull-up resistor.

Dimensions

(Unit: mm)

D6T-44L-06

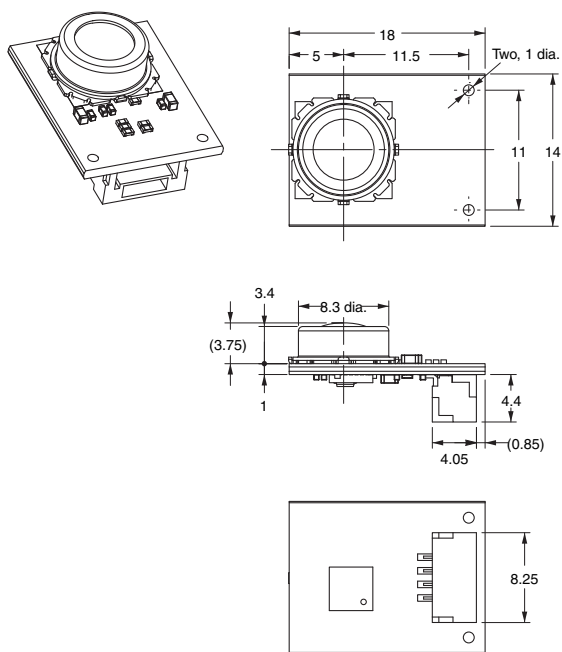

Supporting and Mounting Area (Shaded Portion)

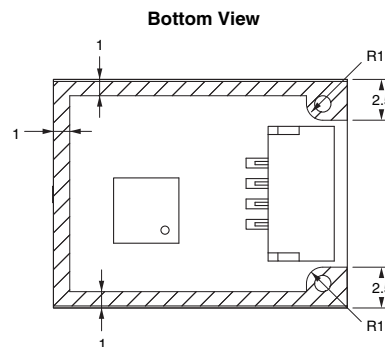
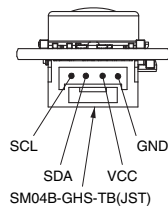
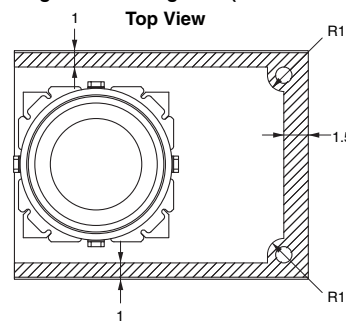

Note: Due to insulation distance limitations, do not allow metal parts to come into contact with the Sensor.

D6T-8L-06

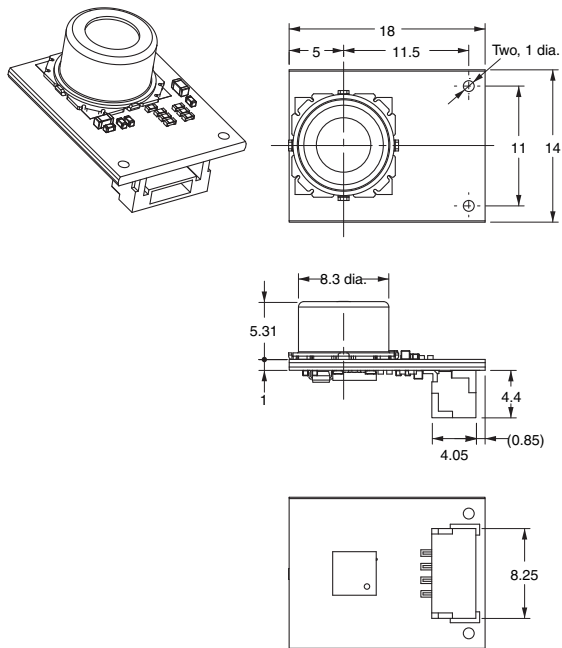

Supporting and Mounting Area (Shaded Portion)

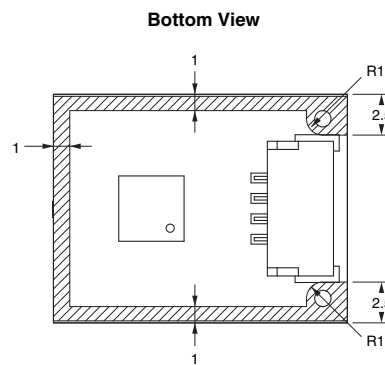
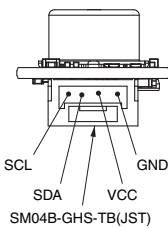
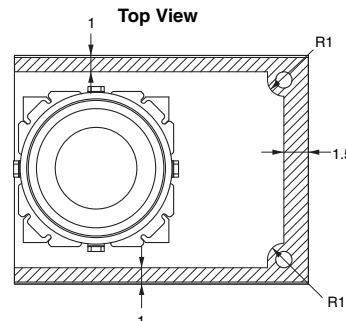

Note: Due to insulation distance limitations, do not allow metal parts to come into contact with the Sensor.

Note: Unless otherwise specified, a tolerance of ± 0.3 mm applies to all dimensions.

Safety Precautions

■ Precautions for Correct Use

Installation

- The Sensor may not achieve the characteristics given in this datasheet due to the ambient environment or installation location. Before using the Sensor, please acquire an adequate understanding and make a prior assessment of Sensor characteristics in your actual system.

Operating Environment

- Do not use the Sensor in locations where dust, dirt, oil, and other foreign matter will adhere to the lens. This may prevent correct temperature measurements.
- Do not use the Sensor in any of the following locations.
 - Locations where the Sensor may come into contact with water or oil
 - Outdoors
 - Locations subject to direct sunlight.
 - Locations subject to corrosive gases (in particular, chloride, sulfide, or ammonia gases).
 - Locations subject to extreme temperature changes
 - Locations subject to icing or condensation.
 - Locations subject to excessive vibration or shock.

Noise Countermeasures

- The Sensor does not contain any protective circuits. Never subject it to an electrical load that exceeds the absolute maximum ratings for even an instance. The circuits may be damaged. Install protective circuits as required so that the absolute maximum ratings are not exceeded.
- Keep as much space as possible between the Sensor and devices that generates high frequencies (such as high-frequency welders and high-frequency sewing machines) or surges.
- Attach a surge protector or noise filter on nearby noise-generating devices (in particular, motors, transformers, solenoids, magnetic coils, or devices that have an inductance component).
- In order to prevent inductive noise, separate the connector of the Sensor from power lines carrying high voltages or large currents. Using a shielded line is also effective.
- If a switching regulator is used, check that malfunctions will not occur due to switching noise from the power supply.

Handling

- This Sensor is a precision device. Do not drop it or subject it to excessive shock or force. Doing so may damage the Sensor or change its characteristics. Never subject the connector to unnecessary force. Do not use a Sensor that has been dropped.
- Take countermeasures against static electricity before you handle the Sensor.
 - Keep the humidity between 40 to 70%.
 - Use conductive or cotton type for gloves and finger cots.
 - Wear a wrist strap on either the right or left hand.
 - Put a conductive sheet (1 x 105 to 1 x 109Ω) on the working table and connect to ground with the resistance of 1 MΩ.
 - Hold the edge of the board so as not to touch the wiring, electric parts or surface of the lens.
- Turn OFF the power supply to the system before you install the Sensor. Working with the Sensor while the power supply is turned ON may cause malfunctions.
- Secure the Sensor firmly so that the optical axis does not move.
- Install the Sensor on a flat surface. If the installation surface is not even, the Sensor may be deformed, preventing correct measurements.
- Do not install the Sensor with screws. Screws may cause the resist to peel from the board. Secure the Sensor in a way that will not cause the resist to peel.
- Always check operation after you install the Sensor.
- Use the specified connector (PHR-4 from JST) and connect it securely so that it will not come off. If you solder directly to the connector terminals, the Sensor may be damaged.
- Make sure to wire the polarity of the terminals correctly. Incorrect polarity may damage the Sensor.
- Never attempt to disassemble the Sensor.

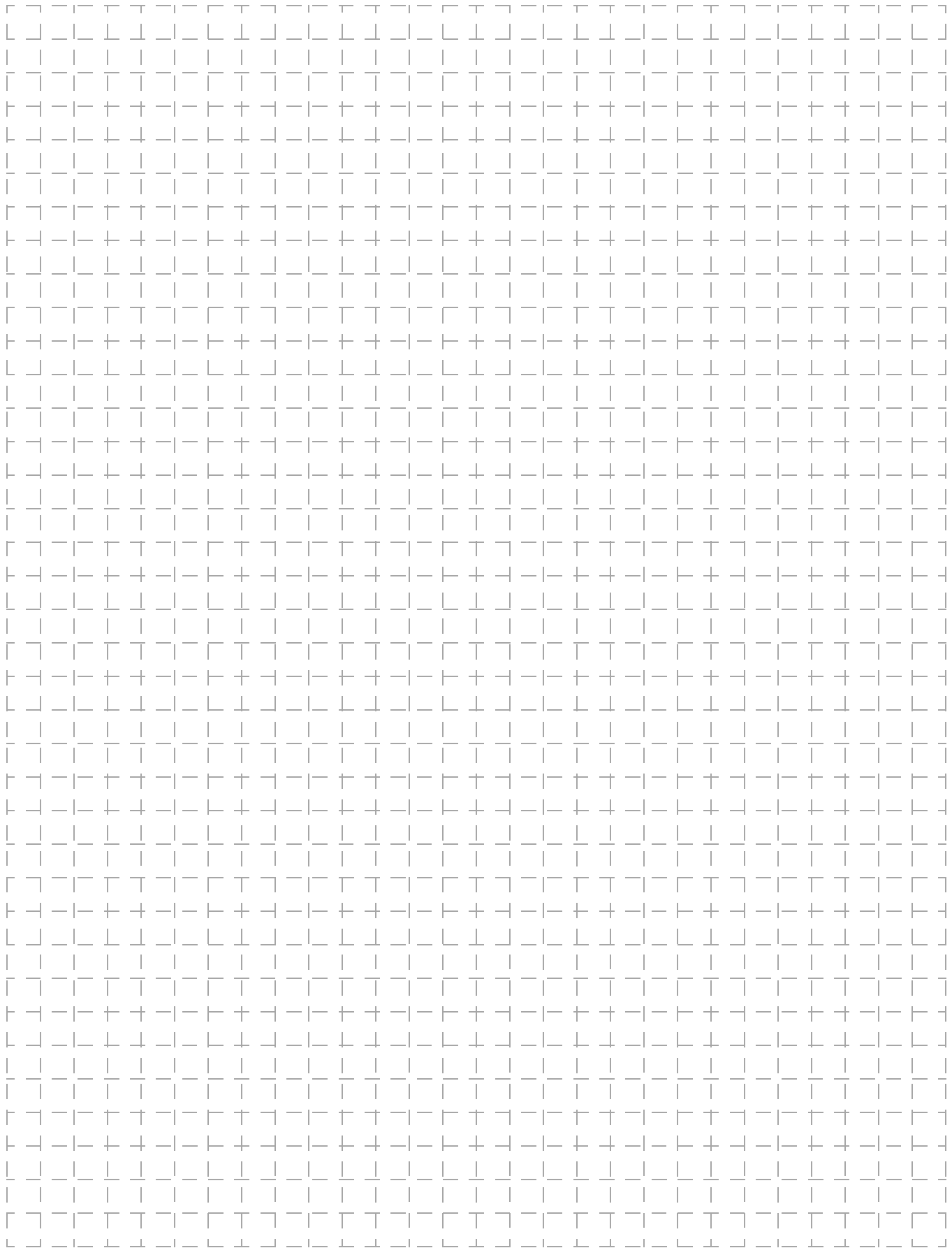

All sales are subject to Omron Electronic Components LLC standard terms and conditions of sale, which can be found at http://www.components.omron.com/components/web/webfiles.nsf/sales_terms.html

ALL DIMENSIONS SHOWN ARE IN MILLIMETERS.
To convert millimeters into inches, multiply by 0.03937. To convert grams into ounces, multiply by 0.03527.

OMRON[®]

**OMRON ELECTRONIC
COMPONENTS LLC**

55 E. Commerce Drive, Suite B
Schaumburg, IL 60173

847-882-2288

OMRON ON-LINE

Global - <http://www.omron.com>
USA - <http://www.components.omron.com>

Cat. No.A216-E-01a

11/12

Specifications subject to change without notice

Printed in USA

Mouser Electronics

Authorized Distributor

Click to View Pricing, Inventory, Delivery & Lifecycle Information:

[Omron:](#)

[D6T-44L-06](#) [D6T-8L-06](#)