

DATA SHEET

SA7025

Low-voltage 1GHz fractional-N
synthesizer

Product specification

1996 Aug 6

IC17 Data Handbook

1GHz low-voltage Fractional-N synthesizer

SA7025

DESCRIPTION

The SA7025 is a monolithic low power, high performance dual frequency synthesizer fabricated in QUBiC BiCMOS technology. Featuring Fractional-N division with selectable modulo 5 or 8 implemented in the Main synthesizer to allow the phase detector comparison frequency to be five or eight times the channel spacing. This feature reduces the overall division ratio yielding a lower noise floor and faster channel switching. The phase detectors and charge pumps are designed to achieve phase detector comparison frequencies up to 5MHz. A triple modulus prescaler (divide by 64/65/72) is integrated on chip with a maximum input frequency of 1.04GHz. Programming and channel selection are realized by a high speed 3-wire serial interface.

FEATURES

- Operation up to 1.04GHz
- Fast locking by "Fractional-N" divider
- Auxiliary synthesizer
- Digital phase comparator with proportional and integral charge pump output
- High speed serial input
- Low power consumption
- Programmable charge pump currents
- Supply voltage range 2.7 to 5.5V
- Excellent input sensitivity: $V_{RF_IN} = -20\text{dBm}$

APPLICATIONS

- NADC (North American Digital Cellular)
- PDC (Personal Digital Cellular)
- Cellular radio
- Spread-spectrum receivers

ORDERING INFORMATION

DESCRIPTION	TEMPERATURE RANGE	ORDER CODE	DWG #
20-Pin Plastic Shrink Small Outline Package (SSOP)	-40 to +85°C	SA7025DK	SOT266-1

ABSOLUTE MAXIMUM RATINGS

SYMBOL	PARAMETER	RATING	UNITS
V	Supply voltage, V_{DD} , V_{DDA} , V_{CCP}	-0.3 to +6.0	V
V_{IN}	Voltage applied to any other pin	-0.3 to ($V_{DD} + 0.3$)	V
T_{STG}	Storage temperature range	-65 to +150	°C
T_A	Operating ambient temperature range	-40 to +85	°C

NOTE: Thermal impedance (θ_{JA}) = 117°C/W. This device is ESD sensitive.

PIN CONFIGURATION

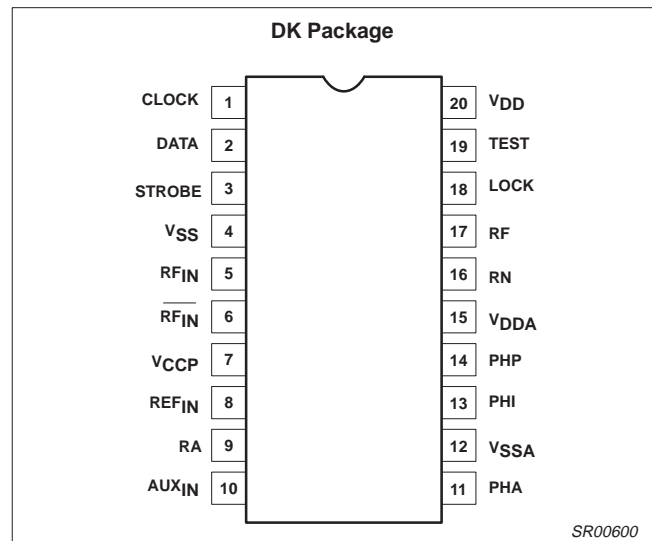

Figure 1. Pin Configuration

1GHz low-voltage Fractional-N synthesizer

SA7025

PIN DESCRIPTIONS

Symbol	Pin	Description
CLOCK	1	Serial clock input
DATA	2	Serial data input
STROBE	3	Serial strobe input
V _{SS}	4	Digital ground
RF _{IN}	5	Prescaler positive input
$\overline{\text{RF}}_{\text{IN}}$	6	Prescaler negative input
V _{CCP}	7	Prescaler positive supply voltage. This pin supplies power to the prescaler and RF input buffer
REF _{IN}	8	Reference divider input
RA	9	Auxiliary current setting; resistor to V _{SSA}
AUX _{IN}	10	Auxiliary divider input
PHA	11	Auxiliary phase detector output
V _{SSA}	12	Analog ground
PHI	13	Integral phase detector output
PHP	14	Proportional phase detector output
V _{DDA}	15	Analog supply voltage. This pin supplies power to the charge pumps, Auxiliary prescaler, Auxiliary and Reference buffers.
RN	16	Main current setting; resistor to V _{SSA}
RF	17	Fractional compensation current setting; resistor to V _{SSA}
LOCK	18	Lock detector output
TEST	19	Test pin; connect to V _{DD}
V _{DD}	20	Digital supply voltage. This pin supplies power to the CMOS digital part of the device

1GHz low-voltage Fractional-N synthesizer

SA7025

BLOCK DIAGRAM

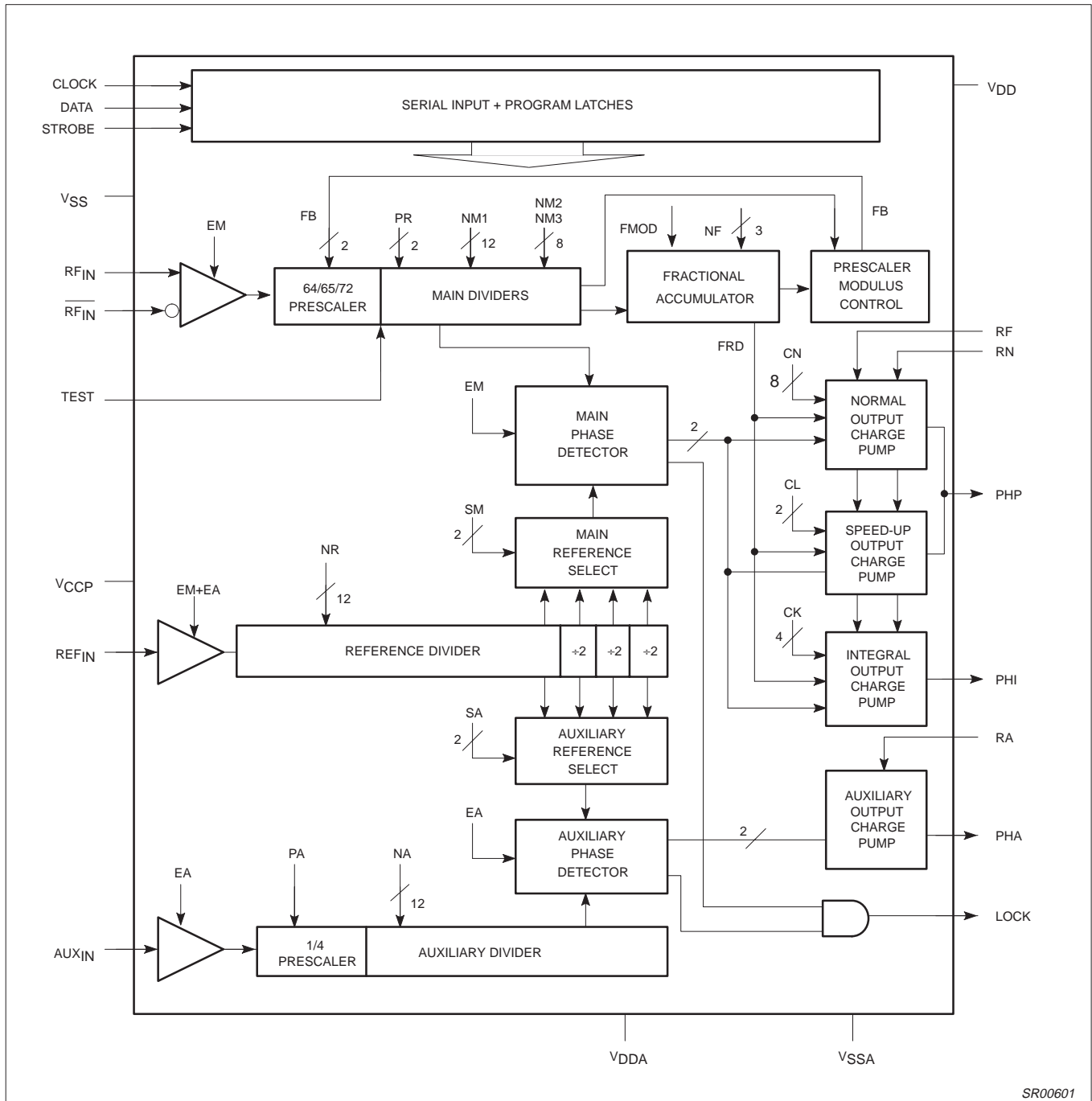

Figure 2. Block Diagram

SR00601

1GHz low-voltage Fractional-N synthesizer

SA7025

DC ELECTRICAL CHARACTERISTICS

 $V_{DD} = V_{DDA} = V_{CCP} = 3V$; $T_A = 25^\circ C$, unless otherwise specified.

SYMBOL	PARAMETER	TEST CONDITIONS	LIMITS			UNITS
			MIN	TYP	MAX	
V_{SUPPLY}	Recommended operating conditions	$V_{CCP} = V_{DD}$, $V_{DDA} \geq V_{DD}$	2.7		5.5	V
$I_{STANDBY}$	Total standby supply currents	$EM = EA = 0$, $I_{RN} = I_{RF} = I_{RA} = 0$		50	500	μA
Operational supply currents: $I = I_{DD} + I_{CCP} + I_{DDA}$; $I_{RN} = 25\mu A$, $I_{RA} = 25\mu A$, (see Note 5)						
I_{AUX}	Operational supply currents	$EM = 0$, $EA = 1$		3.5		mA
I_{MAIN}	Operational supply currents	$EM = 1$, $EA = 0$		5.5		mA
I_{TOTAL}	Operational supply currents	$EM = EA = 1$		7.5		mA
Digital inputs CLK, DATA, STROBE						
V_{IH}	High level input voltage range		$0.7 \times V_{DD}$		V_{DD}	V
V_{IL}	Low level input voltage range		0		$0.3 \times V_{DD}$	V
Digital outputs LOCK						
V_{OL}	Output voltage LOW	$I_O = 2mA$			0.4	V
V_{OH}	Output voltage HIGH	$I_O = -2mA$	$V_{DD} - 0.4$			V
Charge pumps: $V_{DDA} = 3V / I_{RX} = 25\mu A$ or $V_{DDA} = 5V / I_{RX} = 62.5\mu A$, V_{PHX} in range, unless otherwise specified. (See Note 16)						
$ I_{RX} $	Setting current range for any setting resistor	$2.7V < V_{DDA} < 5.5V$		25		μA
		$4.5V < V_{DDA} < 5.5V$		62.5		
V_{PHOUT}	Output voltage range		0.7		$V_{DDA} - 0.8$	V
Charge pump PHA						
$ I_{PHA} $	Output current PHA	$I_{RA} = -62.5\mu A$; $V_{PHA} = V_{DDA}/2^{13}$	400	500	600	μA
		$I_{RA} = -25\mu A$; $V_{PHA} = V_{DDA}/2$	160	200	240	
$\frac{\Delta I_{PHP_A}}{I_{PHP_A}}$	Relative output current variation PHA	$I_{RA} = -62.5\mu A^2$, ¹³		2	6	%
ΔI_{PHA_M}	Output current matching PHA pump	$V_{DDA} = 3V$, $I_{RA} = 25\mu A$			± 50	μA
		$V_{DDA} = 5V$, $I_{RA} = 62.5\mu A$			± 65	
Charge pump PHP, normal mode^{1, 4, 6} $V_{RF} = V_{DDA}$						
$ I_{PHP_N} $	Output current PHP	$I_{RN} = -62.5\mu A$; $V_{PHP} = V_{DDA}/2^{13}$	440	550	660	μA
		$I_{RN} = -25\mu A$; $V_{PHP} = V_{DDA}/2$	175	220	265	
$\frac{\Delta I_{PHP_N}}{I_{PHP_N}}$	Relative output current variation PHP	$I_{RN} = -62.5\mu A^2$, ¹³		2	6	%
$\Delta I_{PHP_N_M}$	Output current matching PHP normal mode	$V_{DDA} = 3V$, $I_{RA} = 25\mu A$			± 50	μA
		$V_{DDA} = 5V$, $I_{RA} = 62.5\mu A$			± 65	
Charge pump PHP, speed-up mode^{1, 4, 7} $V_{RF} = V_{DDA}$						
$ I_{PHP_S} $	Output current PHP	$I_{RN} = -62.5\mu A$; $V_{PHP} = V_{DDA}/2^{13}$	2.20	2.75	3.30	mA
		$I_{RN} = -25\mu A$; $V_{PHP} = V_{DDA}/2$	0.85	1.1	1.35	
$\frac{\Delta I_{PHP_S}}{I_{PHP_S}}$	Relative output current variation PHP	$I_{RN} = -62.5\mu A^2$, ¹³		2	6	%
$\Delta I_{PHP_S_M}$	Output current matching PHP speed-up mode	$V_{DDA} = 3V$, $I_{RA} = 25\mu A$			± 250	μA
		$V_{DDA} = 5V$, $I_{RA} = 62.5\mu A$			± 300	
Charge pump PHI, speed-up mode^{1, 4, 8} $V_{RF} = V_{DDA}$						
$ I_{PHI} $	Output current PHI	$I_{RN} = -62.5\mu A$; $V_{PHI} = V_{DDA}/2^{13}$	4.4	5.5	6.6	mA
		$I_{RN} = -25\mu A$; $V_{PHI} = V_{DDA}/2$	1.75	2.2	2.65	
$\frac{\Delta I_{PHI}}{I_{PHI}}$	Relative output current variation PHI	$I_{RN} = -62.5\mu A^2$, ¹³		2	8	%
ΔI_{PHI_M}	Output current matching PHI pump	$V_{DDA} = 3V$, $I_{RA} = 25\mu A$			± 500	μA
		$V_{DDA} = 5V$, $I_{RA} = 62.5\mu A$			± 600	
Fractional compensation PHP, normal mode^{1, 9} $V_{RN} = V_{DDA}$, $V_{PHP} = V_{DDA}/2$						
$I_{PHP_F_N}$	Fractional compensation output current PHP vs F_{RD}^3	$I_{RF} = -62.5\mu A$; $F_{RD} = 1$ to 7^{13}	-625	-400	-250	nA
		$I_{RF} = -25\mu A$; $F_{RD} = 1$ to 7	-250	-180	-100	

1GHz low-voltage Fractional-N synthesizer

SA7025

DC ELECTRICAL CHARACTERISTICS (Continued)

SYMBOL	PARAMETER	TEST CONDITIONS	LIMITS			UNITS
			MIN	TYP	MAX	
Fractional compensation PHP, speed up mode^{1, 10} $V_{PHP} = V_{DDA}$, $V_{RN} = V_{DDA}$						
$I_{PHP_F_S}$	Fractional compensation output current PHP vs F_{RD}^3	$I_{RF} = -62.5\mu A; F_{RD} = 1 \text{ to } 7^{13}$	-3.35	-2.0	-1.1	μA
		$I_{RF} = -25\mu A; F_{RD} = 1 \text{ to } 7$	-1.35	-1.0	-0.5	
	Pump leakage		-20		20	nA
Fractional compensation PHI, speed up mode^{1, 11} $V_{PHP} = V_{DDA}/2$, $V_{RN} = V_{DDA}$						
I_{PHL_F}	Fractional compensation output current PHI vs F_{RD}^3	$I_{RF} = -62.5\mu A; F_{RD} = 1 \text{ to } 7^{13}$	-5.4	-4.0	-2.6	μA
		$I_{RF} = -25\mu A; F_{RD} = 1 \text{ to } 7$	-2.15	-1.6	-1.05	
Charge pump leakage currents, charge pump not active						
I_{PHP_L}	Output leakage current PHP; normal mode ¹	$V_{PHP} = 0.7 \text{ to } V_{DDA} - 0.8$		0.1	10	nA
I_{PHL_L}	Output leakage current PHI; normal mode ¹	$V_{PHI} = 0.7 \text{ to } V_{DDA} - 0.8$		0.1	10	nA
I_{PHA_L}	Output leakage current PHA	$V_{PHA} = 0.7 \text{ to } V_{DDA} - 0.8$		0.1	10	nA

AC ELECTRICAL CHARACTERISTICS

$V_{DD} = V_{DDA} = V_{CCP} = 3V$; $T_A = 25^\circ C$; $f_{RF_IN} = 1GHz$, input level = -20dBm; unless otherwise specified. Test Circuit, Figure 4. The parameters listed below are tested using automatic test equipment to assure consistent electrical characteristics. The limits do not represent the ultimate performance limits of the device. Use of an optimized RF layout will improve many of the listed parameters.

SYMBOL	PARAMETER	TEST CONDITIONS	LIMITS			UNITS
			MIN	TYP	MAX	
Main divider						
f_{RF_IN}	Input signal frequency	Direct coupled input ¹⁴			1.04	GHz
		1000pF input coupling			1.04	
V_{RF_IN}	Input sensitivity	1040MHz	-20		0	dBm
Reference divider ($V_{DD} = V_{DDA} = 3V$ or $V_{DD} = 3V / V_{DDA} = 5V$)						
f_{REF_IN}	Input signal frequency	$2.7 < V_{DD}$ and $V_{DDA} < 5.5V$			25	MHz
		$2.7 < V_{DD}$ and $V_{DDA} < 4.5V$			30	
V_{REF_IN}	Input signal range, AC coupled	$2.7 < V_{DD}$ and $V_{DDA} < 5.5V$	500			mV _{P-P}
		$2.7 < V_{DD}$ and $V_{DDA} < 4.5V$	300			
Z_{REF_IN}	Reference divider input impedance ¹⁵			100		k Ω
				3		pF
Auxiliary divider						
f_{AUX_IN}	Input signal frequency		0		50	MHz
	PA = "0", prescaler enabled	$4.5V \leq V_{DDA} \leq 5.5V$	0		150	
	Input signal frequency		0		30	
	PA = "1", prescaler disabled	$4.5V \leq V_{DDA} \leq 5.5V$	0		40	
V_{AUX_IN}	Input signal range, AC coupled		200			mV _{P-P}
Z_{AUX_IN}	Auxiliary divider input impedance			100		k Ω
				3		pF
Serial interface¹⁵						
f_{CLOCK}	Clock frequency				10	MHz
t_{SU}	Set-up time: DATA to CLOCK, CLOCK to STROBE		30			ns
t_H	Hold time; CLOCK to DATA		30			ns
t_W	Pulse width; CLOCK		30			ns
	Pulse width; STROBE	B, C, D, E words	30			
In-Loop Performance¹⁷ $V_{DDA} = 5V$, $V_{DD} = 2.7V$						
R_{MM}	Main loop residual FM	$FVCO = 1030MHz$		300	600	Hz

1GHz low-voltage Fractional-N synthesizer

SA7025

AC ELECTRICAL CHARACTERISTICS (continued)

SYMBOL	PARAMETER	TEST CONDITIONS	LIMITS			UNITS
			MIN	TYP	MAX	
t _{SW}	Pulse width; STROBE	A word, PR = '01'	$\frac{1}{f_{VCO}} \cdot (NM2 \cdot 65) + t_W$			ns
		A word, PR = '10'	$\frac{1}{f_{VCO}} \cdot [(NM2 \cdot 65) + (NM3 + 1) \cdot 72] + t_W$			

NOTES:

- When a serial input "A" word is programmed, the main charge pumps on PHP and PHI are in the "speed up mode" as long as STROBE = H. When this is not the case, the main charge pumps are in the "normal mode".
- The relative output current variation is defined thus:

$$\frac{\Delta I_{OUT}}{I_{OUT}} = 2 \cdot \frac{(I_2 - I_1)}{|(I_2 + I_1)|}$$
; with $V_1 = 0.7V$, $V_2 = V_{DDA} - 0.8V$ (see Figure 3).
- F_{RD} is the value of the 3 bit fractional accumulator.
- Monotonicity is guaranteed with C_N = 0 to 255.
- Power supply current measured with V_{DD} = V_{CCP} = 3V, V_{DDA} = 5V, f_{RF IN} = 915.99MHz, XTAL at 21.36MHz, AUX at 85.92MHz (PA = '0'), Main comp frequency = 240kHz, Auxiliary comp frequency = 120kHz, CN = 160, CL = 0, CK = 0. Internal registers NM1 = 52, NM2 = 0, NM3 = 4, PR = '10', SM = '00', SA = '01', NA = 179, NF = 5, FMOD = 8, NR = 89, PA = 0, IRN = IRA = IRF = 25μA, lock condition, normal mode. Operational supply current = I_{DDA} + I_{DD} + I_{CCP}.
- Specification condition: CN = 255
- Specification conditions:
 - CN = 255; CL = 1, or
 - CN = 75; CL = 3
- Typical output current |I_{PHI}| = -I_{RN} × CN × 2^(CL+1) × CK/32:
 - CN = 160; CL = 3; CK = 1, or
 - CN = 160; CL = 2; CK = 2, or
 - CN = 160; CL = 1; CK = 4, or
 - CN = 160; CL = 0; CK = 8
- Any RFD, CL = 1 for speed-up pump. The integral pump is intended for switching only and the fractional compensation is not guaranteed.
- Specification conditions: F_{RD} = 1 to 7; CL = 1.
- Specification conditions:
 - F_{RD} = 1 to 7; CL = 1; CK = 2, or
 - F_{RD} = 1 to 7; CL = 2; CK = 1.
- The matching is defined by the sum of the P and the N pump for a given output voltage.
- Limited analog supply voltage range 4.5 to 5.5V.
- For f_{IN} < 50MHz, low frequency operation requires DC-coupling and a minimum input slew rate of 32V/μs.
- Guaranteed by design.
- Close in noise for the charge pumps is tested on a sample basis in a typical application in order to eliminate parts outside the normal distribution.
- F_{XTAL} = 14.4MHz, V_{XTAL} = 500mV_{P-P}, comparison frequency = 200kHz, Loop bandwidth = 5kHz, Audio filter = 300Hz to 15kHz.

1GHz low-voltage Fractional-N synthesizer

SA7025

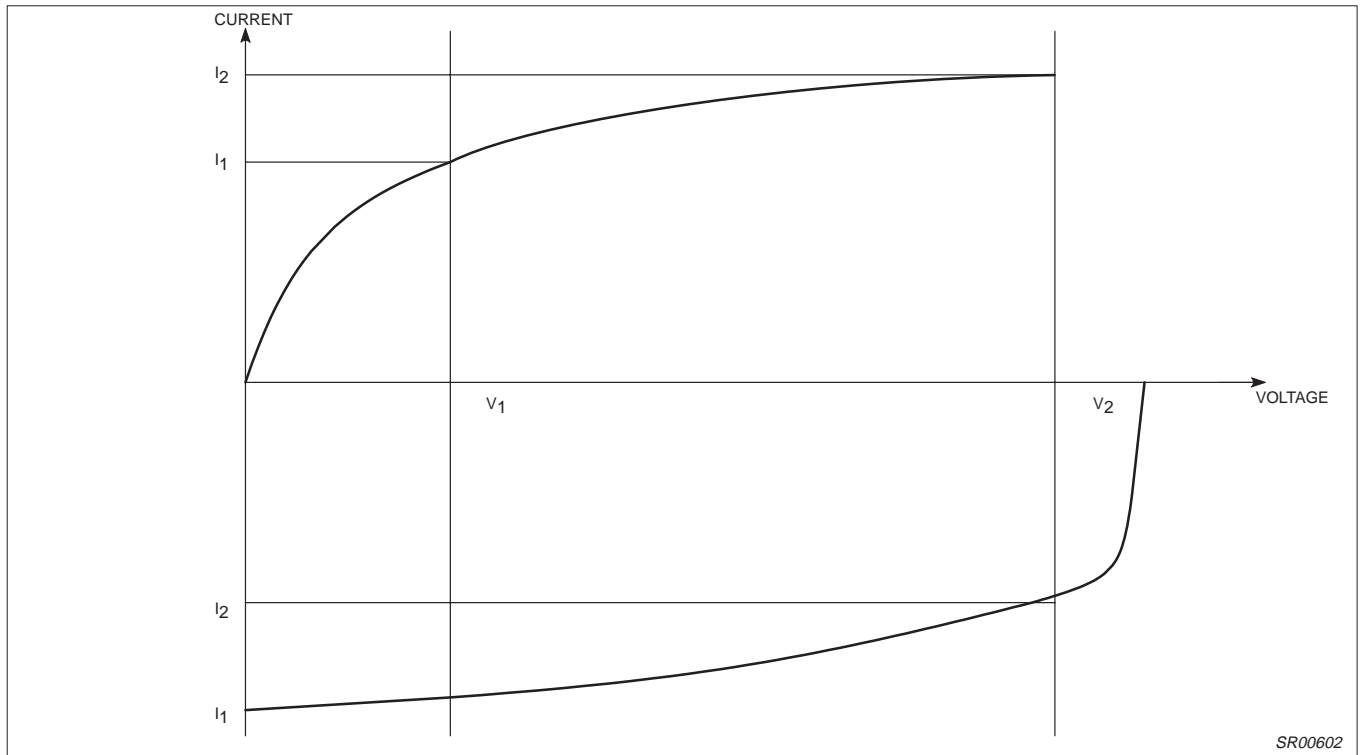

Figure 3. Relative Output Current Variation

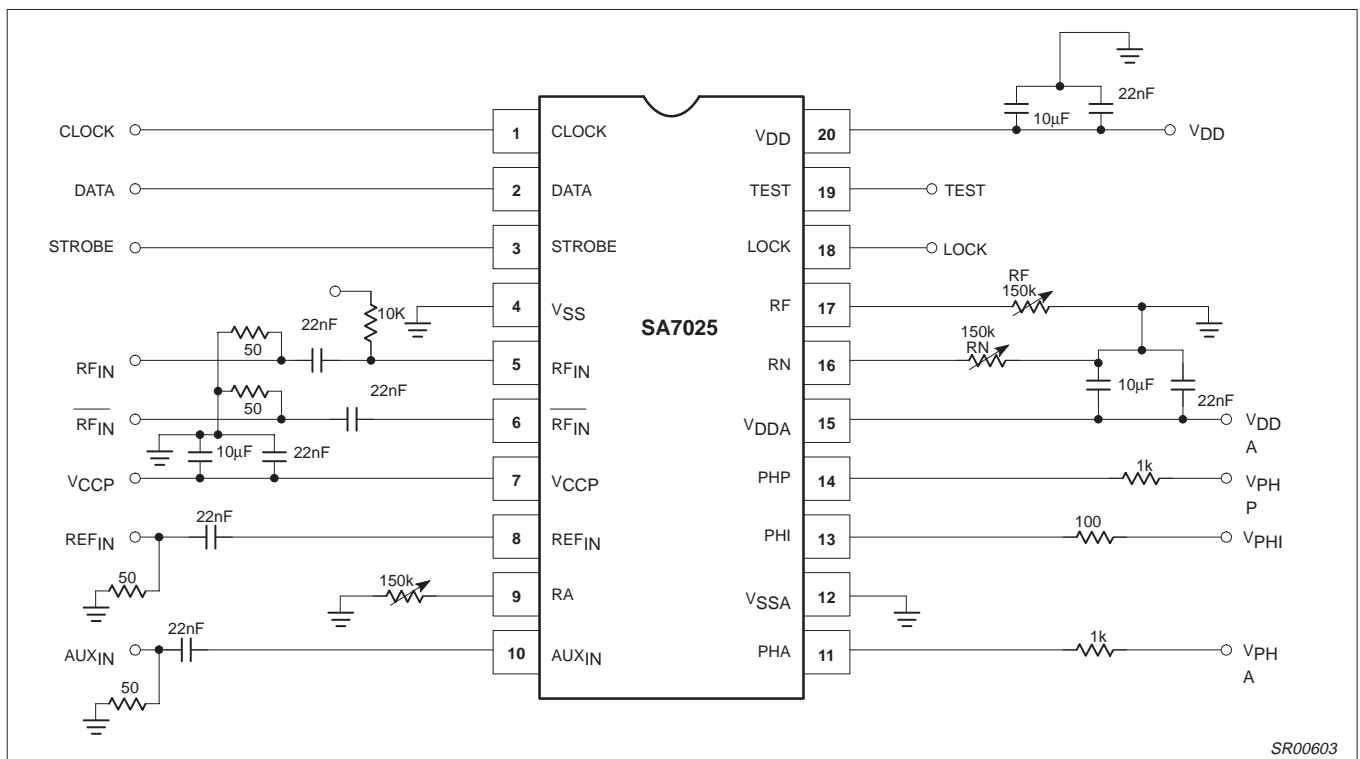

Figure 4. Test Circuit

1GHz low-voltage Fractional-N synthesizer

SA7025

AC TIMING CHARACTERISTICS

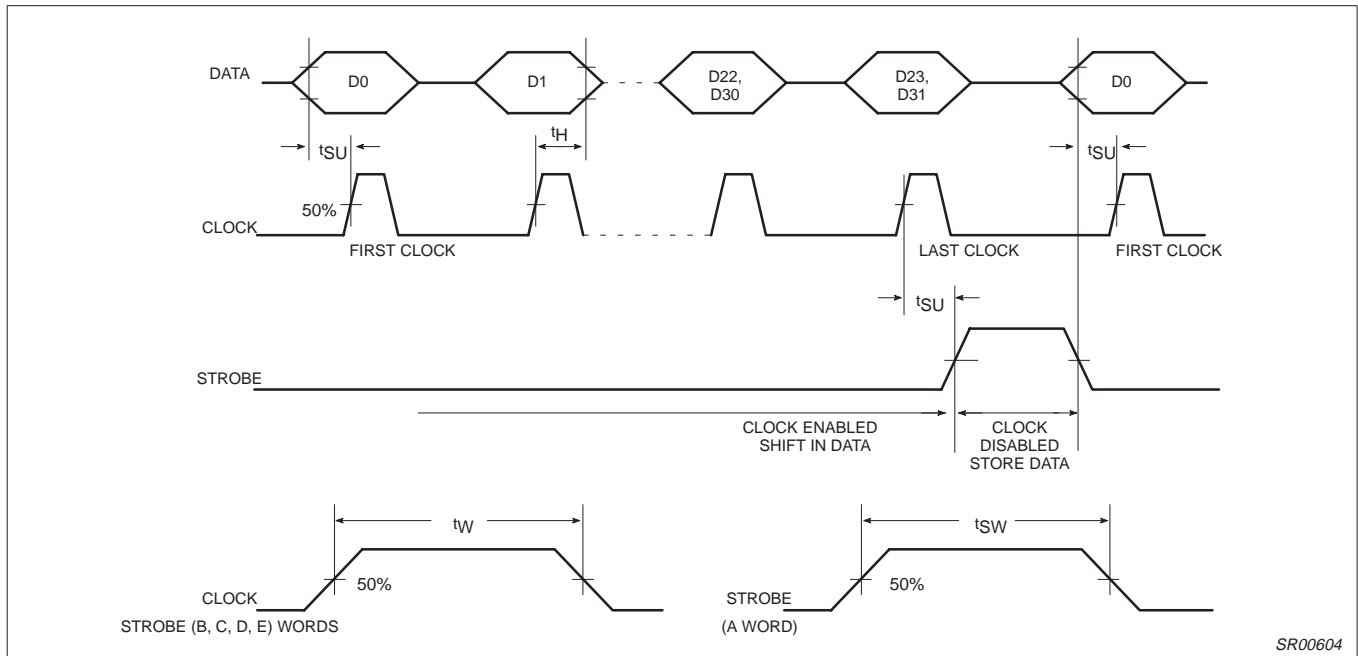

Figure 5. Serial Input Timing Sequence

FUNCTIONAL DESCRIPTION

Serial Input Programming

The serial input is a 3-wire input (CLOCK, STROBE, DATA) to program all counter ratios, DACs, selection and enable bits. The programming data is structured into 24 or 32 bit words; each word includes 1 or 4 address bits. Figure 5 shows the timing diagram of the serial input. When the STROBE = L, the clock driver is enabled and on the positive edges of the CLOCK the signal on DATA input is clocked into a shift register. When the STROBE = H, the clock is disabled and the data in the shift register remains stable. Depending on the 1 or 4 address bits the data is latched into different working registers or temporary registers. In order to fully program the synthesizer, 4 words must be sent: D, C, B and A. Figure 6 and Table 1 shows the format and the contents of each word. The E word is for testing purposes only. The E (test) word is reset when programming the D word. The data for CN and PR is stored by the B word in temporary registers. When the A word is loaded, the data of these temporary registers is loaded together with the A word into the work registers which avoids false temporary main divider input. CN is only loaded from the temporary registers when a short 24 bit A0 word is used. CN will be directly loaded by programming a long 32 bit A1 word. The flag LONG in the D word determines whether A0 (LONG = "0") or A1 (LONG = "1") format is applicable. The A word contains new data for the main divider.

Main Divider Synchronization

The A word is loaded only when a main divider synchronization signal is also active in order to avoid phase jumps when reprogramming the main divider. The synchronization signal is generated by the main divider. The signal is active while the NM1 divider is counting down from the programmed value. The new A word will be loaded after the NM1 divider has reached its terminal count; also, at this time a main divider output pulse will be sent to the main phase detector. The loading of the A word is disabled while the NM2 or NM3 dividers are counting up to their programmed

values. Therefore, the new A word will be correctly loaded provided that the STROBE signal has been at an active high value for at least a minimum number of VCO input cycles at RF_{IN} or \overline{RF}_{IN} .

$$t_{\text{strobe_min}} = \frac{1}{f_{\text{VCO}}} (NM_2 \cdot 65) + t_W \text{ for PR = '01'}$$

$$t_{\text{strobe_min}} = \frac{1}{f_{\text{VCO}}} [NM_2 \cdot 65 + (NM_3 + 1) \cdot 72] + t_W \text{ for PR = '10'}$$

Programming the A word means also that the main charge pumps on output PHP and PHI are set into the speed-up mode as long as the STROBE is H.

Auxiliary Divider

The input signal on AUX_IN is amplified to logic level by a single-ended CMOS input buffer, which accepts low level AC coupled input signals. This input stage is enabled if the serial control bit EA = "1". Disabling means that all currents in the input stage are switched off. A fixed divide by 4 is enabled if PA = "0". This divider has been optimized to accept a high frequency input signal. If PA = "1", this divider is disabled and the input signal is fed directly to the second stage, which is a 12-bit programmable divider with standard input frequency (40MHz). The division ratio can be expressed as:

$$\text{if PA = "0": } N = 4 \times NA$$

$$\text{if PA = "1": } N = NA; \text{ with } NA = 4 \text{ to } 4095$$

Reference Divider

The input signal on REF_IN is amplified to logic level by a single-ended CMOS input buffer, which accepts low level AC coupled input signals. This input stage is enabled by the OR function of the serial input bits EA and EM. Disabling means that all currents in the input stage are switched off. The reference divider consists of a programmable divider by NR (NR = 4 to 4095) followed by a three bit binary counter. The 2 bit SM register (see Figure 7) determines which of the 4 output pulses is selected as the main

1GHz low-voltage Fractional-N synthesizer

SA7025

phase detector input. The 2 bit SA register determines the selection of the auxiliary phase detector signal.

Main Divider

The differential inputs are amplified (to internal ECL logic levels) and provide excellent sensitivity (–20dBm at 1GHz) making the prescaler ideally suited to directly interface to a VCO as integrated on the SA620 RF gain stage, VCO and mixer device. The internal triple modulus prescaler feedback loop FB controls the selection of the divide by ratios 64/65/72, and reduces the minimum system division ratio below the typical value required by standard dual modulus (64/65) devices.

This input stage is enabled when serial control bit EM = “1”. Disabling means that all currents in the prescaler are switched off.

The main divider is built up by a 12 bit counter plus a sign bit. Depending on the serial input values NM1, NM2, NM3, and the prescaler select PR, the counter will select a prescaler ratio during a number of input cycles according to Table 2 and Table 3.

The loading of the work registers NM1, NM2, NM3 and PR is synchronized with the state of the main counter, to avoid extra phase disturbance when switching over to another main divider ratio as explained in the Serial Input Programming section.

At the completion of a main divider cycle, a main divider output pulse is generated which will drive the main phase comparator. Also, the fractional accumulator is incremented with NF. The

accumulator works modulo Q. Q is preset by the serial control bit FMOD to 8 when FMOD = “1”. Each time the accumulator overflows, the feedback to the prescaler will select one cycle using prescaler ratio R2 instead of R1.

As shown above, this will increase the overall division ratio by 1 if $R2 = R1 + 1$. The mean division ratio over Q main divider will then be

$$NQ = N + \frac{NF}{Q}$$

Programming a fraction means the prescaler with main divider will divide by N or N + 1. The output of the main divider will be modulated with a fractional phase ripple. This phase ripple is proportional to the contents of the fractional accumulator FRD, which is used for fractional current compensation.

Phase Detectors

The auxiliary and main phase detectors are a two D-type flip-flop phase and frequency detector shown in Figure 8. The flip-flops are set by the negative edges of output signals of the dividers. The rising edge of the signal, L, will reset the flip-flops after both flip-flops have been set. Around zero phase error this has the effect of delaying the reset for 1 reference input cycle. This avoids non-linearity or deadband around zero phase error. The flip-flops drive on-chip charge pumps. A source current from the charge pump indicates the VCO frequency will be increased; a sink current indicates the VCO frequency will be decreased.

1GHz low-voltage Fractional-N synthesizer

SA7025

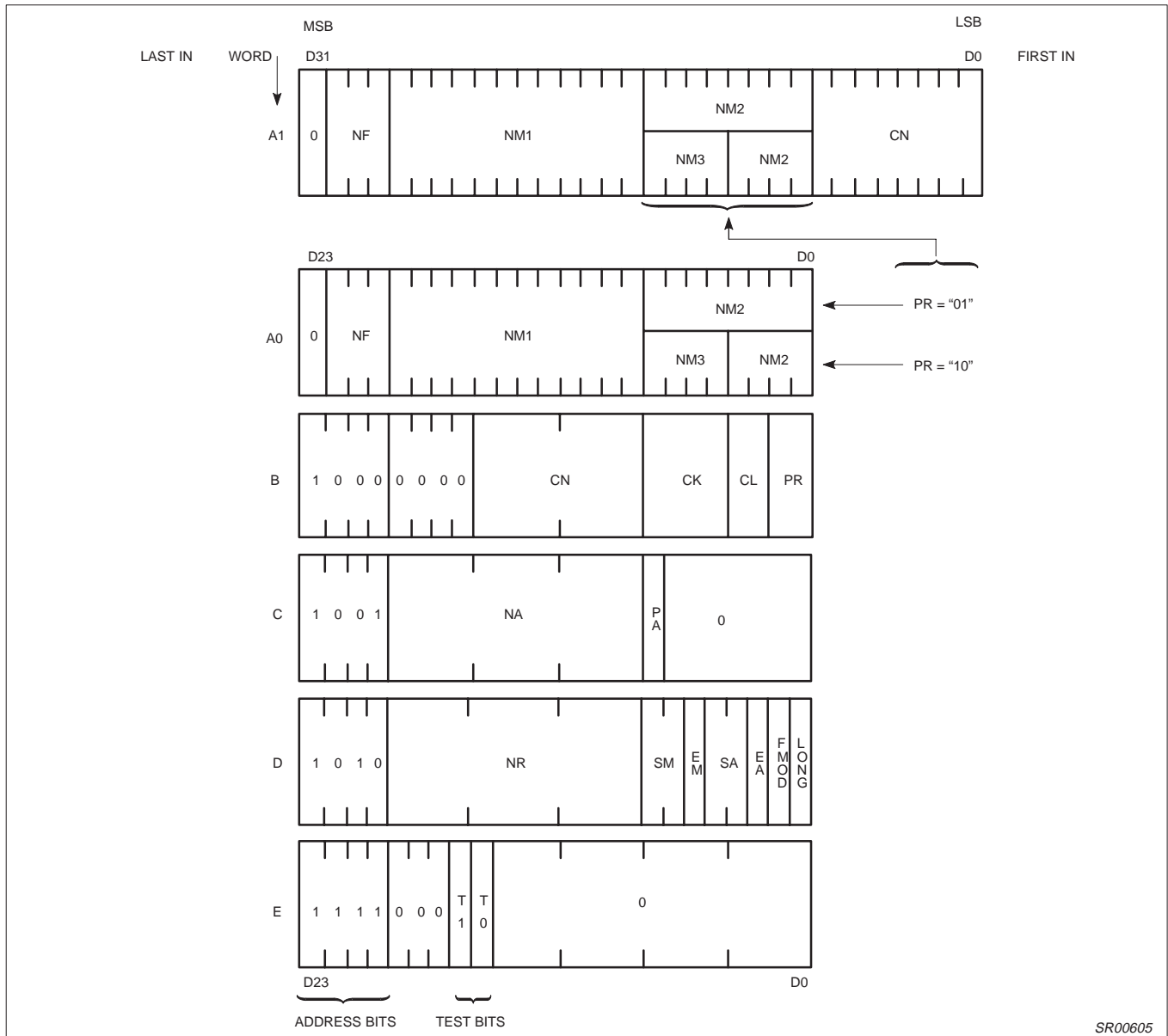

Figure 6. Serial Input Word Format

SR00605

Current Settings

The SA7025 has 3 current setting pins: RA, RN and RF. The active charge pump currents and the fractional compensation currents are linearly dependent on the current connected between the current setting pin and V_{SS} . The typical value R (current setting resistor) can be calculated with the formula:

$$R = \frac{V_{DDA} - 0.9 - 150 \sqrt{I_R}}{I_R}$$

The current can be set to zero by connecting the corresponding pin to V_{DDA} .

Auxiliary Output Charge Pumps

The auxiliary charge pumps on pin PHA are driven by the auxiliary phase detector and the current value is determined by the external resistor RA at pin RA. The active charge pump current is typically:

$$|I_{PHA}| = 8 \cdot I_{RA}$$

Main Output Charge Pumps and Fractional Compensation Currents

The main charge pumps on pin PHP and PHI are driven by the main phase detector and the current value is determined by the current at pin RN and via a number of DACs which are driven by registers of the serial input. The fractional compensation current is determined by the current at pin RF, the contents of the fractional accumulator FRD and a number of DACs driven by registers from the serial input. The timing for the fractional compensation is derived from the reference divider. The current is on during 1 input reference cycle before and 1 cycle after the output signal to the phase comparator. Figure 9 shows the waveforms for a typical case.

1GHz low-voltage Fractional-N synthesizer

SA7025

Table 1. Function Table

Symbol	Bits	Function
NM1	12	Number of main divider cycles when prescaler modulus = 64*
NM2	8 if PR = "01" 4 if PR = "10"	Number of main divider cycles when prescaler modulus = 65*
NM3	4 if PR = "10"	Number of main divider cycles when prescaler modulus = 72*
PR	2	Prescaler type in use PR = "01": modulus 2 prescaler (64/65) PR = "10": modulus 3 prescaler (64/65/72)
NF	3	Fractional-N increment
FMOD	1	Fractional-N modulus selection flag "1": modulo 8 "0": modulo 5
LONG	1	A word format selection flag "0": 24 bit A0 format "1": 32 bit A1 format
CN	8	Binary current setting factor for main charge pumps
CL	2	Binary acceleration factor for proportional charge pump current
CK	4	Binary acceleration factor for integral charge pump current
EM	1	Main divider enable flag
EA	1	Auxiliary divider enable flag
SM	2	Reference select for main phase detector
SA	2	Reference select for auxiliary phase detector
NR	12	Reference divider ratio
NA	12	Auxiliary divider ratio
PA	1	Auxiliary prescaler mode: PA = "0": divide by 4 PA = "1": divide by 1

*Not including reset cycles and Fractional-N effects.

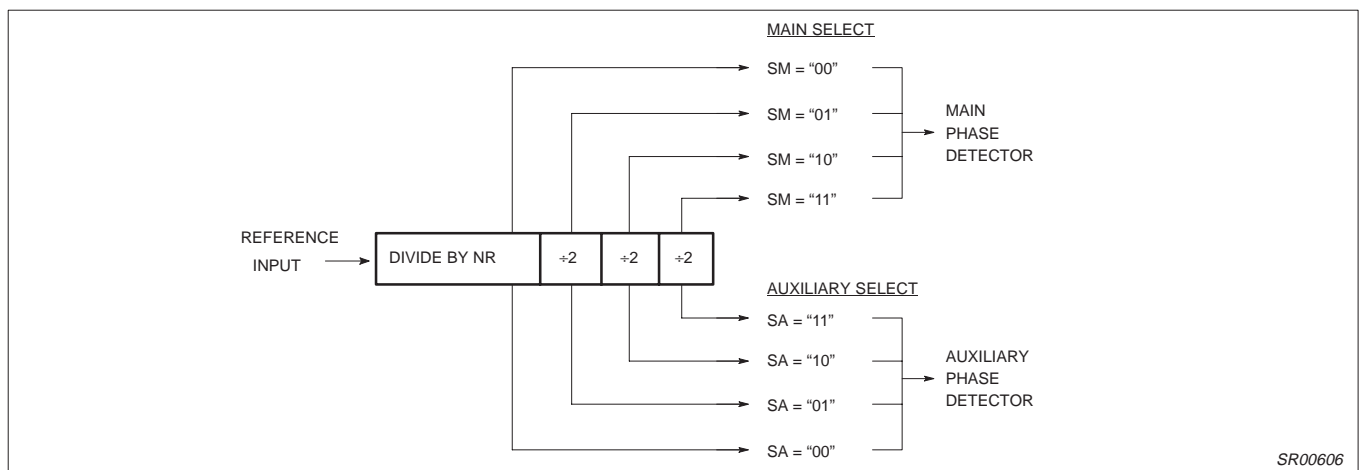

Figure 7. Reference Divider

Table 2. Prescaler Ratio

The total division ratio from prescaler to the phase detector may be expressed as:	
if PR = "01"	$N = (NM1 + 2) \times 64 + NM2 \times 65$ $N' = (NM1 + 1) \times 64 + (NM2 + 1) \times 65 \text{ (*)}$
if PR = "10"	$N = (NM1 + 2) \times 64 + NM2 \times 65 + (NM3 + 1) \times 72$ $N' = (NM1 + 1) \times 64 + (NM2 + 1) \times 65 + (NM3 + 1) \times 72 \text{ (*)}$
(*) When the fractional accumulator overflows the prescaler ratio = 65 (64 + 1) and the total division ratio $N' = N + 1$	

1GHz low-voltage Fractional-N synthesizer

SA7025

Table 3. PR Modulus

PR	Modulus Prescaler	Bit Capacity		
		NM1	NM2	NM3
01	2	12	8	–
10	3	12	4	4

When the serial input A word is loaded, the output circuits are in the “speed-up mode” as long as the STROBE is H, else the “normal mode” is active. In the “normal mode” the current output PHP is:

$$I_{PHP_N} = I_{PHP} + I_{PHP_comp}$$

where:

$$|I_{PHP}| = \frac{CN \cdot I_{RN}}{32} \quad \text{:charge pump current}$$

$$|I_{PHP_comp}| = FRD \cdot \frac{I_{RF}}{128} \quad \text{:fractional comp. current}$$

The current in PHI is zero in “normal mode”.

In “speed-up mode” the current in output PHP is:

$$I_{PHP_S} = I_{PHP} + I_{PHP_comp}$$

$$|I_{PHP}| = \left(\frac{CN \cdot I_{RN}}{32} \right) (2^{CL+1} + 1)$$

$$|I_{PHP_comp}| = \left(\frac{FRD \cdot I_{RF}}{128} \right) (2^{CL+1} + 1)$$

In “speed-up mode” the current in output PHI is:

$$I_{PHI_S} = I_{PHI} + I_{PHI_comp}$$

where:

$$|I_{PHI}| = \left(\frac{I_{RN} \cdot CN}{32} \right) (2^{CL+1}) \text{ CK}$$

$$|I_{PHI_comp}| = \left(\frac{I_{RF} \cdot FRD}{128} \right) (2^{CL+1}) \text{ CK}$$

Figure 9 shows that for proper fractional compensation, the area of the fractional compensation current pulse must be equal to the area of the charge pump ripple output. This means that the current setting on the input RN, RF is approximately:

$$\frac{I_{RN}}{I_{RF}} = \frac{(Q \cdot f_{VCO})}{(3 \cdot CN \cdot F_{INR})}$$

where:

- Q = fractional-N modulus
- $f_{VCO} = f_{INM} \times N$, input frequency of the prescaler
- $F_{INR} =$ input frequency of the reference divider

PHI pump is meant for switching only. Current and compensation are not as accurate as PHP.

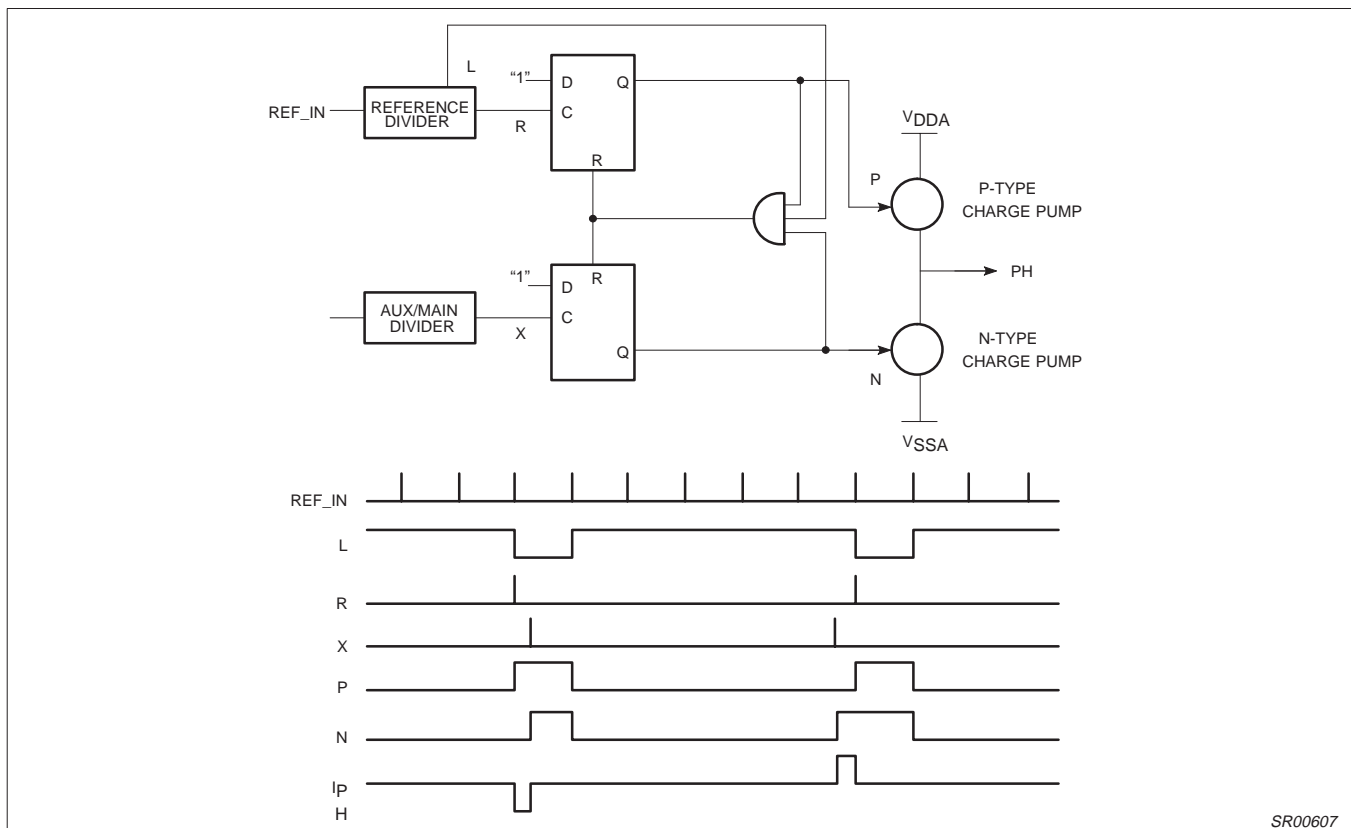

Figure 8. Phase Detector Structure with Timing

SR00607

1GHz low-voltage Fractional-N synthesizer

SA7025

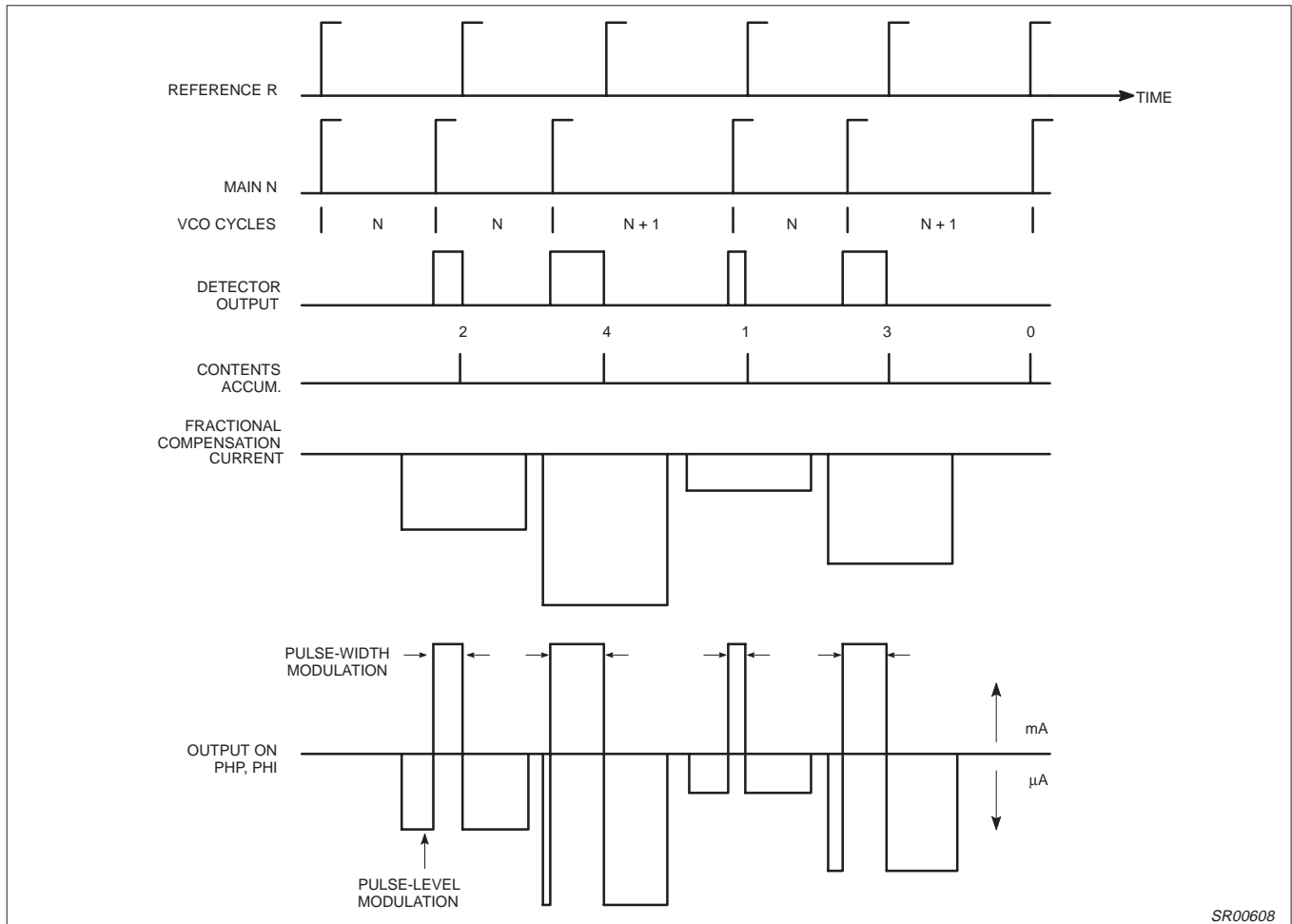

Figure 9. Waveforms for NF = 2, Fraction = 0.4

Lock Detect

The output LOCK is H when the auxiliary phase detector AND the main phase detector indicates a lock condition. The lock condition is defined as a phase difference of less than +1 cycle on the reference input REF_IN. The lock condition is also fulfilled when the relative counter is disabled (EM = "0" or respectively EA = "0") for the main, respectively auxiliary counter.

Test Modes

The lock output is selectable as f_{REF} , f_{AUX} , f_{MAIN} and lock. Bits T1 and T0 of the E word control the selection (see Figures 6 and 10).

If T1 = T0 = Low, or if the E-word is not sent, the lock output is configured as the normal lock output described in the Lock Detect section.

If T1 = Low and T0 = High, the lock output is configured as f_{REF} . The signal is the buffered output of the reference divider NR and the 3-bit binary counter SM. The f_{REF} signal appears as normally low and pulses high whenever the divider reaches terminal count from the value programmed into the NR and SM registers. The f_{REF} signal can be used to verify the divide ratio of the Reference divider.

If T1 = High and T0 = Low, the lock output is configured as f_{AUX} . The signal is normally high and pulses low whenever the divider reaches terminal count from the value programmed into the NA and

PA registers. The f_{AUX} signal can be used to verify the divide ratio of the Auxiliary divider.

If T1 = High and T0 = High, the lock output is configured as f_{MAIN} . The signal is the buffered output of the MAIN divider. The f_{MAIN} signal appears as normally high and pulses low whenever the divider reaches terminal count from the value programmed into the NM1, NM2 or NM3 registers. The f_{MAIN} signal can be used to verify the divide ratio of the MAIN divider and the prescaler.

1GHz low-voltage Fractional-N synthesizer

SA7025

Test Pin

The Test pin, Pin 19, is a buffered logic input which is exclusively ORed with the output of the prescaler. The output of the XOR gate is the input to the MAIN divider. The Test pin must be connected to V_{DD} during normal operation as a synthesizer. This pin can be used as an input for verifying the divide ratio of the MAIN divider; while in this condition the input to the prescaler, RF_{IN} , may be connected to V_{CCP} through a 10kΩ resistor in order to place prescaler output into a known state.

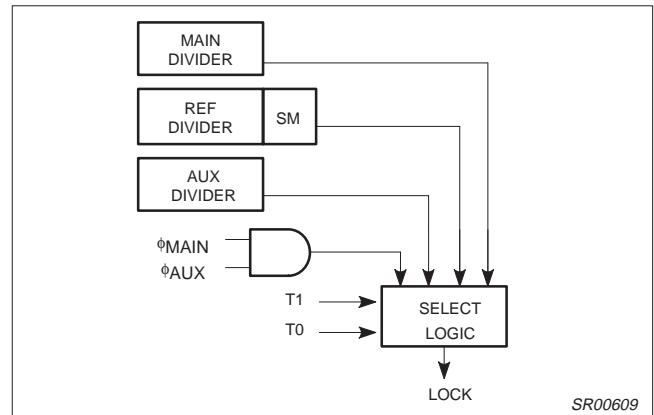

Figure 10. Test Mode Diagram

PIN FUNCTIONS

PIN No.	PIN MNEMONIC	DC V	EQUIVALENT CIRCUIT	PIN No.	PIN MNEMONIC	DC V	EQUIVALENT CIRCUIT
1	CLOCK	—		9	RA	1.35	
2	DATA	—		16	RN	1.35	
3	STROBE	—		17	RF	1.35	
19	TEST	—		5	RF_{IN}	2.1	
5	RF_{IN}	2.1	11	PHA	—		
6	$\overline{RF_{IN}}$	2.1	13	PHI	—		
8	REF_{IN}	1.8	10	REF_{IN}	1.8		
10	AUX_{IN}	1.8	18	LOCK	—		

Figure 11. Pin Functions

1GHz low-voltage Fractional-N synthesizer

SA7025

TYPICAL PERFORMANCE CHARACTERISTICS

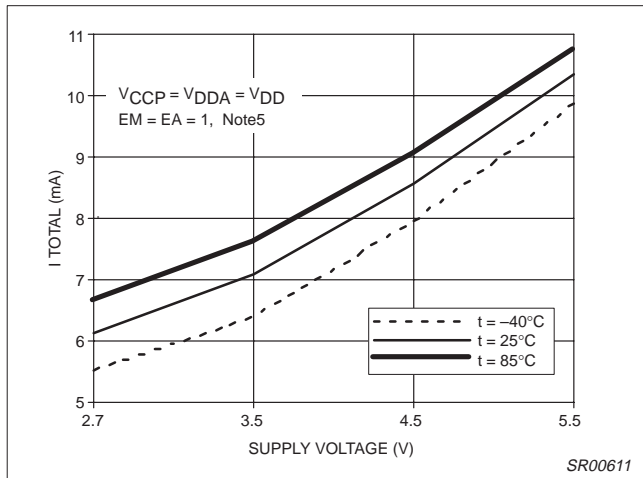

Figure 12. Operational Supply Current vs Supply Voltage and Temperature

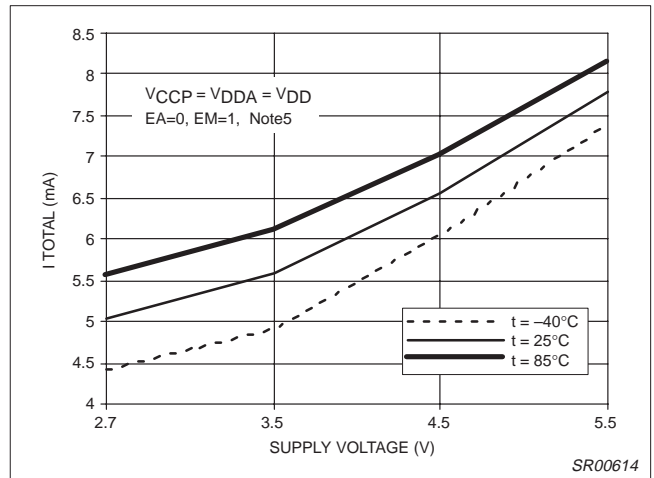

Figure 15. Main Operational Supply Current vs Supply Voltage and Temperature

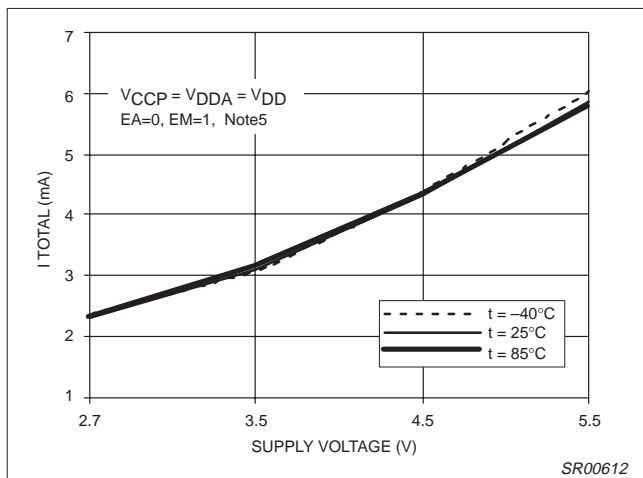

Figure 13. Auxiliary Operational Supply Current vs Supply Voltage and Temperature

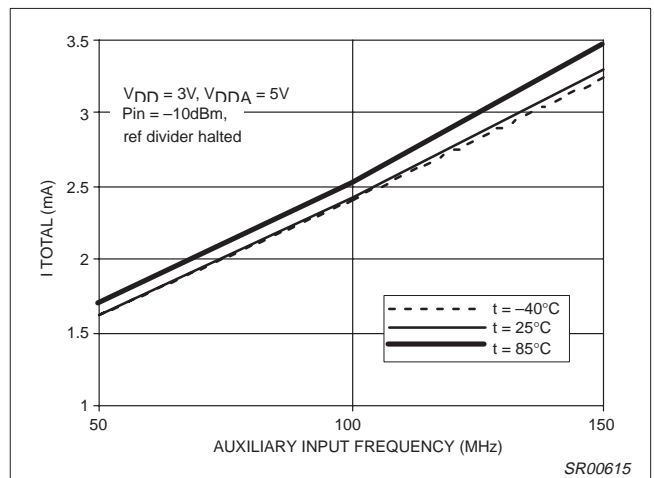

Figure 16. Auxiliary Operational Supply Current vs Frequency and Temperature

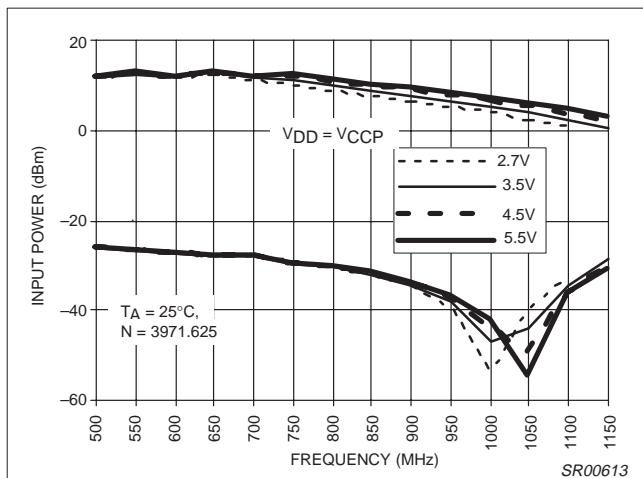

Figure 14. Main Divider Input Power vs frequency and Supply

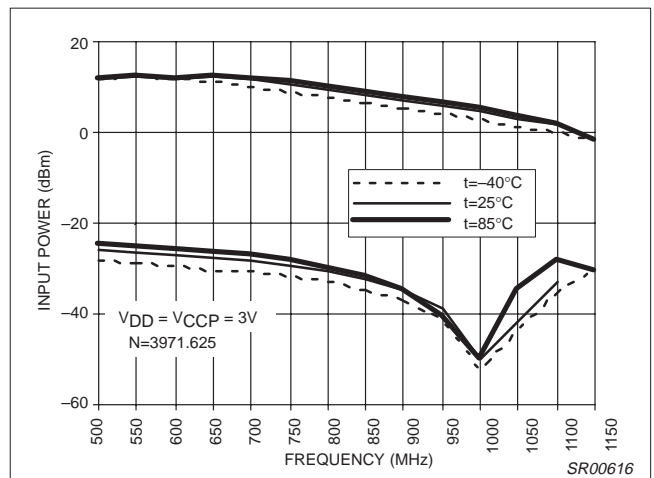

Figure 17. Main Divider Input Power vs Frequency and Temperature

1GHz low-voltage Fractional-N synthesizer

SA7025

TYPICAL PERFORMANCE CHARACTERISTICS (continued)

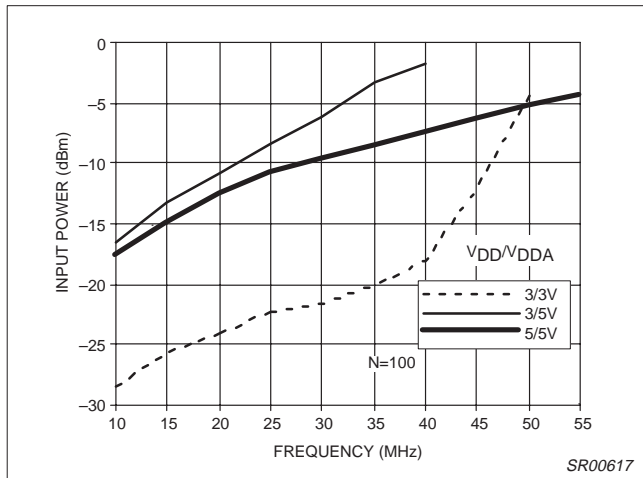

Figure 18. Reference Divider Minimum Input Power vs frequency and Supply

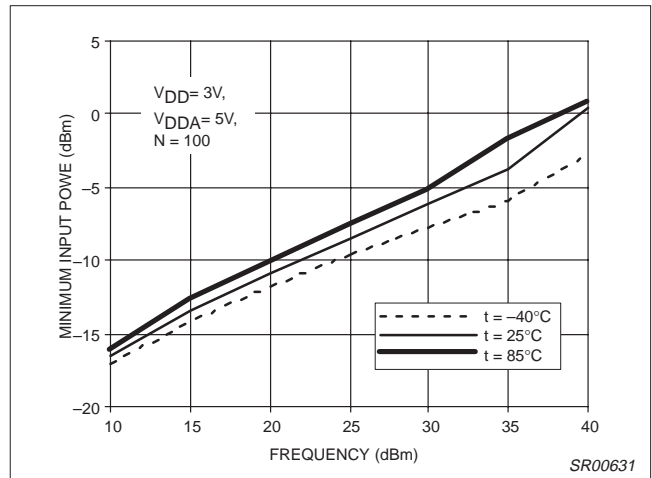

Figure 21. Reference Divider Minimum Input Power vs Frequency and Temperature

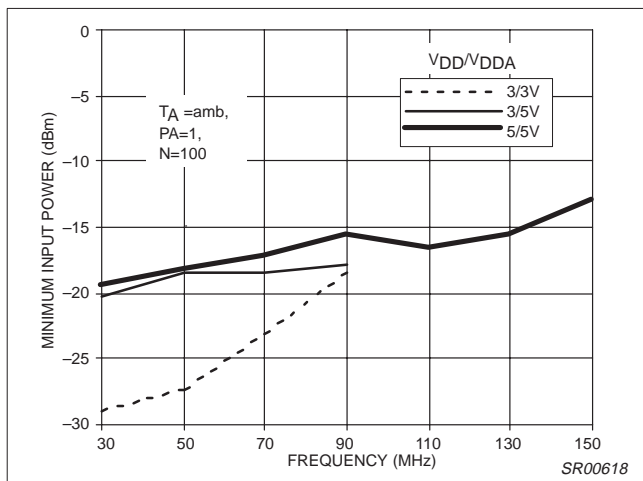

Figure 19. Auxiliary Divider Minimum Input Power vs Frequency and Supply

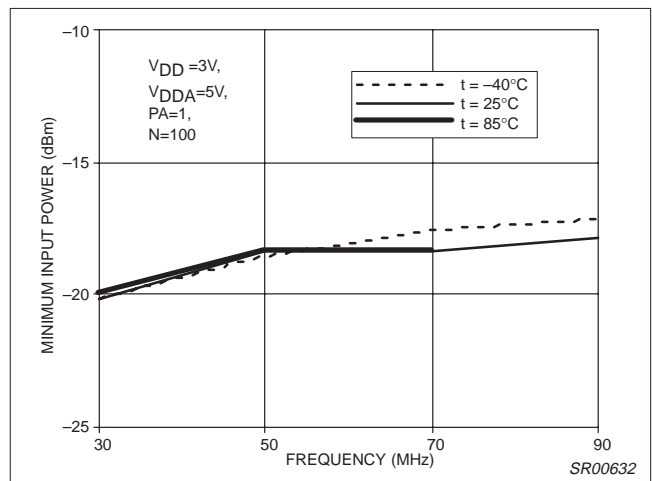

Figure 22. Auxiliary Divider Minimum Input Power vs Frequency and Temperature

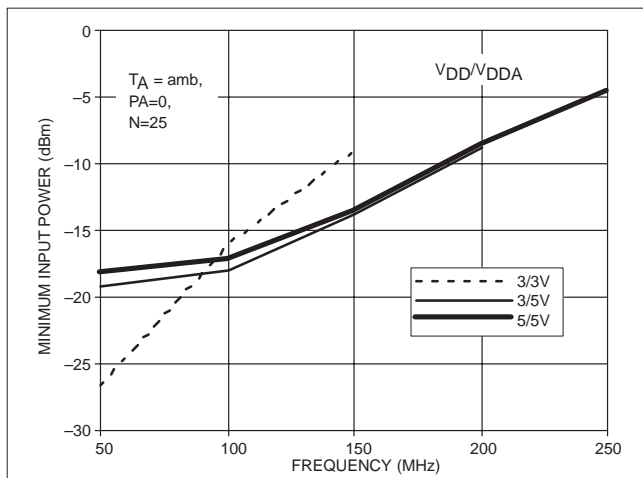

Figure 20. Auxiliary Divider Minimum Input Power vs Frequency and Supply

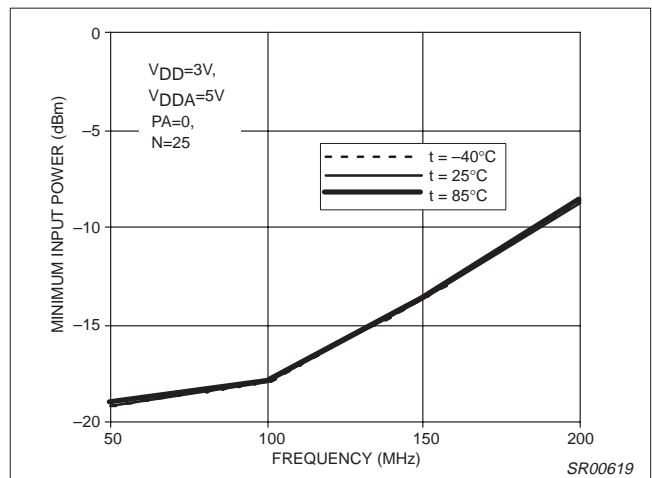

Figure 23. Auxiliary Divider Minimum Input Power vs Frequency and Temperature

1GHz low-voltage Fractional-N synthesizer

SA7025

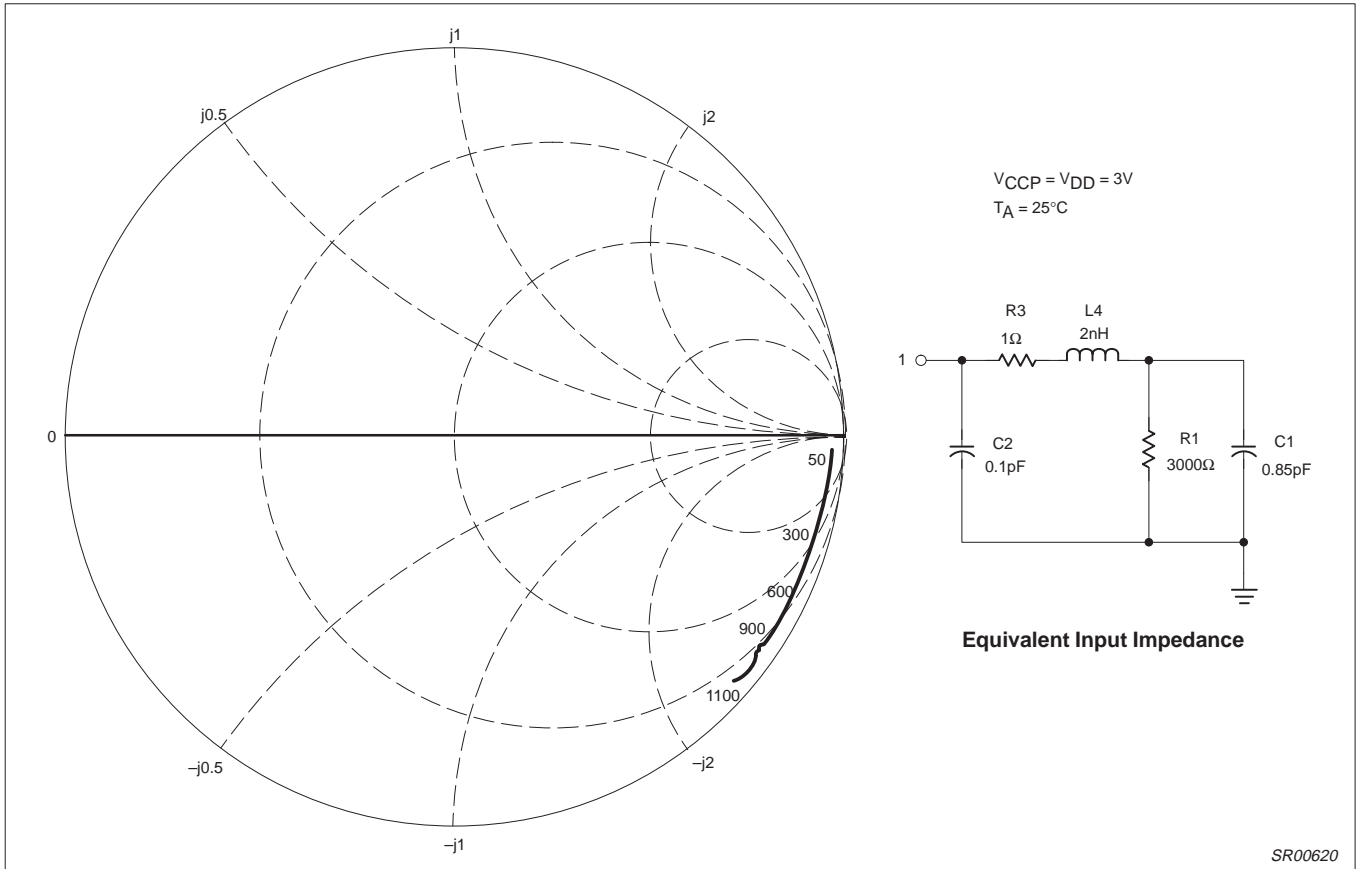
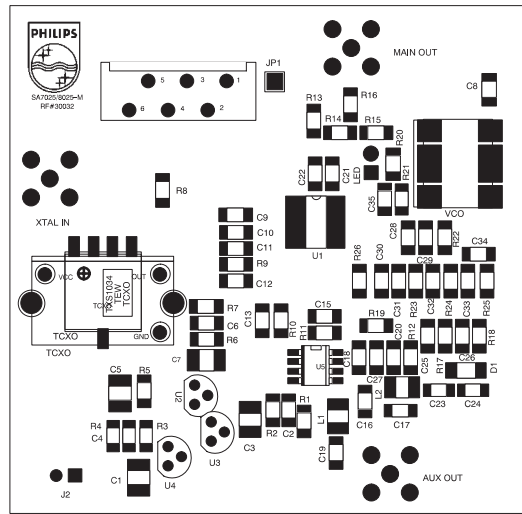

Figure 24. Typical RF_{IN} Input Impedance

1GHz low-voltage Fractional-N synthesizer

SA7025



TOP SILK SCREEN

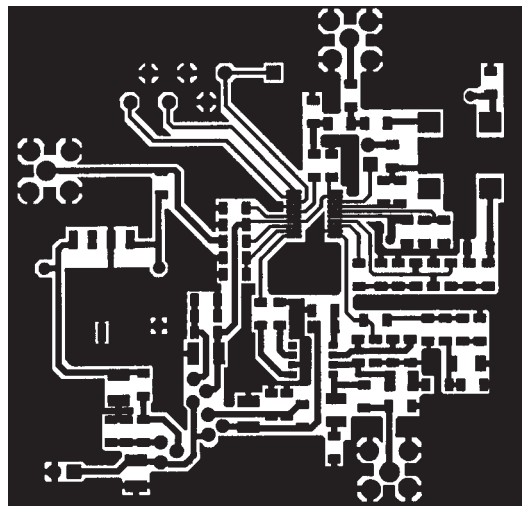

TOP VIEW

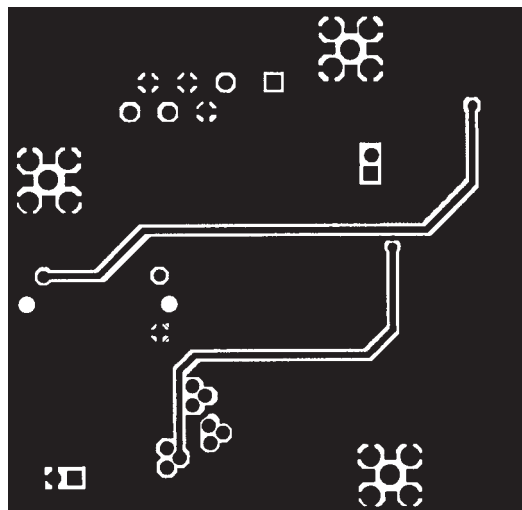

BOTTOM VIEW

SR00621

Figure 25. SA7025DK Demoboard Layout (NOT ACTUAL SIZE)

1GHz low-voltage Fractional-N synthesizer

SA7025

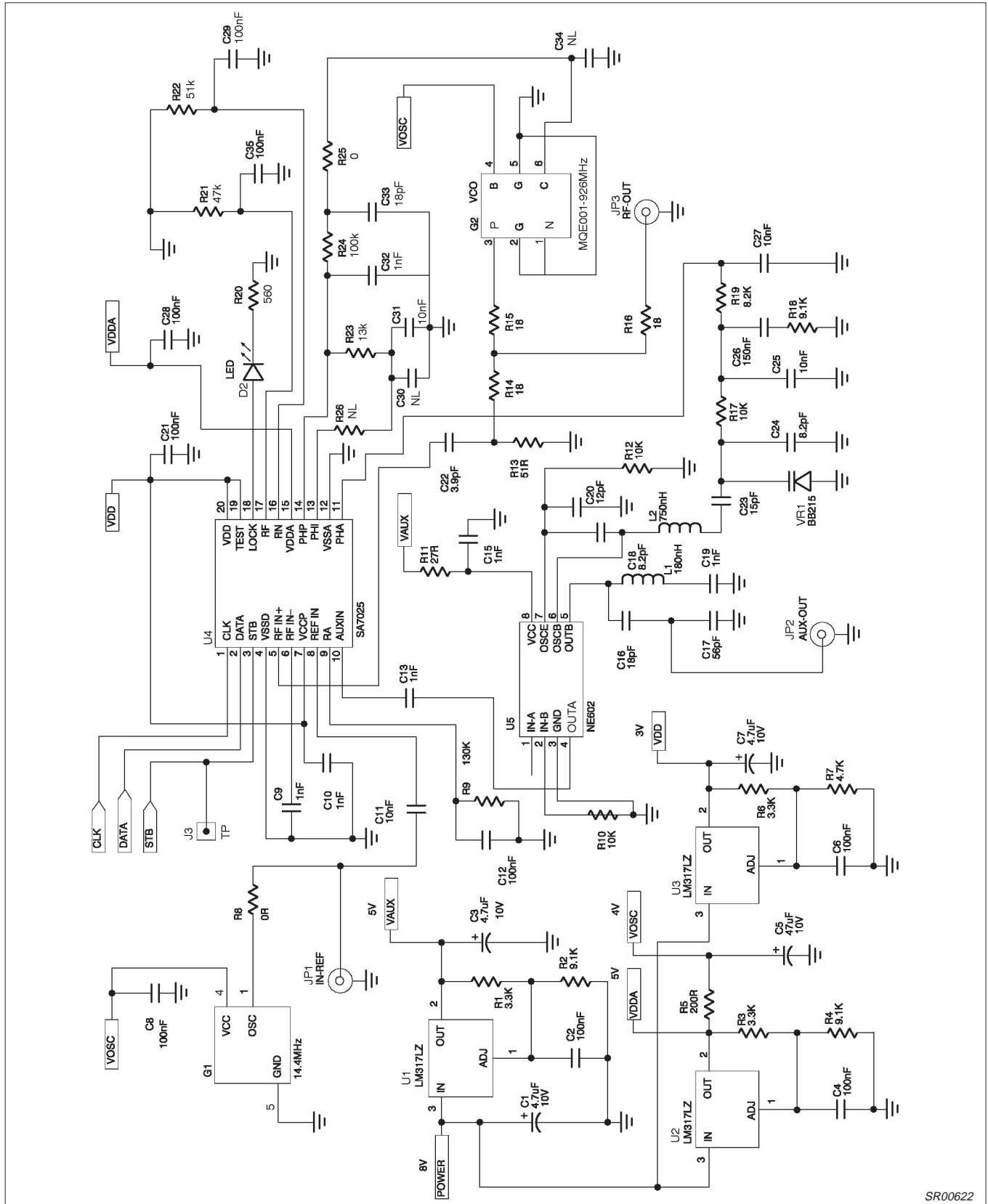

Figure 26. SA7025DK Application Circuit

SR00622

1GHz low-voltage Fractional-N synthesizer

SA7025

SSOP20: plastic shrink small outline package; 20 leads; body width 4.4 mm

SOT266-1

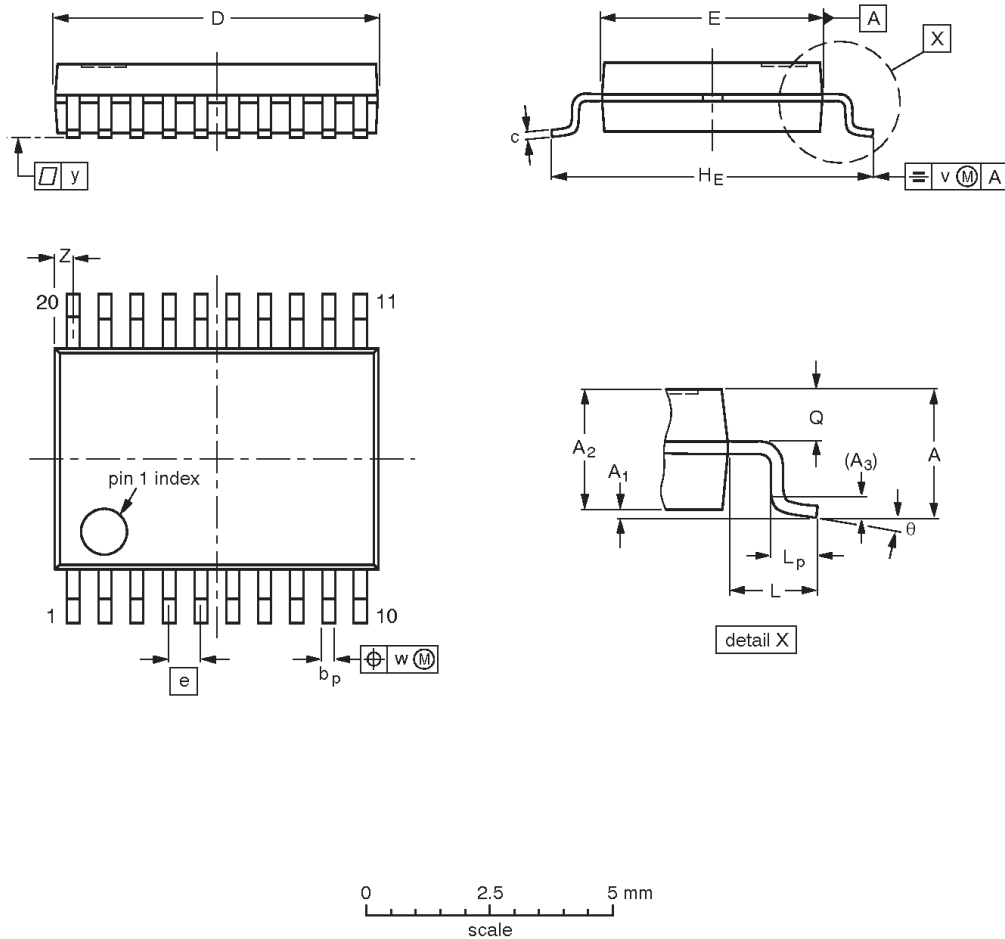

DIMENSIONS (mm are the original dimensions)

UNIT	A max.	A ₁	A ₂	A ₃	b _p	c	D ⁽¹⁾	E ⁽¹⁾	e	H _E	L	L _p	Q	v	w	y	Z ⁽¹⁾	θ
mm	1.5	0.15 0	1.4 1.2	0.25	0.32 0.20	0.20 0.13	6.6 6.4	4.5 4.3	0.65	6.6 6.2	1.0	0.75 0.45	0.65 0.45	0.2	0.13	0.1	0.48 0.18	10° 0°

Note

1. Plastic or metal protrusions of 0.20 mm maximum per side are not included.

OUTLINE VERSION	REFERENCES				EUROPEAN PROJECTION	ISSUE DATE
	IEC	JEDEC	EIAJ			
SOT266-1						90-04-05 95-02-25

Low-voltage 1GHz fractional-N synthesizer

SA7025

DEFINITIONS

Data Sheet Identification	Product Status	Definition
<i>Objective Specification</i>	Formative or in Design	This data sheet contains the design target or goal specifications for product development. Specifications may change in any manner without notice.
<i>Preliminary Specification</i>	Preproduction Product	This data sheet contains preliminary data, and supplementary data will be published at a later date. Philips Semiconductors reserves the right to make changes at any time without notice in order to improve design and supply the best possible product.
<i>Product Specification</i>	Full Production	This data sheet contains Final Specifications. Philips Semiconductors reserves the right to make changes at any time without notice, in order to improve design and supply the best possible product.

Philips Semiconductors and Philips Electronics North America Corporation reserve the right to make changes, without notice, in the products, including circuits, standard cells, and/or software, described or contained herein in order to improve design and/or performance. Philips Semiconductors assumes no responsibility or liability for the use of any of these products, conveys no license or title under any patent, copyright, or mask work right to these products, and makes no representations or warranties that these products are free from patent, copyright, or mask work right infringement, unless otherwise specified. Applications that are described herein for any of these products are for illustrative purposes only. Philips Semiconductors makes no representation or warranty that such applications will be suitable for the specified use without further testing or modification.

LIFE SUPPORT APPLICATIONS

Philips Semiconductors and Philips Electronics North America Corporation Products are not designed for use in life support appliances, devices, or systems where malfunction of a Philips Semiconductors and Philips Electronics North America Corporation Product can reasonably be expected to result in a personal injury. Philips Semiconductors and Philips Electronics North America Corporation customers using or selling Philips Semiconductors and Philips Electronics North America Corporation Products for use in such applications do so at their own risk and agree to fully indemnify Philips Semiconductors and Philips Electronics North America Corporation for any damages resulting from such improper use or sale.

Philips Semiconductors
811 East Arques Avenue
P.O. Box 3409
Sunnyvale, California 94088-3409
Telephone 800-234-7381

Philips Semiconductors and Philips Electronics North America Corporation register eligible circuits under the Semiconductor Chip Protection Act.
 © Copyright Philips Electronics North America Corporation 1996
 All rights reserved. Printed in U.S.A.

print code

Document order number:

Let's make things better.