

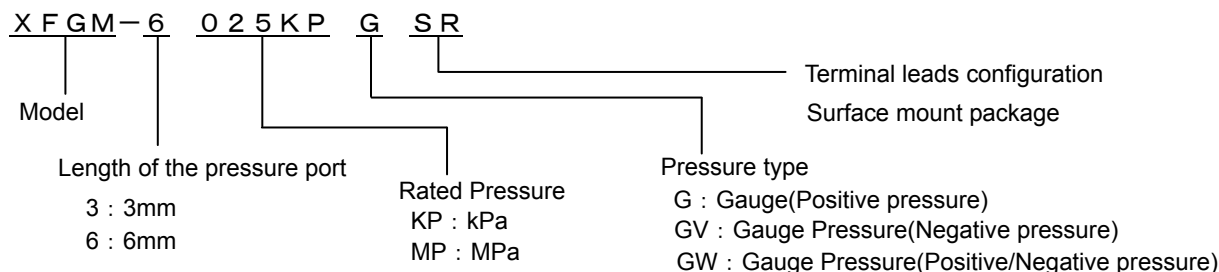

■Features

- On-chip amplification and temperature compensations
- Pre-calibration of offset voltage and span
- Surface mount package

■Ordering Information

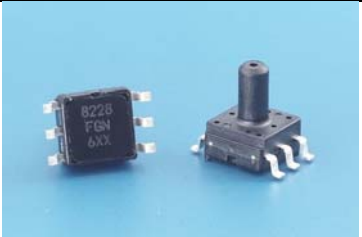

	Weight (grams)		Weight (grams)
	0.3		0.35

Measurable pressure range(kPa)	Part number	
	3mm pressure port	6mm pressure port
-100 to 100	XFGM-3100KPGWSR	XFGM-6100KPGWSR
0 to -100	XFGM-3100KPGVSR	XFGM-6100KPGVSR
0 to 25	XFGM-3025KPGSR	XFGM-6025KPGSR
0 to 50	XFGM-3050KPGSR	XFGM-6050KPGSR
0 to 100	XFGM-3100KPGSR	XFGM-6100KPGSR
0 to 200	XFGM-3200KPGSR	XFGM-6200KPGSR
0 to 1000	XFGM-3001MPGSR	XFGM-6001MPGSR

RoHS compliance

■Specifications

Model	100KPGW	100KPGV	025KPG	050KPG	100KPG	200KPG	001MPG	Unit
Recommended operating conditions								
Pressure type	Gauge pressure							-
Rated pressure	+/-100	-100	25	50	100	200	1000	kPa
Measurable pressure range	-100 to 100	0 to -100	0 to 25	0 to 50	0 to 100	0 to 200	0 to 1000	kPa
Temperature range	0 to 85							deg.C
Pressure media	Non-corrosive gases only (No liquid)							-
Supply voltage(constant)	5+/-0.25							VDC
Absolute maximum rating								
Maximum load pressure	Twice of rated pressure						1.5 times of rating pressure	-
Maximum excitation voltage	8							VDC
Operating temperature	-40 to 125							deg.C
Storage temperature	-40 to 125							deg.C
Operating humidity	30 to 80 (Non dew condition)							%RH
Electrical characteristics (Excitation voltage Vcc=5.0V constant , ambient temperature Ta=25deg.C)								
Power consumption	10mA max.							mA
Output impedance	10Ω max.							Ω
Source current	0.2mA max.							mA
Sink current	2mA max.							mA
Response time	2 (for the reference)							msec.
Output span voltage	4.5							V
Offset voltage *1	*2	*3	0.2+/-0.1125 (at 0 kPa)				V	
Output voltage at full scale *1	*4	*5	4.7+/-0.1125 (at rated pressure)				V	
Accuracy *1	+/-2.5							%FS/0-85deg.C

*1 Excluding input voltage error. 0-85deg.C

*2 0.2+/-0.1125V(at -100kPa) *3 0.2+/-0.1125V(at 0kPa)

*4 4.7+/-0.1125V(at +100kPa) *5 4.7+/-0.1125V(at -100kPa)

■ Outline dimensions ■

XFGM-3

unit : mm

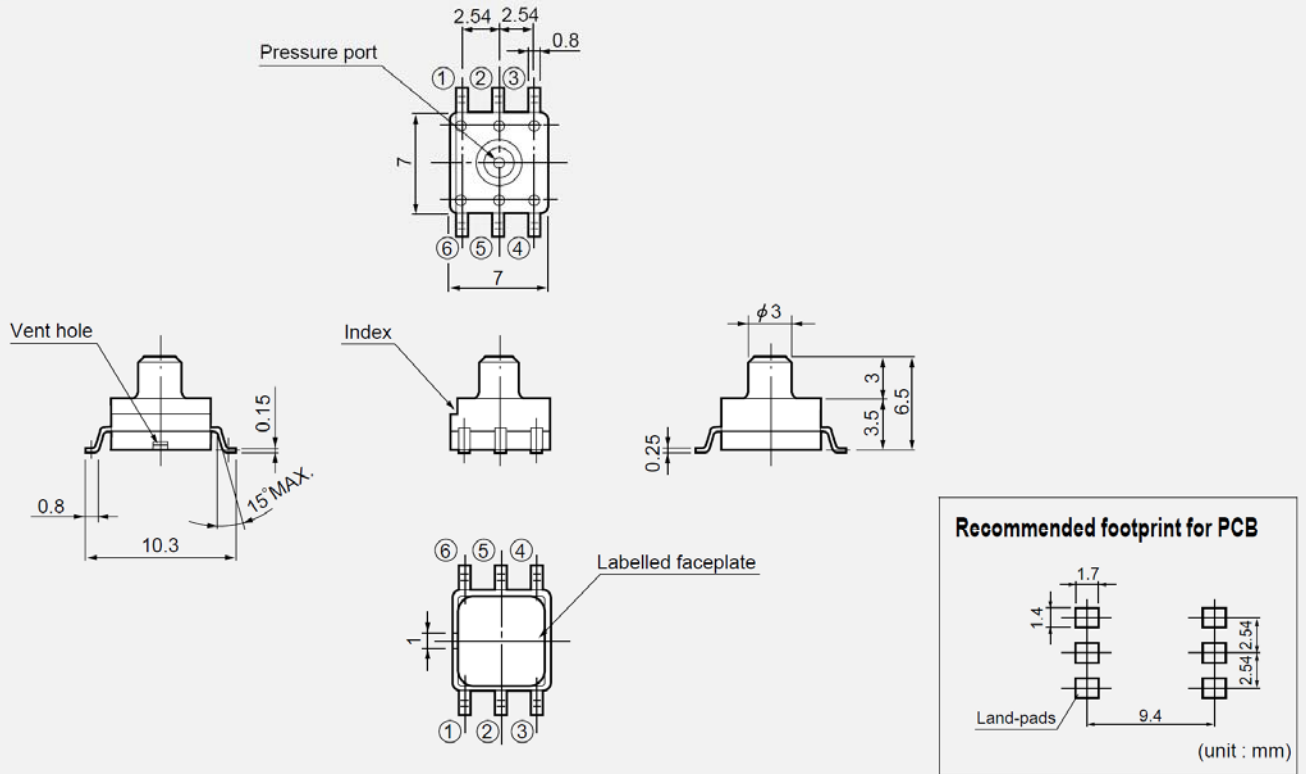

XFGM-6

unit : mm

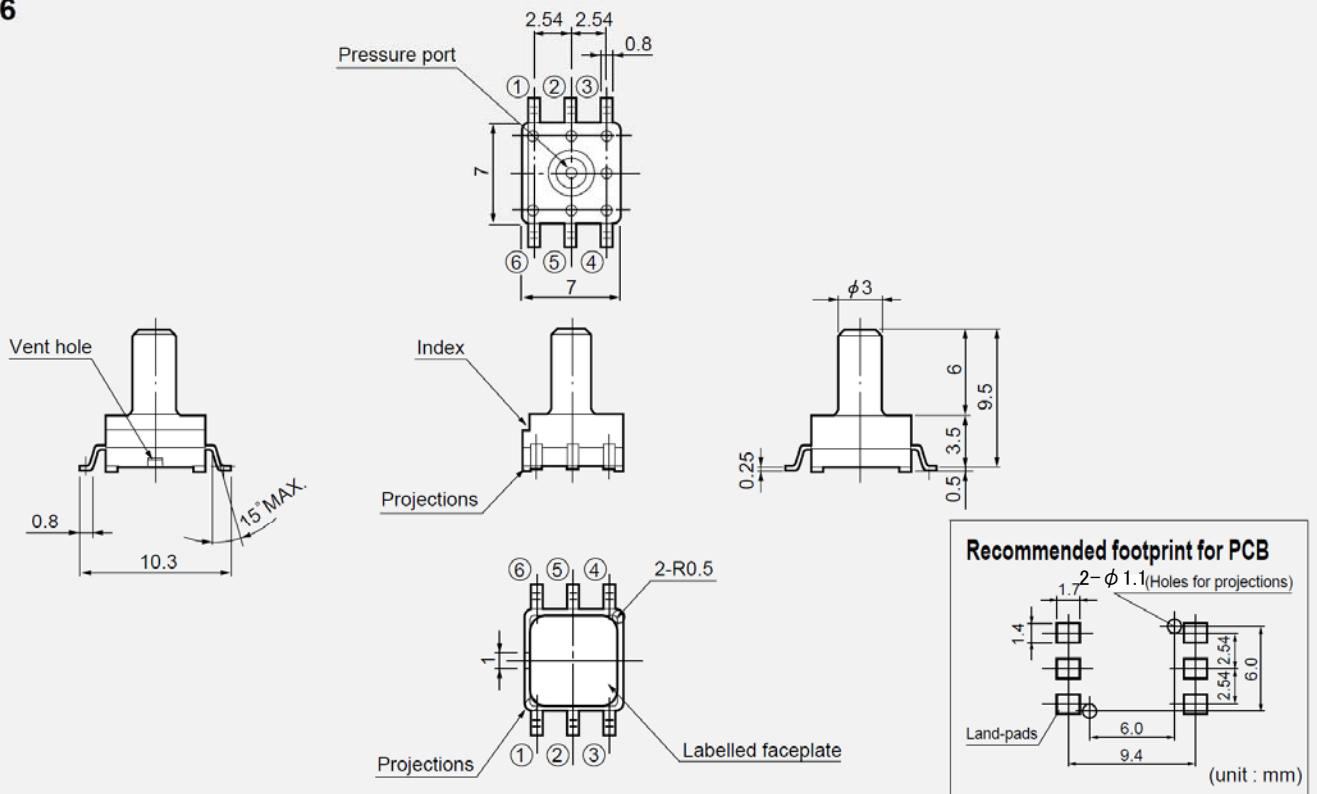

■Connection diagram■

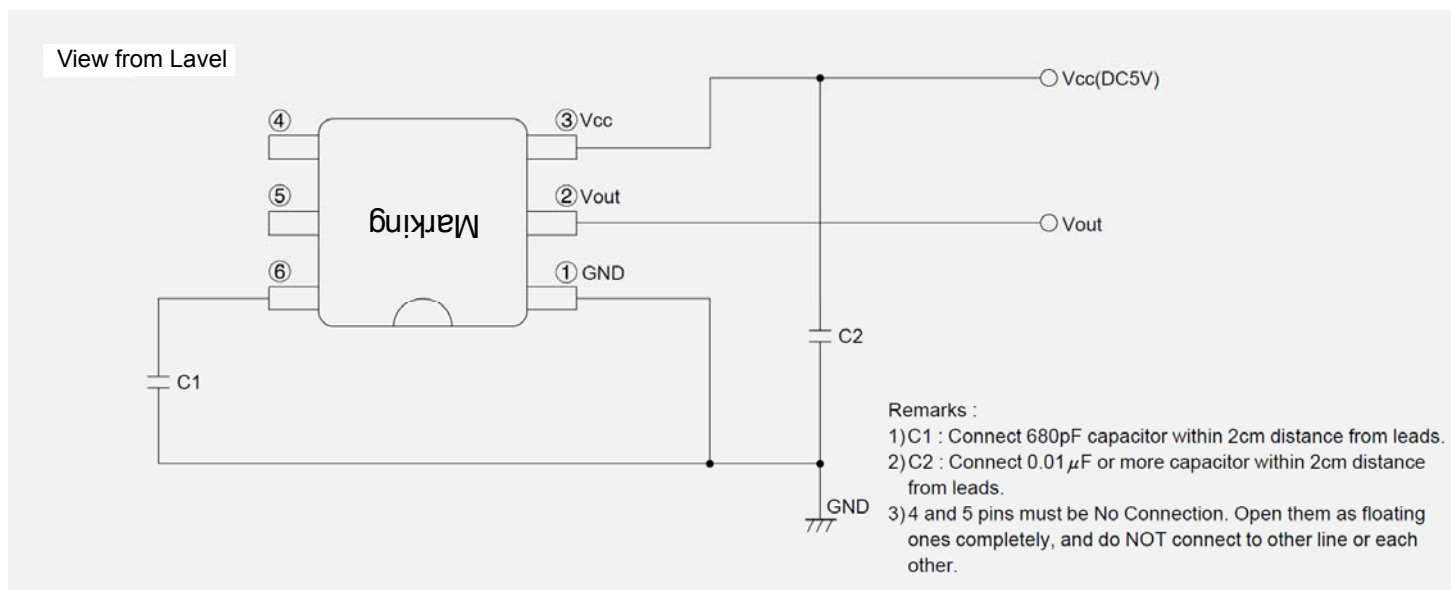

■Transfer Function■

$$V_{out} = V_s \times (P \times \alpha + \beta) \pm (\text{Pressure Error} \times \text{Temperature Error Multiplier} \times \alpha \times V_s)$$

$$V_s = V_{cc} = 5.0V$$

$$P = \text{Input pressure (kPa)}$$

Model		Measurable pressure range(kPa)	α	β	Pressure Error (kPa)
XFGM-3100KPGWSR	XFGM-6100KPGWSR	-100 to 100	0.0045	0.49	5
XFGM-3100KPGVSR	XFGM-6100KPGVSR	0 to -100	-0.009	0.04	2.5
XFGM-3025KPGSR	XFGM-6025KPGSR	0 to 25	0.036	0.04	0.625
XFGM-3050KPGSR	XFGM-6050KPGSR	0 to 50	0.018	0.04	1.25
XFGM-3100KPGSR	XFGM-6100KPGSR	0 to 100	0.009	0.04	2.5
XFGM-3200KPGSR	XFGM-6200KPGSR	0 to 200	0.0045	0.04	5
XFGM-3001MPGSR	XFGM-6001MPGSR	0 to 1000	0.0009	0.04	25

Temperature Error Multiplier

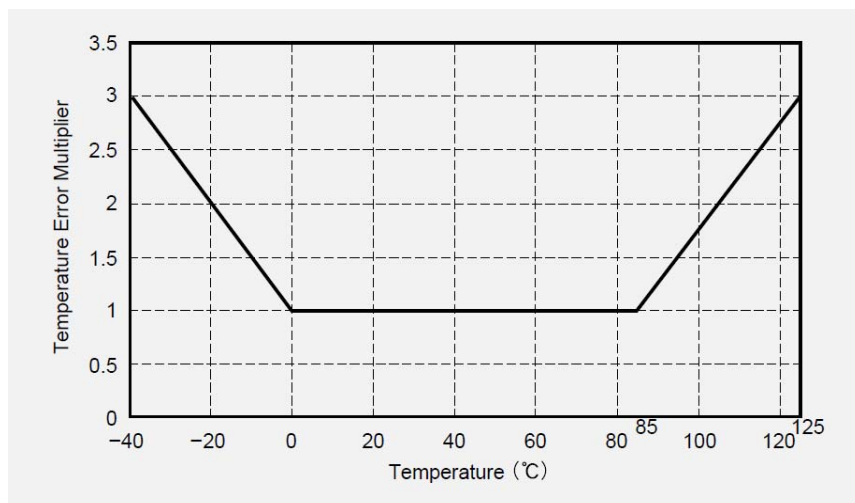

■Output characteristics■

XFGM-3100KPGVSR	XFGM-6100KPGVSR
XFGM-3025KPGSR	XFGM-6025KPGSR
XFGM-3050KPGSR	XFGM-6050KPGSR
XFGM-3100KPGSR	XFGM-6100KPGSR
XFGM-3200KPGSR	XFGM-6200KPGSR
XFGM-3001MPGSR	XFGM-6001MPGSR

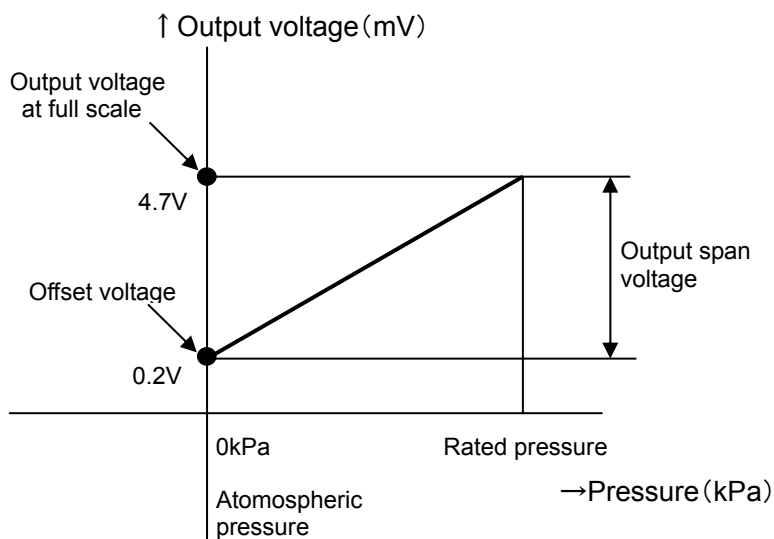

XFGM-3100KPGWSR	XFGM-6100KPGWSR
-----------------	-----------------

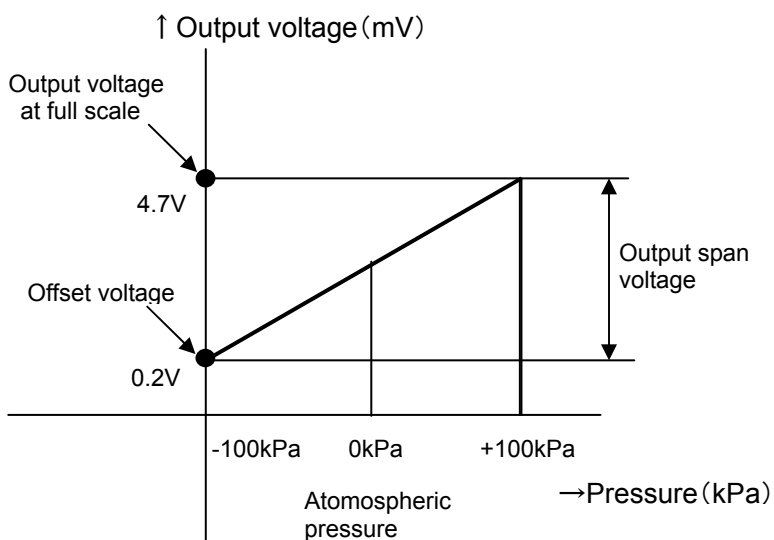

Note ; Please read instruction “Notes” before using the sensor.
Fujikura reserves the right to change specifications without notice.

Please keep the sensors sealed using static shielding bags on storage. The pins of the sensor are plated by Ag. If the sensors expose to an atmosphere, the pins will be black by sulfuration.

Please set Zero-calibration function up your products. The offset voltage may be shifted some mechanical stress such as mounting, installation and etc. over longtime using.

Reflow Soldering process recommendation profile

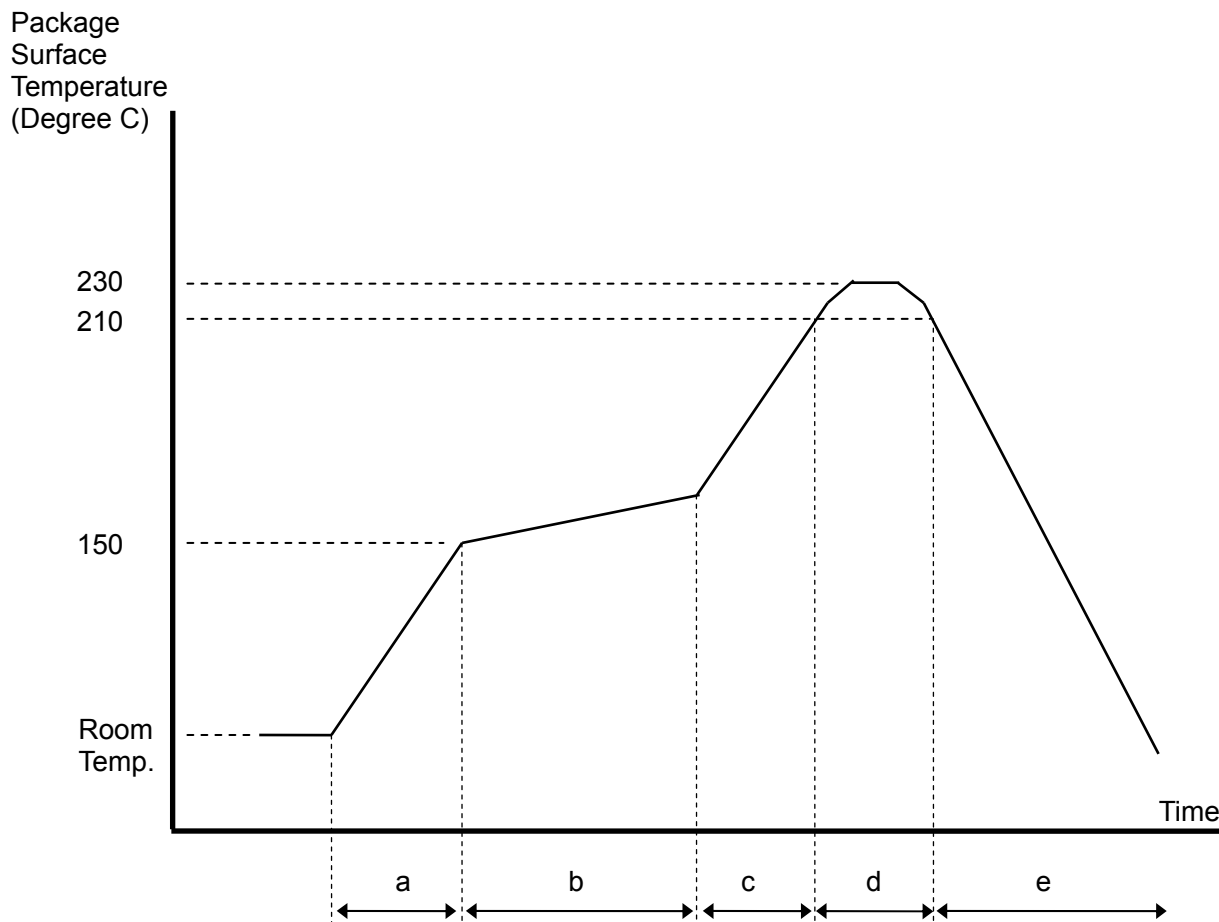

a: Ramp up rate	1 or 2 deg.C/sec.
b: Pre-heating	150 to 180 deg.C, within 60 to 120sec.
c: Ramp up rate	1 to 2 deg.C/sec.
d: Heating	max. 230 deg.C, max. 10sec. 210 deg.C, within 30sec.
e: Ramp down rate	1 or 2 deg.C/sec.

- Note ;
- 1) Temperature means Surface temperature of the sensor package.
 - 2) Reflow process max. 2 times.
 - 3) Do not wash the sensor.
 - 4) Do not put the solder and flux on the sensor package.

If you have any questions regarding technical issues or specifications, please contact us.
 Fujikura Ltd. Sensor Department 5-1 Kiba 1-chome, Koto-ku, Tokyo 135-8512, Japan
 Phone +81-(0)3-5606-1072
 E-mail : sensor@fujikura.co.jp