

RECOMMENDED P.C.B. LAYOUT  
TOP VIEW(TOLERANCE ±0.05)

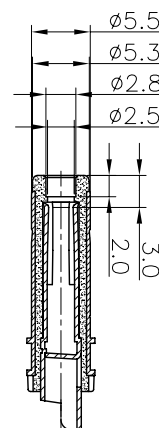

Ø5.50 PLUG TYPE(2DP-G213-BG6)  
RATING: DC 30V 10A 44uF

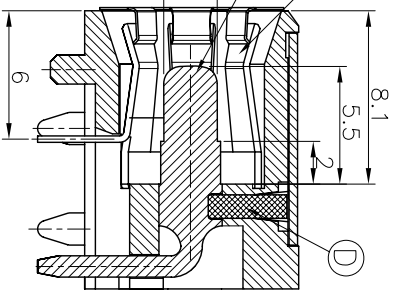
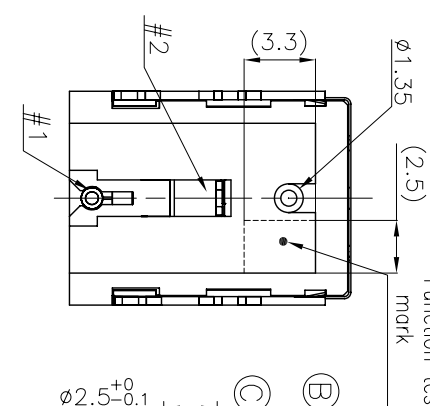
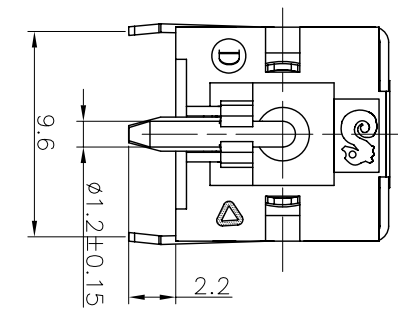
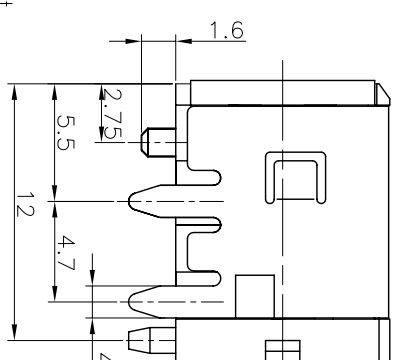
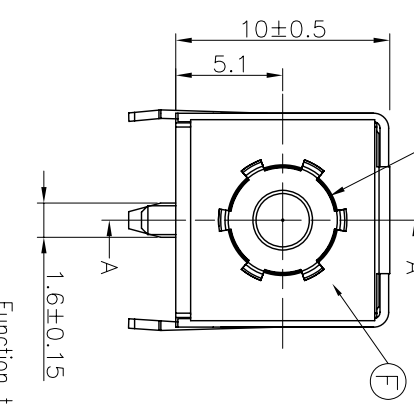
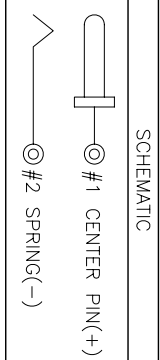

REV.	ECN NO. OR DESCRIPTION	REVISED	DATE
G	ECN NO.S110850	SPRING	2011.08.26
H	ECN NO.S110921	SPRING	2011.09.23
I	ECN NO.S120524	Angus	2012.05.31

- SPECIFICATIONS:
- RATING: DC 30V 10A
  - INSERTION FORCE: 3.0kg MAX.  
WITHDRAWAL FORCE: 1.0kg~3.0kg
  - INSULATION RESISTANCE BETWEEN ANY ADJACENT TERMINALS SHALL NOT BE LESS THAN 100 MEGOHMS BY 500 VOLTS MEGGER.
  - JACK SHALL WITHSTAND 250 VOLTS BETWEEN ANY ADJACENT TERMINAL FOR ONE MINUTE.
  - CONTACT RESISTANCE SHALL NOT EXCEED 30mΩ
  - JACK SHALL WITHSTAND 5,000 CYCLES OF INSERTION AND WITHDRAWAL WITH TESTING PLUG AND CONTACT RESISTANCE SHALL NOT EXCEED 50mΩ
  - MEASURING CONDITION:  
TEMPERATURE: FROM 5°C TO 35°C.  
RELATIVE HUMIDITY: FROM 40% TO 85%.
  - ENVIRONMENTAL SPECIFICATIONS:  
8.1 HUMIDITY TEST: HUMIDITY 90% TO 95% TEMPERATURE 40°C ±2°C FOR 96 HOURS.
  - HEAT TEST: TEMPERATURE 70°C ± 2°C (HUMIDITY BELOW 50%) FOR 96 HOURS.
  - COLD TEST: TEMPERATURE -40°C ± 2°C FOR 96 HOURS.
  - MATING PLUG : SINGATRON'S P/N : 2DP-G213-BG6(PLUG SET)
  - PACKAGING: TAPE & REEL
  - PRINTED DATE CODE:"YMMDD" \*ON TOP OF CONNECTOR.
  - RATING:30V 10A 44uF DEPEND ON MATING PLUG DETAIL TYPE
  - TO CONFORM TO SINGATRON HAZARDOUS SUBSTANCE FREE SPEC.
  - GREEN PRODUCT IDENTIFICATION MARK ON JACK: G.P. PASS
  - GREEN PRODUCT IDENTIFICATION LABEL ON PACKAGING:  
16.FOR REFLOW SOLDERING LEAD FREE PROCESS.

F	GROUND	1	STAINLESS STEEL 0.15t	N/A
E	SHELL	1	SPPC-SD 0.4t	NI 60u" Min.
D	STOPPER	1	HIGH TEMP.THERMOPLASTIC U94w-0	BLACK
C	PIN	1	HB159-1.5B	GOLD FLASH OVER Ni50u"
B	SPRING	1	COPPER ALLOY 0.3t	Sn 60u"Min.,Ni 60u"Min.
A	BODY	1	HIGH TEMP.THERMOPLASTIC U94w-0	GRAY
NO	DESCRIPTION		MATERIAL	PLATING & COLOR
UNLESS OTHERWISE SPECIFIED TOLERANCES				
Singatron Enterprise Co., Ltd. 信音企業股份有限公司				
TITLE: DC POWER JACK				
DMW	Angus	PART NO.	2DC-G213-B48	
CHKD	Tom	SCALE:4:1	UNIT:	mm
APVD	Tony	SIZE: A3	SHEET:1 OF 1	REV:1
CUSTOMER COPY				