

Marvell Link Street-88E6390X

11 Port Ethernet Switch with Eight 10/100/1000Mbps PHYs
and Two XAU1/RXAUI/2500Base-X Interfaces

PRODUCT OVERVIEW

The Marvell® Link Street®-88E6390X device is a single-chip, 11-Port Ethernet Switch with eight integrated 10/100/1000Mbps Ethernet transceivers and two high speed SerDes interfaces supporting 10Gbps XAU1 and RXAU1, 2500-BaseX, 1000Base-X, and SGMII. The device also includes an integrated 200MHz microprocessor to enable smart or lightly managed switches without the need of an external CPU.

The 88E6390X provides advanced Quality of Service (QoS) features with 8 egress queues. The high performance switch fabric provides line rate switching on all ports simultaneously while providing advanced switch functionality. The device includes a 256 entry TCAM to enable flexible switch policing, including Access Control Lists (ACLs) and Policy Control Lists (PCLs). The 88E6390X also supports the latest IEEE 802.1 Audio Video Bridging (AVB) and Time Sensitive Networking (TSN) standards. These new standards overcome the latency and bandwidth limitations of Ethernet to allow for the efficient transmission of real-time content for home, commercial, and industrial applications. These devices use the AVB/TSN technologies to identify and reserve the network resources for AVB/TSN traffic streams and supports precise isochronous streaming capability for reliable and quality audio/video transmission over Ethernet for today's real-time, high definition information and entertainment options. The AVB/TSN protocols enable timing sensitive streams (such as digital video, audio, or industrial control traffic) to be sent over the Ethernet network with low latency and robust QoS guarantees.

BLOCK DIAGRAM

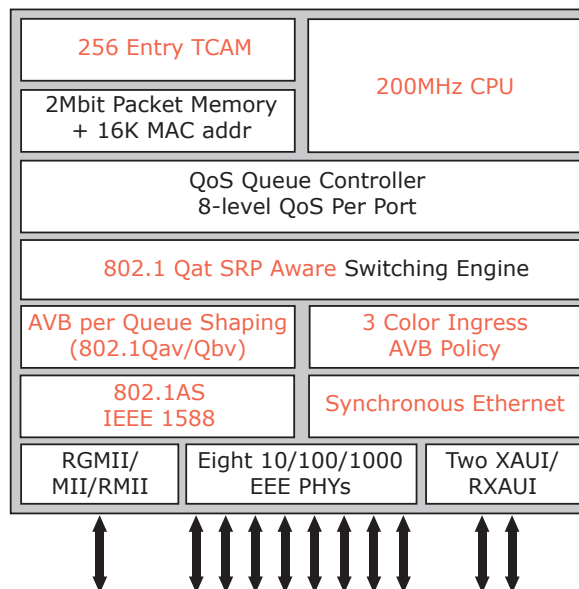

Fig 1. Marvell Link Street-88E6390X Block Diagram

FEATURES AND BENEFITS

SPECIAL FEATURES	BENEFITS
<ul style="list-style-type: none"> High performance, non-blocking, 11-port Ethernet Switch fabricated on 28nm process, integrating: <ul style="list-style-type: none"> Eight 10/100/1000Mbps PHYs with Advanced Virtual Cable Tester (VCT) diagnostic features Two 10Gbps XAUI/RXAUI Interfaces <ul style="list-style-type: none"> 2.5Gbps/1Gbps also supported Packaged in 361-BGA (17x17mm) 	<ul style="list-style-type: none"> Provides a complete Gigabit Ethernet switching solution for SOHO and SMB 8 port switches and routers. The 10Gbps interfaces provide non-blocking uplink to cascade to higher port count 16 and 24 port switches Energy Efficient Ethernet PHYs reduce power consumption while VCT provides qualitative cable-plant diagnosis, lowering Opex
<ul style="list-style-type: none"> Integrated 200MHz microprocessor <ul style="list-style-type: none"> Includes 60Kbytes integrated memory 	<ul style="list-style-type: none"> Enables managed switch designs with the addition of a low cost EEPROM
<ul style="list-style-type: none"> Supports IEEE 1588v2 one-step PTP Cut-through switch fabric for low latency applications Synchronous Ethernet for 1000Base-T or 100Base-TX 	<ul style="list-style-type: none"> Advanced timing features support clock synchronization and reduced latency for time sensitive content
<ul style="list-style-type: none"> 256 Entry TCAM for Deep Packet Inspection <ul style="list-style-type: none"> Looks up to 48 or 96 bytes deep into a frame 	<ul style="list-style-type: none"> Enables intelligent switching and policing of packets by looking beyond Layer 2 packet information
<ul style="list-style-type: none"> Supports 802.1 Audio Video Bridging (AVB) and Time Sensitive Networking (TSN) Standards 	<ul style="list-style-type: none"> Provides the latency, bandwidth and Quality of Service guarantees required to deliver today's multimedia entertainment and information over the Ethernet network.
<ul style="list-style-type: none"> Quality of Service (QoS) support with 8 traffic classes <ul style="list-style-type: none"> QoS determined by 802.1p, port, Source or Destination MAC address, 802.1Q VLAN ID, Frame Type (e.g., ARP, Ethertype, etc.), IPv4 Type of Service (TOS), Differentiated Service (DiffServ), or IPv6 Traffic Class 	<ul style="list-style-type: none"> Best in Class QoS features enable prioritization of all types of traffic (e.g. video, voice, data) to ensure efficient use of network bandwidth. Provides guaranteed delivery of time-sensitive Audio/Video content when used in conjunction with AVB/TSN standards.
<ul style="list-style-type: none"> Advanced Features <ul style="list-style-type: none"> High performance switch fabric with support for up to 16K MAC addresses Supports 10KByte Jumbo Frames Best in class per port ingress rate limiting and broadcast storm prevention (5 rate limiters per port) Per port rate shaping 802.1Qbb Priority Flow Control 	<ul style="list-style-type: none"> Provides high-speed, non-blocking, Gigabit performance for cost sensitive consumer applications. Advanced rate limiting, egress shaping and storm prevention improve traffic management and network performance, and reduce unwanted flooding of ports.
<ul style="list-style-type: none"> Management and Security <ul style="list-style-type: none"> Supports 4096 802.1Q VLANs Supports 802.1D/s/w Spanning Tree Protocols IPv4 IGMP and IPv6 MLD snooping 802.1x MAC Authentication Remote (In-band) Management 	<ul style="list-style-type: none"> Built-in network management and security features, support fully managed switches and truly isolated WAN vs. LAN firewall applications. The device supports 4096 802.1Q VLAN IDs, which can be enabled on a per port basis. Three levels of 802.1Q security is supported with error framed trapping and logging

APPLICATIONS

The Marvell Link Street-88E6390X is the industry's first true SOHO Ethernet switch chip to support 10Gbps interfaces. The addition of 10Gbps interfaces provides flexibility to support many different non-blocking switch configurations.

- Unmanaged/Managed 8, 16, and 24-port Gigabit Switches Scalable architecture enables support for non-blocking high performance Gigabit switches with 10 Gigabit uplinks
- Smart and Lightly Managed Switches— Integrated microprocessor enables lightly managed switches with the addition of an external EEPROM
- Industrial Switches – Synchronous Ethernet, IEEE 1588v2, and 802.1 TSN support enable timing critical industrial networks

THE MARVELL ADVANTAGE: Marvell chipsets come with complete reference designs which include board layout designs, software, manufacturing diagnostic tools, documentation, and other items to assist customers with product evaluation and production. Marvell's worldwide field application engineers collaborate closely with end customers to develop and deliver new leading-edge products for quick time-to-market. Marvell utilizes world-leading semiconductor foundry and packaging services to reliably deliver high-volume and low-cost total solutions.

ABOUT MARVELL: Marvell (NASDAQ: MRVL) is a global leader in providing complete silicon solutions enabling the digital connected lifestyle. From mobile communications to storage, cloud infrastructure, Internet of Things (IoT), digital entertainment and in-home content delivery, Marvell's diverse product portfolio aligns with end customers to develop and deliver new leading-edge products for quick time-to-market. At the core of the world's most powerful consumer, network and enterprise systems, Marvell empowers partners and their customers to always stand at the forefront of innovation, performance and mass appeal. By providing people around the world with mobility and ease of access to services adding value to their social, private and work lives, Marvell is committed to enhancing the human experience. As used herein, the term "Marvell" refers to Marvell Technology Group Ltd. and its subsidiaries.

CONTACT US: For additional information, please visit our website at www.marvell.com for a Marvell sales office or representative in your area. Copyright ©2015, Marvell. All rights reserved. Marvell, the Marvell logo and Link Street are registered trademarks of Marvell. All other trademarks are the property of their respective owners.

Marvell Link Street-88E6390X 05/15

