



承 认 书

APPROVAL SHEET

编 号 No.	
日期 Date	

客 户 Customer	
-----------------	--

品 名 Product	Thermal Protector
系 列 Series	KSD02

料号 Part No.	规格描述 Specification	备注 Remark
贝特电子 Betterfuse		
客 户 Customer		

环保特别提示 Special instructions for environmental protection
本产品:

供应商-贝特电子 Supplier-Betterfuse	零件承认章 Approval Signet	客 户 Customer	零件承认章 Approval Signet
制 作 Make			
审 核 Check			
确 认 Approval			

联络 Contact			
业务 Sales	电话 Telephone	手机 Cellphone	邮箱 E-mail
零件承认后敬请回签一份给我司留存, 或将承认后的封面传真(0769-8352 1857)至我司, 谢谢!			



KSD 02/ Thermal Protector

Document Record						
No.	Date	Modified Content	Page	Edition	Prepared/modified by	Checked by
1	2021.01.27	Draft		A/0	J.Q.	Faqing Lin
2						
3						
4						
5						
6						
7						
8						
9						
10						
11						

TABLE OF CONTENTS

1. SCOPE AND DESCRIPTION.....	3
2. GENERAL INFORMATION.....	3
3. AGENCY APPROVALS.....	3
4. PART NUMBERING SYSTEM.....	4
5. STRUCTURE.....	5
6. ELECTRICAL CHARACTERISTICS.....	5
7. TEMPERATURE CHARACTERISTIC.....	6
8. ORDERING INFORMATION.....	6
9. PACKING INFORMATION.....	7
10. APPENDIX.....	7



KSD 02/ Thermal Protector

1. SCOPE AND DESCRIPTION



The product for the KSD02 series thermal protector. Mainly as electrical appliances overheating or over temperature protection function

KSD02 series thermal protector, widely used, mainly used in electric motors, pumps, lamps and lanterns, transformer, fan and related temperature overheat or over temperature protection appliance.

2. GENERAL INFORMATION

General Description

Function: KSD02 thermal protector is through the bimetallic strip feel the change of temperature jump off action, and then cut off the circuit. The circuit of overheat or over temperature protection.

Construction: It is mainly composed of three major components: bimetallic strip action mechanism, the shell and the power cord.





Characteristics:

KSD02 thermal protection appliance inductive temperature sensitive, quick, small volume, easy to install, the advantages of widely used in temperature related instruments, used as the over temperature protection or overheating protection.

Detailed Features

- Operating Temperature: 40°C~150°C
- Tolerance: ±5°C
- Temperature difference between operated and resetable temperature : 15°C~50°C
- Endurance: 10, 000 cycles
- Resistance between contacts <50mΩ
- Hi-pot test: 1500VAC 0.5mA 1min
- Insulation resistance: >5MΩ
- Compression test: the product can withstand 100N static pressure for 1min
- Service environment: it shall not be used in high temperature environment above 170°C for a long time
- The heating rate of operating temperature detection should be controlled 1°C/1min
(1 °C / 1min after the nominal operating temperature decreases by 15 °C)
- The product shall not be immersed in a liquid similar to insulating paint, so as to prevent the liquid from penetrating into the inner cavity and causing no electricity

3. AGENCY APPROVALS

Approval	Certification NO.	Rate Voltage / Ampere	Certification category
	R 50482457	277VAC 2A 10,000 cycle 48VDC 3A 30,000 cycle	Thermostat
	E468091	120V/250VAC 3A 50Hz or 60Hz, DC60V 2A 10,000 cycle	Thermostat
	CQC21002281479	277VAC 2A 50Hz or 60Hz 10,000 cycle 48VDC 3A 30,000 cycle (Plastic shell)	Thermostat
	CQC21002283395	277VAC 2A 50Hz or 60Hz 10,000 cycle 48VDC 3A 30,000 cycle (Metal shell)	Thermostat
CB	CN53164	277VAC 2A 50Hz or 60Hz 10,000 cycle 48VDC 3A 30,000 cycle (Plastic shell)	Thermostat
	CN53163	277VAC 2A 50Hz or 60Hz 10,000 cycle 48VDC 3A 30,000 cycle (Metal shell)	Thermostat
	ZU02109-21002	277VAC 2A 50Hz or 60Hz 10,000 cycle (Plastic shell)	Thermostat
	ZU02109-21001	277VAC 2A 50Hz or 60Hz 10,000 cycle (Metal shell)	Thermostat



KSD 02/ Thermal Protector

4. PART NUMBERING SYSTEM

4.1 Part Number

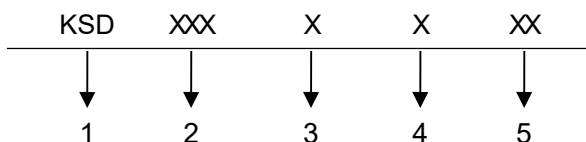

- 1Product Series..... KSD
- 2Operating Temperature..... (See table 4.2)
- 3Casing material..... shell material (See table 4.3)
- 4Type of operating..... 0: Open
1: Close
- 5Supplementary Code..... 00-99
(Or alphanumeric)

Description of body printing mark

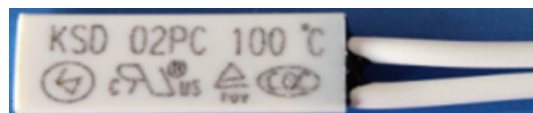

- The first line
- KSD — Name of Product
 - 02 — Type of Product
 - P — Shell Properties of product (P-Plastic M- Metal)
 - C — Type of operating (C- Close O-Open)
 - 100°C — Operating temperature (See table 4.2)
- The second line
- Betterfuse logo
 - UL Safety regulations
 - TUV Safety regulations
 - CQC Safety regulations

4.2 Operating Temperature Table

TEMPERATURE CODE	OPERATING TEMPERATURE
040	40°C
045	45°C
050	50°C
055	55°C
060	60°C
065	65°C
070	70°C
075	75°C
080	80°C
085	85°C
090	90°C
095	95°C
100	100°C
105	105°C
110	110°C
115	115°C
120	120°C
125	125°C
130	130°C
135	135°C
140	140°C
145	145°C
150	150°C

4.3 Casing Material Code Table

CODE	DESCRIPTION
4	Normal metal (13.5X5X2.5)
5	Normal plastic (15X5.4X2.4)
6	Small plastic (12X5.4X2.4)



KSD 02/ Thermal Protector

5. STRUCTURE

KSD02 series (Plastic)

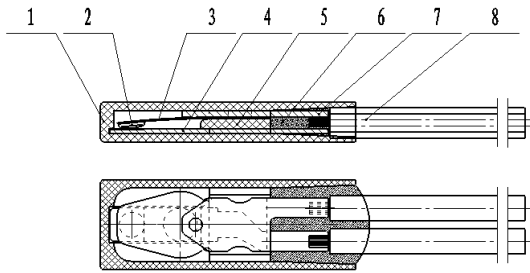

- 1. Plastic casing (PBT-FG30)
- 2. Moving Contact
- 3. Bimetallic strip
- 4. Static contact
- 5. Fixed seat (PBT-FG30)
- 6. Epoxy glue
- Dynamic contact
- 8. Wire

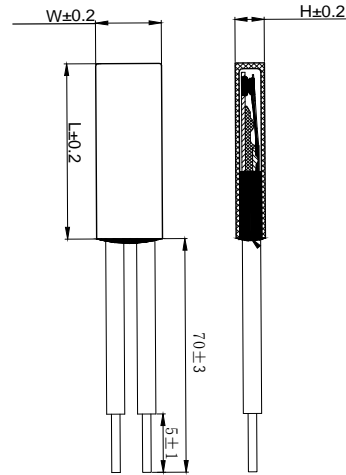

Dimensions (units in mm)

Plastic: LxWxH=15*5.4*2.4(or 12*5.4*2.4)

Metal: LxWxH=13.5*5*2.5

KSD02 series (Metal)

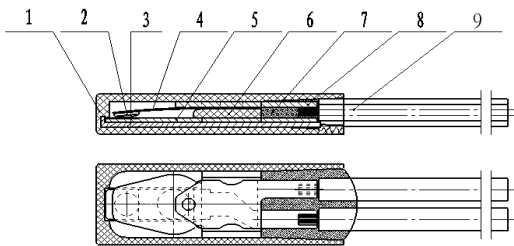

- 1. Metal casing
- 2. Moving contact
- 3. Insulation gasket(PBT-FG30)
- 4. Bimetallic strip
- 5. Static contact
- 6. Fixed seat (PBT-FG30)
- 7. Epoxy glue
- 8. Dynamic contact
- 9. Wire

Parameter:

- 1. Operating: 40°C ~ 150°C
- 2. Tolerance: ±5°C
- 3. Temperature difference between operated and resetable temperature : 15°C ~ 50°C
- 4. Shell size:
 - A、L X W X H=13.5*5*2.5(metal normal size)
 - B、L X W X H=15*5.4*2.4(plastic normal size)
 - C、L X W X H=12*5.4*2.4(plastic small size)
- 5. Shell material: customizable
- 6. Wire length and diameter: customizable
- 7. Reset reference, customizable

6. ELECTRICAL CHARACTERISTICS

Rated parameter: AC277V 2A, DC48V 3A

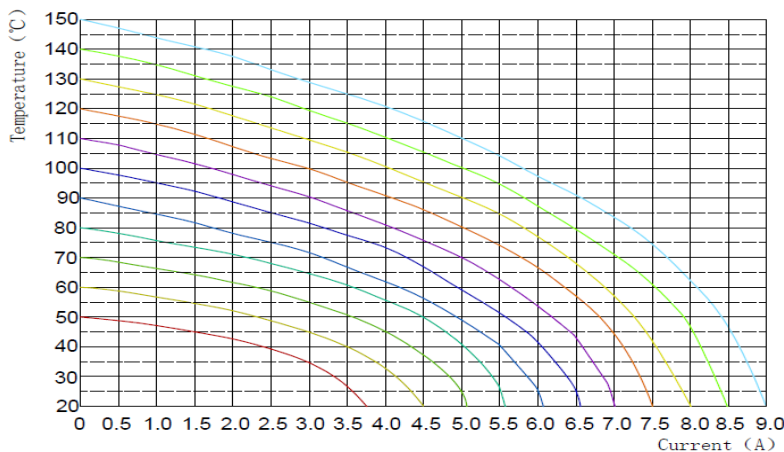

Tripping Temperature vs. Current



KSD 02/ Thermal Protector

7. TEMPERATURE CHARACTERISTIC

TEMPERATURE CHARACTERISTICS

Model	Operating Temperature (°C)	Reset Temperature (°C)	Approval		
			TUV	UL	CQC
			250V	125V	250V
KSD040****	40±5	30	●	●	●
KSD045****	45±5	32	●	●	●
KSD050****	50±5	35	●	●	●
KSD055****	55±5	42±6	●	●	●
KSD060****	60±5	45±8	●	●	●
KSD065****	65±5	48±10	●	●	●
KSD070****	70±5	50±12	●	●	●
KSD075****	75±5	53±14	●	●	●
KSD080****	80±5	55±15	●	●	●
KSD085****	85±5	55±15	●	●	●
KSD090****	90±5	60±15	●	●	●
KSD095****	95±5	65±15	●	●	●
KSD100****	100±5	70±15	●	●	●
KSD105****	105±5	70±15	●	●	●
KSD110****	110±5	75±15	●	●	●
KSD115****	115±5	80±15	●	●	●
KSD120****	120±5	85±15	●	●	●
KSD125****	125±5	85±15	●	●	●
KSD130****	130±5	90±15	●	●	●
KSD135****	135±5	95±15	●	●	●
KSD140****	140±5	100±15	●	●	●
KSD145****	145±5	100±15	●	●	●
KSD150****	150±5	105±15	●	●	●

Note: Reset Temperature only reference

8. ORDERING INFORMATION

The following information are necessary in order to place your order with us correctly:

Model No	Reset Temperature	Supplementary Code	Quantity
KSD02			



KSD 02/ Thermal Protector

9. PACKING INFORMATION

Packing details

Unit:mm

Plastic bag

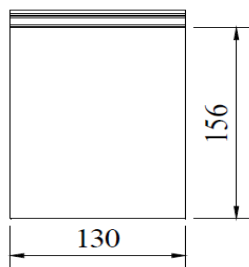

Inner Box

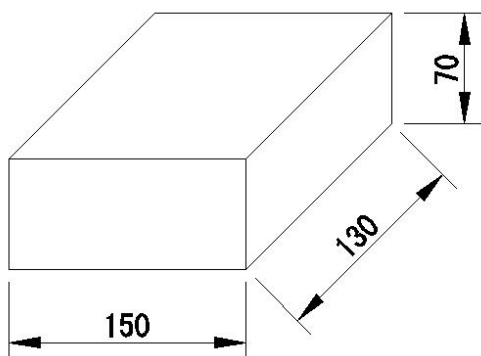

Master Carton

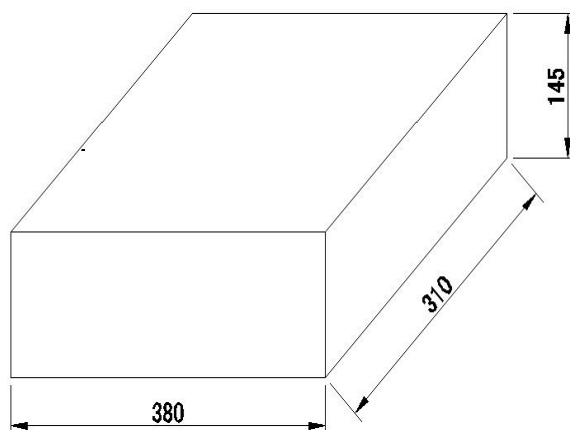

Net Weight (200pcs/bag)	222g	Inner box weight	740g	Master Carton Weight	7.8Kg
Qty per bag	200pcs	Qty per box	600pcs	Qty per carton	6000pcs

DongGuan Better Electronics Technology Co., Ltd.

东莞市贝特电子科技股份有限公司

Tel: +86 769-8323 8731/8323 8732 EXT:807; Fax: +86 769-8352 1857;

website: www.betterfuse.com

Add.: No.7, Sanhe Road, Hengkeng Administrative Zone, Liaobu Town, Dongguan City, Guangdong Province, P. R. C.

东莞市寮步镇横坑三和路7号

Web: www.betterfuse.com

Email: info@betterfuse.com



KSD 02/ Thermal Protector

10. APPENDIX

Precautions for fixing bracket installation

The body of the thermal protector is installed into the bracket with the literal face (non temperature sensing face) downward, which can not be reversed, so as not to affect the temperature sensing effect.

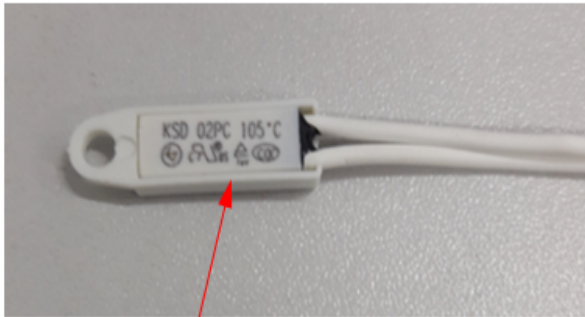

Wrong approach

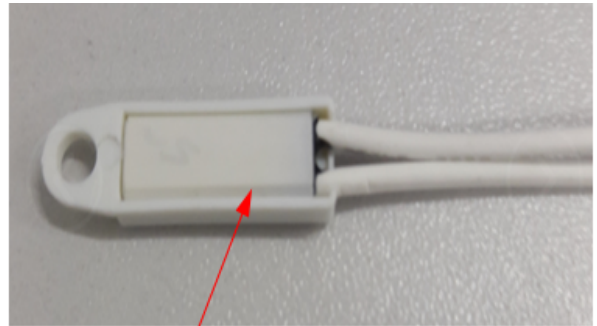

Correct approach

XAPX2.E468091 - Temperature-indicating and -Regulating Equipment - Component

Temperature-indicating and -Regulating Equipment - Component

[See General Information for Temperature-indicating and -Regulating Equipment - Component](#)

DONGGUAN BETTER ELECTRONICS TECHNOLOGY CO LTD

E468091

Rm 601 Of 16 Blk

Xinzhu Yuan No 4 Xinzhu Rd

Songshanlake Hightech Industrial Development Zone

Dongguan, Guangdong 523808 CHINA

Protective control, Thermal cut-out Model(s) ATM-01

Investigated to UL-60730-1

Protective control, Voltage maintained thermal cut-out Model(s) ATM-01P

Investigated to UL-60730-1, UL 60730-2-9

Operating Control, Thermostat Model(s) KSA, KSB, KSD02

Thermostat Model(s) Model KSD05 Series

Protective control, Model(s) Thermal cut-ou ATM-01 Series, Voltage maintained thermal cut-out ATM-01P Series

Model(s) KST-A, KST-B, KST-C, KST-D, KST-R

Marking: Company name and model designation.

[Last Updated](#) on 2020-10-15

The appearance of a company's name or product in this database does not in itself assure that products so identified have been manufactured under UL's Follow-Up Service. Only those products bearing the UL Mark should be considered to be Certified and covered under UL's Follow-Up Service. Always look for the Mark on the product.

UL permits the reproduction of the material contained in the Online Certification Directory subject to the following conditions: 1. The Guide Information, Assemblies, Constructions, Designs, Systems, and/or Certifications (files) must be presented in their entirety and in a non-misleading manner, without any manipulation of the data (or drawings). 2. The statement "Reprinted from the Online Certifications Directory with permission from UL" must appear adjacent to the extracted material. In addition, the reprinted material must include a copyright notice in the following format: "© 2020 UL LLC"

Zertifikat

Certificate



Zertifikat Nr. *Certificate No.*
R 50482457

Blatt *Sheet*
0001

Ihr Zeichen *Client Reference*

Unser Zeichen *Our Reference*

Ausstellungsdatum

Date of Issue

05-RW-60404416 001

24.11.2020

(day/mo/yr)

Genehmigungsinhaber *License Holder*

Dongguan Better Electronics
Technology Co., Ltd.
Room 601 of 16 Block, Xinzhu Yuan
No 4, Xinzhu Road, Songshanlake
Hightech Ind. Development Zone
523808 Dongguan City Guangdong
P.R. China

Fertigungsstätte *Manufacturing Plant*

Dongguan Better Electronics
Technology Co., Ltd.,
Second Branch Factory
No.7, Sanhe Road, Hengkeng
Administrative Zone, Liaobu Town,
Dongguan City Guangdong
P.R. China

Prüfzeichen *Test Mark*



Type Approved
Safety
Regular Production
Surveillance

www.tuv.com
ID 1111230313

Geprüft nach *Tested acc. to*

EN 60730-1:2016+A1

EN IEC 60730-2-9:2019+A1

Zertifiziertes Produkt (Geräteidentifikation)

Certified Product (Product Identification)

Lizenzentgelte - Einheit

License Fee - Unit

Temperature Control (Thermostat)

Type Designation : KSD 02xy z , KSaxy z , KSBxy z
(x=P or M, y=C or O, z=40°C-150°C) 7

Trademark: : Better (logo)

Rated Voltage : 1) AC277V; 2) DC48V

Rated Current : 1) 2A; 2) 3A

Operating Temperature : 40°C-150°C

Automatic Operation Cycles : 1) 10,000 (Automatic reset)
2) 30,000 (Automatic reset)

Type of Disconnection : Micro-interruption

Action Type : Type 2.C

Manufacturing deviation and drift: ±5°C

Degree of Protection : 2

Glow wire temperature : 850°C (for plastic shell)

PTI : 175V (for plastic shell)

Rated Impulse Voltage : 2500V

Construction : Incorporated Control for
Class I or II Equipment

Remark : The labelling requirements acc. to EU Directive
2001/95 have to be observed for distribution within the EEA.

7

ANLAGE (Appendix): 1

Dem Zertifikat liegt unsere Prüf- und Zertifizierungsordnung zugrunde und es bestätigt die Konformität des Produktes mit den oben genannten Standards und Prüfgrundlagen. Zusätzliche Anforderungen in Ländern, in denen das Produkt in Verkehr gebracht werden soll, müssen zusätzlich betrachtet werden. Die Herstellung des zertifizierten Produktes wird überwacht.

This certificate is based on our Testing and Certification Regulation and states the conformity of the product with the standards and testing requirements as indicated above. Any additional requirements in countries where the product is going to be marketed have to be considered additionally. The manufacturing of the certified product is subject to surveillance.

TÜV Rheinland LGA Products GmbH, Tillystraße 2, 90431 Nürnberg

Tel: +49 221 806-1371 e-mail: cert-validity@de.tuv.com

Fax: +49 221 806-3935 http://www.tuv.com/safety





PRODUCT CERTIFICATION

CERTIFICATE NO.: CQC21002281479

Valid from: Jan.06,2021

Valid until:long-term

NAME AND ADDRESS OF THE APPLICANT

Dongguan Better Electronics Technology Co., Ltd.
Room 601 of 16 Block, Xinzhu Yuan, No 4 , Xinzhu Road, Songshanlake Hightech Industrial Development Zone, Dongguan City

NAME AND ADDRESS OF THE MANUFACTURER

Dongguan Better Electronics Technology Co., Ltd.
Room 601 of 16 Block, Xinzhu Yuan, No 4 , Xinzhu Road, Songshanlake Hightech Industrial Development Zone, Dongguan City

NAME AND ADDRESS OF THE FACTORY

Dongguan Better Electronics Technology Co.,Ltd.
No.7, Sanhe Road, Hengkeng Administrative Zone, Liaobu Town, Dongguan City, Guangdong Province, P.R.C.

PRODUCT NAME, MODEL AND SPECIFICATION

Thermostat
KSD02 KSD 02 or KSA or KSB series (Plastic shell) 277VAC 2A 10000 cycles 50Hz or 60Hz, 48VDC 3A 30000 cycles ;Action Temperature Range :40°C-150°C , Type 2.C PTT175 Automatic reset ,Lead terminal , Pollution degree 2

THE STANDARDS AND TECHNICAL REQUIREMENTS FOR THE PRODUCTS

GB/T 14536.1-2008;GB/T 14536.10-2008

TYPE OF CERTIFICATION SCHEMES

Type Testing of Product + Initial Factory Inspection + Follow up Factory Inspection

This is to certify that the above mentioned product(s) complies with the requirements of certification rules of CQC11-448321-2016.
The validity of the certificate is subject to positive result of the regular follow up inspection by issuing certification body.

The certificate information is available through the QR code below or CNCA's website: www.cnca.gov.cn, the latter result prevails.



SIGNATURE:



CHINA QUALITY CERTIFICATION CENTRE



PRODUCT CERTIFICATION

CERTIFICATE NO.: CQC21002283395

Valid from: Jan.20,2021

Valid until:long-term

NAME AND REGISTERED ADDRESS OF THE APPLICANT Dongguan Better Electronics Technology Co., Ltd.
Room 601 of 16 Block, Xinzhu Yuan, No 4 , Xinzhu Road, Songshanlake Hightech Industrial Development Zone, Dongguan City

NAME AND REGISTERED ADDRESS OF THE MANUFACTURER Dongguan Better Electronics Technology Co., Ltd.
Room 601 of 16 Block, Xinzhu Yuan, No 4 , Xinzhu Road, Songshanlake Hightech Industrial Development Zone, Dongguan City

NAME AND LOCATION OF THE FACTORY Dongguan Better Electronics Technology Co.,Ltd.
No.7, Sanhe Road, Hengkeng Administrative Zone, Liaobu Town, Dongguan City, Guangdong Province, P.R.C.

PRODUCT NAME, MODEL AND SPECIFICATION Thermostat
KSD 02 or KSA or KSB series (Metal shell) 277VAC 2A 10000 cycles 50Hz or 60Hz, 48VDC 3A 30000 cycles ; Action Temperature Range : 40°C-150°C , Type 2. C PTI 175 Automatic reset ,Lead terminal , Pollution degree 2

THE STANDARDS AND TECHNICAL REQUIREMENTS FOR THE PRODUCTS GB/T 14536.1-2008;GB/T 14536.10-2008

TYPE OF CERTIFICATION SCHEMES Type Testing of Product + Initial Factory Inspection + Follow up Factory Inspection

This is to certify that the above mentioned product(s) complies with the requirements of certification rules of CQC11-448321-2016.
The validity of the certificate is subject to positive result of the regular follow up inspection by issuing certification body.

The certificate information is available through the QR code below or CNCA's website: www.cnca.gov.cn



SIGNATURE:



CHINA QUALITY CERTIFICATION CENTRE