

PRODUCT DATA SHEET

LINE MATCHING TRANSFORMER**P2602****Features**

- * Industry Standard
- * Lead-free (Pb-free)
- * RoHS compliant
- * 12.6mm (0.5") seated height
- * Vacuum encapsulated
- * IEC 60950 and UL 60950 Certified
- * UL Recognized Component
- * Centre-tap winding

Applications

- * V.32bis and V.22bis modems
- * Line Matching
- * Passive hybrids
- * Instrumentation
- * Fax / modems
- * Voice

DESCRIPTION

P2602 is a variant of industry standard P1200 with one centre-tapped winding.

P2602 meets international safety standards, being vacuum encapsulated and 100% tested to withstand 6.5kV DC. The part is completely lead-free, compliant with RoHS Directive 2002/95/EC, and suitable for lead-free and conventional processing.

P2602 is ideal for voice telecommunications applications and for data communications to V.32 bis (14,400 bits/second) data rates. With care, P2602 may be used for V.34 applications to 28,800 bits/second.

P2602 is specifically designed to be easily matched to both 600 ohm and complex impedance telephone lines, using a minimum of external components.

P2602 is certified to IEC 60950 and UL 60950. P2602 is a UL Recognized Component and is supported by an IEC CB Test Certificate.

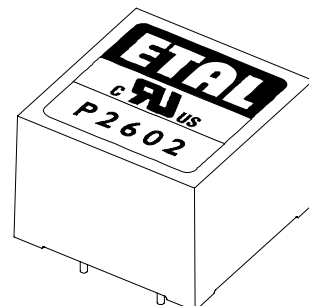

SPECIFICATIONS

Electrical

At T = 25°C and as circuit fig. 2 unless otherwise stated.

Parameter	Conditions	Min	Typ	Max	Units
Insertion Loss	f = 2kHz, R _L = 560Ω	-	-	1.5	dB
Frequency response	LF-3dB cutoff	-	-	50	Hz
	HF-3dB cutoff	10	-	-	kHz
	200Hz - 4kHz	-	-	±0.2	dB
Return Loss	200Hz - 4kHz	18	-	-	dB
Third Harmonic Distortion ⁽¹⁾	450Hz 0dBm	-	-72	-60	dBm
Balance	DC – 5kHz Method TG25	80	-	-	dB
Saturation	Excitation 50Hz 250V rms. Output voltage across line	-	-	10	V rms
		-	-	65	V peak
Voltage isolation ⁽²⁾	50Hz	3.88	-	-	kVrms
	DC	5.5	-	-	kV
Operating range: Functional Storage	Ambient temperature	-25	-	+85	°C
		-40	-	+125	°C

Lumped equivalent circuit parameters as Fig. 1

DC resistance, R _{DC} ⁽³⁾⁽⁵⁾	Sum of windings	120	-	148	Ω
Leakage inductance ΔL		14.5	-	18	mH
Shunt inductance L _p ⁽⁴⁾	10mV 200Hz	2.8	8	-	H
	10mV 1kHz	-	2	-	H
Shunt loss R _p ⁽⁴⁾	10mV 200Hz	5	-	-	kΩ
	10mV 1kHz	7	-	-	kΩ

Notes

1. Third harmonic typically exceeds other harmonics by 20dB.
2. Components are 100% tested at 6.5kV DC.
3. Caution: do not pass DC through windings. Telephone line current, etc. must be diverted using choke or semiconductor line hold circuit.
4. At signal levels greater than 100mV, L_p will increase and R_p will decrease slightly but the effect is usually favourable to the return loss characteristic.
5. Resistance imbalance between the two

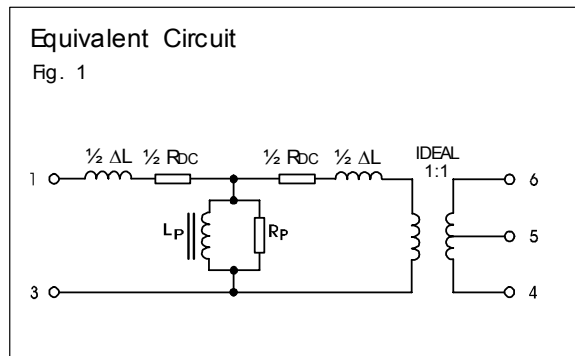

halves of the tapped winding will not be greater than 5Ω.

MATCHING RECOMMENDATIONS

600Ω MATCH

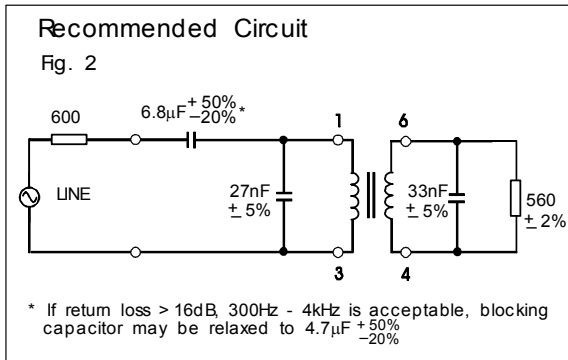
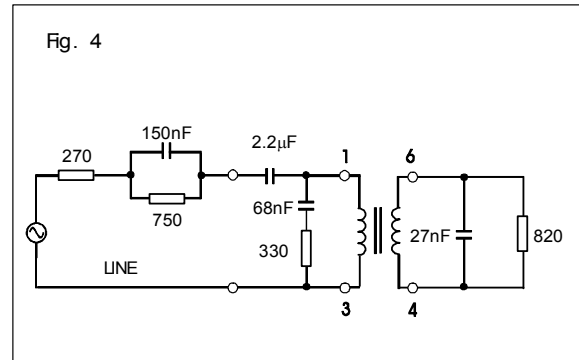
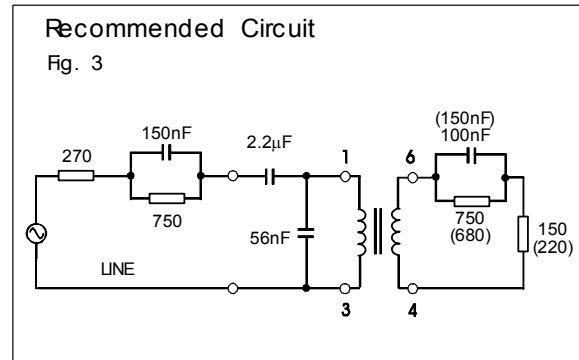

Figure 3 gives flat RX and TX responses against the CTR21 complex reference impedance (typically around ±0.5dB 300Hz - 3.4kHz). Return loss is typically better than 20dB. The circuit values in parentheses give optimum flatness at a small sacrifice in return loss.

For circuits with existing board drillings, figure 4 gives good return loss (>20dB) and RX flatness against the CTR21 complex reference impedance, but TX flatness is degraded by the use of this topology.

EUROPEAN CTR21 COMPLEX MATCH



CONSTRUCTION

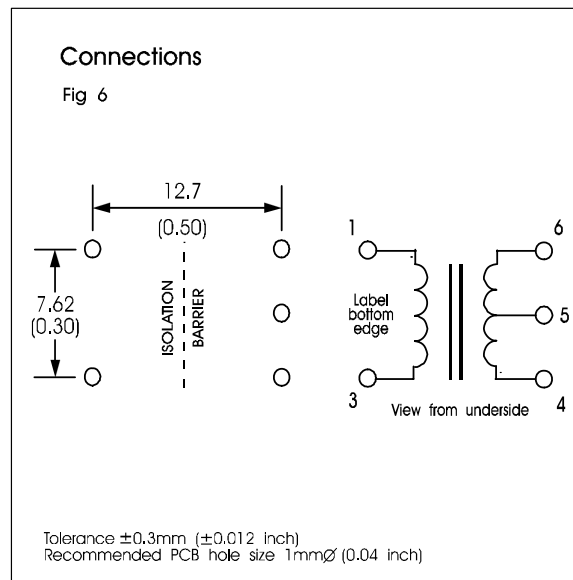
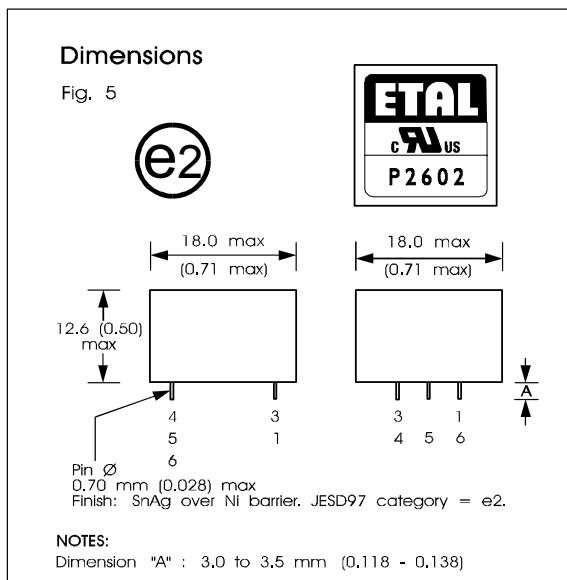

Dimensions shown are in millimetres (inches).

Geometric centres of outline and pin grid coincide within a tolerance circle of 0.6mm

SAFETY

Constructed in accordance with IEC 60950-1:2001, EN 60950-1:2001 and UL 60950-1 First Edition, supplementary insulation, 250Vrms maximum working voltage, flammability class V-0. Distances through solid insulation 0.4mm minimum.

CERTIFICATION

Certified under the IEC CB scheme (Certificate DK-9431) to IEC 60950-1:2001, sub-clauses 1.5, 1.5.1, 1.5.2, 1.7, 1.7.1, 2, 2.9, 2.9.1, 2.9.2, 2.9.3, 2.10, 2.10.1, 2.10.2, 2.10.3, 2.10.3.1, 2.10.3.3, 2.10.4, 2.10.5, 2.10.5.1, 2.10.5.4, 4, 4.7, 4.7.1, 4.7.3, 4.7.3.1, 4.7.3.4, 5, 5.2, 5.2.1, and 5.2.2 for a maximum working voltage of 250Vrms, nominal mains supply voltage not exceeding 300Vrms and a maximum operating temperature of 85°C in Pollution Degree 2 environments, supplementary insulation, including national differences for Denmark, Finland, Germany, Norway, Sweden, Switzerland, USA, Canada and UK. Recognized under the Component Recognition Program of Underwriters Laboratories Inc. to US and Canadian requirements CAN/CSA C22.2 No. 60950-1-03/UL60950-1, First Edition, based on IEC 60950-1, First Edition, maximum working voltage 250Vrms, Pollution Degree 2, reinforced insulation.

UL File number E203175.

Additionally, ETAL certifies all transformers as providing voltage isolation of 3.88kVrms, 5.5kV DC minimum. All shipments are supported by a certificate of conformity to current applicable safety standards.

ABSOLUTE MAXIMUM RATINGS

(Ratings of components independent of circuit).

Short term isolation voltage (1s)	4.6kVrms, 6.5kV DC
DC polarizing current	100µA
Storage temperature	-40°C to +125°C
Lead temperature, 10s	260°C

COPYRIGHT

ETAL, P1200 and P2602 are Trade Marks of Profec Technologies Ltd. The Trade Mark ETAL is registered at the UK Trade Marks Registry.

Profec Technologies Ltd. is the owner of the design right under the Copyright Designs and Patents Act 1988 and no rights or licences are hereby granted or implied to any third party.

© 1996 - 2006 Profec Technologies Ltd.
Reproduction prohibited.



ISO 9001
FM 25326

ETAL Group Oy, Kuormatie 14, FIN-03101, Nummela
Telephone: +358 (0)20 7500 330 Fax: +358 (0)20 7500 333
Website: www.etalgroup.com Email: etalgroup@egruppen.com