



C3A(G)

塑料外壳干式直流滤波电容器 (温度85℃)

DC-Link Capacitor (Dry-Type, Plastic case, Temperature 85℃)

■ 外形图 Outline Drawing

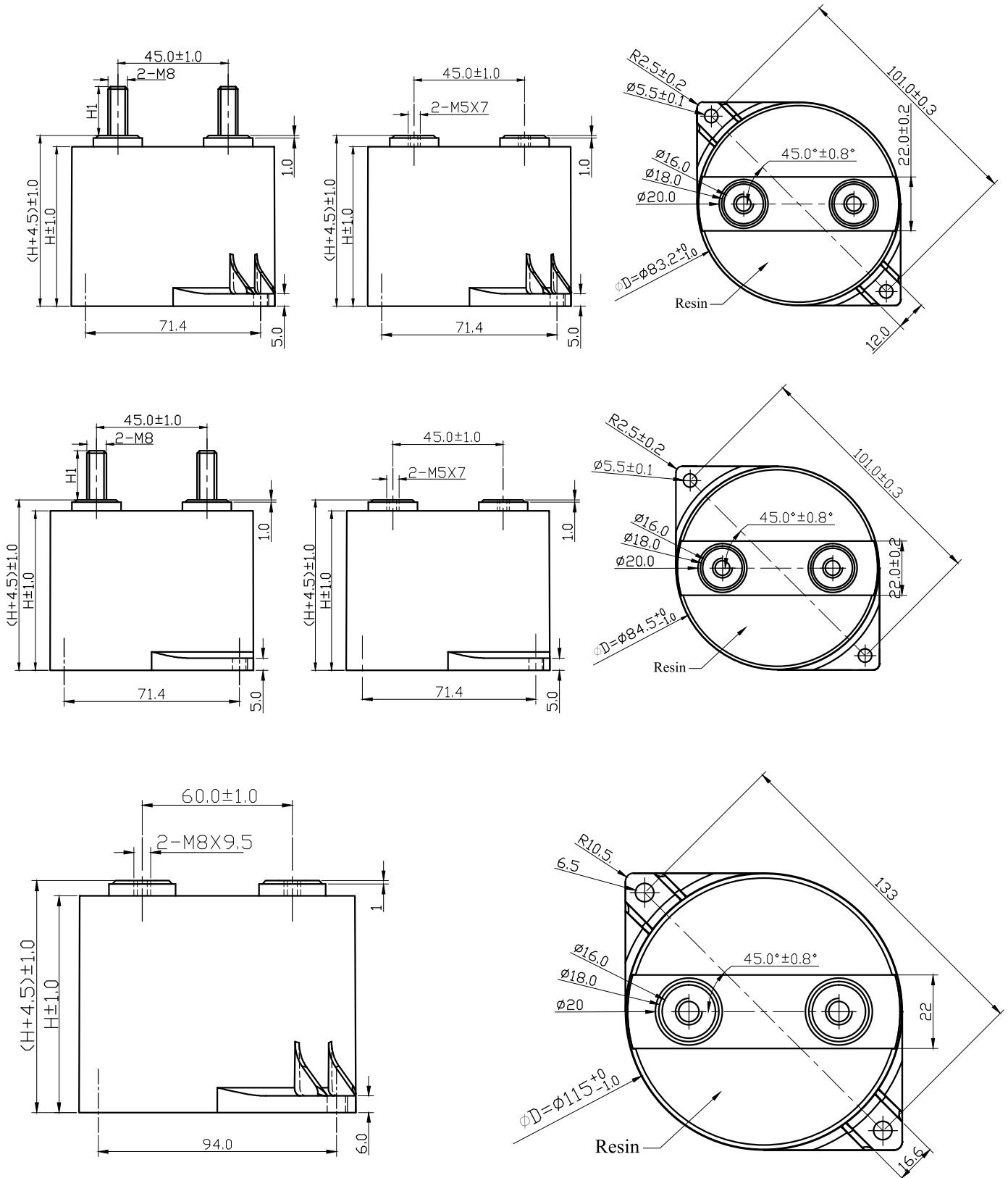



■ 特点

- 应用于直流滤波电路中，可替代电解电容器
- 等效串联电阻小，能承受较大的纹波电流
- 自感小
- 有自愈性
- 寿命长
- 塑料外壳，树脂灌封

■ 应用场合

- 风能发电、太阳能发电用变频器上
- 焊接设备，电梯，电机驱动

■ 安全认证 Safety Approvals

●		TUV Rheinland (德国)	EN 61071:2007, EN 61881-1:2011, 450Vdc ~ 1500Vdc, 10.0μF ~ 600.0μF, -40°C/85°C 证书号(Certificate No.): R 50266007
●		UL(美国)	UL 810(construction only), max 5000Vdc, 90°C 证书号(File No.): E256238, CCN:CZDS2

■ 技术要求 Specifications

引用标准 Reference Standard	GB/T 17702 (IEC 61071)	
气候类别 Climatic Category	40/85/56	
工作温度范围 Operating Temperature Range	-40°C ~ 85°C ($\Theta_{hs} \leq 85^\circ\text{C}$)	
贮存温度范围 Storage Temperature Range	-40°C ~ 85°C	
电压范围 Voltage Range	600Vdc ~ 1 500Vdc	
容量范围 Capacitance Range	35μF ~ 600μF	
电容量允许偏差 Capacitance Tolerance	± 5%(J); ± 10%(K)	
耐电压 Voltage Proof	极间 Between Terminals:	1.5U _N (10s, 20°C ± 5°C)
	极壳之间 Between Terminals And Case:	3 000Vac(10s, 50Hz, 20°C ± 5°C)
介质损耗角正切 tg δ _d	0.0002	
IR × C _N	≥ 5 000s (20°C ,100Vdc,1min)	
过电压 Over Voltage	1.1U _N (30% of on-load-dur.)	
	1.15U _N (30min/day)	
	1.2U _N (5min/day)	
	1.3U _N (1min/day)	
	1.5U _N (30ms every time, 1 000 times during the life of the capacitor)	
最高使用海拔 Max. Altitude	2 000m	
最大电极扭矩 Max. Torque of terminals	M5: 2.5Nm	M8:6.0Nm
最大安装扭矩 Max. Torque of Installation	3.0Nm	
安装 Installation	任意方向 Any Position	
预期寿命 Expected lifetime	参考预期寿命曲线 Refer to Expected lifetime curve	
失效率 Failure rate	50FIT	

备注：如果海拔使用高度超过了2 000m，应该考虑海拔对对流冷却和外绝缘的影响。

The effect of altitude on convection cooling and external insulation should be taken into consideration, if the altitude exceeds 2 000m.



C3A(G)

产品编码说明 Part number system

■ 18位产品代码如下：

The 15 digits part number is formed as follow:

1	2	3	4	5	6	7	8	9	10	11	12	13	14	15	16	17	18
C	3	A							G								

第1~3位	型号代码	Digit 1 to 3	Series code
第4~5位	直流额定电压 1U=600V 2K=800V 1X=900V 1M=1 100V 3L=1 200V 2M=1 300V 3M=1 400V 4M=1 500V	Digit 4 to 5	DC rated voltage 1U=600V 2K=800V 1X=900V 1M=1 100V 3L=1 200V 2M=1 300V 3M=1 400V 4M=1 500V
第6~8位	标称容量 举例：127=12 × 10 ⁷ pF=120μF	Digit 6 to 8	Rated capacitance value For example: 127=12 × 10 ⁷ pF=120μF
第9位	容量等级 J= ± 5% K= ± 10%	Digit 9	Capacitance tolerance J= ± 5%,K= ± 10%,
第10位	外形尺寸代码	Digit 10	Dimension code

C3A Dimension code		
ΦD	H	Code
84.5	65	1
84.5	50	2
84.5	41	3
83.2	65	4
84.5	76	5
115.0	64	6

第11位	内部特征码	Digit 11	Internal use
第12~15位	引出端代码	Digit 12 to 15	Terminals code

■ Table 1 引出端代码 Terminals code

Male terminals code

第 12 位 Digit 12		第 13 位 Digit 13		第 14 位 Digit 14		第 15 位 Digit 15	
代码 Code	引出端形式 Terminal form	代码 Code	安装形式 Fix style	代码 Code	引出端长度 Length of terminals	代码 Code	引出端规格 Specifications of terminal
2	螺栓式 Male Terminals	B	下双耳 Double mounting ears in the bottom of the case	0	20mm	0	M8
				1	11mm		
				2	16mm		

Female terminals code

第 12 位 Digit 12		第 13 位 Digit 13		第 14 位 Digit 14		第 15 位 Digit 15	
代码 Code	引出端形式 Terminal form	代码 Code	安装形式 Fix style	代码 Code	引出端深度 Depth of terminals	代码 Code	引出端规格 Specifications of terminal
H	螺孔式 Thread hole type	B	下双耳 Double mounting ears in the bottom of the case	3	7mm	7	M5
				4	9.5mm	1	M8

第16~18位	内部特征码	Digit 16 to 18	Internal use
---------	-------	----------------	--------------

■ 技术参数 Technical data (mm)

U _N (Vdc)	C _N (μF)	ESR @10kHz (mΩ)	L _s (nH)	R _{th} (K/W)	Î (A)	I _{max} (A)		Dimension		Weight (kg)	Part number	Expected lifetime
						55℃	65℃	ΦD	H			
600	170	0.8	25	6.8	2 051	74	60	84.5	41	≈ 0.35	C3A1U177-3G****+++	Lifetime curve
	260	0.9	32	5.3	2 193	79	64	84.5	50	≈ 0.40	C3A1U267-2G****+++	
	380	1.0	40	5.0	2 135	77	63	84.5	65	≈ 0.48	C3A1U387-1G****+++	
	380	1.0	40	5.2	2 135	76	62	83.2	65	≈ 0.47	C3A1U387-4G****+++	
	600	1.1	40	3.4	3 791	89	73	115.0	64	≈ 0.90	C3A1U607-6G****+++	
800	100	0.9	25	6.8	2 074	70	57	84.5	41	≈ 0.35	C3A2K107-3G****+++	
	150	1.0	32	5.3	2 174	75	61	84.5	50	≈ 0.40	C3A2K157-2G****+++	
	220	1.1	40	5.0	2 123	73	60	84.5	65	≈ 0.48	C3A2K227-1G****+++	
	220	1.1	40	5.2	2 123	72	59	83.2	65	≈ 0.47	C3A2K227-4G****+++	
	350	1.3	40	3.4	3 798	82	67	115.0	64	≈ 0.90	C3A2K357-6G****+++	
900	100	0.9	25	6.8	2 074	70	57	84.5	41	≈ 0.35	C3A1X107-3G****+++	
	150	1.0	32	5.3	2 174	75	61	84.5	50	≈ 0.40	C3A1X157-2G****+++	
	220	1.1	40	5.0	2 123	73	60	84.5	65	≈ 0.48	C3A1X227-1G****+++	
	220	1.1	40	5.2	2 123	72	59	83.2	65	≈ 0.47	C3A1X227-4G****+++	
	350	1.3	40	3.4	3 798	82	67	115.0	64	≈ 0.90	C3A1X357-6G****+++	
1 100	66	1.2	25	6.8	1 828	60	49	84.5	41	≈ 0.35	C3A1M666-3G****+++	
	100	1.3	32	5.3	1 936	66	53	84.5	50	≈ 0.40	C3A1M107-2G****+++	
	140	1.5	40	5.0	1 805	63	51	84.5	65	≈ 0.48	C3A1M147-1G****+++	
	140	1.5	40	5.2	1 805	62	50	83.2	65	≈ 0.47	C3A1M147-4G****+++	
	190	1.7	45	4.6	2 003	61	50	84.5	76	≈ 0.55	C3A1M197-5G****+++	
	150	1.5	45	4.6	1 861	65	53	84.5	76	≈ 0.55	C3A1M157-5G****+++	
	230	1.4	40	3.4	3 333	79	64	115.0	64	≈ 0.90	C3A1M237-6G****+++	
1 300	47	1.3	25	6.8	1 780	58	47	84.5	41	≈ 0.35	C3A2M476-3G****+++	
	70	1.4	32	5.3	1 853	63	51	84.5	50	≈ 0.40	C3A2M706-2G****+++	
	100	1.8	40	5.0	1 763	57	47	84.5	65	≈ 0.48	C3A2M107-1G****+++	
	100	1.8	40	5.2	1 763	56	46	83.2	65	≈ 0.47	C3A2M107-4G****+++	
	130	1.9	45	4.6	1 874	58	47	84.5	76	≈ 0.55	C3A2M137-5G****+++	
	160	1.6	40	3.4	3 170	74	60	115.0	64	≈ 0.90	C3A2M167-6G****+++	
1 400	40	1.3	25	6.8	1 742	58	47	84.5	41	≈ 0.35	C3A3M406-3G****+++	
	56	1.5	32	5.3	1 735	61	50	84.5	50	≈ 0.40	C3A3M566-2G****+++	
	86	1.8	40	5.0	1 743	57	47	84.5	65	≈ 0.48	C3A3M866-1G****+++	
	86	1.8	40	5.2	1 743	56	46	83.2	65	≈ 0.47	C3A3M866-4G****+++	
	110	1.9	45	4.6	1 823	58	47	84.5	76	≈ 0.55	C3A3M117-5G****+++	
	130	1.7	40	3.4	2 961	72	58	115.0	64	≈ 0.90	C3A3M137-6G****+++	
1 500	35	1.4	25	6.8	1 198	56	45	84.5	41	≈ 0.35	C3A4M356-3G****+++	
	50	1.6	32	5.3	1 636	59	48	84.5	50	≈ 0.40	C3A4M506-2G****+++	
	76	1.9	40	5.0	1 656	56	45	84.5	65	≈ 0.48	C3A4M766-1G****+++	
	76	1.9	40	5.2	1 656	55	45	83.2	65	≈ 0.47	C3A4M766-4G****+++	
	95	2.1	45	4.6	1 692	55	45	84.5	76	≈ 0.55	C3A4M956-5G****+++	
	110	1.8	40	3.4	2 693	70	57	115.0	64	≈ 0.90	C3A4M117-6G****+++	



C3A(G)

■ 预期寿命曲线 Expected lifetime curve

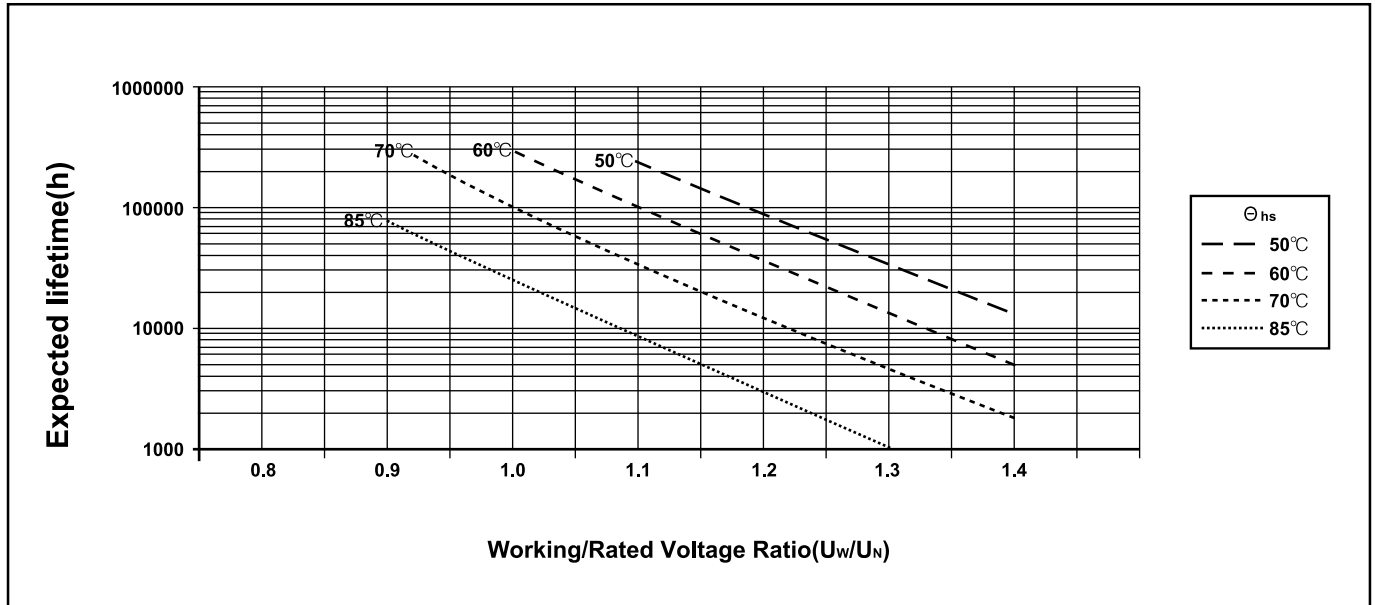

- 备注: 1. “-”表示容量偏差。“-”=capacitance tolerance code, J= ± 5%, K= ± 10%.
2. “****”表示引出端代码(见table1),引出端子可以选用螺栓式或螺孔式。
“****”=terminals code(refer to table1),terminals can be male or female.
3. “+++”表示内部特征码。“+++”=Internal use.
4. “I_{max}”是指在环境温度下的最大电流有效值。在这种条件下,热点温度将达到最大值。
“I_{max}” = Maxium r.m.s current at Θ_{amb} . Θ_{hs} will reach the maximum value on this condition.
5. “R_{th}”是指在自然冷却条件下,电容器热点到环境的热阻。
“R_{th}” = R_{th} between hotspot and ambient on natural cooling condition.
- 6.引出端子长度H1可按客户需要商定(见table1)。The length of terminals H1 available on request (refer to table1).
- 7.其它容量、尺寸系列可按用户需要商定。Other capacitance and dimensions are available on request.
- 8.* $\Theta_{hs} = \Theta_{amb} + I_{rms}^2 \times ESR \times R_{th}$.