

**WIRE WOUND RESISTORS
CERAMIC ENCASED TYPE**

**HCL
SERIES
HI POWER TYPE
Ceramic Encased
Wire Wound Resistors
Industrial Applications**

- 10 W to 40 W
- Can be supplied with mounting brackets.
- Choice of quick connect terminals available.
- R10 to 68K

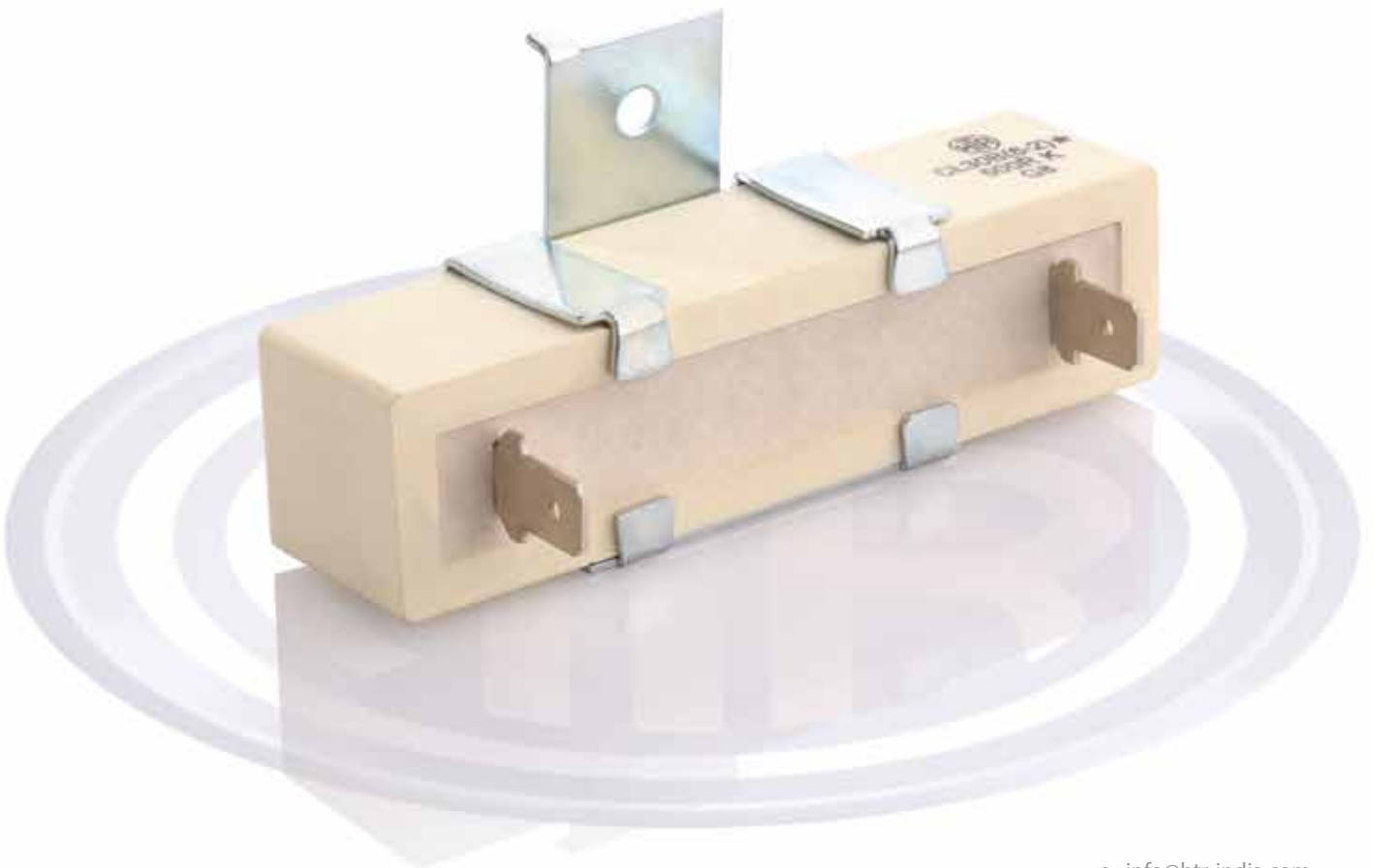



WIRE WOUND
RESISTORS
CERAMIC
ENCASED TYPE
HCL

PHYSICAL CONFIGURATION

AMP F 187 Compatible Terminal

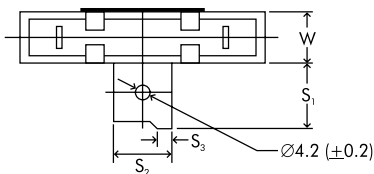
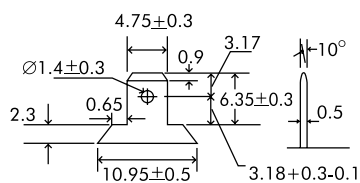

AMP 250 Compatible Terminal

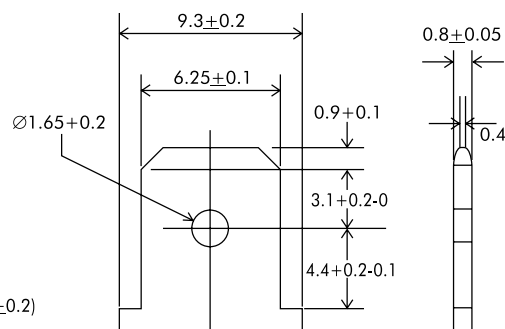

AMP F 187 Compatible

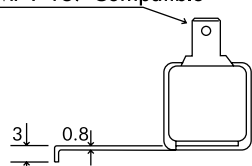

ELEVATION - A

PROFILES

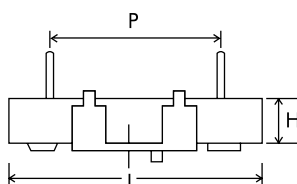

AMP 250 Compatible

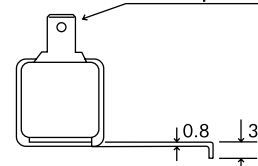

ELEVATION - B

HTR TYPE	POWER RATING at 70°C	DIMENSIONS (mm)							RESISTANCE RANGE		TYPICAL WEIGHT PER PC (gms)	TYPICAL WEIGHT PER PC FITTED WITH BRCT. (gms)
		L ±1.5	W ±1	H ±1	P ±1.5	S1 ±1	S2 ±0.5	S3 ±0.5	min	max		
CL-10	10W	48.0	9.5	9.5	35.0	(No Mounting Bracket)			R10	47K	11.0	-
CL-15	15W	48.0	12.5	12.5	35.0	14.0	12.0	3.0	R10	47K	18.5	24.5
CL-20	20W	63.5	12.5	12.5	48.0	14.0	12.0	3.0	R10	56K	22.0	28.0
CL-30	30W	76.0 (±2.0)	19.0	19.0	56.0	16.5	18.0	3.0	R20	64K	65.0	79.0
CL-40	40W	90.0 (±2.0)	19.0	19.0	71.0	16.5	18.0	3.0	1R0	68K	72.0	86.0

DERATING CURVE

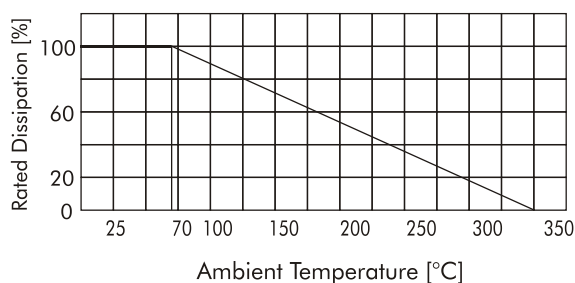

ELECTRICAL CHARACTERISTICS / DATA

PARAMETER/PERFORMANCE TEST & TEST METHOD	PERFORMANCE REQUIREMENTS
Power Rating (Rated Ambient Temperature) to zero at 350°C (Refer Derating curve above)	Full Power dissipation at 70°C and linearly derated
Operating Temperature Range (Ambient)	-55°C to +350°C with suitable derating as per derating curve shown
Voltage Rating / Limiting Voltage / Max Working Voltage	$V = \sqrt{P \times R}$
Maximum Overload Voltage	Varies depending on resistance value, duration of overload and type of pulse waveform. (contact factory for details)
Resistance Tolerances Available (JIS- C - 5202 para 5.1)	±10% (K); ±5% (J)



WIRE WOUND
RESISTORS
CERAMIC
ENCASED TYPE
HCL

ELECTRICAL AND ENVIRONMENTAL CHARACTERISTICS / DATA

PARAMETER/ PERFORMANCE TEST	TEST METHOD- DETAILS	PERFORMANCE REQUIREMENTS
Short Time Overload	JIS-C-5202 Para 5.5 Condition B (voltage corresponding to 10 times power for 5 secs)	$\Delta R \pm [2\% + R05]$
Dielectric Withstanding Voltage / Voltage Proof	JIS - C - 5202 Para 5.7 Condition F (Limiting Voltage x 2 or 500V)	$\Delta R \pm [1\% + R05]$
Temperature Co-efficient of Resistance	JIS - C - 5202 Para 5.2	$\pm 90 \text{ ppm}/^\circ\text{C} [>10R]$ $\pm 80 \text{ ppm}/^\circ\text{C} [<10R]$ $\pm 200 \text{ ppm}/^\circ\text{C} [<R10]$
Insulation Resistance	JIS - C - 5202 Para 5.6 (condition F)	$> 1000M\Omega$ (min)
Pulse Overload / Intermittent Overload	JIS - C - 5202 Para 5.8 (Limiting Voltage x 4) 1 sec on / 25 secs off 10,000 cycles ± 200 cycles	$\Delta R \pm [2\% + R05]$
Endurance - under load with humidity	JIS - C - 5202 Para 7.9 1000 hours at $40^\circ\text{C} \pm 2^\circ\text{C}$, 95% R.H with limiting voltage (1.5 hours on / 0.5 hours off)	$\Delta R \pm [5\% + R05]$ - Typical
Load Life	JIS - C - 5202 Para 7.10 1000 hours at 70°C with limiting voltage (1.5 hours on/0.5 hours off)	$\Delta R \pm [3.5\% + R05]$ - Average
Temperature Cycling	JIS - C - 5202 Para 7.4 [Room Temperature $\rightarrow -55^\circ\text{C} \rightarrow$ Room Temperature $\rightarrow 155^\circ\text{C} \rightarrow$ Room Temperature for 5 cycles]	$\Delta R \pm [2\% + R05]$ - Typical
Damp Heat (Steady State)	JIS - C - 5202 Para 7.5	$\Delta R \pm [3\% + R05]$ - Average
Solvent Resistance	JIS - C - 5202 Para 6.9 Solvent A - IPA for 60 secs ± 10 secs	No effect on case filling or marking

MECHANICAL SPECIFICATIONS

PARAMETER/ PERFORMANCE TEST	TEST METHOD- DETAILS	PERFORMANCE REQUIREMENTS
Pull Test / Robustness of Terminations	Direct Load for 15 secs 2 to 4.5 kgs depending on size	No effect
Solderability	JIS - C - 5202 Para 6.5 (Applicable to tin plated terminations only) Dwell time in solder 2 secs ± 0.5 sec	$\Delta R \pm [1\% + R05]$ Continuous and satisfactory (95% Min coverage)

TYPICAL APPLICATIONS

HCL Series has been developed in the Far East as a direct replacement for old style radial wire wound resistors. As they can be provided with fitted mounting brackets, they are suitable for use in situations where shock and high frequency vibration forces are to be encountered.

HCL Series also offers the following advantages -

a) High degree of insulation b) Low surface temperature as the bracket itself acts to some extent as a heat sink.

These resistors can also be supplied with a choice of receptacle type quick connect terminals which are compatible with AMP connector F187 and 250. Please refer ordering information.

Note: Due to recent technological advances, the ceramic cases used may be steatite ceramic or cordierite ceramic or high alumina ceramic depending on the nature of the application. Hence the ceramic cases may be off-white or variations of brown and variations of grey; colours which are inherent to these ceramic materials

ORDERING INFORMATION

Series	HTR type	Choice of Mounting	LUG	RoHS Compliance	Resistance Value	Tolerance
HCL	CL-20	B	6.2	*	15R	J

- For RoHS version - CL-20 *
- For Choice of Mounting
 - If no bracket is required, to be left blank.
 - If M.S. bracket required - CL-20 B
 - If S.S. bracket is required - CL-20 BS
- The Mounting Bracket 'B' will be zinc plated mild steel with trivalent passivator to meet RoHS norms. The Mounting Bracket 'BS' will be stainless steel.
- If lug required is compatible with Amp F187 - CL20 4.7
 - If lug required is compatible with Amp 250 - CL20 6.2
- CL20 type with Bracket 'B', compatible with Amp 250 and RoHS compliant would be - CL20B 6.2 *