

WIRE WOUND RESISTORS
HSR/HSRC
SERIES
SYMMERTY WIRE WOUND RESISTORS
High Power Capacitor
Discharge Resistors

- 8.25W to 25W
- 10K to 120K





WIRE WOUND
RESISTORS
**HSR/
HSRC**

PHYSICAL CONFIGURATION (Coated Style) - HSR Series

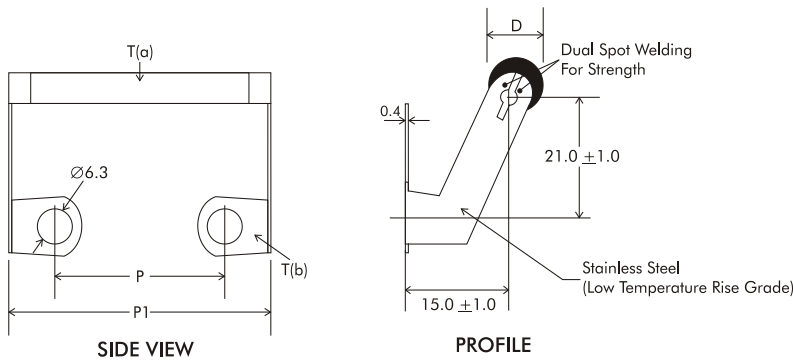

HTR TYPE	POWER RATING		DIMENSIONS (mm)			TEMP. AT FULL POWER ON BODY T(a) & ON INTERFACE WITH CAPACITOR T(b) [AMB TEMP 30°C]		RESISTANCE RANGE		TYPICAL WEIGHT PER PC (gms)
	at 70°C	at 25°C	D ±1.0	P ±1.0	P1 (max)	T(a)	T(b)	min	max	
SR8	8.25W	10W	9.65	22.30	38.0	260°C	57°C	10K	75K	8.0
SR11	11W	13W	9.65	31.85	49.0	264°C	59°C	10K	110K	8.75
SR20	20W	25W	9.65	48.85	66.0	300°C	65°C	10K	120K	13.00

* Resistance value lower than the above are possible on request

PHYSICAL CONFIGURATION (Ceramic Encased Style) - HSRC Series

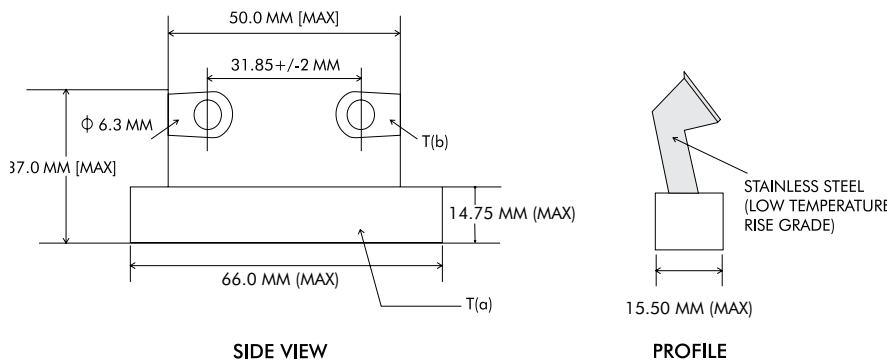

HTR TYPE	POWER RATING		TEMPERATURE AT FULL POWER ON BODY T(a) & ON INTERFACE WITH CAPACITOR T(b) [AMB TEMP 30°C]		RESISTANCE RANGE		TYPICAL WEIGHT PER PC (gms)
	at 70°C	at 25°C	T(a)	T(b)	min	max	
SRC11	11W	13W	258°C	50°C	10K	110K	27
SRC20	20W	22W	264°C	52°C	10K	110K	27
SRC25	25W	27W	278°C	52°C	10K	110K	27

DERATING CURVE

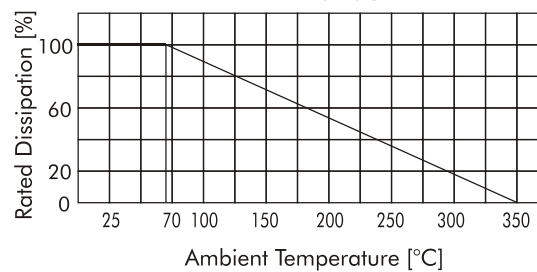



WIRE WOUND
RESISTORS
**HSR/
HSRC**

ELECTRICAL & ENVIRONMENTAL CHARACTERISTICS / DATA

PARAMETER/PERFORMANCE TEST & TEST METHOD	PERFORMANCE REQUIREMENTS
Power Rating (Rated Ambient Temperature) to zero at 350°C (Refer Derating Curve above)	Full Power dissipation at 70°C and linearly derated
Resistance Tolerances Available	±10% (K); ±5% (J); ±3% (H); ±2% (G); ±1% (F)
Temperature Range	-55°C to +350°C with suitable derating as per derating curve
Voltage Rating / Limiting Voltage / Max. Working Voltage	$V = \sqrt{P \times R}$
Voltage Proof / Dielectric Withstanding Voltage (based on limiting voltage x 2 or 500V whichever is applicable)	$\Delta R \pm [1\% + R05]$
Temperature Co-efficient of Resistance	± 90 or ± 30 ppm/°C depending on wire selected
Short Time Overload (10 x Rated Power for 5 secs)	$\Delta R \pm [2\% + R05]$
Insulation Resistance (Test Method no. 302 of MIL 202F)	>1000M (Dry) >100M (Wet)
Endurance - Load life (70°C with limiting voltage - 1.5 hours on / 0.5 hours off for 1000 hours)	$\Delta R \pm [\leq 5\% + R05]$
Solvent Resistance (IPA for 60 secs ± 10 secs)	No effect on coating / marking or case filling
Vibration Test (As per IEC 60571-1)	No effect

TYPICAL APPLICATIONS

- These high power wire wound resistors have low temperature rise stainless steel mounting lugs fitted to them at a pitch which is ideally suitable to mount on capacitors and are used mainly for voltage balancing of aluminium electrolytic capacitors connected in series.
- These resistors are also used in safety applications; wherein they have been found suitable for capacitor voltage discharge applications in high voltage circuits.

Note:

The ceramic cases used may be steatite ceramic or cordierite ceramic or high alumina ceramic. Hence, the ceramic cases may be offwhite or variations of brown and variations of grey; colours which are inherent to these ceramic materials.

ORDERING INFORMATION

Series	Type	Packing	Resistance Value	Tolerance
HSR /	SR8/SR8*	Bulk SR8/SR8*	15K	J
HSRC	SRC25/SRC25*	Bulk SRC25/SRC25*		

For RoHS version - SR11* / SRC25*