

21PCT200T4-0016
(21PCT200T4-Y/R)

Yellow/Hi-Eff Red

LEDs, PC Board, T1³/₄ (5mm) Right-Angled Bi-Level
60° viewing angle

DWG BY:

GP

06-15-07

CHK BY:

PL

06-18-07

QA:

__-__-__

MFG:

__-__-__

REVISION LTR: -

06-15-07

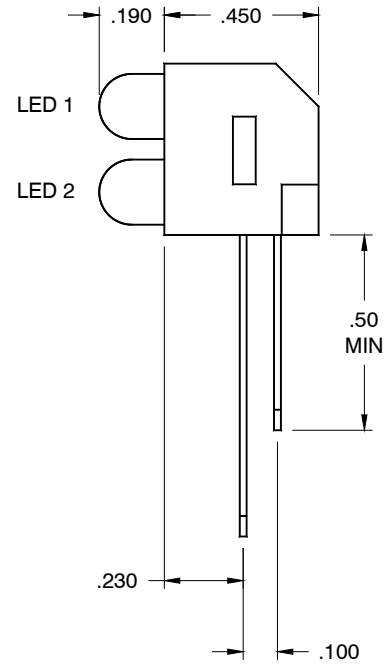
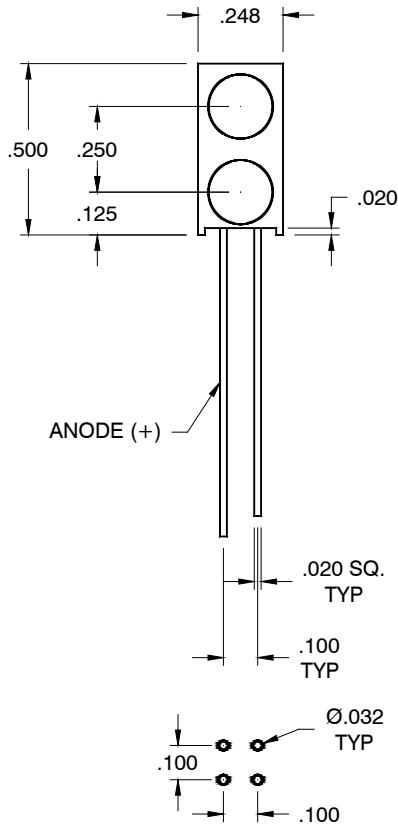

● **Absolute Maximum Ratings(Ta=25°C)**

| Parameter | Symbol | Yellow | Red | Unit |
|------------------------------------|-----------------|-----------------------|-----|------|
| Power Dissipation | Pd | 80 | 80 | mW |
| Forward Current | I _F | 30 | 30 | mA |
| Peak Forward Current* ¹ | I _{FP} | 150 | 150 | mA |
| Reverse Voltage | V _R | 5 | | V |
| Operating Temperature | Topr | -40°C~80°C | | |
| Storage Temperature | Tstg | -40°C~85°C | | |
| Soldering Temperature | Tsol | 260°C (for 5 seconds) | | |

*¹Condition for I_{FP} is pulse of 1/10 duty and 0.1msec width.

● **Electrical and optical characteristics(Ta=25°C)**

| Parameter | Symbol | Condition | Color | Min. | Typ. | Max. | Unit |
|--------------------------|-------------------|----------------------|----------------------|------|------------|------------|------|
| Forward Voltage | V _F | I _F =20mA | Yellow Hi-Eff Red | - | 2.1 2.0 | 2.6 2.6 | V |
| Luminous Intensity | I _v | I _F =20mA | Yellow Hi-Eff Red | - | 30 35 | - | mcd |
| Reverse Current | I _R | V _R =5V | Yellow Hi-Eff Red | - | - | 100 | μA |
| Peak Wave Length | λ _p | I _F =20mA | Yellow Hi-Eff Red | - | 581 644 | - | nm |
| Dominant Wave Length | λ _d | I _F =20mA | Yellow Hi-Eff Red | - | 584 630 | - | nm |
| Spectral Line Half-width | Δλ | I _F =20mA | Yellow Hi-Eff Red | - | 35 42 | - | nm |
| Viewing Angle | 2θ _{1/2} | I _F =20mA | Yellow Hi-Eff Red | - | 60 | - | deg |
| Chromaticity Coordinates | X | I _F =20mA | Yellow | - | 0.54 | - | |
| | Y | | | | 0.45 | | |
| Chromaticity Coordinates | X | I _F =20mA | Hi-Eff Red | - | 0.71 | - | |
| | Y | | | | 0.29 | | |

● **Typical Electro-Optical Characteristics Curves (Yellow)**

Fig.1 Relative intensity vs. Wavelength

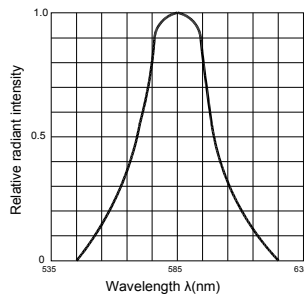

Fig.2 Forward current derating curve vs. Ambient temperature

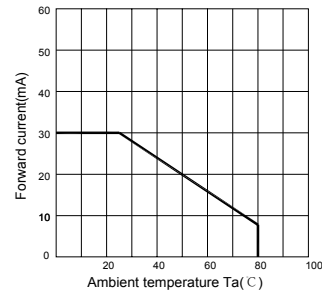

Fig.3 Forward current vs. Forward voltage

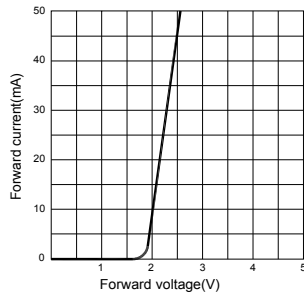

Fig.4 Relative luminous intensity vs. Ambient temperature

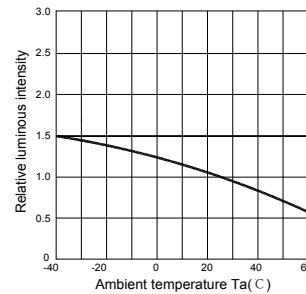

Fig.5 Relative luminous intensity vs. Forward current

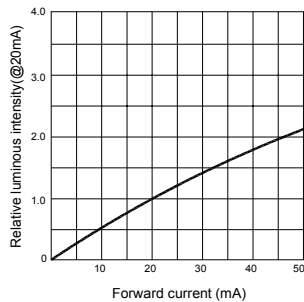
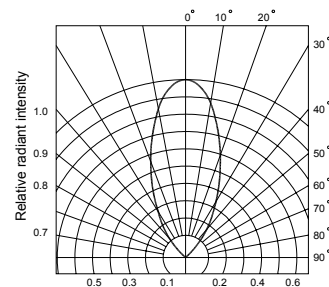

Fig.6 Radiation diagram



● **Typical Electro-Optical Characteristics Curves (Red)**

Fig.1 Relative intensity vs. Wavelength

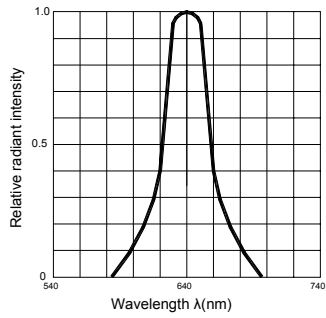

Fig.2 Forward current derating curve vs. Ambient temperature

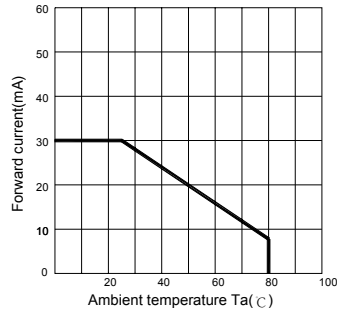

Fig.3 Forward current vs. Forward voltage

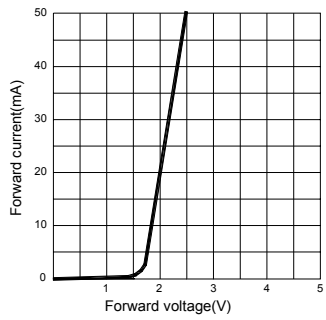

Fig.4 Relative luminous intensity vs. Ambient temperature

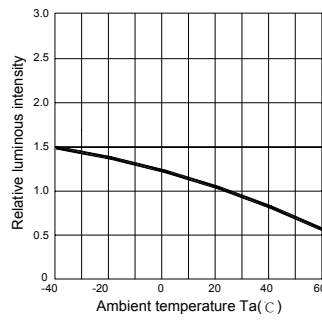

Fig.5 Relative luminous intensity vs. Forward current

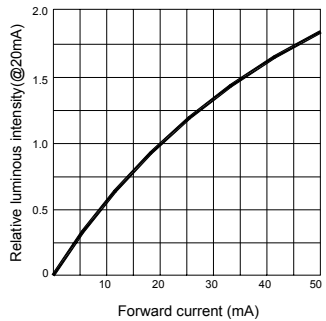

Fig.6 Radiation diagram

