

**FEATURES**

- ✘ Guiding post offers easy orientation
- ✘ 3.80 & 5.30mm stem height available

**APPLICATION**

- ✘ DSC
- ✘ Detection of disc loading

**SPECIFICATION**

Contact Rating	1mA, 5V DC
Contact Resistance	1Ω max.
Insulation Resistance	100MΩ min. 100V DC
Dielectric Strength	100V AC/1 minute
Operating Force	40gf max.
Travel	3.9mm max. Stem Height 5.3mm 2.6mm max. Stem Height 3.8mm
Operating Life	100,000 cycles
Operating Temp.	-10°C ~ +60°C
Storage Temp.	-40°C ~ +80°C

**HOW TO ORDER**

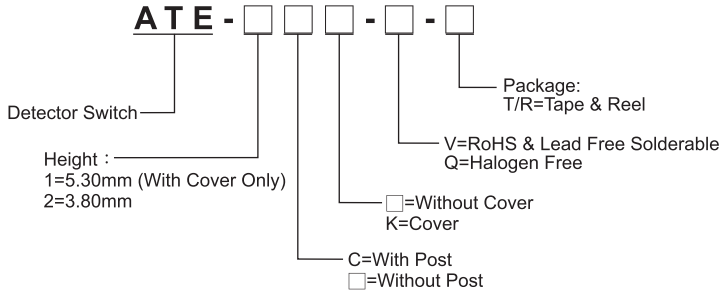

**CIRCUIT**

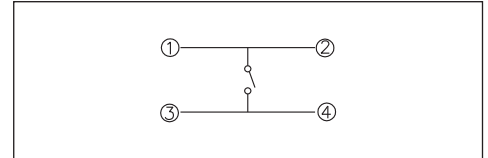

**PACKAGE**

<Tape & Reel>  
ATE-1   -T/R: 900 pcs  
ATE-2  K-T/R: 900 pcs  
ATE-2  -T/R: 1200 pcs

**ATE-1**

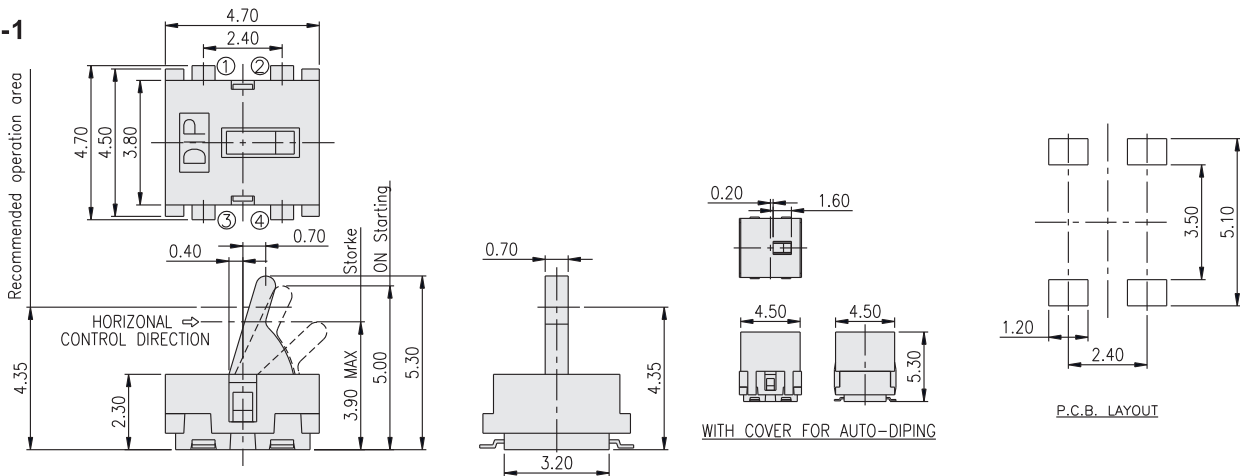

**ATE-2C**

