

Piezoresistive pressure transducer

Model 8540

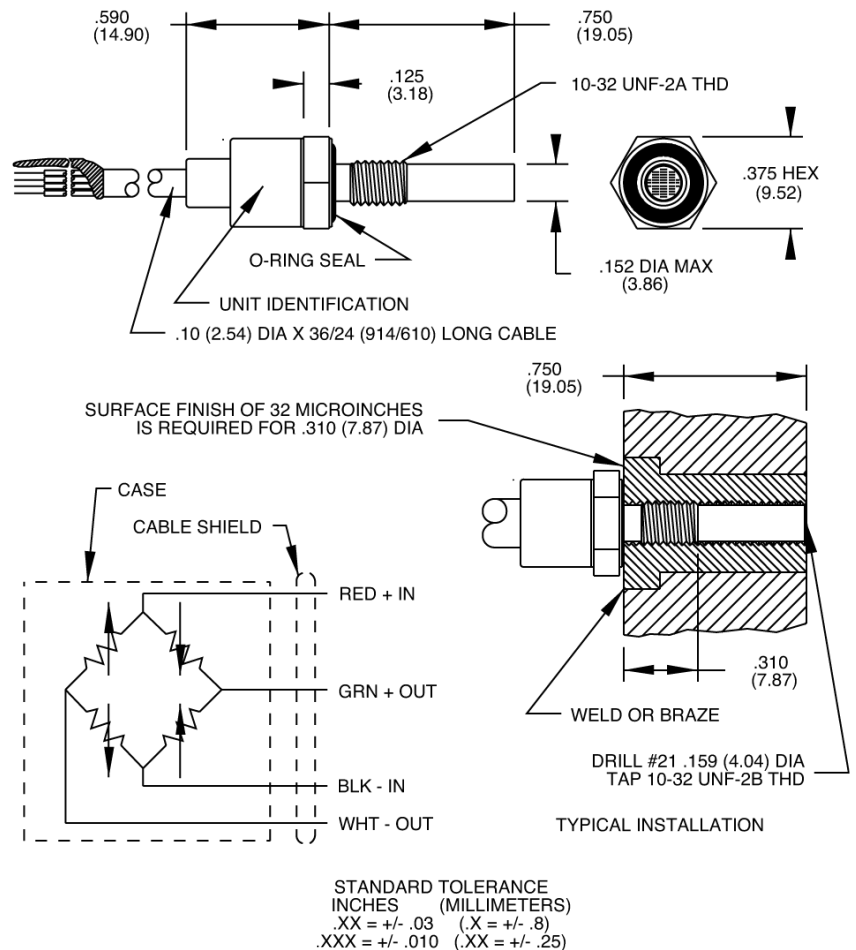
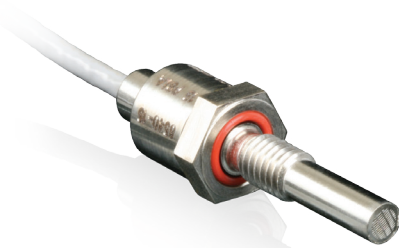

Key features

- 15, 50, 100, 200 and 500 psia ranges
- 300 mV full scale
- High temperature, +500°F (+260°C)
- Absolute reference

Description

Model 8540 is a rugged, miniature, high sensitivity piezoresistive absolute pressure transducer. The transducer has a 0.15 inch (3.8 mm) face diameter and is available in ranges from 15 to 500 psia. 8540 features high temperature performance to +500°F (+260°C) and can operate with diminished lifetime to +600°F (+316°C). Its excellent linearity combined with very high resonance makes it ideal for measuring dynamic pressure.

The transducer employs silicon strain gages bonded to a micro-machined silicon diaphragm for maximum sensitivity and wide frequency response. Internal sensitivity compensation and zero trim provides accuracy to +500°F (+260°C). This transducer exhibits low photo-flash sensitivity and high stability during temperature transients.

8540 is designed to measure static or dynamic pressures. Its small diameter suits it to flush mounting for measuring skin pressures on aircraft, inlet distortion pressures in turbine engines or transmission pressures in automobiles. The transducer's high frequency response permits use on small scale models in wind tunnels.

Recommended electronics for signal conditioning and power supply are model 126 and 136 general purpose three channel conditioners, ultra low noise 4430A conditioner, or the 4990A-X (Oasis) multi-channel rack mount system.

Piezoresistive pressure transducer

Model 8540

Specifications

The following performance specifications conform to ISA-RP-37.2 (1964) and are typical values, referenced at +75°F (+24°C) and 100 Hz, unless otherwise noted. Calibration data, traceable to National Institute of Standards and Technology (NIST), is supplied.

Dynamic characteristics	Units	-15	-50	-100	-200	-500
Range [1]	psia	0-15	0-50	0-100	0-200	0-500
Sensitivity [1]	mV/psi	20 +10/-6.7	6 +3/-2	3 +1.5/-1.0	1.5 +0.75/-0.5	0.6 +0.3/-0.2
Combined: non-linearity, non repeatability, pressure hysteresis [2]	% FSO RSS max	0.50	0.50	0.50	0.75	0.75
Non-linearity, independent	% FSO typ	0.25	0.25	0.25	0.4	0.4
Non-repeatability	% FSO typ	0.1	0.1	0.1	0.1	0.1
Pressure hysteresis	% FSO typ	0.1	0.1	0.1	0.1	0.1
Zero measurand output [3]	mV max	±20	±20	±20	±20	±20
Zero shift after 2X range	% 2X FSO max (typ)	0.2 (0.1)	0.2 (0.1)	0.2 (0.1)	0.2 (0.1)	0.2 (0.1)
Thermal zero shift						
From -30°F to 500°F (-34°C to +260°C) ref. to 75°F (24°C)	% FSO max	3.0	3.0	3.0	3.0	3.0
Thermal sensitivity shift						
From -30°F to 500°F (-34°C to +260°C) ref. to 75°F (24°C)	% max	4.0	4.0	4.0	4.0	4.0
Diaphragm resonance frequency	Hz (typ)	140 000	240 000	350 000	450 000	900 000
Non-linearity at 2X range	% 2X FSO (typ)	0.5	1.0	1.0	1.0	1.0
Zero shift with mounting torque 15 lbf-in.	% FSO (typ)	0.25	0.25	0.25	0.25	0.25
Thermal transient response per ISA-S37.10, PARA. 6.7, procedure I [4]	psi / °F (typ)	0.002	0.004	0.005	0.006	0.006
Photoflash response [5]	equiv psi	0.1	0.2	0.3	0.5	1.0
Warm-up time [6]	ms	1	1	1	1	1
Acceleration sensitivity	equiv. psi/g	0.0004	0.0003	0.0003	0.0007	0.0010
Burst pressure (diaphragm)	psia min	30	100	200	400	1000
Electrical						
Full scale output	300 +150/-100 mV at 10.0 Vdc					
Supply voltage [7]	10.0 Vdc recommended, 18 Vdc maximum					
Electrical configuration	Active four-arm piezoresistive bridge					
Polarity	Positive output for increasing pressure into (+) port					
Resistance						
Input	1600 ±900 ohms					
Output	800 ±500 ohms					
Isolation	100 megohms minimum at 50 Volts, leads to case, leads to shield, shield to case					
Noise	5 microvolts rms typical, DC to 50 000 Hz; 50 microvolts rms maximum, DC to 50 000 Hz					
Mechanical						
Case, material	Stainless steel (17-4 PH CRES)					
Cable, integral	Four conductor No. 30 AWG Teflon insulated conductors, braided shield, Teflon jacket					
Dead volume, measurand (+) port	0.0003 cubic inches (0.005 cc)					
Mounting/torque	10-32 UNF-2A threaded case 0.75 inch (19.05 mm) long / 15 ±5 lbf-in (1.7 ±0.6 Nm)					
Weight	8.5 grams (cable weighs 14 grams/meter)					
Environmental						
Media	Media in (+) port is exposed to stainless steel case, silicon diaphragm, ceramic, epoxy, RTV and fluorosilicone O-ring.					
Temperature [8]	-65°F to +500°F (-54°C to +260°C)					
Vibration / acceleration	300 g					
Shock	10 000 g, 100 microsecond half-sine					

Piezoresistive pressure transducer

Model 8540

Accessories

Product	Description	8540
EHR97	O-ring, fluorosilicone	Included
25045	Cable, 4 conductor	Optional

Notes

- 1 psi = 6.895 kPa = 0.069 bar.
- FSO (Full Scale Output) is defined as transducer output change from 0 psia to + full scale pressure.
- Zero Measurand Output (ZMO) is the transducer output with 0 psia applied.
- Significantly higher thermal transient errors occur if the excitation voltage exceeds 10 Vdc. For sensitive phase change studies, many users reduce the excitation to 5 Vdc or even 1 Vdc.
- The metal screen partially shields the silicon diaphragm from incident radiation. Accordingly, light incident at acute angles to the screen generally increases the error by a factor of 2 or 3.
- Warm-up time is defined as elapsed time from excitation voltage "turn on" until the transducer output is within $\pm 1\%$ of reading accuracy.
- Use of excitation voltages other than 10.0 Vdc requires manufacture and calibration at that voltage since thermal errors increase with high excitation voltages.
- 8540 can be operated at 500°F (260°C) continuously, at 550°F (288°C) for up to 24 hours and at 600°F (316°C) for up to 4 hours.
- Model number definition:

8540 - XXX - Y - ZZZ

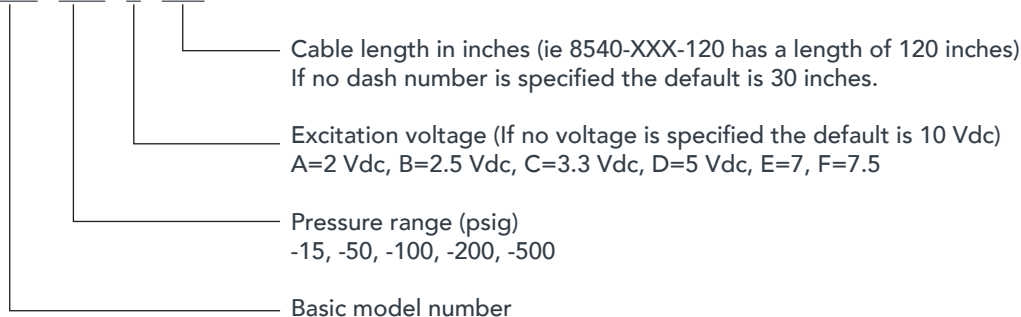

Other options

- M4 Gel
- M8 "A" screen, black grease

Ordering information

1. Maintain high levels of precision and accuracy using Endevco's factory calibration services. Call Endevco's inside sales force at 866-ENDEVCO for recommended intervals, pricing and turn-around time for these services as well as for quotations on our standard products.