

## DESCRIPTION

- Super bright LED Lamp
- Round type
- T-1 3mm diameter
- Lens color: Orange Transparent
- With Flange
- Solder leads without stand-off
- Compliant with RoHS

## FEATURES

- Emitted color: Super Amber
- High Luminous intensity
- Technology: AlGaInP
- Peak wavelength  $\lambda_p = 610\text{nm}$
- Viewing angle:  $20^\circ$

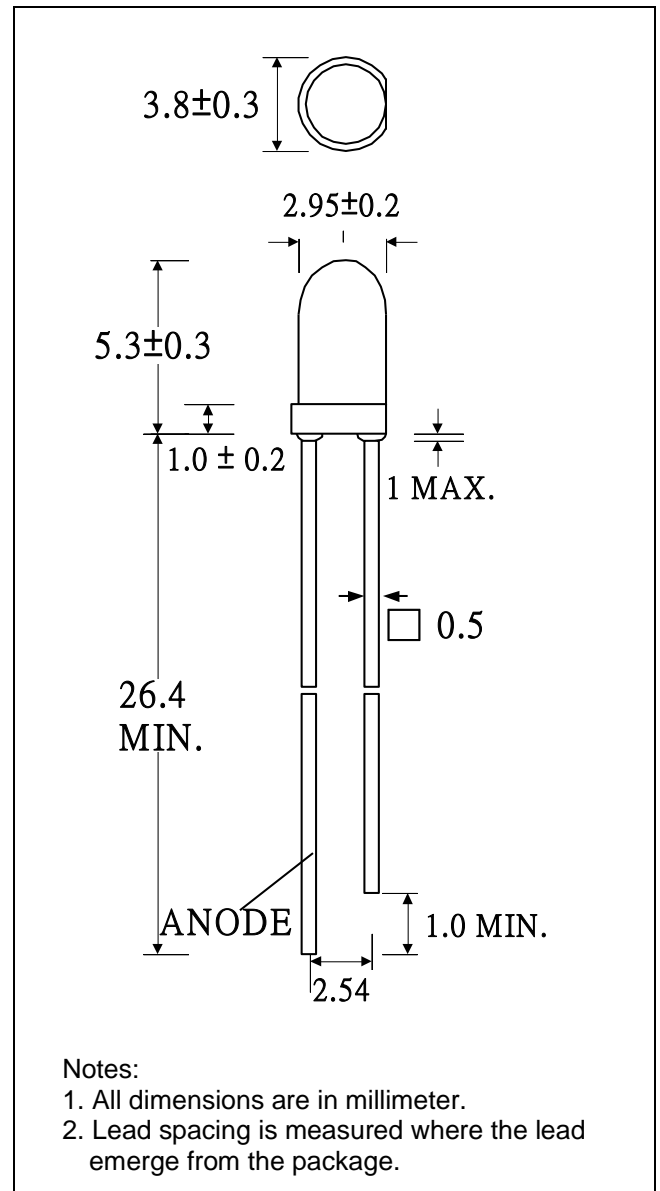

## SELECTION GUIDE

Chip Material	Chip Emitted	Lens Color	Viewing Angle
AlGaInP	Super Amber	Orange Transparent	$20^\circ$

Date	2019/08/21	Maker	Jay	Approver	J.C.Chi	Version	A	Page	1/3
------	------------	-------	-----	----------	---------	---------	---	------	-----

**ABSOLUTE MAXIMUM RATINGS**

(Ta=25°C)

PARAMETER	SYMBOL	MAX. RATING	Unit
Power Dissipation	$P_D$	60	mW
Peak Forward Current (1/10 Duty Cycle @1KHz )	$I_{FP}$	100	mA
Reverse Voltage	$V_R$	5.0	V
Operating Temperature Range	$T_{OPR}$	-40~+85	°C
Storage Temperature Range	$T_{STG}$	-40~+85	°C

Solder temperature 1.6 mm from body for 3 seconds at 260°C

**OPTICAL-ELECTRICAL CHARACTERISTICS**

PARAMETER	SYMBOL	TEST CONDITION	MIN	TYP	MAX	UNIT
Luminous Intensity	$I_V$	$I_F = 20mA$	1300	2000		mcd
Forward Voltage	$V_F$	$I_F = 20mA$		2.0	2.4	V
Reverse Current	$I_R$	$V_R = 5V$			10	uA
Viewing Angle	2θ1/2	$I_F = 20mA$		20		deg.
Peak Wavelength	$\lambda_P$	$I_F = 20mA$		610		nm
Dominant Wavelength	$\lambda_D$	$I_F = 20mA$		605		nm
Spectrum Radiation Bandwidth	$\Delta\lambda$	$I_F = 20mA$		20		nm

Date	2019/08/21	Maker	Jay	Approver	J.C.Chi	Version	A	Page	2/3
------	------------	-------	-----	----------	---------	---------	---	------	-----

**TYPICAL OPTICAL-ELECTRICAL CHARACTERISTIC CURVES**

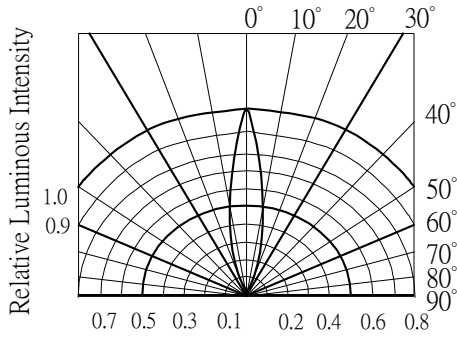

**RADIATION DIAGRAM**

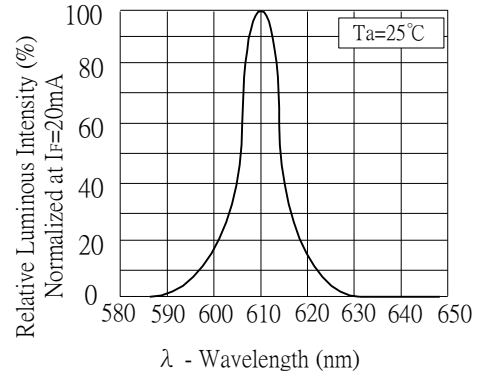

**RELATIVE LUMINOUS INTENSITY Vs. WAVELENGTH**

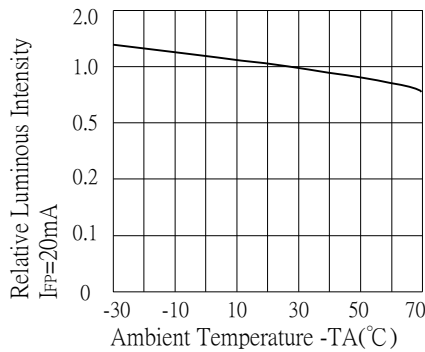

**LUMINOUS INTENSITY Vs. AMBIENT TEMPERATURE**

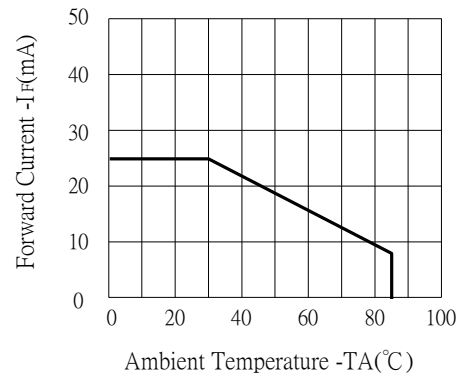

**MAX FORWARD CURRENT Vs. AMBIENT TEMPERATURE**

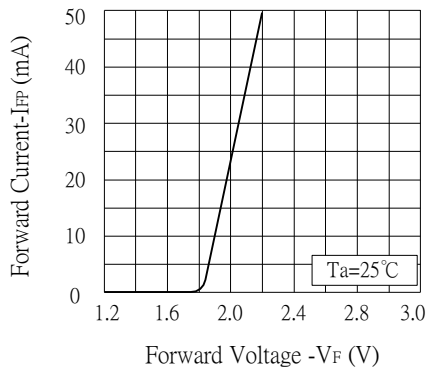

**FORWARD CURRENT Vs. FORWARD VOLTAGE**

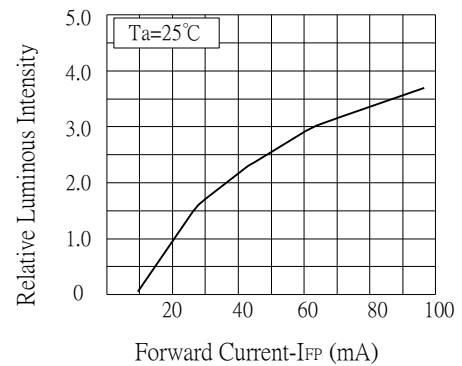

**LUMINOUS INTENSITY Vs. FORWARD CURRENT**

Date	2019/08/21	Maker	Jay	Approver	J.C.Chi	Version	A	Page	3/3
------	------------	-------	-----	----------	---------	---------	---	------	-----