

DC04S019JA1R600

Product Details

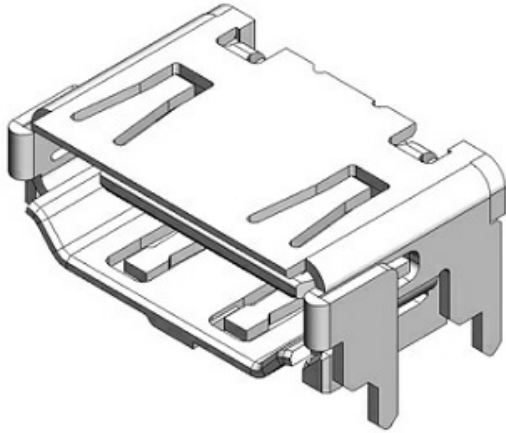

Part Number	DC04S019JA1R600
Status	Active
Features	HDMI 2.1 Specification Approved, Receptacle (Type A connector), Without flange, 19 pos., SMT, Shell DIP length: 1.9 mm
Number of Positions	19 pos.
Rated Current	0.5 A
Applicable Specifications	HDMI 2.1
Waterproof/ Non-waterproof	Non-waterproof
Applications	Audiovisual applications such as TV's, monitors, projectors, AV receivers and soundbars, set-top boxes, BD players, gaming system, digital cameras, graphics cards, and video boards
Connector Type	Receptacle
Connector Style	Right angle
PCB Mounting Type	On-board type
Flange	Without flange

Shell DIP Length	1.9 mm
Material of Insulator	Heat resisting plastic
Material of Contact	Copper alloy
Contact Finish	Gold plating over Nickel
Shell, Material/ Finish	Copper alloy/ Nickel plating
Packaging Type	Embossed tape packaging (600 pieces/reel)
Documents	<div style="display: flex; flex-wrap: wrap; gap: 10px;"> <div style="border: 1px solid #ccc; padding: 5px; margin: 5px;">Catalog ↓</div> <div style="border: 1px solid #ccc; padding: 5px; margin: 5px;">Drawings ↓</div> <div style="border: 1px solid #ccc; padding: 5px; margin: 5px;">Drawings ↓</div> <div style="border: 1px solid #ccc; padding: 5px; margin: 5px;">3D Models ></div> <div style="border: 1px solid #ccc; padding: 5px; margin: 5px;">PDF Download ↓</div> </div>
Stock Search	Stock Search >
RoHS compliant	10 substances (2011/65/EU)
REACH compliant	209 substances (25/06/2020)
Environment Information	RoHS/Reach Certificate >
Remarks	

Notice

1. The values specified in this web site are only for reference. The products and their specifications are subject to change without notice. Contact our sales staff for further information before considering or ordering any of our products.
For purchase, a product specification must be agreed upon.
2. Users are requested to provide protection circuits and redundancy circuits to ensure safety of the equipment, and sufficiently review the suitability of JAE's products to the equipment.

3. The products presented in this web site are designed for the uses recommended below.

We strongly suggest you contact our sales staff when considering use of any of the products in any other way than the recommended applications or for a specific use that requires an extremely high reliability.

(1) Applications that require consultation:

* Please contact us if you are considering use involving a quality assurance program that you specify or that is peculiar to the industry, such as:

Automotive electrical components, train control, telecommunications devices (mainline), traffic light control, electric power, combustion control, fire prevention or security systems, disaster evention equipment, etc.

* We may separately give you our support with a quality assurance program that you specify, when you think of a use such as :

Aviation or space equipment, submarine repeaters, nuclear power control systems, medical equipment for life support, etc.

(2) Recommended applications include:

* Computers, office appliances, telecommunications devices (terminals, mobile units), measuring equipment, audiovisual equipment, home electric appliances, factory automation equipment, etc