



# DVSA2800S Series

## HIGH RELIABILITY HYBRID DC-DC CONVERTERS

### DESCRIPTION

The DVSA series of high reliability DC-DC converters is operable over the full military (-55 °C to +125 °C) temperature range with no power derating. Unique to the DVSA series are robust and effective input and output filters which provide dramatically reduced input and output noise performance when compared to other manufacturers competing devices. Operating at a nominal fixed frequency of 450 kHz, these regulated, isolated units utilize a high speed magnetic feedback design and well controlled undervoltage lockout circuitry to eliminate slow start-up problems.

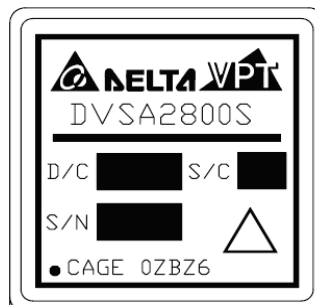
These converters are designed and manufactured in a facility qualified to ISO9001 and certified to MIL-PRF-38534 and MIL-STD-883.

This product may incorporate one or more of the following U.S. patents:

5,784,266  
5,790,389  
5,963,438  
5,999,433  
6,005,780  
6,084,792  
6,118,673

### FEATURES

- High Reliability
- Very Low Output Noise
- Wide Input Voltage Range: 15 to 50 Volts per MIL-STD-704
- Up to 6 Watts Output Power
- Fault Tolerant Magnetic Feedback Circuit
- NO Use of Optoisolators
- Undervoltage Lockout
- Indefinite Short Circuit Protection
- Current Limit Protection
- Industry Standard Pinout
- High Input Transient Voltage: 80 Volts for 1 sec per MIL-STD-704A
- Precision Projection Welded Hermetic Package
- High Power Density: > 19 W/in<sup>3</sup>
- Custom Versions Available
- Additional Environmental Screening Available
- Meets MIL-STD-461C and MIL-STD-461D EMC Requirements When Used With a DVMA28 EMI Filter
- MIL-PRF-38534 Element Evaluated Components
- Space Applications should consider VPT's "S" Series of Radiation Tolerant Power Conversion Devices. Contact VPT for details



**Figure 1** – DVSA2800S DC-DC Converter  
(Exact marking may differ from that shown)

## SPECIFICATIONS (T<sub>CASE</sub> = -55°C to +125°C, V<sub>IN</sub> = +28V ± 5%, Full Load, Unless Otherwise Specified)

### ABSOLUTE MAXIMUM RATINGS

Input Voltage (Continuous)	50 V <sub>DC</sub>	Junction Temperature Rise to Case	+10°C
Input Voltage (Transient, 1 second)	80 Volts	Storage Temperature	-65°C to +150°C
Output Power <sup>1</sup>	6 Watts	Lead Solder Temperature (10 seconds)	270°C
Power Dissipation (Full Load, T <sub>CASE</sub> = +125°C)	2.7 Watts	Weight (Maximum)	15 Grams
ESD Rating per MIL-PRF-38534	2		

Parameter	Conditions	DVSA283R3S			DVSA2805S			Units
		Min	Typ	Max	Min	Typ	Max	
<b>STATIC</b>								
INPUT Voltage <sup>4</sup>	Continuous	15	28	50	15	28	50	V
	Transient, 1 sec	-	-	80	-	-	80	V
Current	Inhibited	-	4	6	-	4	6	mA
	No Load	-	45	60	-	45	60	mA
Ripple Current	Full Load, 20Hz to 10MHz	-	25	50	-	30	50	mA <sub>p-p</sub>
Inhibit Pin Input <sup>4</sup>		0	-	1.5	0	-	1.5	V
Inhibit Pin Open Circuit Voltage <sup>4</sup>		9.0	11.0	13.0	9.0	11.0	13.0	V
UVLO Turn On		12.0	-	14.8	12.0	-	14.8	V
UVLO Turn Off <sup>4</sup>		11.0	-	14.5	11.0	-	14.5	V
OUTPUT Voltage	V <sub>OUT</sub> T <sub>CASE</sub> = 25°C	3.267	3.30	3.333	4.95	5.00	5.05	V
	V <sub>OUT</sub> T <sub>CASE</sub> = -55°C to +125°C	3.25	3.30	3.35	4.925	5.00	5.075	V
Power <sup>3</sup>		0	-	4	0	-	5	W
Current <sup>3</sup>	I <sub>OUT</sub>	0	-	1.21	0	-	1.0	A
Ripple Voltage	V <sub>OUT</sub> Full Load, 20Hz to 10MHz	-	10	30	-	10	30	mV <sub>p-p</sub>
Line Regulation	V <sub>OUT</sub> V <sub>IN</sub> = 15V to 50V	-	2	15	-	2	15	mV
Load Regulation	V <sub>OUT</sub> No Load to Full Load	-	20	50	-	15	50	mV
EFFICIENCY		62	65	-	65	68	-	%
LOAD FAULT POWER DISSIPATION	Overload <sup>4</sup>	-	-	3.3	-	-	3.3	W
	Short Circuit	-	-	3	-	-	3	W
CAPACITIVE LOAD <sup>4</sup>		-	-	1000	-	-	1000	μF
SWITCHING FREQUENCY		350	450	500	350	450	500	kHz
ISOLATION	500 V <sub>DC</sub>	100	-	-	100	-	-	MΩ
MTBF (MIL-HDBK-217F)	AIF @ T <sub>C</sub> = 55°C	-	457	-	-	457	-	kHrs
<b>DYNAMIC</b>								
Load Step Output Transient	V <sub>OUT</sub> Half Load to Full Load	-	200	300	-	200	500	mV <sub>PK</sub>
Load Step Recovery <sup>2</sup>		-	450	700	-	450	700	μSec
Line Step Output Transient <sup>4</sup>	V <sub>OUT</sub> V <sub>IN</sub> = 16V to 40V	-	250	500	-	350	700	mV <sub>PK</sub>
Line Step Recovery <sup>2, 4</sup>		-	600	1200	-	600	1200	μSec
Turn On Delay	V <sub>OUT</sub> V <sub>IN</sub> = 0V to 28V	-	10	20	-	10	20	mSec
Turn On Overshoot		-	0	15	-	0	25	mV <sub>PK</sub>

Notes: 1. Dependant on output voltage. 2. Time for output voltage to settle within 1% of its nominal value.  
 3. Derate linearly to 0 at 135°C. 4. Verified by qualification testing.

## SPECIFICATIONS (T<sub>CASE</sub> = -55°C to +125°C, V<sub>IN</sub> = +28V ± 5%, Full Load, Unless Otherwise Specified)

### ABSOLUTE MAXIMUM RATINGS

Input Voltage (Continuous)	50 V <sub>DC</sub>	Junction Temperature Rise to Case	+10°C
Input Voltage (Transient, 1 second)	80 Volts	Storage Temperature	-65°C to +150°C
Output Power <sup>1</sup>	6 Watts	Lead Solder Temperature (10 seconds)	270°C
Power Dissipation (Full Load, T <sub>CASE</sub> = +125°C)	2.7 Watts	Weight (Maximum)	15 Grams
ESD Rating per MIL-PRF-38534	2		

Parameter	Conditions	DVSA2812S			DVSA2815S			Units
		Min	Typ	Max	Min	Typ	Max	
<b>STATIC</b>								
INPUT Voltage <sup>4</sup>	Continuous	15	28	50	15	28	50	V
	Transient, 1 sec	-	-	80	-	-	80	V
Current	Inhibited	-	4	6	-	4	6	mA
	No Load	-	45	60	-	45	60	mA
Ripple Current	Full Load, 20Hz to 10MHz	-	30	50	-	30	50	mA <sub>p-p</sub>
Inhibit Pin Input <sup>4</sup>		0	-	1.5	0	-	1.5	V
Inhibit Pin Open Circuit Voltage <sup>4</sup>		9.0	11.0	13.0	9.0	11.0	13.0	V
UVLO Turn On		12.0	-	14.8	12.0	-	14.8	V
UVLO Turn Off <sup>4</sup>		11.0	-	14.5	11.0	-	14.5	V
OUTPUT Voltage	V <sub>OUT</sub> T <sub>CASE</sub> = 25°C	11.88	12.0	12.12	14.85	15.0	15.15	V
	V <sub>OUT</sub> T <sub>CASE</sub> = -55°C to +125°C	11.82	12.0	12.18	14.775	15.0	15.225	V
Power <sup>3</sup>		0	-	6	0	-	6	W
Current <sup>3</sup>	I <sub>OUT</sub>	0	-	0.5	0	-	0.4	A
Ripple Voltage	V <sub>OUT</sub> Full Load, 20Hz to 10MHz	-	10	30	-	10	30	mV <sub>p-p</sub>
Line Regulation	V <sub>OUT</sub> V <sub>IN</sub> = 15V to 50V	-	2	15	-	2	15	mV
Load Regulation	V <sub>OUT</sub> No Load to Full Load	-	5	50	-	5	50	mV
EFFICIENCY		71	76	-	72	78	-	%
LOAD FAULT POWER DISSIPATION	Overload <sup>4</sup>	-	-	3	-	-	3	W
	Short Circuit	-	-	3	-	-	3	W
CAPACITIVE LOAD <sup>4</sup>		-	-	500	-	-	500	μF
SWITCHING FREQUENCY		350	450	500	350	450	500	kHz
ISOLATION	500 V <sub>DC</sub>	100	-	-	100	-	-	MΩ
MTBF (MIL-HDBK-217F)	AIF @ T <sub>C</sub> = 55°C	-	457	-	-	457	-	kHrs
<b>DYNAMIC</b>								
Load Step Output Transient	V <sub>OUT</sub> Half Load to Full Load	-	300	700	-	300	700	mV <sub>PK</sub>
Load Step Recovery <sup>2</sup>		-	200	400	-	200	400	μSec
Line Step Output Transient <sup>4</sup>	V <sub>OUT</sub> V <sub>IN</sub> = 16V to 40V	-	700	1200	-	700	1300	mV <sub>PK</sub>
Line Step Recovery <sup>2, 4</sup>		-	200	600	-	200	600	μSec
Turn On Delay	V <sub>OUT</sub> V <sub>IN</sub> = 0V to 28V	-	10	20	-	10	20	mSec
Turn On Overshoot		-	0	50	-	0	50	mV <sub>PK</sub>

Notes: 1. Dependant on output voltage. 2. Time for output voltage to settle within 1% of its nominal value.  
 3. Derate linearly to 0 at 135°C. 4. Verified by qualification testing.

## SPECIFICATIONS (T<sub>CASE</sub> = -55°C to +125°C, V<sub>IN</sub> = +28V ± 5%, Full Load, Unless Otherwise Specified)

### ABSOLUTE MAXIMUM RATINGS

Input Voltage (Continuous)	50 V <sub>DC</sub>	Junction Temperature Rise to Case	+10°C
Input Voltage (Transient, 1 second)	80 Volts	Storage Temperature	-65°C to +150°C
Output Power <sup>1</sup>	6 Watts	Lead Solder Temperature (10 seconds)	270°C
Power Dissipation (Full Load, T <sub>CASE</sub> = +125°C)	2.7 Watts	Weight (Maximum)	15 Grams
ESD Rating per MIL-PRF-38534	2		

Parameter	Conditions	DVSA285R2S			Units
		Min	Typ	Max	
<b>STATIC</b>					
INPUT Voltage <sup>4</sup>	Continuous	15	28	50	V
	Transient, 1 sec	-	-	80	V
Current	Inhibited	-	4	6	mA
	No Load	-	45	60	mA
Ripple Current	Full Load, 20Hz to 10MHz	-	30	50	mA <sub>p-p</sub>
Inhibit Pin Input <sup>4</sup>		0	-	1.5	V
Inhibit Pin Open Circuit Voltage <sup>4</sup>		9.0	11.0	13.0	V
UVLO Turn On		12.0	-	14.8	V
UVLO Turn Off <sup>4</sup>		11.0	-	14.5	V
OUTPUT Voltage	V <sub>OUT</sub> T <sub>CASE</sub> = 25°C	5.148	5.20	5.252	V
	V <sub>OUT</sub> T <sub>CASE</sub> = -55°C to +125°C	5.122	5.20	5.278	V
Power <sup>3</sup>		0	-	5.2	W
Current <sup>3</sup>	I <sub>OUT</sub>	0	-	1.0	A
Ripple Voltage	V <sub>OUT</sub> Full Load, 20Hz to 10MHz	-	10	30	mV <sub>p-p</sub>
Line Regulation	V <sub>OUT</sub> V <sub>IN</sub> = 15V to 50V	-	2	15	mV
Load Regulation	V <sub>OUT</sub> No Load to Full Load	-	15	50	mV
EFFICIENCY		65	68	-	%
LOAD FAULT POWER DISSIPATION	Overload <sup>4</sup>	-	-	3.3	W
	Short Circuit	-	-	3	W
CAPACITIVE LOAD <sup>4</sup>		-	-	1000	μF
SWITCHING FREQUENCY		350	450	500	kHz
ISOLATION	500 V <sub>DC</sub>	100	-	-	MΩ
MTBF (MIL-HDBK-217F)	AIF @ T <sub>C</sub> = 55°C	-	457	-	kHrs
<b>DYNAMIC</b>					
Load Step Output Transient	V <sub>OUT</sub> Half Load to Full Load	-	200	500	mV <sub>PK</sub>
Load Step Recovery <sup>2</sup>		-	450	700	μSec
Line Step Output Transient <sup>4</sup>	V <sub>OUT</sub> V <sub>IN</sub> = 16V to 40V	-	350	700	mV <sub>PK</sub>
Line Step Recovery <sup>2, 4</sup>		-	600	1200	μSec
Turn On Delay	V <sub>OUT</sub> V <sub>IN</sub> = 0V to 28V	-	10	20	mSec
Turn On Overshoot		-	0	25	mV <sub>PK</sub>

Notes: 1. Dependant on output voltage. 2. Time for output voltage to settle within 1% of its nominal value.  
 3. Derate linearly to 0 at 135°C. 4. Verified by qualification testing.

**BLOCK DIAGRAM**

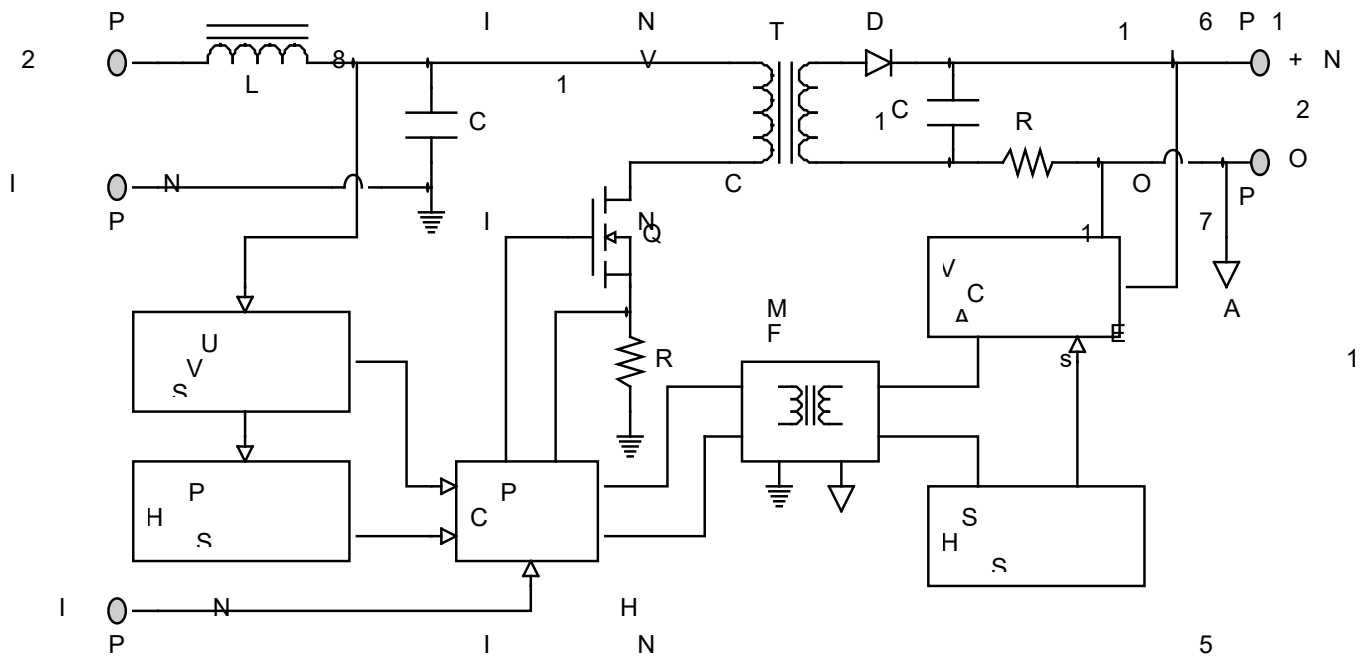


Figure 2

**CONNECTION DIAGRAM**

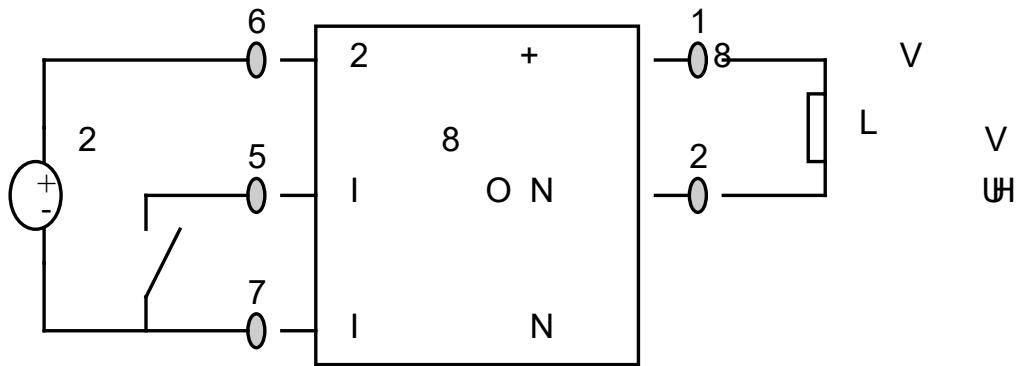
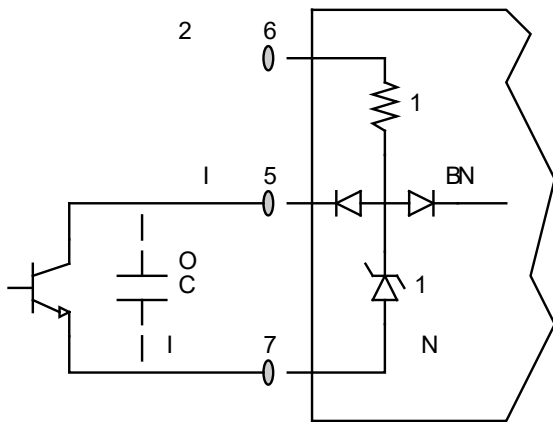
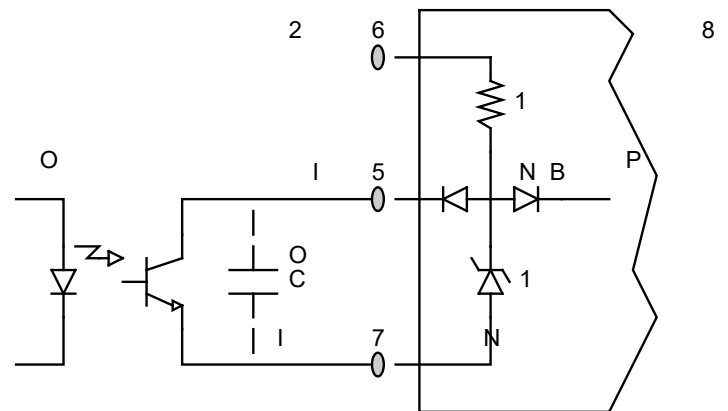


Figure 3

**INHIBIT DRIVE CONNECTION DIAGRAMS**

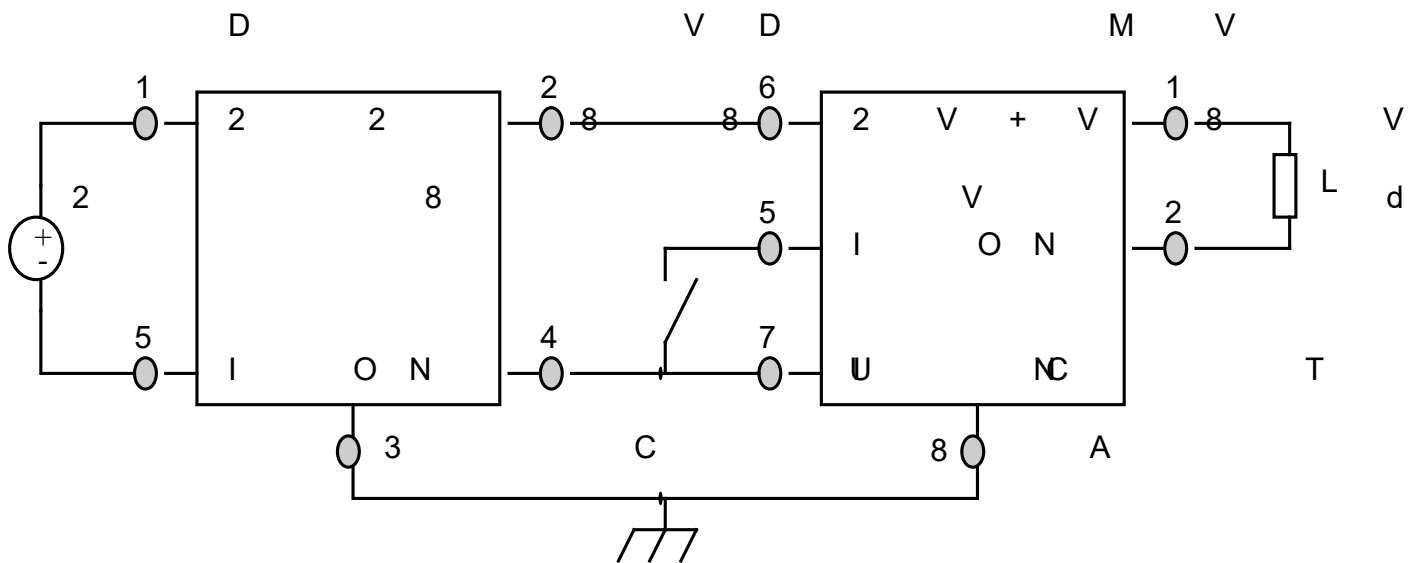


**Figure 4** – Internal Inhibit Circuit and Recommended Drive  
(Shown with optional capacitor for turn-on delay)



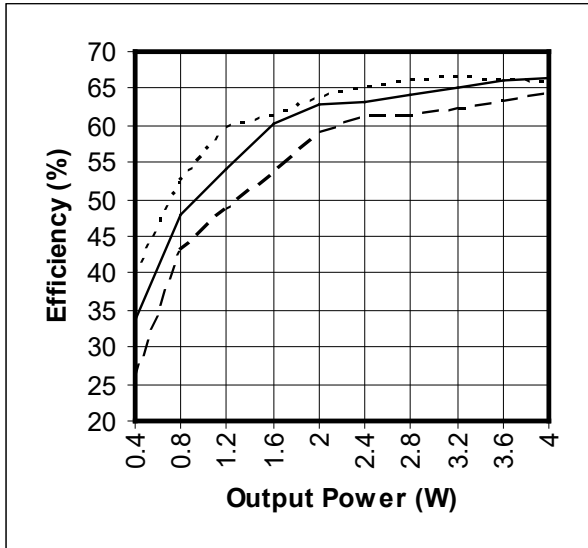
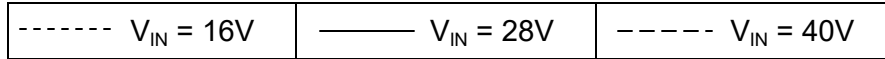
**Figure 5** – Isolated Inhibit Drive  
(Shown with optional capacitor for turn-on delay)

**EMI FILTER HOOKUP DIAGRAM**

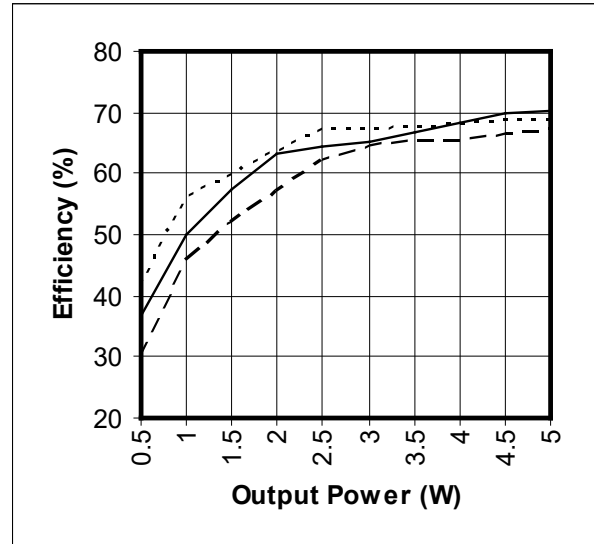


**Figure 6** – Converter with EMI Filter

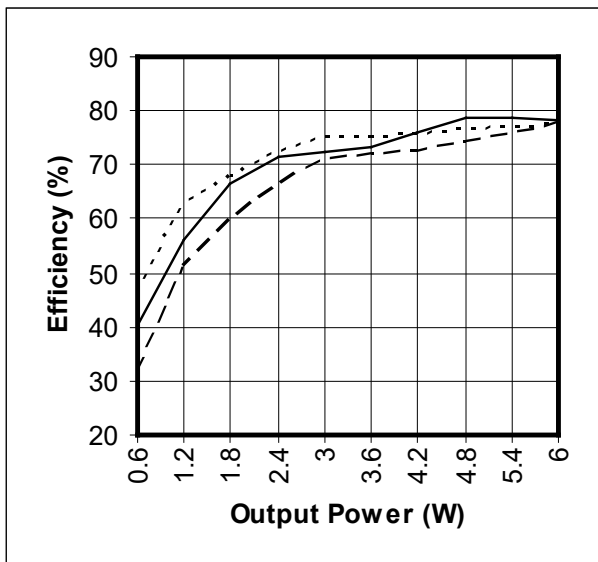
**EFFICIENCY PERFORMANCE CURVES** ( $T_{CASE} = 25^{\circ}C$ , Full Load, Unless Otherwise Specified)



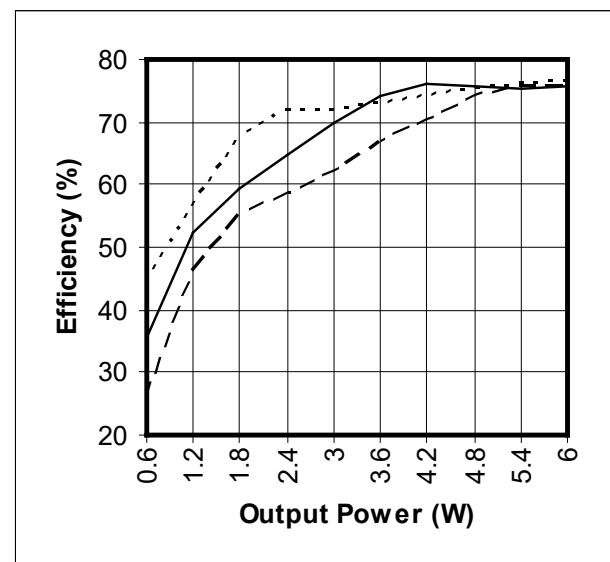
**Figure 7 – DVSA283R3S**  
 Efficiency (%) vs. Output Power (W)



**Figure 8 – DVSA2805S / DVSA285R2S**  
 Efficiency (%) vs. Output Power (W)



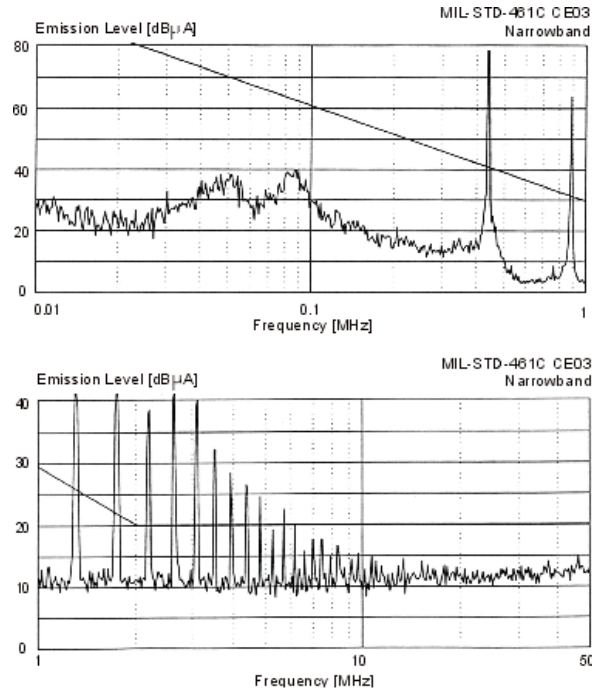
**Figure 9 – DVSA2812S**  
 Efficiency (%) vs. Output Power (W)



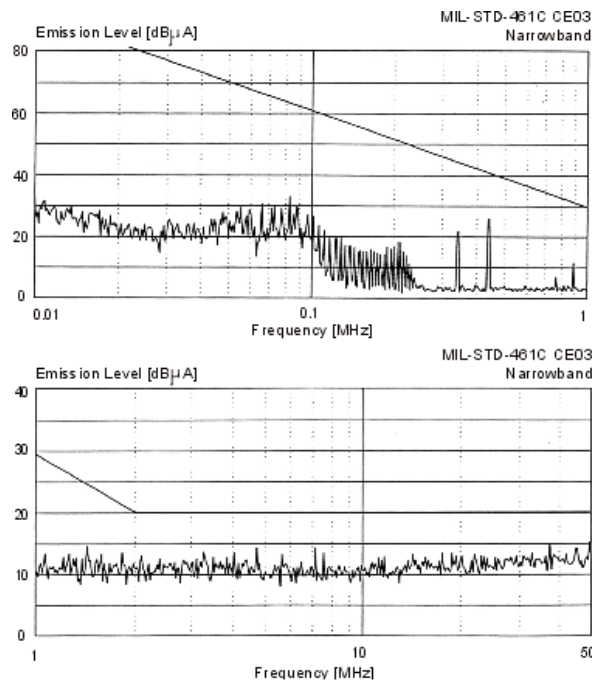
**Figure 10 – DVSA2815S**  
 Efficiency (%) vs. Output Power (W)

**EMI PERFORMANCE CURVES**

( $T_{CASE} = 25^{\circ}C$ ,  $V_{IN} = +28V \pm 5\%$ , Full Load, Unless Otherwise Specified)



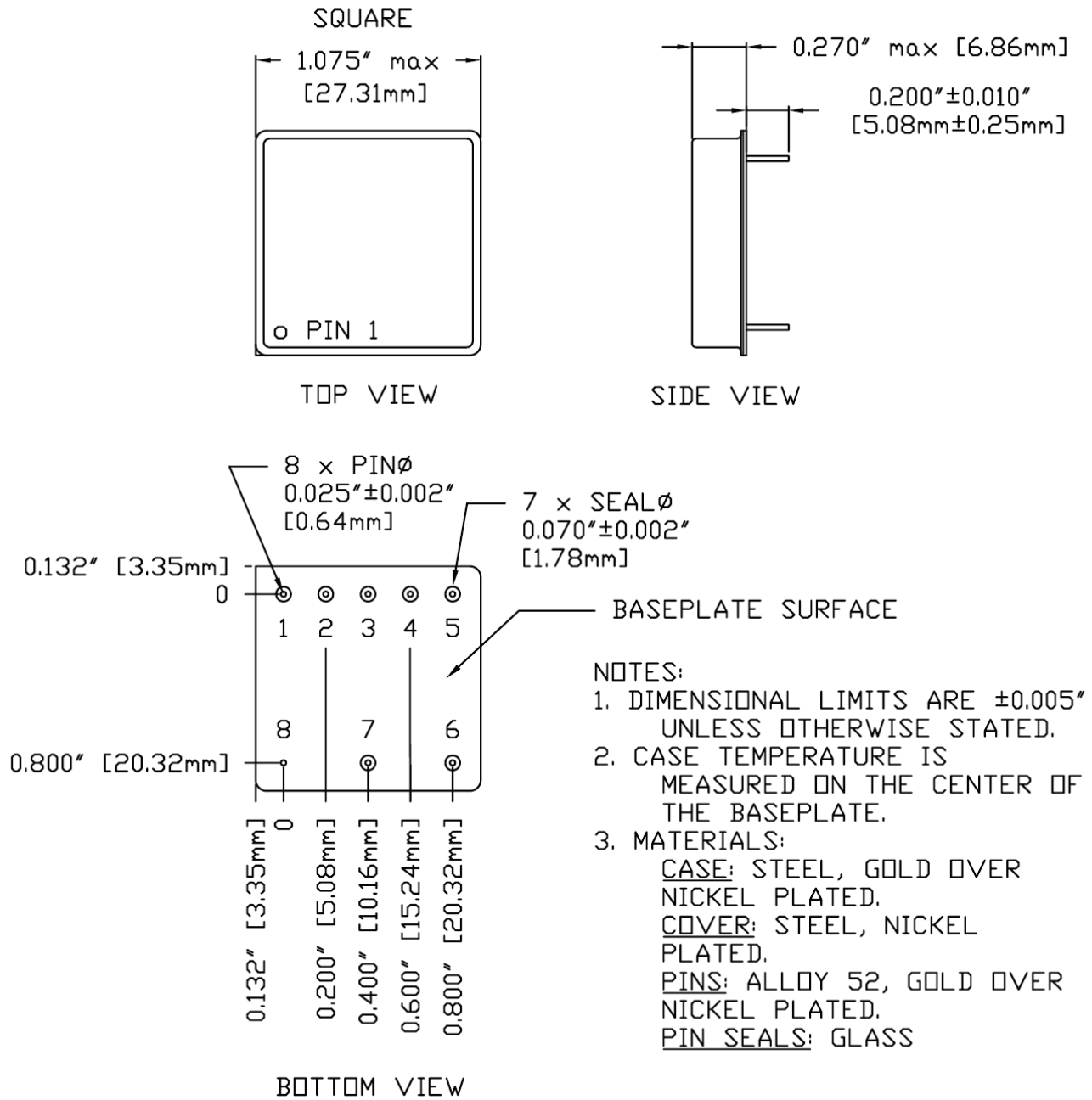
**Figure 11 – DVSA2800S without EMI Filter**



**Figure 12 – DVSA2800S with EMI Filter**



**PACKAGE SPECIFICATIONS**



Pin	Function	Pin	Function
1	+V OUT	5	INHIBIT
2	OUT COM	6	28V IN
3	N/C	7	IN COM
4	N/C	8	CASE

**Figure 13 – Package and Pinout**

## PACKAGE PIN DESCRIPTION

Pin	Function	Description
1	+V OUT	Positive Output Voltage Connection
2	OUT COM	Output Common Connection
3	N/C	No Connection
4	N/C	No Connection
5	INHIBIT	Logic Low = Disabled Output. Connecting the inhibit pin to input common causes converter shutdown. Logic High = Enabled Output. Unconnected or open collector TTL.
6	28V IN	Positive Input Voltage Connection
7	IN COM	Input Common Connection
8	CASE	Case Connection

## ENVIRONMENTAL SCREENING (100% Tested Per MIL-STD-883 as referenced to MIL-PRF-38534)

Screening	MIL-STD-883	Standard (No Suffix)	Extended /ES	HB /HB	Class H /H	Class K /K
Non-Destructive Bond Pull	Method 2023	•	•	•	•	•
Internal Visual	Method 2017, 2032 Internal Procedure	•	•	•	•	•
Temperature Cycling	Method 1010, Condition C Method 1010, -55°C to 125°C		•	•	•	•
Constant Acceleration	Method 2001, 3000g, Y1 Direction Method 2001, 500g, Y1 Direction		•	•	•	•
PIND	Method 2020, Condition A <sup>2</sup>					•
Pre Burn-In Electrical	100% at 25°C					•
Burn-In	Method 1015, 320 hours at +125°C Method 1015, 160 hours at +125°C 96 hours at +125°C 24 hours at +125°C	•	•	•	•	•
Final Electrical	MIL-PRF-38534, Group A <sup>1</sup> 100% at 25°C	•	•	•	•	•
Hermeticity	Method 1014, Fine Leak, Condition A Method 1014, Gross Leak, Condition C Dip ( $1 \times 10^{-3}$ )	•	•	•	•	•
Radiography	Method 2012 <sup>3</sup>					•
External Visual	Method 2009	•	•	•	•	•

- Notes:
1. 100% R&R testing at -55°C, +25°C, and +125°C with all test data included in product shipment.
  2. PIND test Certificate of Compliance included in product shipment.
  3. Radiographic test Certificate of Compliance and film(s) included in product shipment.

## ORDERING INFORMATION

DVSA	28	05	S	/HB	-	XXX
1	2	3	4	5		6

(1) Product Series	(2) Nominal Input Voltage		(3) Output Voltage		(4) Number of Outputs	
DVSA	28	28 Volts	3R3 05 5R2 12 15	3.3 Volts 5 Volts 5.2 Volts 12 Volts 15 Volts	S	Single

(5) Screening Code <sup>1,2</sup>		(6) Additional Screening Code
None /ES /HB /H /K	Standard Extended HB Class H Class K	Contact Sales

- Notes:
1. Contact the VPT Inc. Sales Department for availability of Class H (/H) or Class K (/K) qualified products.
  2. VPT Inc. reserves the right to ship higher screened or SMD products to meet lower screened orders at our sole discretion unless specifically forbidden by customer contract.

Please contact your sales representative or the VPT Inc. Sales Department for more information concerning additional environmental screening and testing, different input voltage, output voltage, power requirement, source inspection, and/or special element evaluation for space or other higher quality applications.

## SMD (STANDARD MICROCIRCUIT DRAWING) NUMBERS

Standard Microcircuit Drawing (SMD)	DVSA2800S Series Similar Part Number
5962-0324101HXC	DVSA283R3S/H
5962-0324102HXC	DVSA2805S/H
5962-0324103HXC	DVSA285R2S/H
5962-0324104HXC	DVSA2812S/H
5962-0324105HXC	DVSA2815S/H

Do not use the DVSA2800S Series similar part number for SMD product acquisition. It is listed for reference only. For exact specifications for the SMD product, refer to the SMD drawing. SMD's can be downloaded from the DLA Land and Maritime (Previously known as DSCC) website at <https://landandmaritimeapps.dla.mil/programs/defaultapps.asp>. The SMD number listed above is for MIL-PRF-38534 Class H screening, standard gold plated lead finish, and no RHA (Radiation Hardness Assurance) level. Please reference the SMD for other screening levels, lead finishes, and radiation levels. All SMD products are marked with a "Q" on the cover as specified by the QML certification mark requirement of MIL-PRF-38534.

## CONTACT INFORMATION

To request a quotation or place orders please contact your sales representative or the VPT Inc. Sales Department at:

**Phone:** (425) 353-3010  
**Fax:** (425) 353-4030  
**E-mail:** [vptsales@vpt-inc.com](mailto:vptsales@vpt-inc.com)

All information contained in this datasheet is believed to be accurate, however, no responsibility is assumed for possible errors or omissions. The products or specifications contained herein are subject to change without notice.