

# PRODUCTION SPECIFICATION

CUSTOMER	IBS	PRODUCTION	T13.8*10*8.5	DATE	5/22/2020
1.DIMENSION (UNIT: mm)				NO.	HJ-L1928

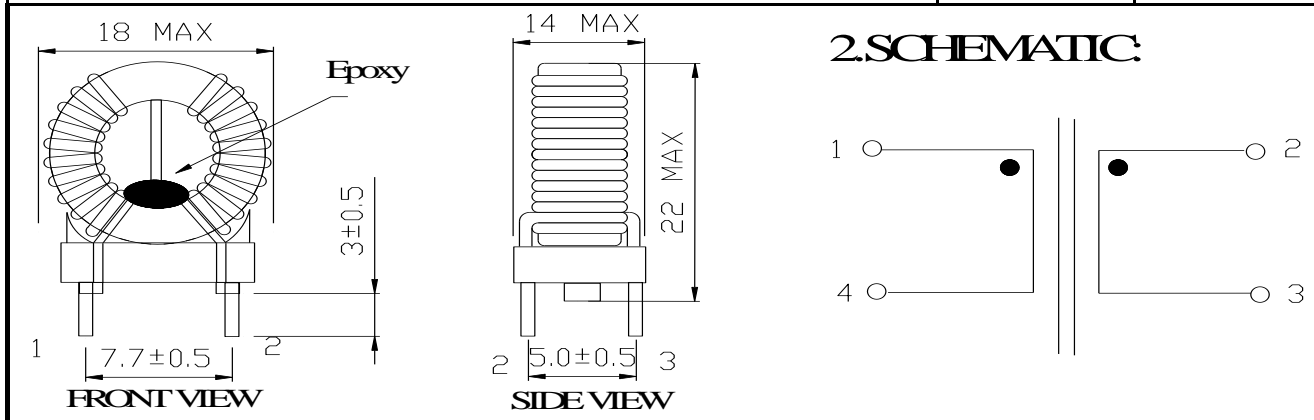

### 3.ELECTRONIACS,WIRE&TURNS(AT:10KHz 0.1mA Internal Resistance of instrument100

WINDING	START	FINISH	WIRE (mm)	TURN (TS)	INDUCTANCE	DCR
N1	1	4	0.3Φ*1C N 1UEW	51.5 REF	80mH+50%/-30%	1000mΩ MAX
N2	2	3	0.3Φ*1C N 1UEW	51.5 REF	80mH+50%/-30%	1000mΩ MAX
HI-POT			COIL-COIL		AC 500V/5mA/60S	
INSULATION RESLATANCE			COIL-COIL		DC 500V/100MOHM MIN	

Test instrument will be HT2820 of TongHui or HY-7221 of HuaYi or equivalent

### 4.MATERIAL LIST

ITEM	MATERIAL	SUPPLER	UL
CORE	T13.8*10*8.5-C	DongGuan HangJin Electronics Co., Ltd	
WIRE	1UEW 130°C	TAI-I COPPER(GUANZHOU)CO., LTD	E234896
SN	SNCU	DONGGUAN BEST ALLOYS CO., LTD	
EPOXY	BLACK EPOXY E-500(XX)	DONGGUAN EATTO ELECTRONIC MATERIAL CO LTD	E218090
VARNISH	T4260	SUZHOU TAIHU ELECTRIC ADVANCED MATERIAL CO LTD	E228349

Note: 1. the finished product must be impregnated; 2. lead-free processing; 3. Add Partition Board in the middle and fix it with glue; 4. A base is arranged at the bottom of the coil(as shown)

APPROVER: Song Jian Ping      CHECK: Song Li Xia      ADMIT: Tony

