



CM & RAW-1

TRIP CIRCUIT MONITORS

IMPROVE PROTECTIVE SYSTEM RELIABILITY THROUGH...

- Continuous monitoring of trip coil continuity
- LED indication of open trip circuits
- N.O. or N.C. contact for remote indication of open trip coils.
- Self-monitoring — long-life
- Can also be used as a self-latching, high speed target for trip indication
- UL Recognized 
- RoHS Compliant (Directive 2002/95/EC)

The RAW-1 and the CM are panel mounted relays containing a series LED for visual indication and blocking diodes for prevention of alarm indication when the breaker is opened. If a trip coil or auxiliary trip relay coil opens, the LED goes out and the relay is deenergized. The relay itself is self-monitoring since opening of any of the series components causes the same conditions as the loss of the trip coil. On breaker opening, the RAW-1 is energized through the breaker “B” contact. The time delay auxiliary relay does not time out.

The CM acts as a continuous monitor of the breaker position and the trip coil.

The RAW-1 is connected to supply monitoring through indication and alarm contacts for security. When a remote alarm is received, the unlit LED identifies the open circuit. Loss of the trip bus voltage is also signaled by a contact operation.

The RAW-1D and the CMD contain the additional feature of delayed drop-out. The delay of approximately 200 milliseconds is designed to allow auxiliary contacts to transfer.

The RAW-1, RAW -1D, CM and CMD are designed with auxiliary resistors and diodes for easy addition to existing installations. The output contact is a one form C. All units come with a red LED as standard. Amber, green, blue, white and yellow LEDs are also available.

The LED is plug-in replaceable and has a life of over 100,000 hours. The LED is protected against accidental reverse polarity application by a diode.

To ease panel layout, E-MAX designed the LED Indicator Assembly. Housed in the same chassis as the RAW and CM series relays, the Assembly functions as a simple indicator lamp. The LED Indicator Assembly is available for 125 Vdc, 48 Vdc, 250 Vdc, and 120 Vac input. Like the RAW and CM relays, the LED Indicator Assembly comes with red as the default LED color. Amber, green, blue, white and yellow LED's may be substituted.

APPLICATION AND SCHEMATICS

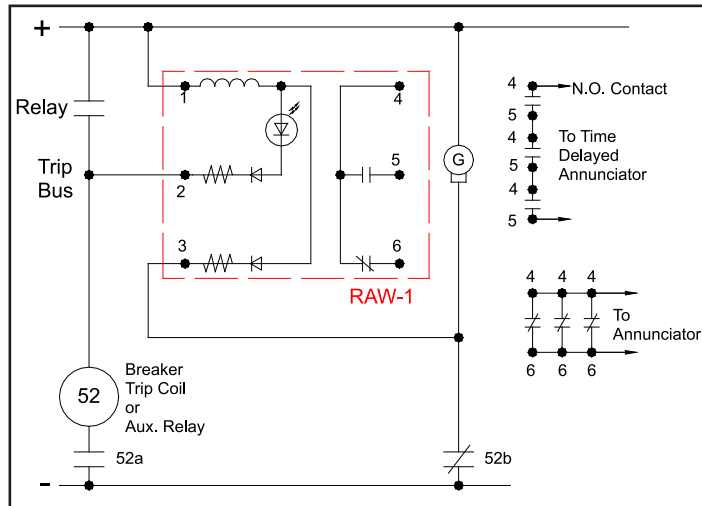

ALSO SEE RAW-1 RELAY AND RAW-1D SCHEMATIC ON PAGE 3

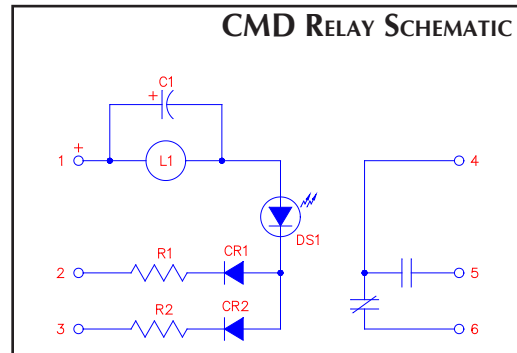
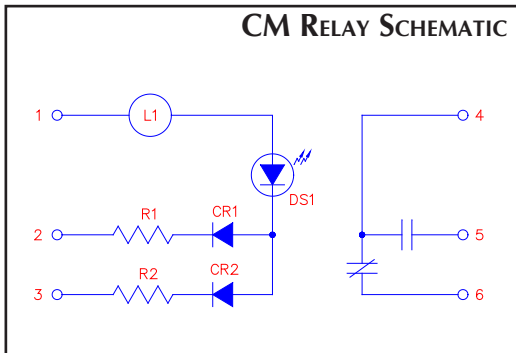

DIMENSIONS

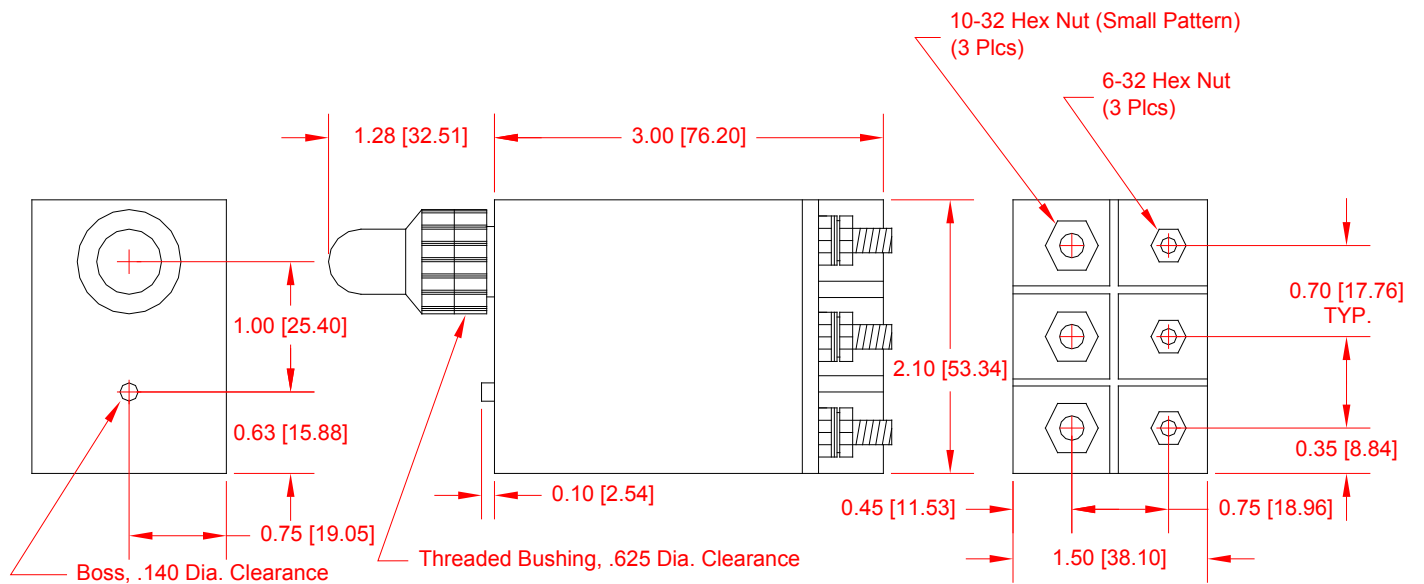

Maximum Panel Thickness, .218.

E-MAX has received inquiries regarding the availability of an AC-operated version of the Type RAW relay. While the presence of the blocking diodes in the RAW circuitry (see Figure 1) will protect the LED from damage if AC voltage is applied (the blocking diode will function as a half-wave rectifier), the operation speed of the relay would cause it to operate and release once every half cycle at any frequency below about 170 Hz, depending of the tolerances of each relay.

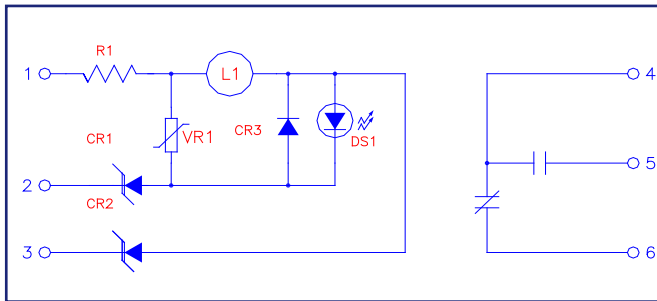

Figure 1 - RAW-1

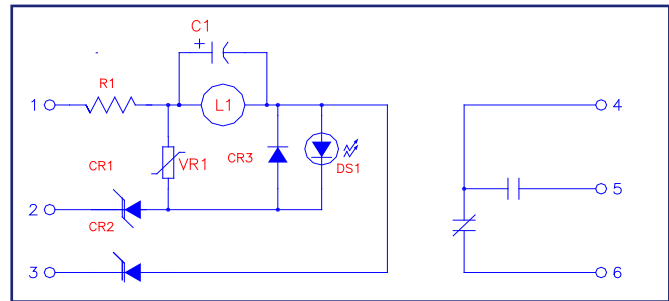

Figure 2 - RAW-1D

This problem is eliminated in the E-MAX Type RAW-1D relay. The RAW-1D is identical to the Type RAW-1, except that a 30 uF capacitor has been added in parallel with the relay coil (Figure 2). The original purpose of this capacitor was to provide a delay in the dropout of the relay. The 30 uF value provides a release delay of about 200 ms in the DC-operated relays. The presence of this capacitor, in conjunction with the blocking diodes, forms a circuit similar to a half-wave linear power supply, with the relay coil as the load. The result is that a DC voltage is applied to the relay coil, and the relay operates in the same manner, whether energized by AC or DC voltage.



E-MAX has tested the RAW-1D on AC power, and the relay type functions properly in all respects. The AC characteristics of the Type RAW-1D (P/N 632A304, 125Vdc) are:

Device Resistance	$\approx 15000 \Omega$
Operate Time	$2\text{ms} \leq t_{\text{operate}} \leq 12\text{ms}^{(1)}$
Release Time	$150\text{ms} \geq t_{\text{release}} \leq 200\text{ms}^{(2)}$
Minimum Operate Voltage	90Vac ⁽³⁾
Dropout Voltage	90Vac ⁽³⁾

- (1) Operate time will vary depending upon the instantaneous voltage of the AC power at the instant the relay is energized; operation will be delayed if the instantaneous voltage is below the minimum operate voltage.
- (2) Release time will vary with the voltage applied; delay will be reduced if applied voltage is reduced.
- (3) These voltages are typical, but are not specifications of the Type RAW-1D relay, and may vary somewhat with component and production tolerances.

ORDER INFORMATION

RAW-1 & RAW-1D



Part No.	Model	Nominal	Minimum	Nominal Resistance	UL Recognized*
632A301	RAW-1	125 V	90 V	15 K	
632A302	RAW-1	48 V	30 V	6.5 K	
632A303	RAW-1	250 V	175 V	35 K	
632A308	RAW-1	24 V	15 V		
632A304	RAW-1D	125 V	90 V	15 K	
632A305	RAW-1D	48 V	30 V	6.5 K	
632A306	RAW-1D	250 V	175 V	35 K	
632A307	RAW-1D	24 V	15 V		

For AC Applications, select the RAW-1D Series

LED INDICATOR ASSEMBLY

Part No.	Model	Nominal
632A401	LED Assembly	125 Vdc
632A402	LED Assembly	48 Vdc
632A403	LED Assembly	120 Vac
632A404	LED Assembly	250 Vdc

CM & CMD

Part No.	Model	Nominal	Minimum	Nominal Resistance	UL Recognized
632A501	CM	125 Vdc	90 V	15 K	
632A502	CM	48 Vdc	30 V	6.5 K	
632A503	CM	250 Vdc	175 V	35 K	
632A504	CMD	125 Vdc	90 V	15 K	
632A505	CMD	48 Vdc	30 V	6.5 K	
632A506	CMD	250 Vdc	175 V	35 K	

CIRCUIT MONITORS WITHOUT LED INDICATION

632A514	CMD	125 Vdc	90V	15 K	
632A515	CMD	48 Vdc	30V	6.5 K	

Isolation	1500 Vdc minimum contact to coil or coil to ground.
Contact Rating	Switching - 50 Watts 1.5 A max.; 500 V max. Carrying - 3.2 A max.
Operating Temperature	-25 to 65° C
Storage Temperature	-54 to 85° C
Altitude	0 - 50,000 feet
Life Expectancy	1 x 10 ⁵ Operations
Vibration	Insensitive to Vibration below 1 KHz
Noise Immunity	ANSI C37.90a-1974
Cycling Rate	60 cps Maximum

When ordering specify Part Number and LED color. Example 632A301-Yellow

Default LED color: Red

Standard Colors available: Amber, Yellow, Green, Blue, White

Note: The blue LED appears clear when not illuminated. There is an additional charge for White LEDs. Cluster LEDs are no longer available.

* UL Certificate Number - NKCR2.E322922 For Canada - NKCR8.E322922

