

REVISIONS				
P	LTR	DESCRIPTION	DATE	APPD
N		REVISED PER ECO-15-015252	13NOV15	BJ FY

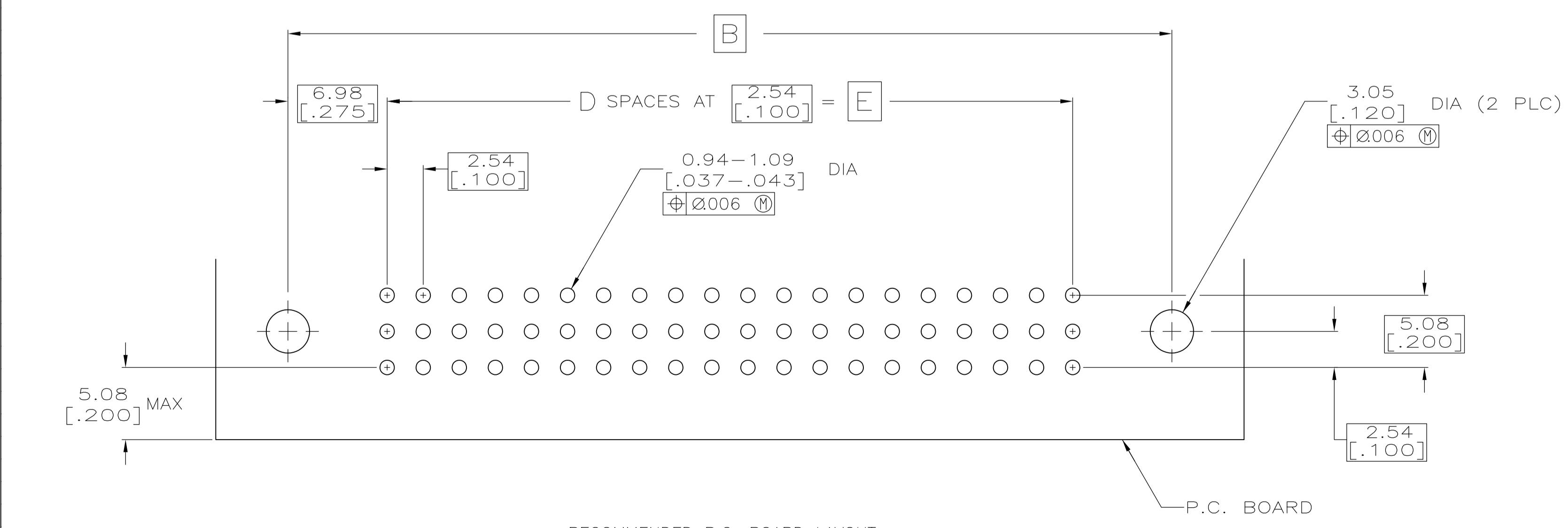
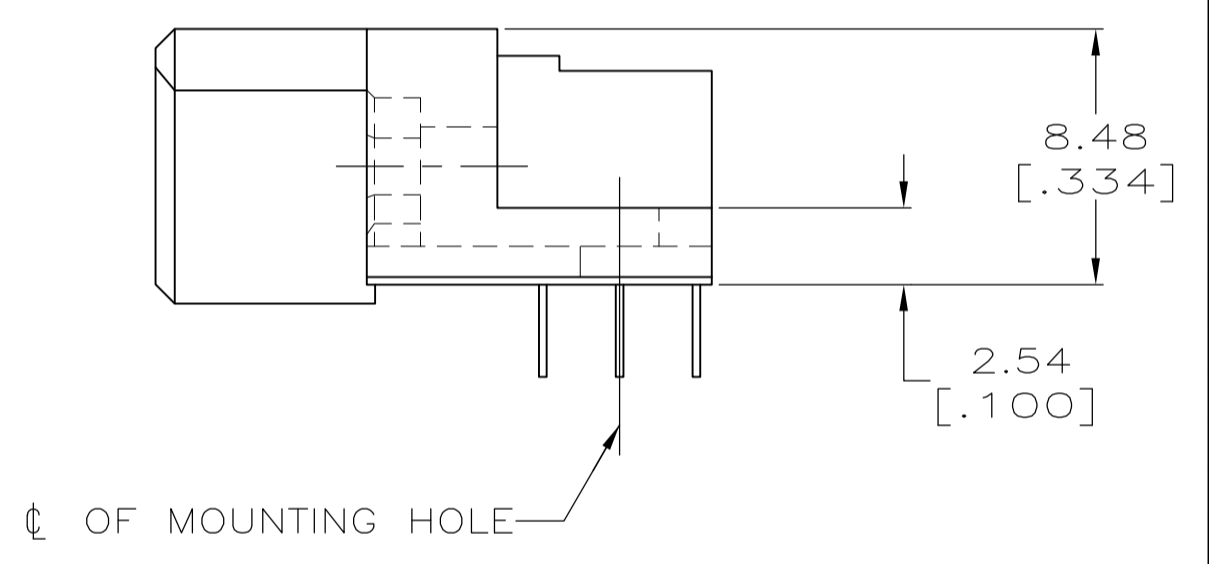
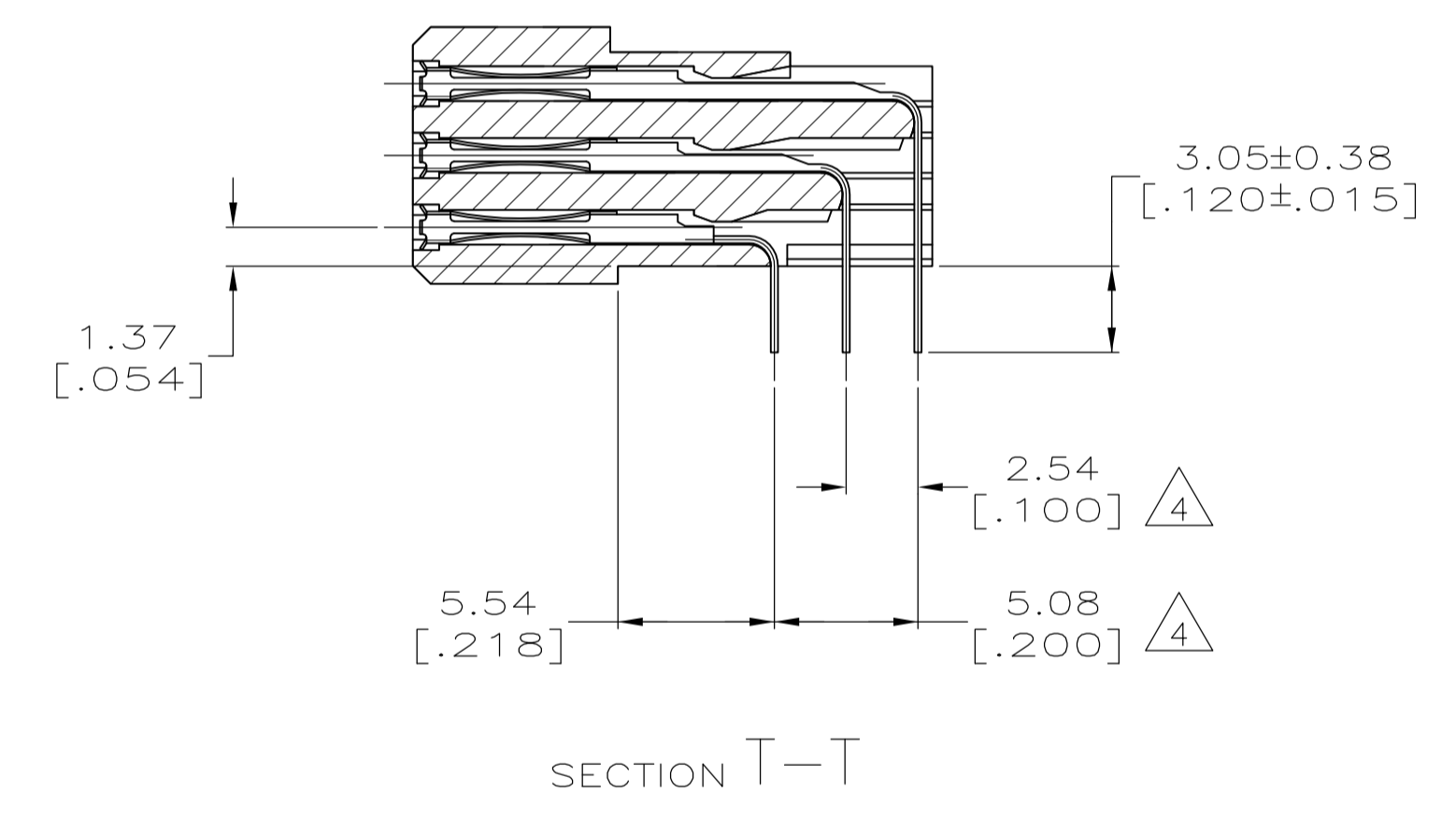
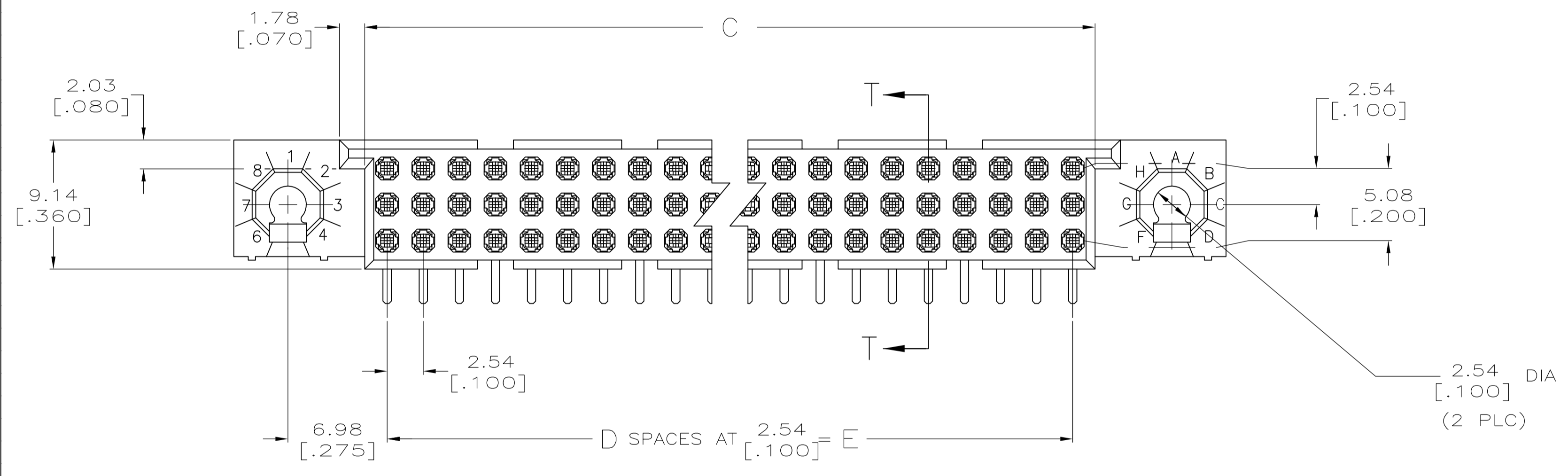
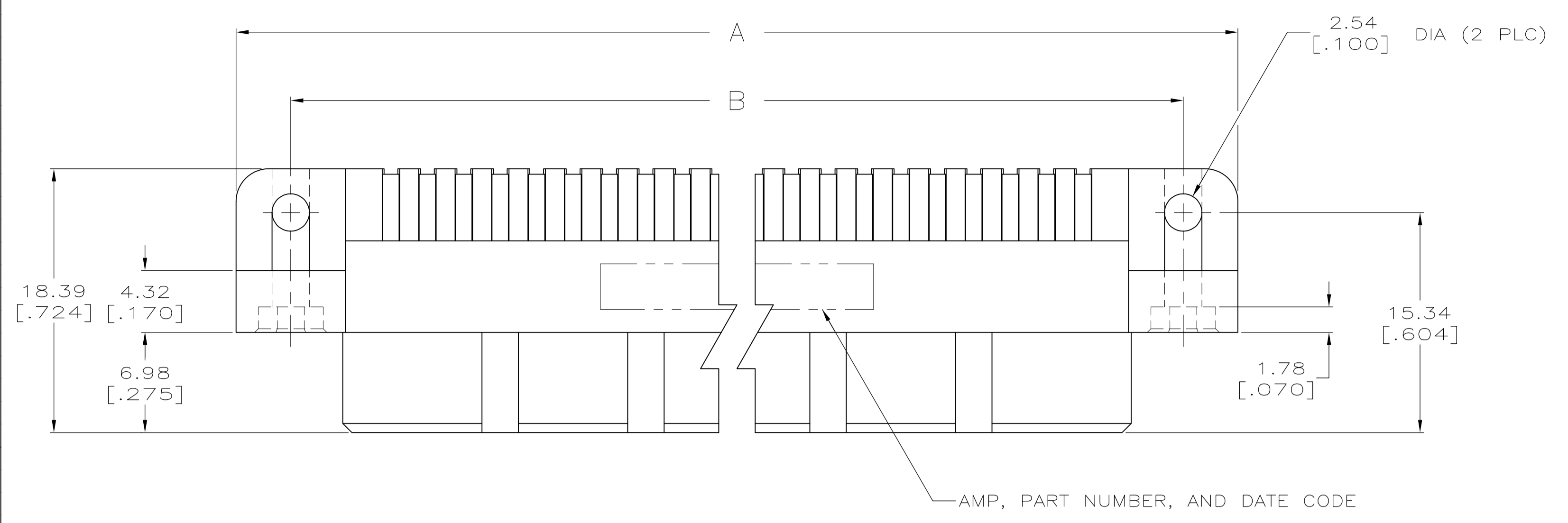

THIS DRAWING IS A CONTROLLED DOCUMENT.		DIN R.K. SEIFRIED 06/18/90	TE Connectivity																
DIMENSIONS: mm [INCHES]		CHK G. SKIPPER 10/6/92																	
TOLERANCES UNLESS OTHERWISE SPECIFIED:		APPD G. SKIPPER 10/6/92	NAME HDI, 3 ROW, RECEPTACLE ASSEMBLY, 3.05 [.120] LONG SOLDER TAILS																
<table border="1"> <tr><td>0 PLC</td><td>±</td><td>-</td></tr> <tr><td>1 PLC</td><td>±</td><td>-</td></tr> <tr><td>2 PLC</td><td>±</td><td>-</td></tr> <tr><td>3 PLC</td><td>±</td><td>0.13 [.005]</td></tr> <tr><td>4 PLC</td><td>±</td><td>-</td></tr> </table>		0 PLC	±	-	1 PLC	±	-	2 PLC	±	-	3 PLC	±	0.13 [.005]	4 PLC	±	-	APPLICATION SPEC		RESTRICTED TO
0 PLC	±	-																	
1 PLC	±	-																	
2 PLC	±	-																	
3 PLC	±	0.13 [.005]																	
4 PLC	±	-																	
MATERIAL		WEIGHT	SIZE A1	CAGE CODE 00779															
FINISH		DRAWING NO. 533268		REV															
CUSTOMER DRAWING		SCALE 4:1		SHEET 1 OF 2															

REVISIONS				
P	LTR	DESCRIPTION	DATE	APPV
-		SEE SHEET 1	-	-

- 1 HOUSING MATERIAL: THERMOPLASTIC, COLOR=NATURAL.
- 2 CONTACT MATERIAL: COPPER ALLOY.
- 3 FINISH:  
MATING AREA: MEETS THE PERFORMANCE REQUIREMENTS OF PRODUCT SPECIFICATION 108-9063; BASED ON TELCORDIA DR-1217-CORE APPLICATIONS IN UNCONTROLLED ENVIRONMENTS.  
SOLDER TAILS AREA: TIN-LEAD PLATED.
- 4 SOLDER TAILS MUST FIT HOLE PATTERN AS SHOWN ON THE RECOMMENDED P.C. BOARD LAYOUT.
- 5 DIMENSIONS IN BRACKETS ARE IN INCHES.
- 6 HOUSINGS WITH CENTER MOUNTING IS RECOMMENDED FOR ASSEMBLIES HAVING 75 CONTACTS PER ROW OR MORE.
- 7 PART NUMBER IS OBSOLETE.
- 8 FINISH:  
CONTACT FINISH: .00127-.00254 [.000050-.000100] NICKEL UNDERPLATE ALL OVER; .000762 [.000030] GOLD PLATE IN CONTACT AREA, TIN-LEAD PLATED POSTS.

7	22.86 [.900]	-9	26.01 [1.024]	36.83 [1.450]	44.45 [1.750]	-30	2-533268-0
	81.28 [3.200]	32	84.43 [3.324]	95.25 [3.750]	102.87 [4.050]	99	1-533268-9
7	144.78 [5.700]	-57	147.93 [5.824]	158.75 [6.250]	166.37 [6.550]	+74	1-533268-8
6 7	251.46 [9.900]	-99	254.61 [10.024]	265.43 [10.450]	273.05 [10.750]	-300	1-533268-7
6 7	238.76 [9.400]	-94	241.91 [9.524]	252.73 [9.950]	260.35 [10.250]	-285	1-533268-6
6	226.06 [8.900]	89	229.21 [9.024]	240.03 [9.450]	247.65 [9.750]	270	1-533268-5
6 7	213.36 [8.400]	-84	216.51 [8.524]	227.33 [8.950]	234.95 [9.250]	-255	1-533268-4
6	200.66 [7.900]	79	203.81 [8.024]	214.63 [8.450]	222.25 [8.750]	240	1-533268-3
	187.96 [7.400]	74	191.11 [7.524]	201.93 [7.950]	209.55 [8.250]	225	1-533268-2
7	175.26 [6.900]	-69	178.41 [7.024]	189.23 [7.450]	196.85 [7.750]	-210	1-533268-1
7	162.56 [6.400]	-64	165.71 [6.524]	176.53 [6.950]	184.15 [7.250]	+95	1-533268-0
	149.86 [5.900]	59	153.01 [6.024]	163.83 [6.450]	171.45 [6.750]	180	533268-9
	137.16 [5.400]	54	140.31 [5.524]	151.13 [5.950]	158.75 [6.250]	165	533268-8
	124.46 [4.900]	49	127.61 [5.024]	138.43 [5.450]	146.05 [5.750]	150	533268-7
	111.76 [4.400]	44	114.91 [4.524]	125.73 [4.950]	133.35 [5.250]	135	533268-6
	99.06 [3.900]	39	102.21 [4.024]	113.03 [4.450]	120.65 [4.750]	120	533268-5
	86.36 [3.400]	34	89.51 [3.524]	100.33 [3.950]	107.95 [4.250]	105	533268-4
	78.74 [3.100]	31	81.89 [3.224]	92.71 [3.650]	100.33 [3.950]	96	533268-3
7	73.66 [2.900]	-29	76.81 [3.024]	87.63 [3.450]	95.25 [3.750]	-90	533268-2
8	60.96 [2.400]	24	64.11 [2.524]	74.93 [2.950]	82.55 [3.250]	75	533268-1
	E	D	C	B	A	POSN	PART NUMBER

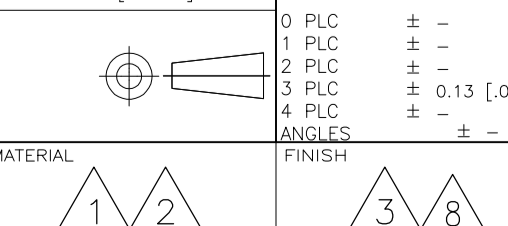
THIS DRAWING IS A CONTROLLED DOCUMENT.		DIN R. K. SEIFRIED CHK G. SKIPPER APPROV G. SKIPPER	06/18/90 10/6/92 10/6/92	 TE Connectivity	
DIMENSIONS: mm [INCHES]	TOLERANCES UNLESS OTHERWISE SPECIFIED:	NAME		HDI, 3 ROW, RECEPTACLE ASSEMBLY, 3.05 [1.20] LONG SOLDER TAILS	
0 PLC ± -	1 PLC ± -	PRODUCT SPEC		SIZE	
2 PLC ± -	3 PLC ± 0.13 [0.005]	APPLICATION SPEC		CAGE CODE	
4 PLC ± -	ANGLES ± -	WEIGHT		DRAWING NO	
MATERIAL	FINISH	CUSTOMER DRAWING		A1 00779 533268	
		SCALE 4:1		SHEET 2 OF 2	