

CE

YEAR
2000
COMPLIANT



User's Guide

omega.com[®]

Ω OMEGA[®]

<http://www.omega.com>
e-mail: info@omega.com

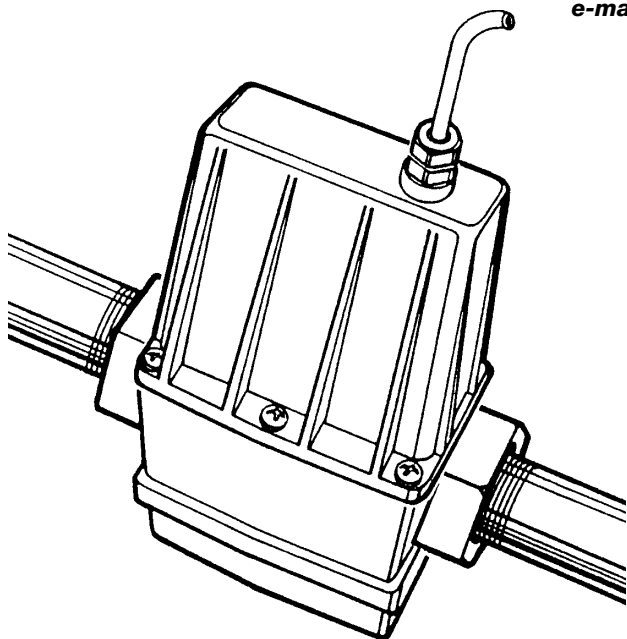

FLSC790-MA 4-20 mA Module



| | |
|--|---|
| OMEGAnet® On-Line Service http://www.omega.com | Internet e-mail info@omega.com |
|--|---|

Servicing North America:

USA:
ISO 9001 Certified

One Omega Drive, Box 4047
Stamford, CT 06907-0047
Tel: (203) 359-1660
e-mail: info@omega.com
FAX: (203) 359-7700

Canada:

976 Bergar
Laval (Quebec) H7L 5A1
Tel: (514) 856-6928
e-mail: info@omega.ca
FAX: (514) 856-6886

For immediate technical or application assistance:

USA and Canada:

Sales Service: 1-800-826-6342 / 1-800-TC-OMEGASM
Customer Service: 1-800-622-2378 / 1-800-622-BESTSM
Engineering Service: 1-800-872-9436 / 1-800-USA-WHENSM
TELEX: 996404 EASYLINK: 62968934 CABLE: OMEGA

Mexico and Latin America:

Tel: (001) 800-826-6342
En Español: (001) 203-359-7803
FAX: (001) 203-359-7807
e-mail: espanol@omega.com

Servicing Europe:

Benelux:

Postbus 8034, 1180 LA Amstelveen, The Netherlands
Tel: (31) 20 6418405
Toll Free in Benelux: 0800 0993344
e-mail: nl@omega.com
FAX: (31) 20 6434643

Czech Republic:

ul. Rude armady 1868, 733 01 Karvina-Hranice
Tel: 420 (69) 6311899
Toll Free: 0800-1-66342
e-mail: czech@omega.com
FAX: 420 (69) 6311114

France:

9, rue Denis Papin, 78190 Trappes
Tel: (33) 130-621-400
Toll Free in France: 0800-4-06342
e-mail: france@omega.com
FAX: (33) 130-699-120

Germany/Austria:

Daimlerstrasse 26, D-75392 Deckenpfronn, Germany
Tel: 49 (07056) 3017
Toll Free in Germany: 0130 11 21 66
e-mail: info@omega.de
FAX: 49 (07056) 8540

United Kingdom:

ISO 9002 Certified

One Omega Drive, River Bend Technology Centre
Northbank, Irlam, Manchester
M44 5EX, United Kingdom
Tel: 44 (0161) 777-6611
Toll Free in United Kingdom: 0800-488-488
e-mail: info@omega.co.uk
FAX: 44 (0161) 777-6622

It is the policy of OMEGA to comply with all worldwide safety and EMC/EMI regulations that apply. OMEGA is constantly pursuing certification of its products to the European New Approach Directives. OMEGA will add the CE mark to every appropriate device upon certification.

The information contained in this document is believed to be correct, but OMEGA Engineering, Inc. accepts no liability for any errors it contains, and reserves the right to alter specifications without notice.

WARNING: These products are not designed for use in, and should not be used for, patient-connected applications.

TABLE OF CONTENTS

| | |
|---------------------------------|---|
| Introduction | 1 |
| Installation | 1 |
| Wiring | 2 |
| Calibration | 4 |
| Dimensions | 5 |
| Specifications | 6 |
| Parts List | 7 |
| Troubleshooting | 7 |
| Warranty/Disclaimer | 9 |
| Return Requests/Inquiries | 9 |

INTRODUCTION

Caution: This 4-20 mA Module is not FM Approved. Therefore, use of this module with an approved metering system, voids FM Approval.

NOTE: This module requires an input power supply of 7 to 30 volts DC. (24 VDC is recommended) The DC signal will power the meter electronics, leaving the batteries as backup for the meter electronics.

NOTE: Field Calibration is required.

This manual is designed to be used only with FTB790 Series Turbine Meters. More specifically, turbine housings with the following models: FTB791, FTB792, FTB793, FTB794, and FTB795.

INSTALLATION

To install this module, follow the instructions given below.

1. Remove the back coverplate from the turbine housing.
2. Remove the display electronics from the front of the turbine.

NOTE: If you are installing more than one module at a time, take care to keep the proper electronics paired with the original turbine.

3. The 4-20 mA Module connects to a 10-pin connector located on the back side of the computer electronics next to the negative battery connectors. The 10-pin connector is sealed with a clear plastic

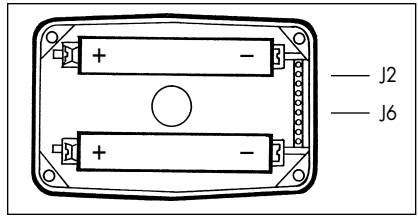

sealant that must be carefully pried out with a small sharp tool inserted gently at the edges.

4. Remove the backing from the double-sided tape on the module's circuit assembly.
5. Carefully align the top pin on the circuit assembly with the J2 position on the 10-pin connector and gently press the module's circuit assembly into position between the batteries. The bottom pin will align with the J6 position.
6. Guide the loose ends of the wires from the circuit assembly through the housing's cavity to the back side of the turbine.
7. Install the display electronics to the front side of the turbine and tighten the four screws snugly.
8. Connect the loose ends of the wires from the electronics circuit assembly to the terminal block marked "From EDM." Connect wires per colors noted beside connection pins.

NOTE: Ten feet of wire is provided with the module. If trimming is necessary, do it now. If you provide your own wire, prepare it for connection prior to the next step.

9. Connect the wires at the module's terminal block marked "Cable from Customer" as illustrated in Wiring Section.
10. Complete connections to the interface device according to the manufacturer's instructions.
11. Before installing the module onto the turbine housing, adjust the ZERO and SPAN trim pots as noted in Calibration Section. When adjustments are finished, make sure the O-ring is fully seated and no wires are pinched. Then, secure the module onto the housing by snugly tightening the six screws provided with the module.

WIRING

This is the wiring diagram for the 4-20 mA output.

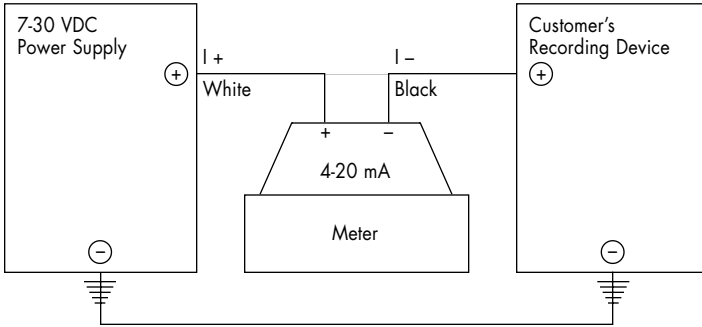

Output (4-20 mA)

4-20 mA Module Terminal Connections

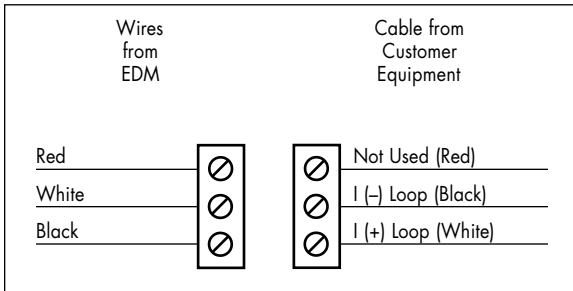

Wires from EDM detail:

White wire from 10-pin connector J2.

Red wire from 10-pin connector J5.

Black wire from 10-pin connector J6.

WIRING

This is the wiring diagram for the 0-5 V output.

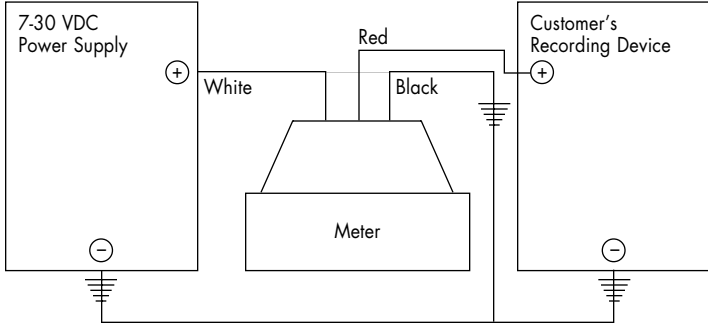

Secondary Output (0-5 Volt) (1-4 VDC)

0-5 Volt Terminal Connections

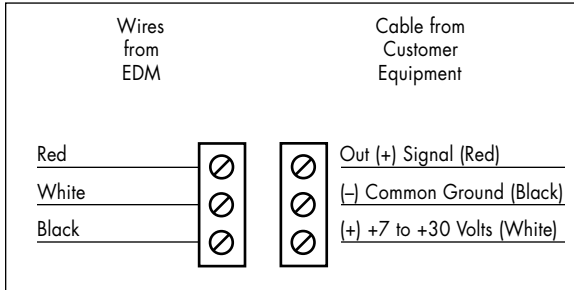

Wires from EDM detail:

White wire from 10-pin connector J2.

Red wire from 10-pin connector J5.

Black wire from 10-pin connector J6.

CALIBRATION

Adjusting ZERO and SPAN

The following adjustments apply to both the 4-20 mA and 0-5 V outputs. The factory recommends when using 0-5 V signal, do not go below 1 V or above 4 V as output signal in the linear range.

Before initial adjustments, set both trimpots to their maximum position by turning each control clockwise twenty (20) turns. The control's internal clutch will click quietly at the end position.

To adjust Zero reading, start fluid flow at its lowest anticipated flowrate within the linear flow range of the turbine. Then turn the ZERO trimpot counterclockwise until the indicated reading begins to rise from 4 mA (or 1 V). Then turn back to the 4 mA (or 1 V)

reading. This is the true ZERO read. Any flowrate below this "threshold," including no flow, will produce a 4 mA (or 1 V) reading.

To adjust SPAN, start the fluid flow to its highest anticipated flowrate within the linear flow range of the turbine. Then, turn the SPAN trimpot counterclockwise until the indicator just drops to 20 mA (or 4 V). Any flowrate above this will produce an indication higher than 20 mA (or 4 V).

Usually, no further adjustment will be required. However, if "fine tuning" is required, note that adjustments in ZERO trimpot will require adjustments in SPAN. the converse is not true, adjusting the SPAN setting will have little or no effect on the ZERO setting.

DIMENSIONS

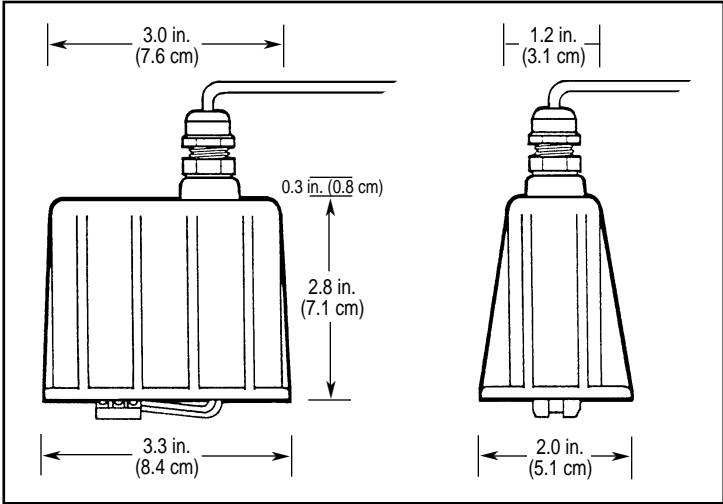

SPECIFICATIONS

Mechanical

| | |
|------------------------|---|
| Housing Material: | Nylon 6/6 |
| Strain Relief: | Hubble PG7. Grip range 0.11-0.26 |
| Strain Relief Thread: | Female 1/2-20 UNF-2B |
| Cable: | Belden 9363 (22AWG-2 conductor w/drain wire and shield) |
| Cable Length: | 10 ft. (3m) provided |
| Operation Temperature: | 0° to +150°F (-17° to 65°C) |
| Storage Temperature: | -40° to +180°F (-40° to +82°C) |

Power

| | |
|-------------------|--------------|
| Type: | Loop powered |
| Burden (Minimum): | 7 VDC |
| Maximum: | 30 VDC |
| Isolated: | No |

Primary Output (4-20 mA)

| | |
|----------|-------|
| Type: | Loop |
| Minimum: | 4 mA |
| Maximum: | 25 mA |

Output (0-5 Volt)

| | |
|----------|--------------|
| Type: | Voltage Mode |
| Minimum: | 1 Volt |
| Maximum: | 4 Volts |

Input

Open Collector from FTB790 Series Electronics or Conditioned Signal Module.
4-20 mA Module will accept frequencies generated only by FTB790 Series turbine housings. This module should not be used with frequency generating devices other than FTB790 Series Models.

PARTS LIST

| Part Number | Description | Qty. |
|-------------|---|------|
| 901002-52 | O-ring | 1 |
| 125501-1 | Circuit Assembly Kit (10 pin connector) | 1 |
| 904005-27 | Screws | 6 |

Call OMEGA Sales Department and reference base part number (FLSC790-MA) to order spare parts.

TROUBLESHOOTING

| Symptom | Probable Cause | Corrective Action |
|-----------------------------|-----------------------------------|---|
| No output signal | 1. Incorrect or no input power | Supply correct power requirements. |
| | 2. Not wired correctly | Check owner's manual for correct installation. |
| | 3. Broken connection | Check resistance to determine location of break. |
| | 4. Defective PC board connector | Contact distributor or factory for replacement. |
| | 5. Defective unit | Contact distributor or factory for replacement. |
| Signal does rise above 4 mA | 1. Zero trimpot not set correctly | Reinitiate Zero & Span adjustments - careful to increase Zero read above 4 and then turn back to 4 mA reading to avoid false 4 mA signal. |
| | 2. No signal from meter | See Turbine and Display Electronics owner's manual. |

NOTES



WARRANTY / DISCLAIMER

OMEGA ENGINEERING, INC. warrants this unit to be free of defects in materials and workmanship for a period of **13 months** from date of purchase. OMEGA Warranty adds an additional one (1) month grace period to the normal **one (1) year product warranty** to cover handling and shipping time. This ensures that OMEGA's customers receive maximum coverage on each product.

If the unit malfunctions, it must be returned to the factory for evaluation. OMEGA's Customer Service Department will issue an Authorized Return (AR) number immediately upon phone or written request. Upon examination by OMEGA, if the unit is found to be defective, it will be repaired or replaced at no charge. OMEGA's WARRANTY does not apply to defects resulting from any action of the purchaser, including but not limited to mishandling, improper interfacing, operation outside of design limits, improper repair, or unauthorized modification. This WARRANTY is VOID if the unit shows evidence of having been tampered with or shows evidence of having been damaged as a result of excessive corrosion; or current, heat, moisture or vibration; improper specification; misapplication; misuse or other operating conditions outside of OMEGA's control. Components which wear are not warranted, including but not limited to contact points, fuses, and triacs.

OMEGA is pleased to offer suggestions on the use of its various products. However, OMEGA neither assumes responsibility for any omissions or errors nor assumes liability for any damages that result from the use of its products in accordance with information provided by OMEGA, either verbal or written. OMEGA warrants only that the parts manufactured by it will be as specified and free of defects. OMEGA MAKES NO OTHER WARRANTIES OR REPRESENTATIONS OF ANY KIND WHATSOEVER, EXPRESS OR IMPLIED, EXCEPT THAT OF TITLE, AND ALL IMPLIED WARRANTIES INCLUDING ANY WARRANTY OF MERCHANTABILITY AND FITNESS FOR A PARTICULAR PURPOSE ARE HEREBY DISCLAIMED. LIMITATION OF LIABILITY: The remedies of purchaser set forth herein are exclusive, and the total liability of OMEGA with respect to this order, whether based on contract, warranty, negligence, indemnification, strict liability or otherwise, shall not exceed the purchase price of the component upon which liability is based. In no event shall OMEGA be liable for consequential, incidental or special damages.

CONDITIONS: Equipment sold by OMEGA is not intended to be used, nor shall it be used: (1) as a "Basic Component" under 10 CFR 21 (NRC), used in or with any nuclear installation or activity; or (2) in medical applications or used on humans. Should any Product(s) be used in or with any nuclear installation or activity, medical application, used on humans, or misused in any way, OMEGA assumes no responsibility as set forth in our basic WARRANTY/DISCLAIMER language, and, additionally, purchaser will indemnify OMEGA and hold OMEGA harmless from any liability or damage whatsoever arising out of the use of the Product(s) in such a manner.

RETURN REQUESTS / INQUIRIES

Direct all warranty and repair requests/inquiries to the OMEGA Customer Service Department. BEFORE RETURNING ANY PRODUCT(S) TO OMEGA, PURCHASER MUST OBTAIN AN AUTHORIZED RETURN (AR) NUMBER FROM OMEGA'S CUSTOMER SERVICE DEPARTMENT (IN ORDER TO AVOID PROCESSING DELAYS). The assigned AR number should then be marked on the outside of the return package and on any correspondence. The purchaser is responsible for shipping charges, freight, insurance and proper packaging to prevent breakage in transit.

FOR **WARRANTY** RETURNS, please have the following information available BEFORE contacting OMEGA:

1. Purchase Order number under which the product was PURCHASED,
2. Model and serial number of the product under warranty, and
3. Repair instructions and/or specific problems relative to the product.

FOR **NON-WARRANTY** RETURNS, consult OMEGA for current repair charges. Have the following information available BEFORE contacting OMEGA:

1. Purchase Order number to cover the COST of the repair,
2. Model and serial number of the product, and
3. Repair instructions and/or specific problems relative to the product.

OMEGA's policy is to make running changes, not model changes, whenever an improvement is possible. This affords our customers the latest in technology and engineering.

OMEGA is a registered trademark of OMEGA ENGINEERING, INC.

© Copyright 1998 OMEGA ENGINEERING, INC. All rights reserved. This document may not be copied, photocopied, reproduced, translated, or reduced to any electronic medium or machine-readable form, in whole or in part, without the prior written consent of OMEGA ENGINEERING, INC.

Where Do I Find Everything I Need for Process Measurement and Control? OMEGA... Of Course!

TEMPERATURE

- Thermocouple, RTD & Thermistor Probes, Connectors, Panels & Assemblies
- Wire: Thermocouple, RTD & Thermistor
- Calibrators & Ice Point References
- Recorders, Controllers & Process Monitors
- Infrared Pyrometers

PRESSURE, STRAIN AND FORCE

- Transducers & Strain Gauges
- Load Cells & Pressure Gauges
- Displacement Transducers
- Instrumentation & Accessories

FLOW/LEVEL

- Rotameters, Gas Mass Flowmeters & Flow Computers
- Air Velocity Indicators
- Turbine/Paddlewheel Systems
- Totalizers & Batch Controllers

pH/CONDUCTIVITY

- pH Electrodes, Testers & Accessories
- Benchtop/Laboratory Meters
- Controllers, Calibrators, Simulators & Pumps
- Industrial pH & Conductivity Equipment

DATA ACQUISITION

- Data Acquisition & Engineering Software
- Communications-Based Acquisition Systems
- Plug-in Cards for Apple, IBM & Compatibles
- Datalogging Systems
- Recorders, Printers & Plotters

HEATERS

- Heating Cable
- Cartridge & Strip Heaters
- Immersion & Band Heaters
- Flexible Heaters
- Laboratory Heaters

ENVIRONMENTAL MONITORING AND CONTROL

- Metering & Control Instrumentation
- Refractometers
- Pumps & Tubing
- Air, Soil & Water Monitors
- Industrial Water & Wastewater Treatment
- pH, Conductivity & Dissolved Oxygen Instruments