

RM Core Components

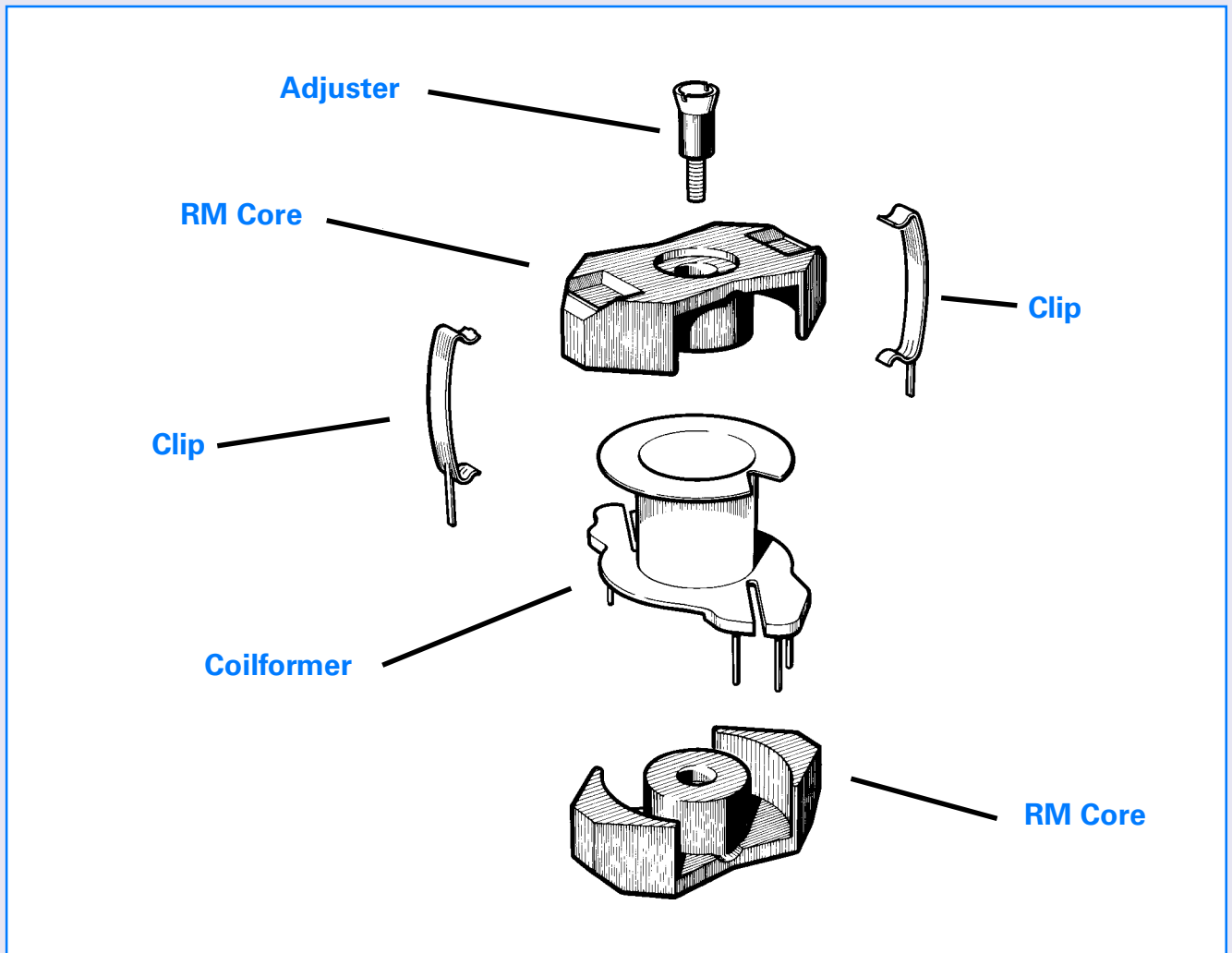

RM Cores

RM (Rectangular modulus) cores arose due to the demand for coil formers with integrated pins that allow for efficient winding and high PCB packing densities. Clamps engaging in recesses in the core base hold the cores in place, meaning glue is not normally required in this process.

All the cores adhere to specifications laid down in IEC 431 and in DIN 41980. The coil formers adhere to DIN 41981.

RM cores are designed for two main applications:

- Highly stable, extremely low loss filter inductors and other resonance determining inductors (F58, P11).
- Low distortion broadband transmission at low signal modulation (F39, F10, F9).

RM cores can also be supplied without the centre hole. These have a higher A_L value and cross sectional area and are used for power transformer applications (F47, F44, F45, F5A).

RM 4 29-900-

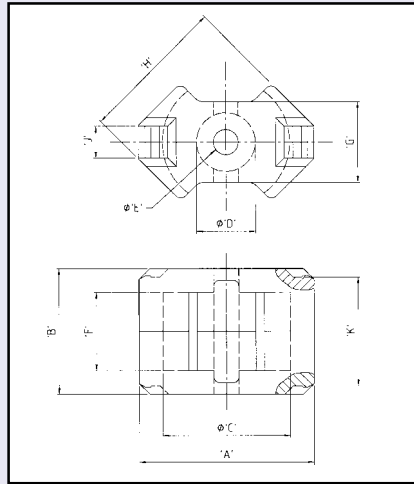
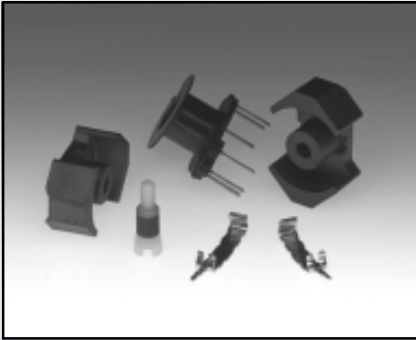

Core Dimensions (mm)

A	10.60 - 11.00	F	7.00 - 7.40
B	10.30 - 10.50	G	4.40 - 4.60
C	7.95 - 8.35	H	9.50 - 9.80
D	3.70 - 3.90	J	2.50 - 2.70
E	2.00 - 2.10	K	8.76 - 9.26

Core Parameters

In accordance with IEC Document 60205.

Parameter	Σ/A	Effective Length	Effective Area	Minimum Area	Effective Volume
Symbol	C_1	l_e	A_e	A_{min}	V_e
Value	1.90mm ⁻¹	21.0mm	11.0mm ²	-	232.0mm ³

Electrical Specification

Material	A_L Value	Tolerance	Gap Length	Eff. Permeability	Part Number
F9	1700	+30/-20%	-	2570	29-900-36
F44	800	+30/-20%	-	1210	29-900-44
P11	900	+30/-20%	-	1360	29-900-41
P11	63	±3%	0.18	95	29-901-41*
P11	100	±3%	0.12	150	29-902-41*
P11	160	±3%	0.06	240	29-903-41*
P11	250	±3%	0.03	375	29-904-41*
P11	100	±3%	0.12	150	29-912-41**
P11	160	±3%	0.06	240	29-913-41**
P11	250	±3%	0.03	375	29-914-41**

*Part number refers to a pair of cores fitted with a nut for adjustable inductance assemblies.

**Part number denotes a gapped pair without nut. Other part numbers refer to half cores.

Bobbins/Coil Formers

Mounting	No. of Sections	Pins	Part Number
Vertical (AS)	1	4	60-901S64
Vertical (AS)	1	6	60-903S64

Other pin lengths or variation may be listed at the end of this section

Adjusters

A_L Value	Part Number
63/100	64-020-66
160/250	64-021-66
Clip	76-024-95



Core Dimensions (mm)

A	10.60 - 11.00	F	7.00 - 7.40
B	10.30 - 10.50	G	4.40 - 4.60
C	7.95 - 8.35	H	9.50 - 9.80
D	3.70 - 3.90	J	2.50 - 2.70
E	—	K	8.76 - 9.26

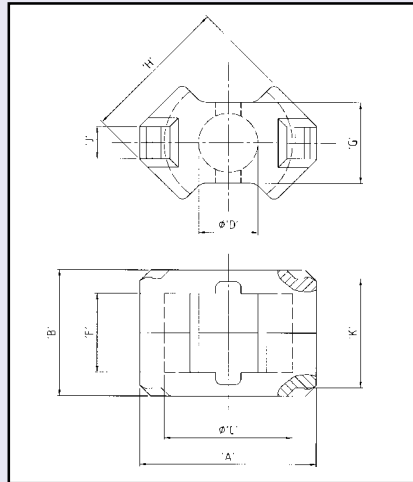

RM 4 SOLID 29-920-

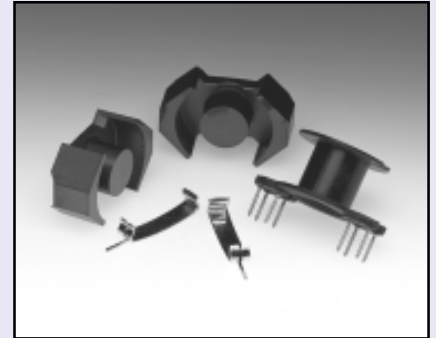

Core Parameters

In accordance with IEC Document 60205.

Parameter	$\Sigma l/A$	Effective Length	Effective Area	Minimum Area	Effective Volume
Symbol	C_1	l_e	A_e	A_{min}	V_e
Value	1.70mm ⁻¹	22.0mm	13.0mm ²	11.3mm ²	286.0mm ³

Electrical Specification

Material	A_L Value	Tolerance	Gap Length	Eff. Permeability	Part Number
F9	1900	+30/-20%	-	2570	29-920-36
F10	2800	+30/-20%	-	3790	29-920-37
F39	3700	+40/-30%	-	5000	29-920-39
F44	860	+30/-20%	-	1160	29-920-44
F44	100	±5%	0.35	75	29-921-44*
F44	160	±5%	0.20	120	29-922-44*
F44	250	±5%	0.10	188	29-923-44*

Part numbers refer to half cores.

*Part number refers to a pair of cores.

Bobbins/Coil Formers

Mounting	No. of Sections	Pins	Part Number
Vertical (AS)	1	4	60-901S64
Vertical (AS)	1	6	60-902S64

Clip

Part Number
76-024-95

Other pin lengths and versions may be listed at the end of this section

RM 5- 29-700-

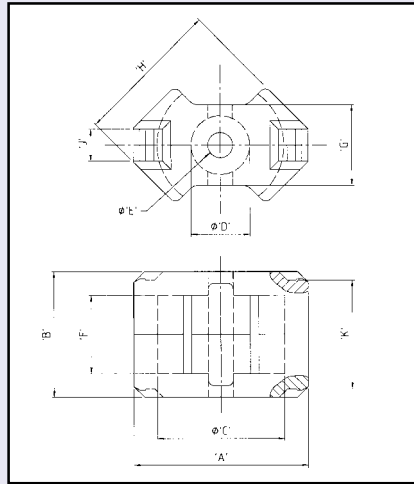
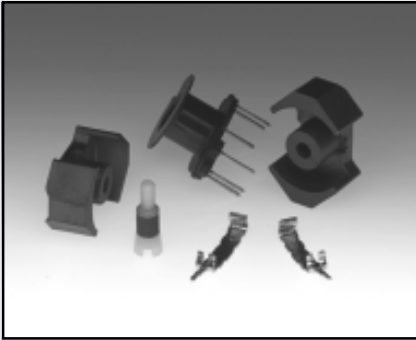

Core Dimensions (mm)

A	14.00 - 14.60	F	6.30 - 6.70
B	10.30 - 10.50	G	6.40 - 6.80
C	10.20 - 10.60	H	11.80 - 12.30
D	4.70 - 4.90	J	2.50 - 2.70
E	2.00 - 2.10	K	8.76 - 9.26

Core Parameters

In accordance with IEC Document 60205.

Parameter	Σ/A	Effective Length	Effective Area	Minimum Area	Effective Volume
Symbol	C_1	l_e	A_e	A_{min}	V_e
Value	1.00mm ⁻¹	20.80mm	20.80mm ²	15.0mm ²	430.0mm ³

Electrical Specification

Material	A_L Value	Tolerance	Gap Length	Eff. Permeability	Part Number
F10	4800	+30/-20%	-	3820	29-700-37
F39	6000	+40/-30%	-	4775	29-700-39
P11	1840	+30/-20%	-	1460	29-700-41
P11	100	±3%	0.18	80	29-701-41*
P11	160	±3%	0.12	128	29-702-41*
P11	250	±3%	0.06	200	29-703-41*
P11	315	±3%	0.03	250	29-704-41*
P11	100	±5%	0.18	80	29-711-41**
P11	160	±5%	0.12	128	29-712-41**
P11	250	±5%	0.06	200	29-713-41**

*Part number refers to a pair of cores fitted with a nut for adjustable inductance assemblies.

**Part number denotes a pair of cores without nut. Other part numbers refer to half cores.

Bobbins/Coil Formers

Mounting	No. of Sections	Pins	Part Number
Vertical (AS)	1	4	60-701S64
Vertical (AS)	1	6	60-702S64

Other pin lengths or variation may be listed at the end of this section

Adjusters

A_L Value	Part Number
100/160	64-020-66
250/315	64-021-66
Clip	76-024-95



Core Dimensions (mm)

A	14.00 - 14.60	F	6.30 - 6.70
B	10.30 - 10.50	G	6.40 - 6.80
C	10.20 - 10.60	H	11.80 - 12.30
D	4.70 - 4.90	J	2.50 - 2.70
E	—	K	8.76 - 9.26

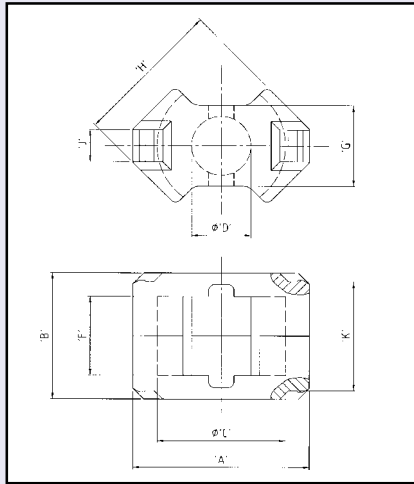

RM 5 SOLID 29-720-

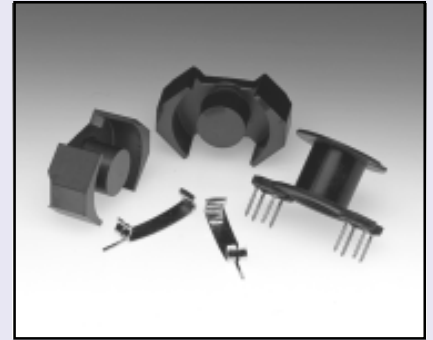

Core Parameters

In accordance with IEC Document 60205.

Parameter	$\Sigma I/A$	Effective Length	Effective Area	Minimum Area	Effective Volume
Symbol	C_1	l_e	A_e	A_{min}	V_e
Value	0.93mm ⁻¹	22.10mm	23.80mm ²	18.0mm ²	526.0mm ³

Electrical Specification

Material	A_L Value	Tolerance	Gap Length	Eff. Permeability	Part Number
F9	3840	+30/-20%	-	2840	29-720-36
F10	4815	+30/-20%	-	3563	29-720-37
F39	6700	+40/-30%	-	4960	29-720-39
F47	1520	+30/-20%	-	1125	29-720-47
F44	1570	+30/-20%	-	1160	29-720-44
F44	100	±5%	0.35	74	29-721-44*
F44	160	±5%	0.20	118	29-722-44*
F44	250	±5%	0.12	185	29-723-44*

Part numbers refer to half cores.

*Part number refers to a pair of cores.

Bobbins/Coil Formers

Mounting	No. of Sections	Pins	Part Number
Vertical (AS)	1	4	60-701S64
Vertical (AS)	1	6	60-702S64

Clip

Part Number
76-024-95

Other pin lengths and versions may be listed at the end of this section

RM 6

29-730-

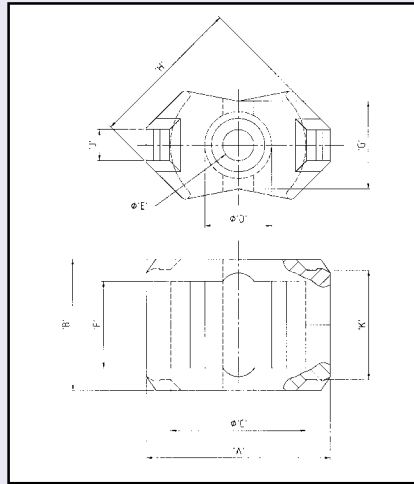
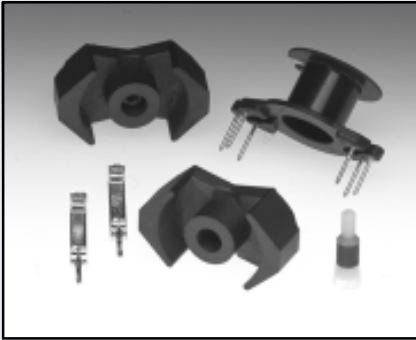

Core Dimensions (mm)

A	17.30 - 17.90	F	8.00 - 8.40
B	12.30 - 12.50	G	7.80 - 8.20
C	12.40 - 12.90	H	14.10 - 14.70
D	6.10 - 6.40	J	2.80 - 2.90
E	2.80 - 3.00	K	10.10 - 10.58

Core Parameters

In accordance with IEC Document 60205.

Parameter	Σ/A	Effective Length	Effective Area	Minimum Area	Effective Volume
Symbol	C_1	l_e	A_e	A_{min}	V_e
Value	0.87mm ⁻¹	27.0mm	31.0mm ²	-	840.0mm ³

Electrical Specification

Material	A_L Value	Tolerance	Gap Length	Eff. Permeability	Part Number
F58	890	+30/-20%	-	615	29-730-58
P11	2000	+30/-20%	-	1385	29-730-41
F58	40	±3%	-	28	29-7302-58*
F58	63	±3%	0.60	44	29-7303-58*
F58	100	±3%	0.38	70	29-7304-58*
P11	100	±3%	0.50	70	29-7304-41*
P11	160	±3%	0.20	110	29-7305-41*
P11	250	±3%	0.11	175	29-7306-41*
P11	400	±3%	0.05	275	29-7308-41*
P11	630	±10%	0.03	436	29-7309-41*

*Part number refers to a pair of cores fitted with a nut for adjustable inductance assemblies. Non adjustable cores may also be available on request. Part numbers refer to half cores.

Bobbins/Coil Formers

Mounting	No. of Sections	Pins	Part Number
Vertical (AS)	1	4	60-731-64
Vertical (AS)	1	6	60-7303-64

Other pin lengths or variation may be listed at the end of this section

Adjusters

A_L Value	Part Number
65/100/160	64-025-66
250	64-026-66
400/630	64-027-66
Clip	76-020-95



Core Dimensions (mm)

A	17.30-17.90	F	8.00-8.40
B	12.30-12.50	G	7.80-8.20
C	12.40-12.90	H	14.10-14.70
D	6.10-6.40	J	2.80-2.90
E	—	K	10.10-10.58

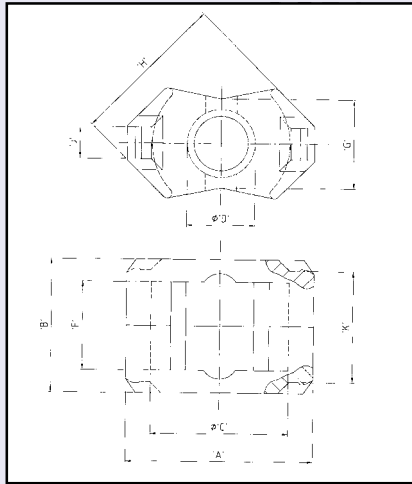

RM 6 SOLID 29-750-

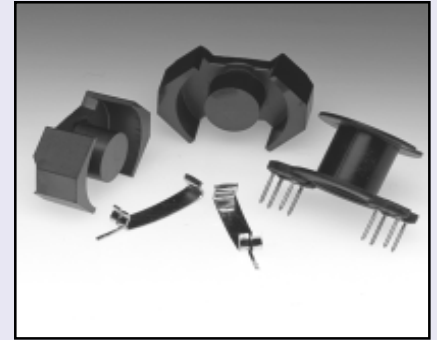

Core Parameters

In accordance with IEC Document 60205.

Parameter	Σ/A	Effective Length	Effective Area	Minimum Area	Effective Volume
Symbol	C_1	l_e	A_e	A_{min}	V_e
Value	0.78mm ⁻¹	29.0mm	37.0mm ²	31.0mm ²	1090.0mm ³

Electrical Specification

Material	A_L Value	Tolerance	Gap Length	Eff. Permeability	Part Number
F9	4300	+30/-20%	-	2670	29-750-36
F10	6200	+30/-20%	-	3850	29-750-37
F39	8600	+40/-30%	-	5330	29-750-39
F47	2050	+30/-20%	-	1270	29-750-47
F45	2400	+30/-20%	-	1490	29-750-45
F44	2000	+30/-20%	-	1370	29-750-44
F44	100	±5%	0.50	62	29-751-44*
F44	160	±5%	0.20	100	29-752-44*
F44	250	±5%	0.11	155	29-753-44*
F44	400	±5%	0.05	248	29-755-44*

Part numbers refer to half cores.

*Part number refers to a pair of cores.

Bobbins/Coil Formers

Mounting	No. of Sections	Pins	Part Number
Vertical (AS)	1	4	60-731-64
Vertical (AS)	1	6	60-7303-64

Clip

Part Number
76-020-95

Other pin lengths and versions may be listed at the end of this section

RM 7

29-7600-

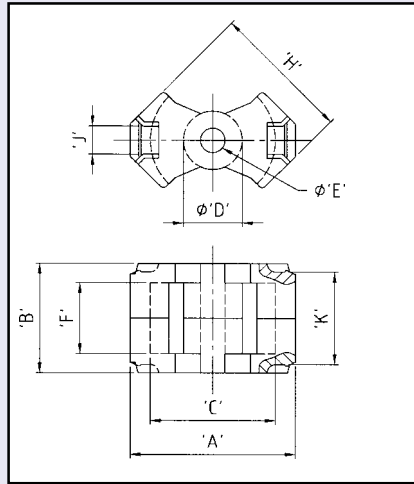

Core Dimensions (mm)

A	19.50-20.30	F	8.50-8.90
B	13.30-13.50	G	—
C	14.76-15.36	H	16.50-17.20
D	6.96-7.24	J	3.20-3.60
E	2.94-3.12	K	11.06-11.54

Core Parameters

In accordance with IEC Document 60205.

Parameter	Σ/A	Effective Length	Effective Area	Minimum Area	Effective Volume
Symbol	C_1	l_e	A_e	A_{min}	V_e
Value	0.74mm ⁻¹	29.80mm	40.00mm ²	-	1200.00mm ³

Electrical Specification

Material	A_L Value	Tolerance	Gap Length	Eff. Permeability	Part Number
F9	4690	+30/-20%	-		29-7600-36
P11	2860	+30/-20%	-		29-7600-41
P11	100	±3%	0.76		29-7604-41*
P11	160	±3%	0.40		29-7605-41*
P11	250	±3%	0.25		29-7606-41*
P11	400	±3%	0.15		29-7608-41*
P11	100	±5%	0.70		29-7704-41**
P11	160	±5%	0.40		29-7705-41**
P11	250	±5%	0.25		29-7706-41**
P11	400	±5%	0.15		29-7708-41**

Part numbers refer to half cores.

**Part number denotes solid core.

*Part number refers to a pair of cores fitted with a nut for adjustable inductance assemblies.

Bobbins/Coil Formers

Mounting	No. of Sections	Pins	Part Number
Vertical (AS)	1	4	60-7601-64
Vertical (AS)	1	6	60-7604-64

Other pin lengths or variation may be listed at the end of this section

Adjusters

A_L Value	Part Number
63/100/160	64-025-66
250	64-026-66
400/630	64-027-66
Clip	76-021-95



Core Dimensions (mm)

A	19.50-20.30	F	8.50-8.90
B	13.30-13.50	G	—
C	14.76-15.36	H	16.50-17.20
D	6.96-7.24	J	3.20-3.60
E	—	K	11.06-11.54

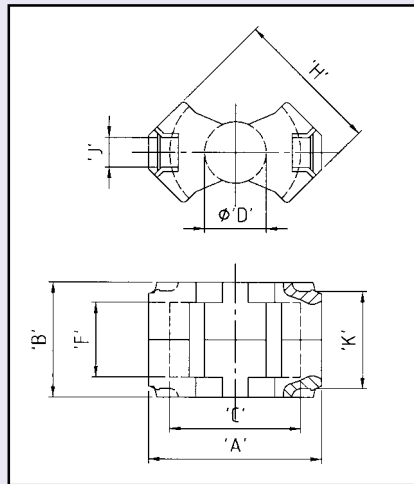

RM 7 SOLID 29-7800-

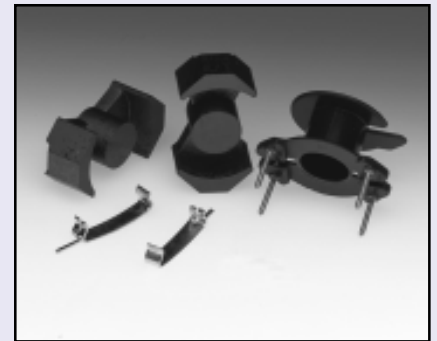

Core Parameters

In accordance with IEC Document 60205.

Parameter	Σ/A	Effective Length	Effective Area	Minimum Area	Effective Volume
Symbol	C_1	l_e	A_e	A_{min}	V_e
Value	0.70mm^{-1}	30.40mm	43.0mm^2	39.0mm^2	1340.0mm^3

Electrical Specification

Material	A_L Value	Tolerance	Gap Length	Eff. Permeability	Part Number
F9	5000	+30/-20%	-	3150	29-7800-36
F10	7000	+30/-20%	-	3900	29-7800-37
F39	10000	+40/-30%	-	5700	29-7800-39
F44	2370	+30/-20%	-	1320	29-7800-44
F5A	2850	+30/-20%	-	1590	29-7800-49
F44	100	$\pm 5\%$	0.70	55	29-7804-44*
F44	160	$\pm 5\%$	0.40	90	29-7805-44*
F44	250	$\pm 5\%$	0.25	140	29-7806-44*
F44	400	$\pm 5\%$	0.15	225	29-7808-44*

Part numbers refer to half cores.

*Part number refers to a pair of cores.

Bobbins/Coil Formers

Mounting	No. of Sections	Pins	Part Number
Vertical (AS)	1	4	60-7601-64
Vertical (AS)	1	8	60-7604-64

Clip

Part Number
76-021-95

Other pin lengths and versions may be listed at the end of this section

RM 8

29-790-

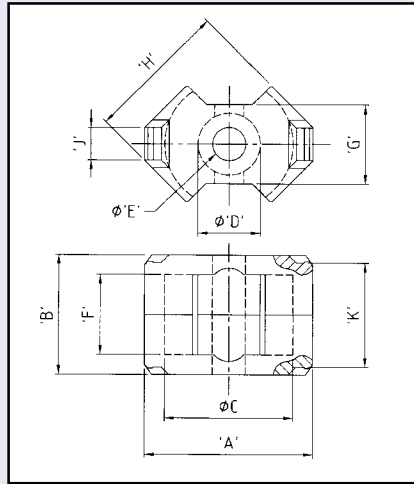
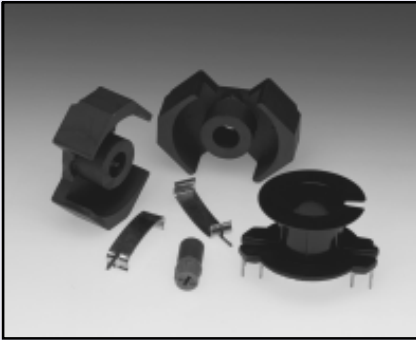

Core Dimensions (mm)

A	22.30 - 23.20	F	10.80 - 11.20
B	16.30 - 16.50	G	10.50 - 11.40
C	17.00 - 17.70	H	18.90 - 19.70
D	8.25 - 8.55	J	4.30 - 5.10
E	4.40 - 4.60	K	14.06 - 14.54

Core Parameters

In accordance with IEC Document 60205.

Parameter	Σ/A	Effective Length	Effective Area	Minimum Area	Effective Volume
Symbol	C_1	l_e	A_e	A_{min}	V_e
Value	0.68mm ⁻¹	35.50mm	52.00mm ²	-	1850.00mm ³

Electrical Specification

Material	A_L Value	Tolerance	Gap Length	Eff. Permeability	Part Number
P11	2500	+30/-20%	-	1350	29-790-41
F58	1170	+30/-20%	-	630	29-790-58
F58	63	±3%	1.40	34	29-7903-58*
F58	100	±3%	0.80	54	29-7904-58*
P11	100	±3%	0.86	54	29-7904-41*
P11	160	±3%	0.40	86	29-7905-41*
P11	250	±3%	0.23	135	29-7906-41*
P11	315	±3%	0.18	170	29-7907-41*
P11	400	±3%	0.13	216	29-7908-41*
P11	630	±3%	0.08	341	29-7909-41*

Part numbers refer to half cores.
Non adjustable type may be available on request.

*Part number refers to a pair of cores fitted with a nut for adjustable inductance assemblies.

Bobbins/Coil Formers

Mounting	No. of Sections	Pins	Part Number
Vertical (Z)	1	8	60-792-64
Vertical (AS)	1	12	60-793-64

Other pin lengths or variation may be listed at the end of this section

Adjusters

A_L Value	Part Number
63/100/160	64-4834-66
250/400	64-4833-66
630	64-4835-66
Clip	76-022-95



Core Dimensions (mm)

A	22.30-23.20	F	10.80-11.20
B	16.30-16.50	G	10.50-11.00
C	17.00-17.70	H	18.90-19.70
D	8.25-8.55	J	4.30-5.10
E	—	K	14.06-14.54

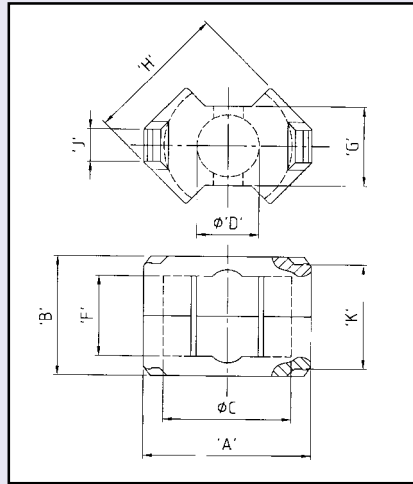

RM 8 SOLID 29-810-

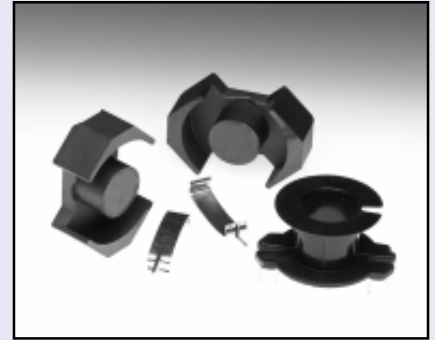

Core Parameters

In accordance with IEC Document 60205.

Parameter	Σ/A	Effective Length	Effective Area	Minimum Area	Effective Volume
Symbol	C_1	l_e	A_e	A_{min}	V_e
Value	0.59mm ⁻¹	38.0mm	64.0mm ²	55.0mm ²	2430.0mm ³

Electrical Specification

Material	A_L Value	Tolerance	Gap Length	Eff. Permeability	Part Number
F9	5700	+30/-20%	-	2675	29-810-36
F10	8375	+30/-20%	-	3930	29-810-37
F39	12500	+40/-30%	-	5870	29-810-39
F44	2905	+30/-20%	-	1365	29-810-44
F45	3300	+30/-20%	-	1550	29-810-45
F5A	4000	+30/-20%	-	1880	29-810-49
F44	100	±5%	0.70	47	29-811-44*
F44	160	±5%	0.40	75	29-812-44*
F44	250	±5%	0.25	117	29-813-44*
F44	315	±5%	0.15	188	29-814-44*

Part numbers refer to half cores.

*Part number refers to a pair of cores.

Bobbins/Coil Formers

Mounting	No. of Sections	Pins	Part Number
Vertical (Z)	1	8	60-792-64
Vertical (AS)	1	12	60-793-64

Other pin lengths and versions may be listed at the end of this section

Clip

Part Number
76-022-95

RM 10

29-830-

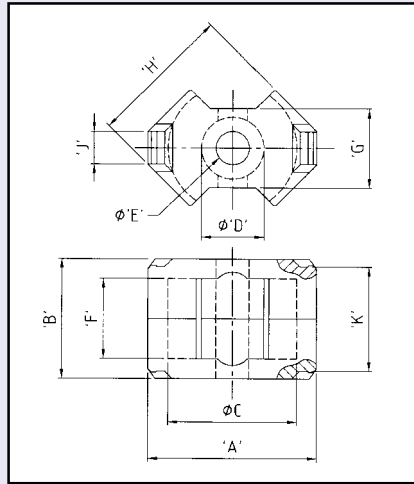
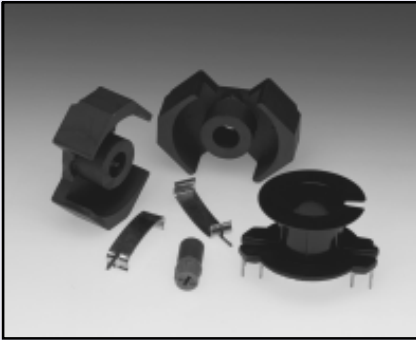

Core Dimensions (mm)

A	27.20 - 28.40	F	12.40 - 13.00
B	18.50 - 18.70	G	13.00 - 13.50
C	21.20 - 22.10	H	23.60 - 24.70
D	10.50 - 10.90	J	5.00 - 5.20
E	5.40 - 5.60	K	15.96 - 16.94

Core Parameters

In accordance with IEC Document 60205.

Parameter	Σ/A	Effective Length	Effective Area	Minimum Area	Effective Volume
Symbol	C_1	l_e	A_e	A_{min}	V_e
Value	0.50mm ⁻¹	42.00mm	83.00mm ²	-	3470.00mm ³

Electrical Specification

Material	A_L Value	Tolerance	Gap Length	Eff. Permeability	Part Number
P11	3960	+30/-20%	-	1575	29-830-41
F58	1600	+30/-20%	-	635	29-830-58
F58	63	±3%	2.60	25	29-8303-58*
F58	100	±3%	1.50	40	29-8304-58*
P11	160	±3%	0.90	64	29-8305-41*
P11	250	±3%	0.55	99	29-8306-41*
P11	400	±3%	0.21	159	29-8308-41*
P11	630	±3%	0.13	250	29-8309-41*
P11	1000	±3%	0.08	398	29-8310-41*

Part numbers refer to half cores.
Non adjustable type may be available on request.

*Part number refers to a pair of cores fitted with a nut for adjustable inductance assemblies.

Bobbins/Coil Formers

Style	No. of Sections	Pins	Part Number
Vertical (Z)	1	8	60-822-64
Vertical (AS)	1	12	60-823-64

Other pin lengths or variation may be listed at the end of this section

Adjusters

A_L Value	Part Number
63/100/160/250	64-8104-66
400/630	64-4843-66
1000	64-4845-66
Clip	76-023-95



Core Dimensions (mm)

A	27.20-28.40	F	12.40-13.00
B	18.50-18.70	G	13.00-13.50
C	21.20-22.10	H	23.60-24.70
D	10.50-10.90	J	5.00-5.20
E	—	K	15.96-16.44

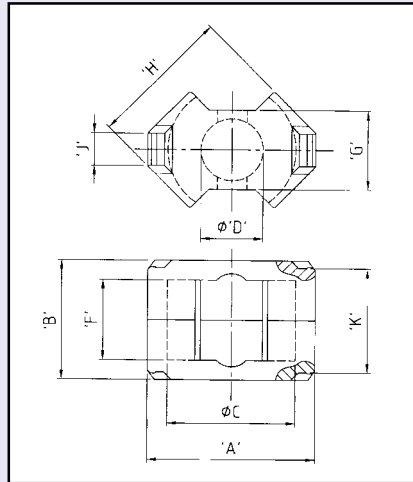

RM 10 SOLID 29-850-

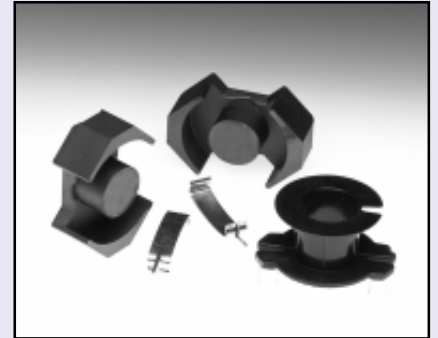

Core Parameters

In accordance with IEC Document 60205.

Parameter	Σ/A	Effective Length	Effective Area	Minimum Area	Effective Volume
Symbol	C_1	l_e	A_e	A_{min}	V_e
Value	0.45mm ⁻¹	44.0mm	98.0mm ²	90.0mm ²	4310.0mm ³

Electrical Specification

Material	A_L Value	Tolerance	Gap Length	Eff. Permeability	Part Number
F9	7875	+30/-20%	-	2820	29-850-36
F10	11000	+30/-20%	-	3940	29-850-37
F39	16000	+40/-30%	-	5730	29-850-39
F44	3800	+30/-20%	-	1360	29-850-44
F45	4200	+30/-20%	-	1505	29-850-45
F5A	4490	+30/-20%	-	1610	29-850-49
F44	160	±5%	0.90	57	29-862-44*
F44	250	±5%	0.55	89	29-863-44*
F44	400	±5%	0.21	143	29-865-44*
F44	630	±5%	0.13	225	29-866-44*

Part numbers refer to half cores.

*Part number refers to a pair of cores.

Bobbins/Coil Formers

Style	No. of Sections	Pins	Part Number
Vertical (Z)	1	8	60-822-64
Vertical (AS)	1	12	60-823-64

Other pin lengths and versions may be listed at the end of this section

Clip

Part Number
76-023-95

RM 12i SOLID

29-940-

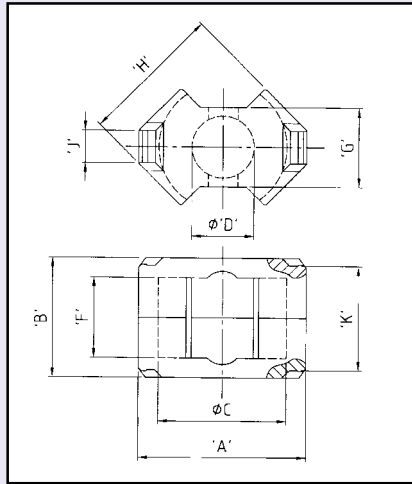
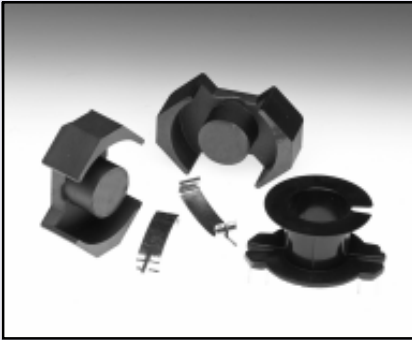

Core Dimensions (mm)

A	36.10 - 37.40	F	16.80 - 17.70
B	24.30 - 24.60	G	15.60 - 16.10
C	25.00 - 26.00	H	27.70 - 28.80
D	12.40 - 12.80	J	4.90 - 5.10
E	—	K	21.40 - 21.98

Core Parameters

In accordance with IEC Document 60205.

Parameter	$\Sigma I/A$	Effective Length	Effective Area	Minimum Area	Effective Volume
Symbol	C_1	l_e	A_e	A_{min}	V_e
Value	0.388mm ⁻¹	56.60mm	146.00mm ²	125mm ²	8340.00mm ³

Electrical Specification

Material	A_L Value	Tolerance	Gap Length	Eff. Permeability	Part Number
F47	4750	+30/-20%	-	1465	29-940-47
F44	5000	+30/-20%	-	1545	29-940-44
F5A	5800	+30/-20%	-	1790	29-940-49
F5A	160	±5%	1.50	49	29-941-49*
F5A	250	±5%	0.90	77	29-942-49*
F5A	400	±5%	0.50	123	29-943-49*

Part numbers refer to half cores.

*Part number refers to a pair of cores.

NOTE: This core range now complies with the new industrial requirements for power handling and should be ordered as replacements for previous RM12 cores supplied under Part no's. 29-930-xx to 29-939-xx.

The clips 76-030-95 are also **not** compatible with this new range.

Bobbins/Coil Formers

Style	No. of Sections	Pins	Part Number
Vertical (AS)	1	12	60-930-64
Vertical (DIL)	1	12	60-940-76

Clip

Part Number
76-085-95

Other pin lengths or variation may be listed at the end of this section



Core Dimensions (mm)

A	40.80-42.40	F	20.80-21.40
B	30.00-30.20	G	18.40-19.00
C	29.00-30.20	H	33.50-34.70
D	14.50-15.00	J	5.60-5.80
E	—	K	26.80-27.28

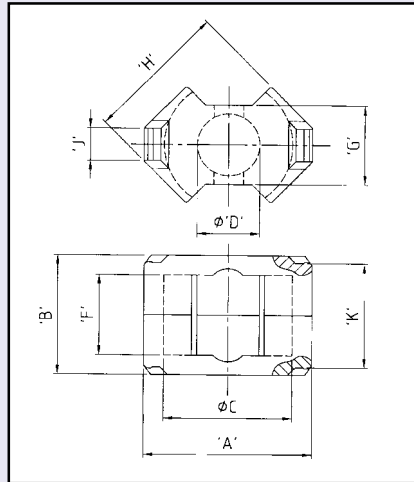

RM 14i SOLID 29-980-

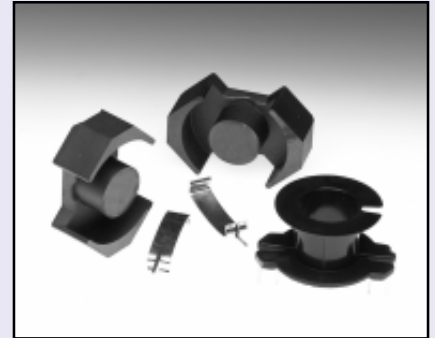

Core Parameters

In accordance with IEC Document 60205.

Parameter	$\Sigma I/A$	Effective Length	Effective Area	Minimum Area	Effective Volume
Symbol	C_1	l_e	A_e	A_{min}	V_e
Value	0.353mm ⁻¹	70.0mm	198.0mm ²	168.0mm ²	13,900.0mm ³

Electrical Specification

Material	A_L Value	Tolerance	Gap Length	Eff. Permeability	Part Number
F47	5400	+30/-20%	-	1520	29-980-47
F5A	6600	+30/-20%	-	1855	29-980-49
F5A	250	±5%	1.40	70	29-981-49*
F5A	400	±5%	0.80	112	29-982-49*
F5A	630	±5%	0.47	177	29-983-49*
F5A	1000	±5%	0.27	281	29-984-49*

Part numbers refer to half cores.

*Part number refers to a pair of cores.

NOTE: This core range now complies with the new industrial requirements for power handling and should be ordered as replacements for previous RM14 cores supplied under Part nos. 29-880-xx to 29-890-xx.

The clips 76-029-95 are also **not** compatible with this new range.

Bobbins/Coil Formers

Style	No. of Sections	Pins	Part Number
Vertical (AS)	1	12	60-882-64
Vertical (DIL)	1	12	60-990-76

Other pin lengths and versions may be listed at the end of this section

Clip

Part Number
76-086-95