

### FEATURES

- ◆ Resolution of up to 8,192 angle steps per sine period
- ◆ Binary and decimal resolution settings, e.g. 500, 512, 1000, 1024; programmable angle hysteresis
- ◆ Count-safe vector follower principle, real-time system with 70 MHz sampling rate
- ◆ Conversion time of just 250 ns including amplifier settling
- ◆ Direct sensor connection; selectable input gain
- ◆ Input frequency of up to 250 kHz
- ◆ Signal conditioning for offset, amplitude and phase
- ◆ A/B quadrature signals of up to 3.75 MHz with adjustable minimum transition distance
- ◆ Zero signal processing, adjustable in index position and width
- ◆ Absolute angle output via fast serial interface (BiSS, SSI)
- ◆ Permanent bidirectional memory access to parameters and OEM data by BiSS C
- ◆ Period counting with up to 24 bits
- ◆ Error monitoring of frequency, amplitude and configuration
- ◆ Device setup from serial EEPROM or using BiSS
- ◆ ESD protection and TTL-/CMOS-compatible outputs

### APPLICATIONS

- ◆ Interpolator IC for angle resolution from sine/cosine sensor signals
- ◆ Optical encoders
- ◆ MR sensor systems

### PACKAGES



**TSSOP20**  
RoHS compliant

### BLOCK DIAGRAM

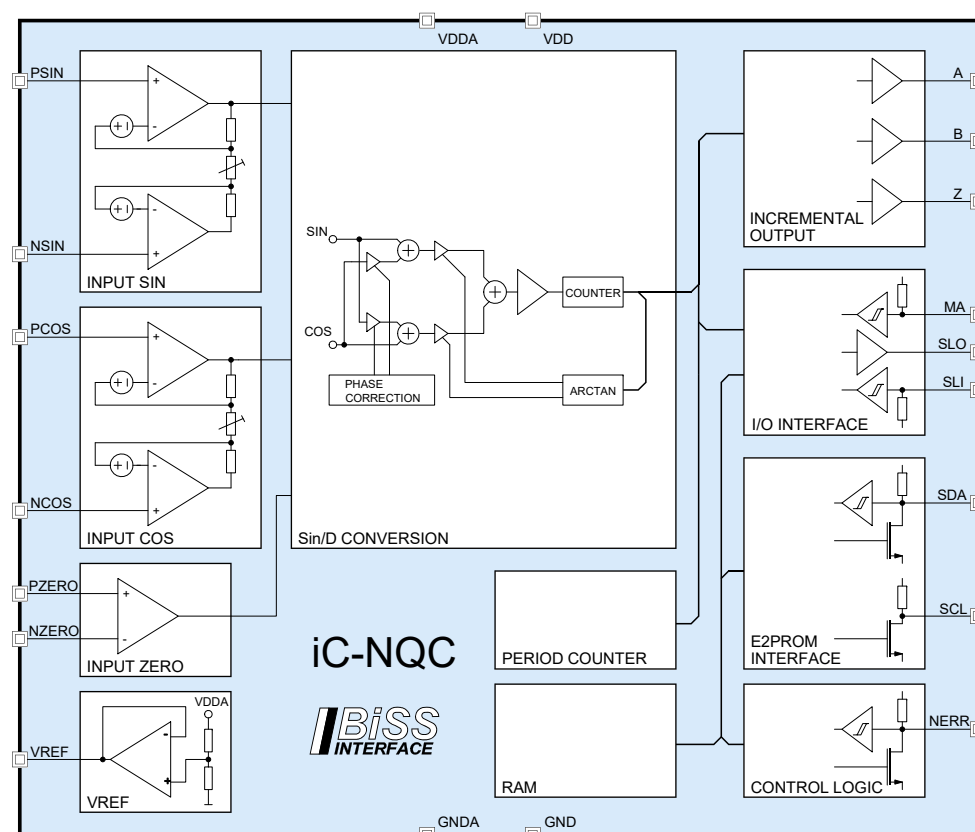

### DESCRIPTION

iC-NQC is a monolithic A/D converter which, by applying a count-safe vector follower principle, converts sine/cosine sensor signals with a selectable resolution and hysteresis into angle position data.

This absolute value is output via a bidirectional, synchronous-serial I/O interface in BiSS C protocol and trails a master clock rate of up to 10 Mbit/s. Alternatively, this value can be output so that it is compatible with SSI in Gray or binary code, with or without error bits. The device also supports double transmission in SSI ring mode.

Signal periods are logged quickly by a 24-bit period counter that can supplement the output data with an upstream multiturn position value.

At the same time any changes in angle are converted into incremental A QUAD B signals. Here, the minimum transition distance can be stipulated and adapted to suit the system on hand (cable length, external counter). A synchronized zero index Z is generated if enabled by PZERO and NZERO.

The front-end amplifiers are configured as instrumentation amplifiers, permitting sensor bridges to be directly connected without the need for external resis-

tors. Various programmable D/A converters are available for the conditioning of sine/cosine sensor signals with regard to offset, amplitude ratio and phase errors (offset compensation by 8-bit DAC, gain ratio by 5-bit DAC, phase compensation by 6-bit DAC).

The front-end gain can be set in stages graded to suit all common complementary sensor signals of approximately 20 mVpp to 1.5 Vpp and also non-complementary sensor signals of 40 mVpp to 3 Vpp, respectively.

The device can be configured using two bidirectional interfaces, the EEPROM interface from a serial EEPROM with I<sup>2</sup>C interface, or the I/O interface in BiSS C protocol. Free storage space on the EEPROM can be accessed via BiSS for the storage of additional data.

After a low voltage reset, iC-NQC reads in the configuration data including the check sum (CRC) from the EEPROM and repeats the process if a CRC error is detected.

The device described here is a multifunctional iC that contains integrated BiSS C interface components. The BiSS C process is protected by patent DE 10310622 B4 owned by iC-Haus GmbH and its application requires the conclusion of a license (free of charge).

**Download the license at**  
[www.biss-interface.com/bua](http://www.biss-interface.com/bua)

**CONTENTS**

<b>PACKAGING INFORMATION</b>	<b>4</b>	<b>TEST FUNCTIONS</b>	<b>19</b>
PIN CONFIGURATION		<b>I/O INTERFACE: BiSS C PROTOCOL</b>	<b>20</b>
TSSOP20 4.4 mm, lead pitch 0.65 mm . . . . .	4	Interface Parameters With BiSS C Protocol . . . . .	20
PACKAGE DIMENSIONS . . . . .	5	Example of BiSS Data Output . . . . .	21
<b>ABSOLUTE MAXIMUM RATINGS</b>	<b>6</b>	Register Communication . . . . .	21
<b>THERMAL DATA</b>	<b>6</b>	Internal Reset Function . . . . .	21
<b>ELECTRICAL CHARACTERISTICS</b>	<b>7</b>	Short BiSS Timeout . . . . .	21
CHARACTERISTICS: Diagrams . . . . .	9	<b>I/O INTERFACE: SSI Protocol</b>	<b>23</b>
<b>OPERATING REQUIREMENTS</b>	<b>10</b>	Examples of SSI Data Output . . . . .	24
I/O Interface . . . . .	10	<b>EEPROM INTERFACE</b>	<b>25</b>
<b>PARAMETER and REGISTER</b>	<b>11</b>	Example of CRC Calculation Routine . . . . .	25
<b>SIGNAL CONDITIONING</b>	<b>12</b>	<b>STARTUP BEHAVIOR</b>	<b>26</b>
<b>CONVERTER FUNCTIONS</b>	<b>13</b>	Startup With A Configured EEPROM . . . . .	26
<b>MAXIMUM POSSIBLE CONVERTER FREQUENCY</b>	<b>14</b>	Startup Without An EEPROM . . . . .	26
Serial Data Output . . . . .	14	Initialization After Configuration Failure . . . . .	26
Incremental Output to A, B and Z . . . . .	15	<b>APPLICATION NOTES</b>	<b>28</b>
<b>INCREMENTAL SIGNALS</b>	<b>16</b>	Principle Input Circuits . . . . .	28
<b>SIGNAL MONITORING and ERROR MESSAGES</b>	<b>18</b>	Input Circuit for Sine Encoders (1 Vpp) . . . . .	28
		Basic Circuit for MR Sensors . . . . .	29
		<b>EVALUATION BOARD</b>	<b>29</b>
		<b>DESIGN REVIEW: Function Notes</b>	<b>30</b>
		<b>REVISION HISTORY</b>	<b>31</b>

### PACKAGING INFORMATION TSSOP20 (according to JEDEC Standard)

#### PIN CONFIGURATION

TSSOP20 4.4 mm, lead pitch 0.65 mm

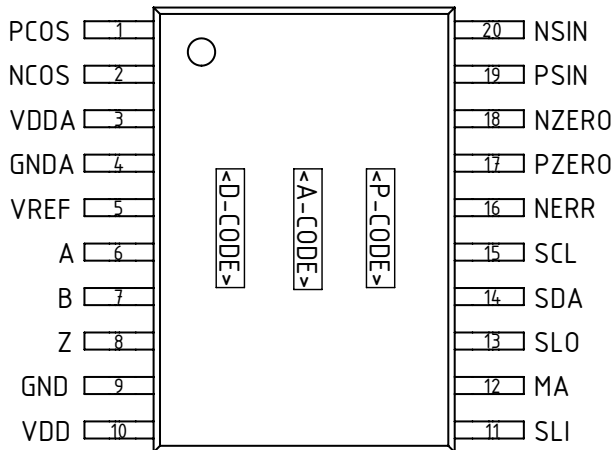

#### PIN FUNCTIONS

No.	Name	Function
1	PCOS	Input Cosine +
2	NCOS	Input Cosine -
3	VDDA <sup>1</sup>	+5 V Supply Voltage (analog)
4	GNDA <sup>1</sup>	Ground (analog)
5	VREF	Reference Voltage Output
6	A	Incremental Output A Analog signal COS+ (TMA mode) PWM signal for Offset Sine (calib.)
7	B	Incremental Output B Analog signal COS- (TMA mode) PWM signal for Offset Cosine (calib.)
8	Z	Incremental Output Z PWM signal for Phase/Ratio (calib.)
9	GND	Ground
10	VDD	+5 V Supply Voltage (digital)
11	SLI <sup>2</sup>	I/O Interface, data input
12	MA	I/O Interface, clock line
13	SLO	I/O Interface, data output
14	SDA	EEPROM interface, data line Analog signal SIN+ (TMA mode)
15	SCL <sup>3</sup>	EEPROM interface, clock line Analog signal SIN- (TMA mode)
16	NERR	Error Input/Output, active low
17	PZERO	Input Zero Signal +
18	NZERO	Input Zero Signal -
19	PSIN	Input Sine +
20	NSIN	Input Sine -

IC top marking: <P-CODE> = product code, <A-CODE> = assembly code (subject to changes), <D-CODE> = date code (subject to changes);

<sup>1</sup> External connections linking VDDA to VDD and GND to GNDA are required.

<sup>2</sup> If only a single iC-NQC is used and no chain circuitry of multiple BiSS slaves, pin SLI can remain unwired or can be linked to ground (GND).

<sup>3</sup> It is not permissible to pull down pin SCL during power-up.

# iC-NQC

13-bit Sin/D CONVERTER WITH SIGNAL CALIBRATION



Rev E1, Page 5/32

## PACKAGE DIMENSIONS

SIDE

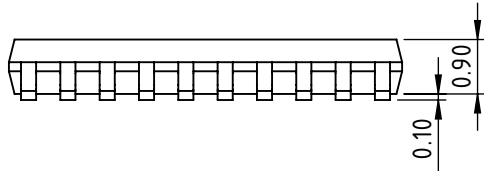

FRONT

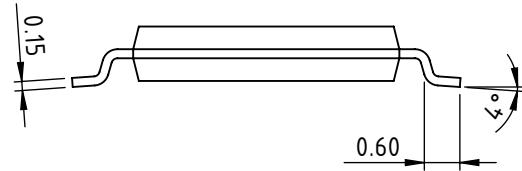

TOP

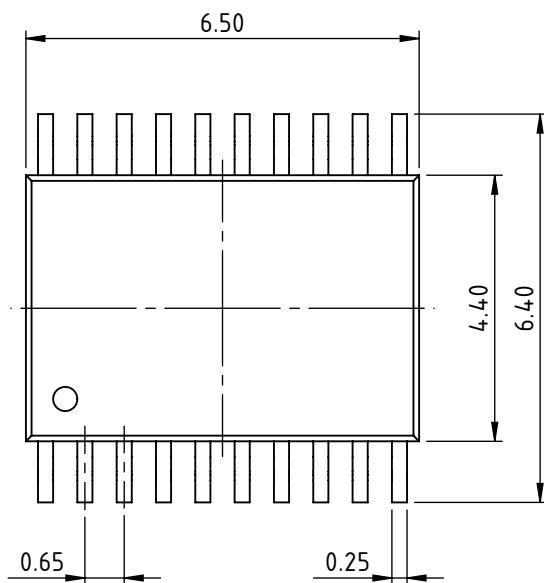

RECOMMENDED PCB-FOOTPRINT

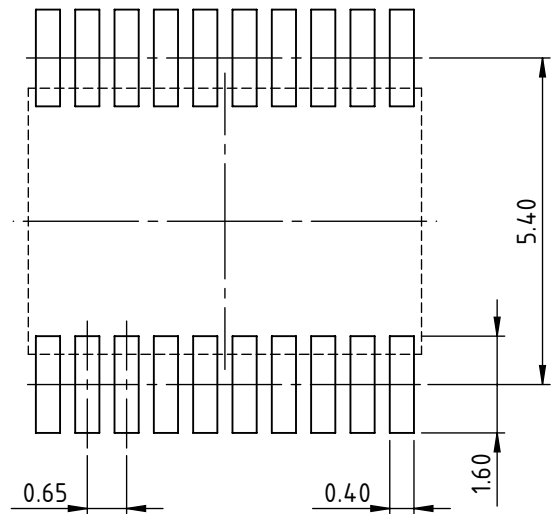

All dimensions given in mm.  
Tolerances of form and position according to JEDEC MO-153

drb\_fssop20-1\_pack\_1, 8:1

### ABSOLUTE MAXIMUM RATINGS

These ratings do not imply permissible operating conditions; functional operation is not guaranteed. Exceeding these ratings may damage the device.

Item No.	Symbol	Parameter	Conditions	Min.   Max.		Unit
				Min.	Max.	
G001	VDDA	Voltage at VDDA		-0.3	6	V
G002	VDD	Voltage at VDD		-0.3	6	V
G003	Vpin()	Voltage at PSIN, NSIN, PCOS, NCOS, PZERO, NZERO, VREF, NERR, SCL, SDA, MA, SLI, SLO, A, B, Z	$V() < VDDA + 0.3\text{ V}$ $V() < VDD + 0.3\text{ V}$	-0.3	6	V
G004	I <sub>mx</sub> (VDDA)	Current in VDDA		-50	50	mA
G005	I <sub>mx</sub> (GNDA)	Current in GNDA		-50	50	mA
G006	I <sub>mx</sub> (VDD)	Current in VDD		-50	50	mA
G007	I <sub>mx</sub> (GND)	Current in GND		-50	50	mA
G008	I <sub>mx</sub> ()	Current in PSIN, NSIN, PCOS, NCOS, PZERO, NZERO, VREF, NERR, SCL, SDA, MA, SLI, SLO, A, B, Z		-10	10	mA
G009	I <sub>lu</sub> ()	Pulse Current in all pins (Latch-up Strength)	according to Jedec Standard No. 78; T <sub>a</sub> = 25 °C, pulse duration to 10 ms, VDDA = VDDA <sub>max</sub> , VDD = VDD <sub>max</sub> , V <sub>lu</sub> () = (-0.5...+1.5) × V <sub>pin</sub> () <sub>max</sub>	-100	100	mA
G010	V <sub>d</sub> ()	ESD Susceptibility at all pins	HBM 100 pF discharged through 1.5 kΩ		2	kV
G011	T <sub>j</sub>	Junction Temperature		-40	150	°C
G012	T <sub>s</sub>	Storage Temperature Range		-40	150	°C

### THERMAL DATA

Operating Conditions: VDDA = VDD = 5 V ±10 %

Item No.	Symbol	Parameter	Conditions	Min.   Typ.   Max.			Unit
				Min.	Typ.	Max.	
T01	T <sub>a</sub>	Operating Ambient Temperature Range  (extended temperature range of -40 to 125 °C available on request)		-25		85	°C

All voltages are referenced to ground unless otherwise stated.

All currents flowing into the device pins are positive; all currents flowing out of the device pins are negative.

### ELECTRICAL CHARACTERISTICS

Operating Conditions: VDDA = VDD = 5 V  $\pm$ 10 %, Tj = -40 ... 125 °C, unless otherwise stated.

Item No.	Symbol	Parameter	Conditions				Unit
				Min.	Typ.	Max.	
<b>Total Device</b>							
Functionality and parameters beyond the operating conditions (with reference to independent voltage supplies, for instance) are to be verified within the individual application using FMEA methods.							
001	VDDA, VDD	Permissible Supply Voltage		4.5		5.5	V
002	I(VDDA)	Supply Current in VDDA	fin() = 200 kHz; A, B, Z open			15	mA
003	I(VDD)	Supply Current in VDD	fin() = 200 kHz; A, B, Z open			20	mA
004	Von	Turn-on Threshold VDDA, VDD		3.2		4.4	V
005	Vhys	Turn-on Threshold Hysteresis		200			mV
006	Vc()hi	Clamp Voltage hi at PSIN, NSIN, PCOS, NCOS, PZERO, NZERO, VREF	Vc()hi = V() - VDDA; I() = 1 mA, other pins open	0.3		1.6	V
007	Vc()lo	Clamp Voltage lo at PSIN, NSIN, PCOS, NCOS, PZERO, NZERO, VREF, NERR, SCL, SDA, MA, SLI, SLO, A, B, Z	I() = -1 mA, other pins open	-1.6		-0.3	V
008	Vc()hi	Clamp Voltage hi at NERR, SCL, SDA, MA, SLI, SLO, A, B, Z	Vc()hi = V() - VDD; I() = 1 mA, other pins open	0.3		1.6	V
<b>Input Amplifiers and Signal Inputs PSIN, NSIN, PCOS, NCOS</b>							
101	Vos()	Input Offset Voltage	Vin() and G() in accordance with Table GAIN; G $\geq$ 20 G < 20	-10 -15		10 15	mV mV
102	TCos	Input Offset Voltage Temperature Drift	see 101		$\pm$ 10		$\mu$ V/K
103	lin()	Input Current	V() = 0 V ... VDDA	-50		50	nA
104	GA	Gain Accuracy	G() in accordance with Table GAIN	95		102	%
105	GArel	Gain SIN/COS Ratio Accuracy	G() in accordance with Table GAIN	97		103	%
106	fhc	Cut-off Frequency	G = 80 G = 2.667	150 630			kHz kHz
107	SR	Slew Rate	G = 80 G = 2.667	2.3 8.0			V/ $\mu$ s V/ $\mu$ s
108	Vout()tma	Permissible Internal Signal Level (Full-Scale Signal)	TMA mode: analog signal at A, B, SCL, SDA	0.5		VDDA - 0.5	V
<b>Sine-To-Digital Conversion</b>							
201	AAabs	Absolute Angle Accuracy without calibration	referred to 360° input signal, G = 2.667, Vin = 1.5 Vpp, HYS = 0	-1.0		1.0	DEG
202	AAabs	Absolute Angle Accuracy after calibration	referred to 360° input signal, HYS = 0, internal signal amplitude of 2 ... 4 Vpp	-0.5	$\pm$ 0.35	+0.5	DEG
203	AArel	Relative Angle Accuracy	referred to signal periods at A, resp. B (see Fig. 1); G = 2.667, Vin = 1.5 Vpp, SELRES = 1024, FCTR = 0x0004 ... 0x00FF, fin < finmax (see Table 15)	-10		10	%
<b>Reference Voltage Output VREF</b>							
801	VREF	Reference Voltage	I(VREF) = -1 mA ... +1 mA	48		52	% VDDA
<b>Oscillator</b>							
A02	fosc()	Oscillator Frequency	presented at pin SCL with subdivision of 2048; VDDA = VDD = 5 V $\pm$ 10 % VDDA = VDD = 5 V	56 58	74	92 86	MHz MHz
A03	TCosc	Oscillator Frequency Temperature Drift	VDDA = VDD = 5 V		-0.1		%/K
A04	VCosc	Oscillator Frequency Power Supply Dependence			+9		%/V

### ELECTRICAL CHARACTERISTICS

Operating Conditions: VDDA = VDD = 5 V ±10 %, Tj = -40 ... 125 °C, unless otherwise stated.

Item No.	Symbol	Parameter	Conditions				Unit
				Min.	Typ.	Max.	
<b>Zero Signal Enable Inputs PZERO, NZERO</b>							
B01	Vos()	Input Offset Voltage	V() = Vcm()	-20		20	mV
B02	Iin()	Input Current	V() = 0 V ... VDDA	-50		50	nA
B03	Vcm()	Common-Mode Input Voltage Range		1.4		VDDA -1.5	V
B04	Vdm()	Differential Input Voltage Range		0		VDDA	V
<b>Incremental Outputs A, B, Z and I/O Interface Output SLO</b>							
D01	Vs()hi	Saturation Voltage hi	Vs()hi = VDD - V(); I() = -4 mA			0.4	V
D02	Vs()lo	Saturation Voltage lo	I() = 4 mA			0.4	V
D03	tr()	Rise Time	CL() = 50 pF			60	ns
D04	tf()	Fall Time	CL() = 50 pF			60	ns
D05	RL()	Permissible Load at A, B	TMA = 1 (calibration mode)	1			MΩ
D06	t <sub>out</sub> ()	Slave Timeout at SLO	refer to Figure 3 and 4; TOA = 0, TIMO = 0 (long) TOA = 0, TIMO = 1 (short)	1472/f <sub>osc</sub> 96/f <sub>osc</sub>		1504/f <sub>osc</sub> 128/f <sub>osc</sub>	μs μs
D07	t <sub>out</sub> ()	Adaptive Slave Timeout at SLO	related to the clock timing, refer to Figure 5; TOA = 1 (adaptive)	64/f <sub>osc</sub>	t <sub>init</sub> + 128/f <sub>osc</sub>	1504/f <sub>osc</sub>	μs
<b>I/O Interface Inputs MA, SLI</b>							
E01	Vt()hi	Threshold Voltage hi				2	V
E02	Vt()lo	Threshold Voltage lo		0.8			V
E03	Vt()hys	Hysteresis	Vt()hys = Vt()hi - Vt()lo	300			mV
E04	Ipu(MA)	Pull-up Current in MA	V() = 0 ... VDD - 1 V	-240	-120	-25	μA
E05	Ipd(SLI)	Pull-down Current in SLI	V() = 1 ... VDD	20	120	300	μA
E06	fclk(MA)	Permissible MA Clock Frequency	SSI protocol BiSS protocol			4 10	MHz MHz
E09	tbusy_r	Processing Time Register Access (delay of start bit)	with read access to EEPROM			2	ms
E10	tidle	Interface Blocking Time	powering up with no EEPROM		1	1.5	ms
<b>EEPROM Interface Inputs SDA and Error Input NERR</b>							
F01	Vt()hi	Threshold Voltage hi				2	V
F02	Vt()lo	Threshold Voltage lo		0.8			V
F03	Vt()hys	Hysteresis	Vt()hys = Vt()hi - Vt()lo	300			mV
F04	tbusy()cfg	Duration of Startup Configuration	error free EEPROM access		5	7	ms
<b>EEPROM Interface Outputs SDA, SCL and Error Output NERR</b>							
G01	f()	Write/Read Clock at SCL			20	100	kHz
G02	Vs()lo	Saturation Voltage lo	I() = 4 mA			0.45	V
G03	Ipu()	Pull-up Current	V() = 0 ... VDD - 1 V	-600	-300	-75	μA
G04	ft()	Fall Time	CL() = 50 pF			60	ns
G05	tmin()lo	Min. Duration Of Error Indication at NERR (lo signal)	MA = hi, no BiSS access, amplitude or frequency error	10			ms
G06	Tpwm()	Cycle Duration Of Error Indication at NERR	fosc() subdivided 2 <sup>22</sup>		60.7		ms
G07	tw()lo	Duty Cycle Of Error Indication at NERR	signal duration low to high; AERR = 0, during amplitude error FERR = 0, during frequency error		75 50		% %
G08	RL()	Permissible Load at SDA, SCL	TMA = 1 (calibration mode)	1			MΩ



### ELECTRICAL CHARACTERISTICS

Operating Conditions:  $V_{DDA} = V_{DD} = 5\text{ V} \pm 10\%$ ,  $T_j = -40 \dots 125\text{ }^\circ\text{C}$ , unless otherwise stated.

Item No.	Symbol	Parameter	Conditions	Min.	Typ.	Max.	Unit
<b>Signal Monitoring</b>							
H01	Vth	Voltage Threshold for Monitoring of Minimal Amplitude	$V_{DDA} = 5\text{ V}$ , SELAMPL = 0, AMPL = 0x00, PHI: 0°, 90°, 180°, 270° AMPL = 0x01, PHI: 0° AMPL = 0x02, PHI: 0° AMPL = 0x03, PHI: 0°	2.8 3.0 3.2 3.4	3.0 3.2 3.4 3.6	3.2 3.4 3.6 3.8	V V V V
H02	Vthmax	Upper Voltage Threshold for Monitoring of $\text{Sin}^2 + \text{Cos}^2$	$V_{DDA} = 5\text{ V}$ , SELAMPL = 1, AMPL = 0x04...0x07, PHI: 0°, 45°...315°	3.35	4.5	4.95	V
H03	Vthmin	Lower Voltage Threshold for Monitoring of $\text{Sin}^2 + \text{Cos}^2$	$V_{DDA} = 5\text{ V}$ , SELAMPL = 1, AMPL = 0x04, PHI: 0°, 45°...315° AMPL = 0x05, PHI: 45° AMPL = 0x06, PHI: 45° AMPL = 0x07, PHI: 45°	0.2 0.6 1.1 1.6	1.0 1.5 2.0 2.5	1.5 2.0 2.5 3.0	V V V V

### CHARACTERISTICS: Diagrams

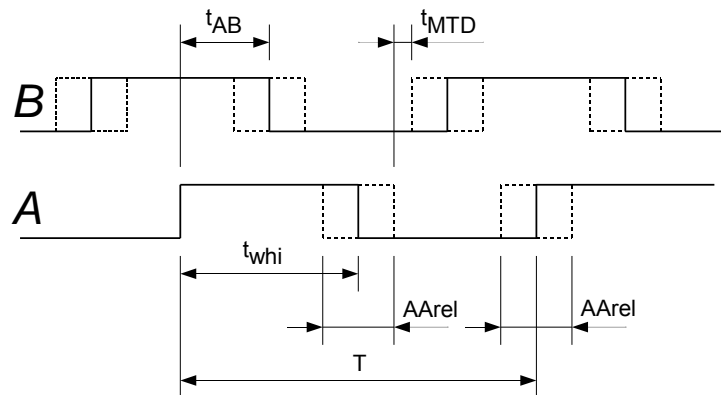

Figure 1: Definition of relative angle error and minimum transition distance

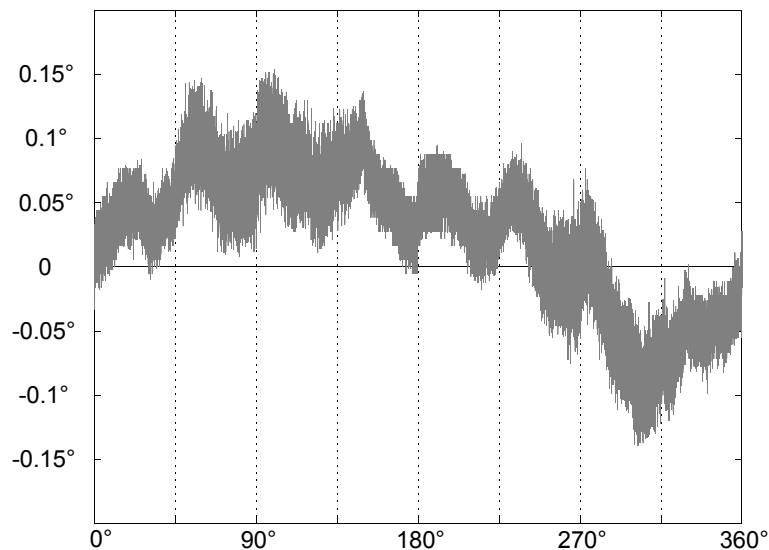

Figure 2: Typical residual absolute angle error after calibration.

### OPERATING REQUIREMENTS: I/O Interface

Operating Conditions: VDD = 5 V ±10 %, Ta = -25 ... 85 °C; input levels lo = 0 ... 0.45 V, hi = 2.4 V ... VDD

Item No.	Symbol	Parameter	Conditions	Min. / Max.		Unit
				Min.	Max.	
<b>SSI protocol</b>						
I001	$t_{frame}$	Permissible Frame Repetition		*	indefinite	
I002	$t_C$	Permissible Clock Period		250		ns
I003	$t_{L1}$	Clock Signal Hi-Level Duration		125	$t_{out}$	ns
I004	$t_{L2}$	Clock Signal Lo-Level Duration		125	$t_{out}$	ns
I005	$t_{RQ}$	Request Time	Clock low-level duration at MA input	125		ns
I006	$t_{P3}$	Output Propagation Delay	$RL(SLO) \geq 1\text{ k}\Omega$	10	50	ns
I007	$t_{out}$	Slave Timeout		see Elec. Char. D06		
<b>BiSS C protocol</b>						
I008	$t_{frame}$	Permissible Frame Repetition		*	indefinite	
I009	$t_C$	Permissible Clock Period		100		ns
I010	$t_{L1}$	Clock Signal Hi-Level Duration		50	$t_{out}$	ns
I011	$t_{L2}$	Clock Signal Lo-Level Duration		50	$t_{out}$	ns
I012	$t_{busy}$	Processing Time			180	ns
I013	$t_{P3}$	Output Propagation Delay	$RL(SLO) \geq 1\text{ k}\Omega$	10	50	ns
I014	$t_{out}$	Slave Timeout		see E.Char. D06, D07		
I015	$t_{S1}$	Setup Time: SLI stable before MA hi → lo		25		ns
I016	$t_{H1}$	Hold Time: SLI stable after MA hi → lo		10		ns

Note: \* Allow  $t_{out}$  to elapse.

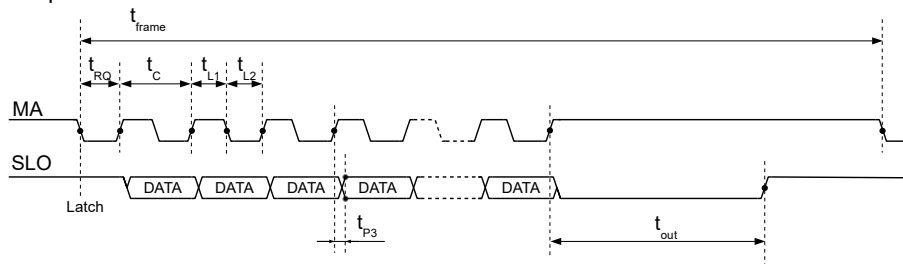

Figure 3: SSI protocol timing

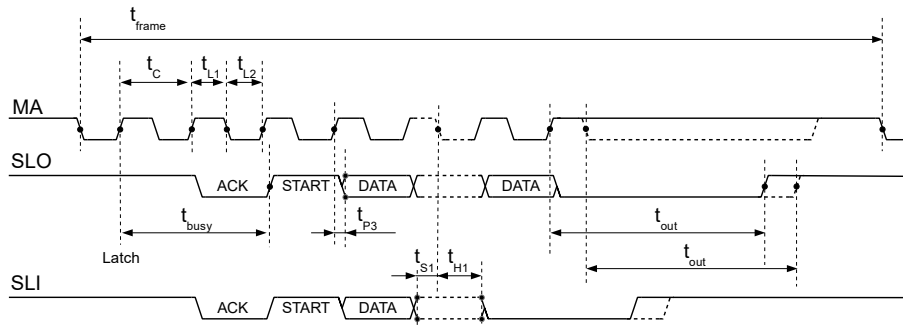

Figure 4: BiSS protocol timing

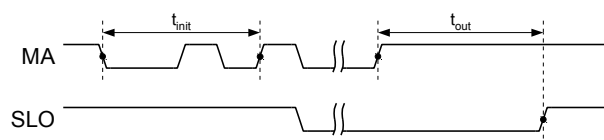

Figure 5: BiSS slave timeout

### PARAMETER and REGISTER

<b>Register Description, Overview</b> .....	Page 11	<b>Signal Monitoring</b>	
<b>Signal Conditioning</b> .....	Page 12	<b>and Error Messages</b> .....	Page 18
GAIN:	Gain Select	SELAMPL:	Amplitude Monitoring, function
SINOFFS:	Offset Calibration Sine	AMPL:	Amplitude Monitoring, thresholds
COSOFFS:	Offset Calibration Cosine	AERR:	Amplitude Error
REFOFFS:	Offset Calibration Reference	FERR:	Frequency Error
RATIO:	Amplitude Calibration	<b>Test Functions</b> .....	Page 19
PHASE:	Phase Calibration	TMODE:	Test Mode
<b>Converter Function</b> .....	Page 13	TMA:	Analog Test Mode
SELRES:	Resolution	<b>BiSS Interface</b> .....	Page 20
HYS:	Hysteresis	SELSSI:	Protocol Version
FCTR:	Max. Permissible Converter Frequency	TIMO, TOA:	Timeout
<b>Incremental Signals</b> .....	Page 16	TOS:	Timeout Short**
CFGABZ:	Output A, B, Z	M2S:	Data Output and Options
ROT:	Direction of Rotation	CRC6:	CRC Polynomial and Status Messages
CBZ:	24-bit Period Counter Configuration	NZB:	Zero Bit
ENRESDEL:	Output Delay A, B, Z	ENCDS:	Protocol Options
ZPOS:	Zero Signal Position	RPL:	Register Protection Settings
CFGZ:	Zero Signal Length	GRAY:	SSI Data Format
CFGAB:	Zero Signal Logic		

OVERVIEW								
Addr	Bit 7	Bit 6	Bit 5	Bit 4	Bit 3	Bit 2	Bit 1	Bit 0
0x00	ENCDS	M2S(1:0)		SELRES(4:0)				
0x01	HYS(2:0)			ZPOS(4:0)				
0x02	ENRESDEL	SELSSI	ROT	CBZ	CFGABZ(1:0)		CFGZ(1:0)	
0x03	CRC6	NZB	CFGAB(1:0)		RPL	0	AERR	FERR
0x04	FCTR(7:0)							
0x05	GRAY	FCTR(14:8)						
0x06	reserved*		TIMO	0	TMODE(2:0)		TMA	
0x07	reserved*				TOA	reserved*		
0x08	GAIN(3:0)				RATIO(3:0)			
0x09	SINOFFS(7:0)							
0x0A	COSOFFS(7:0)							
0x0B	PHASE(5:0)						REFOFFS	RATIO(4)
0x0C	reserved*					SELAMPL	AMPL(1:0)	
0x0D								
0x0E								
0x0F	CRC_E2P(7:0) - check value read from the EEPROM for addresses 0x00 to 0x0E							
0x10 - 0x1F	EEPROM 0x00 - 0x0F	Reserved EEPROM memory section: iC-NQC device configuration data.						
0x41 - 0x7F	0x31 - 0x6F	Reserved EEPROM memory section: BiSS C Slave Registers (device identifier 4E 51 43 35 00 00 69 43)						

Register contents are random when powering up without an EEPROM.

When no register protection is active, all registers permit read and write access (see RPL).

\*) Reserved registers must be programmed to zero. \*\*) For TOS see Table 42 on page 22.

Table 5: Register layout

### SIGNAL CONDITIONING

Input stages SIN and COS are configured as instrumentation amplifiers. The amplifier gain must be selected in accordance with the input signal amplitude and pro-

grammed to register GAIN according to the following table. Half of the supply voltage is available at VREF as a center voltage to enable the DC level to be adapted.

GAIN		Sine/Cosine Input Signal Levels Vin()			
Code	Amplification	Amplitude		Average value (DC)	
		Differential	Single-ended	Differential	Single-ended
0x0F	80.000	up to 50 mVpp	up to 100 mVpp	0.7 V ... VDDA - 1.2 V	0.8 V ... VDDA - 1.2 V
0x0E	66.667	up to 60 mVpp	up to 120 mVpp	0.7 V ... VDDA - 1.2 V	0.8 V ... VDDA - 1.2 V
0x0D	53.333	up to 75 mVpp	up to 0.15 Vpp	0.7 V ... VDDA - 1.2 V	0.8 V ... VDDA - 1.2 V
0x0C	40.000	up to 0.1 Vpp	up to 0.2 Vpp	1.2 V ... VDDA - 1.2 V	1.3 V ... VDDA - 1.3 V
0x0B	33.333	up to 0.12 Vpp	up to 0.24 Vpp	1.2 V ... VDDA - 1.2 V	1.3 V ... VDDA - 1.3 V
0x0A	28.571	up to 0.14 Vpp	up to 0.28 Vpp	0.7 V ... VDDA - 1.2 V	0.8 V ... VDDA - 1.3 V
0x09	26.667	up to 0.15 Vpp	up to 0.3 Vpp	1.2 V ... VDDA - 1.2 V	1.3 V ... VDDA - 1.3 V
0x08	20.000	up to 0.2 Vpp	up to 0.4 Vpp	0.7 V ... VDDA - 1.2 V	0.8 V ... VDDA - 1.3 V
0x07	14.287	up to 0.28 Vpp	up to 0.56 Vpp	1.2 V ... VDDA - 1.3 V	1.4 V ... VDDA - 1.4 V
0x06	10.000	up to 0.4 Vpp	up to 0.8 Vpp	1.2 V ... VDDA - 1.3 V	1.4 V ... VDDA - 1.5 V
0x05	8.000	up to 0.5 Vpp	up to 1 Vpp	0.8 V ... VDDA - 1.4 V	1.0 V ... VDDA - 1.6 V
0x04	6.667	up to 0.6 Vpp	up to 1.2 Vpp	0.8 V ... VDDA - 1.4 V	1.1 V ... VDDA - 1.7 V
0x03	5.333	up to 0.75 Vpp	up to 1.5 Vpp	0.9 V ... VDDA - 1.5 V	1.3 V ... VDDA - 1.9 V
0x02	4.000	up to 1 Vpp	up to 2 Vpp	1.2 V ... VDDA - 1.6 V	1.7 V ... VDDA - 2.1 V
0x01	3.333	up to 1.2 Vpp	up to 2.4 Vpp	1.2 V ... VDDA - 1.7 V	1.8 V ... VDDA - 2.3 V
0x00	2.667	up to 1.5 Vpp	up to 3 Vpp	1.3 V ... VDDA - 1.8 V	2.0 V ... VDDA - 2.6 V

Table 6: Input gain

SINOFFS Adr 0x09, Bit 7:0		
COSOFFS Adr 0x0A, Bit 7:0		
Code	Output Offset	Input Offset
0x00	0 V	0 V
0x01	-7.8125 mV	-7.8125* mV / GAIN
...	...	...
0x7F	-0.9922 V	-0.9922 V / GAIN
0x80	0 V	0 V
0x81	+7.8125 mV	+7.8125 mV / GAIN
...	...	...
0xFF	+0.9922 V	+0.9922 V / GAIN
Notes	*) With REFOFFS = 0x00 and VDDA = 5 V.	

Table 7: Sine/cosine offset calibration

REFOFFS Adr 0x0B, Bit 1	
Code	Reference Voltage
0x00	Dependent on VDDA (example of application: MR sensors)
0x01	Not dependent on VDDA (example of application: Sin/Cos encoders)

Table 8: Offset reference

RATIO Adr 0x0B, Bit 0, Adr 0x08, Bit 3:0			
Code	COS / SIN	Code	COS / SIN
0x00	1.0000	0x10	1.0000
0x01	1.0067	0x11	0.9933
...	...	...	...
0x0F	1.1	0x1F	0.9000

Table 9: Amplitude calibration

PHASE Adr 0x0B, Bit 7:2			
Code	Phase Shift	Code	Phase Shift
0x00	90°	0x20	90°
0x01	90.703125°	0x21	89.296875°
...	...	...	...
0x12	102.65625°	0x32	77.34375°
...	102.65625°	...	77.34375°
0x1F	102.65625°	0x3F	77.34375°

Table 10: Phase calibration

### CONVERTER FUNCTIONS

SELRES Adr 0x00, Bit 4:0		
Code	Binary Resolutions	Examples of Permissible Input Frequencies $f_{in_{max}}$ (FCTR 0x0004, 0x4302)
0x00	-	
0x01	-	
0x02	-	
0x03	8192	171 Hz, 1.14 kHz
0x04	4096	342 Hz, 2.28 kHz
0x05	2048	683 Hz, 4.56 kHz
0x06	1024	1.37 kHz, 9.1 kHz
0x07	512	2.73 kHz, 18.2 kHz
0x08	256	5.47 kHz, 36.5 kHz
0x09	128	10.9 kHz, 72.9 kHz
0x0A	64	21.9 kHz, 145.8 kHz
0x0B	32	43.7 kHz (max. 250 kHz)
0x0C	16	87.5 kHz (max. 250 kHz)
0x0D	8	175 kHz (max. 250 kHz)
0x0E	-	
0x0F	-	

Table 11: Binary resolutions

SELRES Adr 0x00, Bit 4:0		
Code	Decimal Resolutions	Examples of Permissible Input Frequencies $f_{in_{max}}$ (FCTR 0x0004, 0x4302)
0x10	2000	700 Hz, 4.67 kHz
0x11	1600	875 Hz, 5.83 kHz
0x12	1000	1.4 kHz, 9.33 kHz
0x13	800	1.75 kHz, 11.67 kHz
0x14	500	2.8 kHz, 18.67 kHz
0x15	400	3.5 kHz, 23.3 kHz
0x16	250 <sup>*1</sup>	5.6 kHz, 37.3 kHz
0x17	125 <sup>*1,2</sup>	5.6 kHz, 37.3 kHz
0x18	320	4.4 kHz, 29.2 kHz
0x19	160 <sup>*2</sup>	4.4 kHz, 29.2 kHz
0x1A	80 <sup>*4</sup>	4.4 kHz, 29.2 kHz
0x1B	40 <sup>*8</sup>	4.4 kHz, 29.2 kHz
0x1C	200	7.0 kHz, 46.7 kHz
0x1D	100 <sup>*2</sup>	7.0 kHz, 46.7 kHz
0x1E	50 <sup>*1,4</sup>	7.0 kHz, 46.7 kHz
0x1F	25 <sup>*1,8</sup>	7.0 kHz, 46.7 kHz
Notes	<sup>*1</sup> Not suitable for incremental output on A, B. <sup>*2,4,8</sup> The internal resolution is higher by a factor of 2, 4 or 8.	

Table 12: Decimal resolutions

HYS Adr 0x01, Bit 7:5			
Code	Hysteresis in degrees	Hysteresis in LSB	Absolute error*
0x00	0°		
0x01	0.0879°	1 LSB @ 12 bit	0.044°
0x02	0.1758°	1/2 LSB @ 10 bit	0.088°
0x03	0.3516°	1 LSB @ 10 bit	0.176°
0x04	0.7031°	1/2 LSB @ 8 bit	0.352°
0x05	1.4063°	1 LSB @ 8 bit	0.703°
0x06	5.625°		2.813°
0x07	45°	only recommended for calibration	22.5°
Notes	The digital angle hysteresis separates the converter's switch points between CW and CCW operation. It thus eliminates spurious AB output switching during stillstand if set sufficiently high related to the input noise.  *) Note that the resulting absolute error is equivalent to half the angle hysteresis. Use zero hysteresis for high accuracy serial BiSS or SSI output.		

Table 13: Hysteresis

### MAXIMUM POSSIBLE CONVERTER FREQUENCY

The converter frequency automatically adjusts to the value required by the input frequency and resolution. This value ranges from zero to a maximum dependent on the oscillator frequency that is set via register FCTR.

#### Serial Data Output

For BiSS or SSI output the maximum possible converter frequency can be adjusted to suit the maximum input frequency; an automatic converter resolution step-down feature can be enabled via the FCTR register. Should the input frequency exceed the frequency limit of the selected converter resolution, the LSB is kept stable and

not resolved any further; the interpolation resolution halves.

If the next frequency limit is overshoot, the LSB and LSB +1 are kept stable and so on. If the input frequency again sinks below this frequency threshold, fine resolution automatically returns.

With the programming of CRC6 = 1 a resolution step-down will be signalled via the BiSS warning bit.

Max. Possible Converter Frequency For Serial Data Output										
FCTR	Resolution Requirements			Protocol		Max. Input Frequency $f_{in\_max}$	Restrictions at high input frequency	Examples* $f_{in\_max}$ [kHz] at resol.		
	Min. Res.	bin	dec	BiSS	SSI			8192	1024	200
0x0004		X	X	X	X	$f_{osc}()_{min} / 40 / \text{Resolution}$	-	0.17	1.37	7.0
0x4102	$\geq 8$	X	X	X	X	$f_{osc}()_{min} / 24 / \text{Resolution}$	Rel. angle error 2x increased	0.28	2.3	11.7
0x4202	$\geq 16$	X	X	X	X	$2 \times f_{osc}()_{min} / 24 / \text{Res.}$	Rel. angle error 4x increased	0.57	4.6	23.3
0x4302	$\geq 32$	X	X	X	X	$4 \times f_{osc}()_{min} / 24 / \text{Res.}$	Rel. angle error 8x increased	1.14	9.1	46.7
0x4702	$\geq 64$	X	-	X	X	$8 \times f_{osc}()_{min} / 24 / \text{Res.}$	Resolution lowered by factor of 2	2.3	18.2	-
0x4B02	$\geq 128$	X	-	X	X	$16 \times f_{osc}()_{min} / 24 / \text{Res.}$	Res. lowered by factor of 2-4	4.6	36.5	-
0x4F02	$\geq 256$	X	-	X	X	$32 \times f_{osc}()_{min} / 24 / \text{Res.}$	Res. lowered by factor of 2-8	9.1	72.9	-
0x5302	$\geq 512$	X	-	X	X	$64 \times f_{osc}()_{min} / 24 / \text{Res.}$	Res. lowered by factor of 2-16	18.2	146	-
0x5702	$\geq 1024$	X	-	X	X	$128 \times f_{osc}()_{min} / 24 / \text{Res.}$	Res. lowered by factor of 2-32	36.5	250	-
0x5B02	$\geq 2048$	X	-	X	X	$256 \times f_{osc}()_{min} / 24 / \text{Res.}$	Res. lowered by factor of 2-64	72.9	-	-
0x5F02	$\geq 4096$	X	-	X	X	$512 \times f_{osc}()_{min} / 24 / \text{Res.}$	Res. lowered by factor of 2-128	146	-	-
0x6302	8192	X	-	X	X	$1024 \times f_{osc}()_{min} / 24 / \text{Res.}$	Res. lowered by factor of 2-256	250	-	-
Notes	*) Calculated with $f_{osc}()_{min}$ taken from Electrical Characteristics, item A02.									

Table 14: Maximum converter frequency for serial data output.

### Incremental Output to A, B and Z

Settings for the maximum possible converter frequency using register FCTR are governed by two criteria:

1. The maximum input frequency
2. System restrictions caused by slow counters or data transmission via cable

In this case it is sensible to preselect a minimum transition distance for the output signals. These settings

also make a suitable zero-delay digital glitch filter that acts on ESD impact on the sensor and keeps the output signals spike free through temporal separation, for example.

Serial data output is possible at any time in BiSS or SSI protocol. However, for the transfer of angle data to the output register the incremental output is halted for one period of the clock signal at pin MA.

1. Max. Possible Converter Frequency Defined By The Maximum Input Frequency									
FCTR	Output Frequency $f_{out} @ f_{in_{max}}$	Resolution Requirem.		Maximum Input Frequency $f_{in_{max}}$	Restrictions at high input frequency	Examples* $f_{in_{max}}$ [kHz] at resol.			
	A, B	bin	dec			8192	1024	200	
0x0004	325 kHz	X	X	$f_{osc}()min / 40 / Resolution$	None	0.17	1.37	7.0	
0x4102	542 kHz	X	X	$f_{osc}()min / 24 / Resolution$	Relative angle error 2x increased	0.28	2.3	11.7	
0x4202	1.08 MHz	X	X	$2 \times f_{osc}()min / 24 / Res.$	Relative angle error 4x increased	0.57	4.6	23.3	
0x4302	2.17 MHz	X	X	$4 \times f_{osc}()min / 24 / Res.$	Relative angle error 8x increased	1.14	9.1	46.7	
Notes	*) Calculated with $f_{osc}()min$ taken from Electrical Characteristics, item A02.								

Table 15: Maximum possible converter frequency for incremental A/B/Z output, defined by the maximum input frequency

2. Max. Possible Converter Frequency Defined By The Minimum Transition Distance						
FCTR	Output Frequency $f_{out} @ t_{MTD}$	Resolution Requirem.		Minimum Transition Distance at A, B $t_{MTD}$	Restrictions at high input frequency	Example* $t_{MTD}$ [µsec]
	A, B	bin	dec			
0x00FF	11.2 kHz	X	X	$2048 / f_{osc}()max$	None	22.3
0x00FE	11.27 kHz	X	X	$2040 / f_{osc}()max$	None	22.2
0x00FD	11.3 kHz	X	X	$2032 / f_{osc}()max$	None	22.1
...	...	...	...	...	...	...
0x0006	411 kHz	X	X	$56 / f_{osc}()max$	None	0.61
0x0005	479 kHz	X	X	$48 / f_{osc}()max$	None	0.52
0x0004	575 kHz	X	X	$40 / f_{osc}()max$	None	0.43
0x4102	958 kHz	X	X	$24 / f_{osc}()max$	Relative angle error 2x increased	0.26
0x4202	1.92 MHz	X	X	$12 / f_{osc}()max$	Relative angle error 4x increased	0.13
0x4302	3.83 MHz	X	X	$6 / f_{osc}()max$	Relative angle error 8x increased	0.065
Notes	*) Calculated with $f_{osc}()max$ taken from El.Char., item A02; transition distance output A vs. output B with same direction of rotation.					

Table 16: Maximum possible converter frequency for incremental A/B/Z output, defined by the minimum transition distance

### INCREMENTAL SIGNALS

CFGABZ	Adr 0x02, Bit 3:2	Pin A	Pin B	Pin Z
Code	Mode			
0x00	Normal	A	B	Z
0x01	Control signals for external period counters	CA	CB	CZ
0x02	<b>Calibration mode</b> <b>Offset+Phase</b> The following settings are required additionally: SELRES = 0x0D ZPOS = 0x00 HYS = 0x07 ROT = 0x00 CFGAB = 0x00 AERR = 0x00	<p>Figure 6: Offset SIN*</p>	<p>Figure 7: Offs. COS*</p>	<p>Figure 8: Phase*</p>
0x03	<b>Calibration mode</b> <b>Offset+Amplitude</b> The following settings are required additionally: SELRES = 0x0D ZPOS = 0x00 HYS = 0x07 ROT = 0x00 CFGAB = 0x00 AERR = 0x00	<p>Figure 9: Offset SIN*</p>	<p>Figure 10: Offs. COS*</p>	<p>Figure 11: Amplit.*</p>
Notes	*) Trimmed accurately when duty cycle is 50 %; Recommended trimming order (after selecting GAIN): offset, phase, amplitude ratio, offset;			

Table 17: Outputs A, B, Z

ROT	Adr 0x02, Bit 5
Code	Code direction
0x00	Ascending order, B then A
0x01	Descending order, A then B

Table 18: Code direction

CBZ	Adr 0x02, Bit 4
Code	Reset via zero
0x00	Not activated
0x01	Activated

Table 19: Reset enable for period counter

ENREDEL	Adr 0x02, Bit 7	Code	Output*	Function
0x00		0x00	immediately	An external counter displays the absolute angle following power-on.
0x01		0x01	after 5 ms	An external counter only displays changes vs. the initial power-on (conditional on standby at power-on)
Notes	*) Output delay after device configuration and internal reset (A, B, Z remains on high).			

Table 20: Output delay A, B, Z

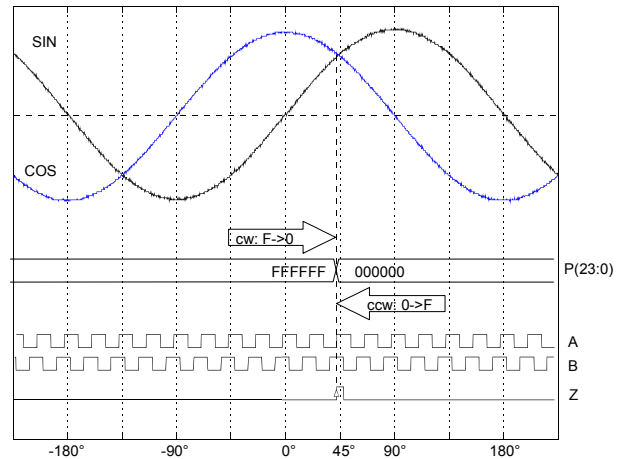

Figure 12: Period counter reset by zero signal (enabled by CBZ = 1).

Example gives a resolution of 64 (SELRES = 0x0A), a zero signal at 45° (ZPOS = 0x04, CFGAB = 0x00) and no inversion of the direction of rotation (ROT = 0x00, COS leads SIN).



ZPOS		Adr 0x01, Bit 4:0
Code	Position	
0x00	0°	
0x08	90°	
0x10	180°	
0x18	270°	
0x01	11.25° (1 x 11.25°)	
...	...	
0x1F	348.75° (31 x 11.25°)	
Notes	The zero signal is only output if released by the input pins (for instance with PZERO = 5 V, NZERO = VREF).	

Table 21: Zero signal position

CFGZ		Adr 0x02, Bit 1:0
Code	Length	
0x00	90°	
0x01	180°	
0x02.. 03	Synchronization	

Table 22: Zero signal length

CFGAB		Adr 0x03, Bit 5:4
Code	Z = 1 for	
0x00	B = 1, A = 1	
0x01	B = 0, A = 1	
0x02	B = 1, A = 0	
0x03	B = 0, A = 0	

Table 23: Zero signal logic

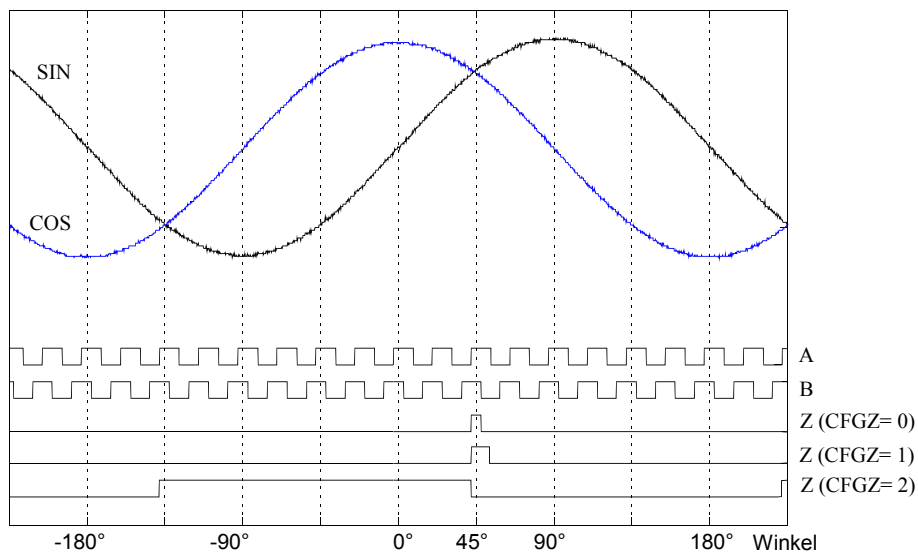

Figure 13: Incremental output signals for various zero signal lengths.

Example gives a resolution of 64 (SELRES = 0x0A), a zero signal position of 45° (ZPOS = 0x04, CFGAB = 0x00) and no inversion of the direction of rotation (ROT = 0x00, COS leads SIN).

### SIGNAL MONITORING and ERROR MESSAGES

<b>SELAMPL</b>	Adr 0x0C, Bit 2	
<b>AMPL</b>	Adr 0x0C, Bit 1:0	
<b>Max ( Sin ,  Cos ) for SELAMPL = 0</b>		
Code	Voltage threshold $V_{th}$	Output amplitude*
0x00	$0.60 \times V_{DDA}$	$1.4 V_{pp}$
0x01	$0.64 \times V_{DDA}$	$2.0 V_{pp}$
0x02	$0.68 \times V_{DDA}$	$2.6 V_{pp}$
0x03	$0.72 \times V_{DDA}$	$3.1 V_{pp}$
<b>Sin<sup>2</sup> + Cos<sup>2</sup> for SELAMPL = 1</b>		
Code	$V_{thmin} \leftrightarrow V_{thmax}$	Output amplitude*
0x04	$(0.20 \leftrightarrow 0.9) \times V_{DDA}$	$1.0 V_{pp} \leftrightarrow 4.5 V_{pp}$
0x05	$(0.30 \leftrightarrow 0.9) \times V_{DDA}$	$1.5 V_{pp} \leftrightarrow 4.5 V_{pp}$
0x06	$(0.40 \leftrightarrow 0.9) \times V_{DDA}$	$2.0 V_{pp} \leftrightarrow 4.5 V_{pp}$
0x07	$(0.50 \leftrightarrow 0.9) \times V_{DDA}$	$2.5 V_{pp} \leftrightarrow 4.5 V_{pp}$
Notes	$V_{th}$ , $V_{thmin}$ , $V_{thmax}$ are typical values; refer to Elec. Char. No. H01 cf. for maximal values. *) Entries are calculated with $V_{DDA} = 5V$ .	

Table 24: Signal amplitude monitoring

<b>AERR</b>	Adr 0x03, Bit 1
Code	Amplitude error message
0x00	disabled
0x01	enabled

Table 25: Amplitude error

<b>FERR</b>	Adr 0x03, Bit 0
Code	Excessive frequency error message
0x00	disabled
0x01	enabled
Notes	Input frequency monitoring is operational for resolutions $\geq 16$

Table 26: Frequency error

<b>Configuration error</b>	
-	Always enabled

Table 27: Configuration error

<b>Error Indication at NERR</b>	
Failure Mode	Pin signal NERR
No error	HI
Amplitude error	LO/HI = 75 % (if enabled by AERR = 1)
Frequency error	LO/HI = 50 % (if enabled by FERR = 1)
Configuration	LO
Undervoltage	LO
System error	Pulled LOW by an external error signal*.
Notes	*) This message is visible only in the BiSS stream on the nE bit; the interpolation is not stopped.

Table 28: Error indication at NERR

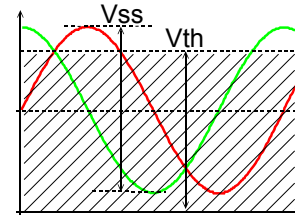

Figure 14: Signal monitoring of minimum amplitude.

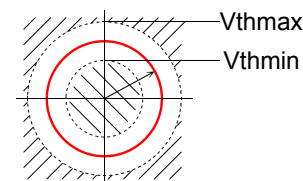

Figure 15: Sin<sup>2</sup> + Cos<sup>2</sup> signal monitoring.

<b>Error Messages</b>		
Failure Mode	Error bits E1, E0 for BiSS and SSI <b>CRC6 = 0</b>	Error bits nE, nW for BiSS and SSI <b>CRC6 = 1</b>
No error	1, 1	1, nW
Amplitude error	0, 1	0, nW
Frequency error	1, 0	0, nW
System error*	0, 0	0, nW
Warning**	—	nE, 0
Notes		
*System error	NERR pulled low by external signal	
**Warning	Automatic step-back of resolution	
Line Signal SLO	Data output is deactivated and SLO permanently high in case of: configuration phase, invalid configuration, undervoltage.	

Table 29: Error messages

To enable the diagnosis of faults, the various types of error are signaled at NERR using a PWM code as given in the key on the left.

Two error bits are provided to enable communication via the I/O interface; these bits can decode four different types of error. If NERR is held at low by an external source, such as an error message from the system, for example, this can also be verified via the I/O interface.

Error are stored until the sensor data is output via the I/O interface and then deleted. Errors at NERR are displayed for a minimum of approx. 10 ms unless they are deleted beforehand by a data output.

If an error in amplitude occurs, conversion is terminated and the incremental output signals halted. An

error in amplitude rules out the possibility of an error in frequency.

### TEST FUNCTIONS

TMODE		
Adr 0x06, Bit 3:1		
Code	Signal at Z	Description
0x00	Z	no test mode
0x01	A xor B	Output A EXOR B
0x02	ENCLK	iC-Haus device test
0x03	NLOCK	iC-Haus device test
0x04	CLK	iC-Haus device test
0x05	DIVC	iC-Haus device test
0x06	PZERO - NZERO	iC-Haus device test
0x07	TP	iC-Haus device test
Condition	CFGABZ = 0x00	

Table 30: Test mode

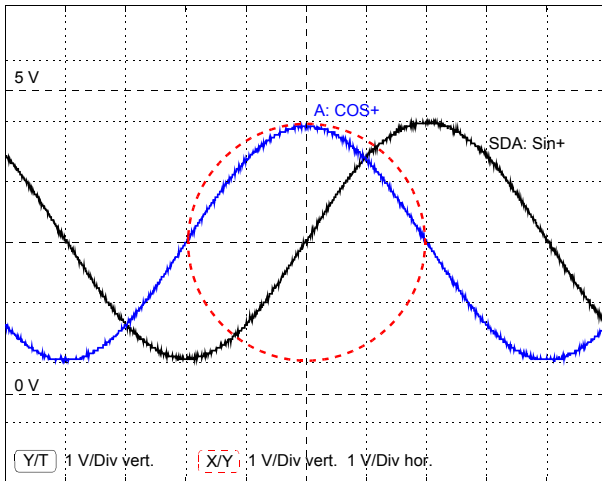

Figure 16: Calibrated signals in TMA mode.

TMA				
Adr 0x06, Bit 0				
Code	Pin A	Pin B	Pin SDA	Pin SCL
0x00	A	B	SDA	SCL
0x01	COS+	COS-	SIN+	SIN-
Notes	To permit the verification of GAIN and OFFSET settings, signals are output after the input amplifier. A converter signal of 4 Vpp is the ideal here and should not be exceeded. Pin loads above 1 MΩ are mandatory for accurate measurements. EEPROM access is not possible during mode TMA.			

Table 31: Analog test mode

The signal is set to approx. 4 Vpp using GAIN and must not be altered after calibration. Both display modes are suitable for OFFS (positive values) and RATIO adjustments; X/Y mode is preferable for PHASE. Test signals COS- (pin B) and SIN- (pin SCL) must be selected to set negative values for OFFS.

### I/O INTERFACE: BiSS C PROTOCOL

The serial I/O interface operates in the BiSS C protocol and enables sensor data output in uninterrupted cycles (data channel SCD). At the same time, parameters can be exchanged via bidirectional register communication (data channel CD).

The sensor data produced by iC-NQC contains the angle value (S) with 3 to 13 bits, the period count (P) with 0, 8, 12 or 24 bits, two error bits (E1 and E0) and 5 or 6 CRC bits (CRC).

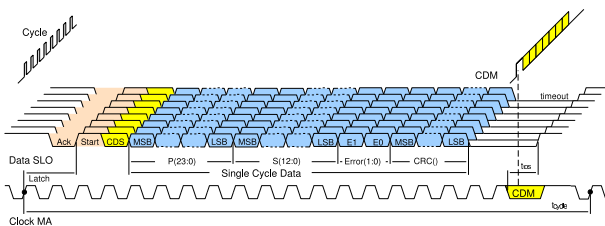

Figure 17: Example line signals (BiSS C)

Single Cycle Data Channel: SCD		
Bits	Type	Label
0...24	DATA	Period counter P(23:0): 0, 8, 12, 24 bit (multiturn position)
3...13	DATA	Angle data S(12:0): 3 bis 13 bit (singleturn position)
1	ERROR	Error bit E1 (amplitude error)
1	ERROR	Error bit E0 (frequency error)
5...6	CRC	Polynomial 0x25 $x^5 + x^2 + x^0$ (inverted bit output) - or - Polynomial 0x43 $x^6 + x^1 + x^0$ (inverted bit output)

Table 32: BiSS data channels

### Interface Parameters With BiSS C Protocol

SELSSI Adr 0x02, Bit 6		
Code	Protocol	Information
0	BiSS C	 <a href="http://www.biss-interface.com">www.biss-interface.com</a>
1	SSI	

Table 33: Protocol version

TIMO Adr 0x06, Bit 5			
Code	Clock	Timeout $t_{tos}$	fclk(MA) min*
0	46-47	approx. 20 $\mu$ s	50 kHz
1	3-4	approx. 1.5 $\mu$ s	660 kHz
TOA Addr 0x07, Bit 3			
0	see TIMO		
1	adaptive with $T_{CLK} = 42/f_{osc}$	see BiSS specification	50 kHz

Notes: A ref. clock count is equal to  $\frac{32}{f_{osc}}$  (see El. Char., A02).  
The permissible max. clock frequency is specified by E06.  
\*) A low clock frequency can reduce the permissible maximum input frequency since conversion is paused for one MA cycle from Latch onwards.

Table 34: Timeout configuration (protectable)

M2S Adr 0x00, Bit 6:5		
Code	Data Length	CRC Polynomial
0x00	-	0x25 (with CRC6 = 0)
0x01	P(7:0)	0x25 (with CRC6 = 0)
0x02	P(11:0)	0x43
0x03	P(23:0)	0x43

Table 35: Period counter output

CRC6 Adr 0x03, Bit 7		
Code	CRC Polynomial	Status Messages
0	determined by M2S	E1, E0
1	0x43	nE, nW

Table 36: CRC Polynomial and status messages

NZB Adr 0x03, Bit 6	
Code	Function
0	Zero bit
1	No zero bit

Notes: The optional zero bit is output as the final bit after the CRC.

Table 37: Zero bit

ENCDS Adr 0x00, Bit 7	
Code	Description
0x00	Data output BiSS B or SSI
0x01	Data output BiSS C

Table 38: Protocol options

M2S can be used to set the number of period counter bits sent as sensor data. The counter bits are transmitted before the angle value, with the MSB leading.

The 5-bit CRC output is based on polynomial 0x25 (100101b), with the 6-bit CRC output based on polynomial 0x43 (1000011b) automatically coming active with longer SCD data, or when preselected by CRC6. As a rule, CRC bits are sent inverted.

An additional zero bit can be output following the CRC bits. However, disabling the zero bit by NZB = 1 is recommended when the output data length does not need to comply with existing applications.

To obtain a position data output being compatible to the BiSS B protocol parameter ENCDS = 0 does switch off the CDS bit, without a replacement by a zero bit. Thus, the output data length is shorten by one bit and register communication is limited to the direction of the master to the slave. The bidirectional BiSS C register communication must be enabled by setting ENCDS = 1.

### Example of BiSS Data Output

SCD: Angle data		
Bits	Typ	Label
12	DATA	Angle data S(11:0)
2	ERROR	Error nE and warning nW
6	CRC	Polynomial 0x43
Config.	SELRES = 0x04, M2S = 0x00, CRC6 = 1, NZB = 1	

Table 39: Example format 1 for BiSS profile BP1

SCD: Angle data with 8-bit period count		
Bits	Type	Label
8	DATA	Period counter P(7:0)
13	DATA	Angle data S(12:0)
2	ERROR	Error bits E1, E0
5	CRC	Polynomial 0x25
1	Zero	Zero bit
Config.	SELRES = 0x03, M2S = 0x01, CRC6 = 0, NZB = 0	

Table 40: Example format 2

SCD: Angle data with 24-bit period count		
Bits	Type	Label
24	DATA	Period counter P(23:0)
13	DATA	Angle data S(12:0)
2	ERROR	Error bits E1, E0
6	CRC	Polynomial 0x43 (no zero bit)
Config.	SELRES = 0x03, M2S = 0x03, CRC6 = 0, NZB = 1	

Table 41: Example format 3

### Register Communication

After the BiSS C protocol slave registers are directly addressed in a reserved address area (0x40 to 0x7F). Other storage areas are addressed dynamically and in blocks. BiSS addresses 0x00 to 0x3F aim for a register bank consisting of 64 bytes, the physical storage address of which is determined by Bank Select n.

iC-NQC supports up to 16 storage banks, making it possible to use an 8-bit EEPROM to its full capacity. There is therefore also enough storage space for an ID plate (EDS) and OEM data.

Information regarding memory map and addressing via BiSS is given on page 26).

### Internal Reset Function

A write access at RAM address 0x00 (BiSS address 0x00 with Bank Select n = 0) triggers an internal reset.

Based on the current configuration in the RAM, iC-NQC restarts without reading the EEPROM. The configured interface timeout and write protect settings become active, the period counter is set to zero and any stored configuration errors are deleted. The data output via SLO and the incremental signals at A, B and Z are released. Providing no amplitude error is present, the converter again counts up from an angle value of zero to the current angle position.

### Short BiSS Timeout

For programming via the I/O interface iC-NQC has a short BiSS timeout function according to the description of the BiSS C protocol (see page 19, Table 2, El. Char. no. 6).

Regardless of register protection settings a short timeout of typically 1.8 μs can be temporarily activated by writing value 0x07 to address 0x7C (address 124d). A controller can then transmit the device configuration over a shorter period.

TOS	
Adr 0x7C, Bit 2:0	
Code	Function
000	Regular timeout (configured by TIMO)
001...111	Short timeout (equal to TIMO = 1)

Table 42: Short timeout (via BiSS device ID)

The value written to address 0x7C is also transferred to the EEPROM, provided an EEPROM has been connected up and is available.

On reading address 0x7C the byte stored in the EEPROM is output as part of the BiSS device ID. Here, high-order bits 7:3 are part of the manufacturer's ID; low-order bits 2:0 act as an indicator of the timeout options (regular or short timeout, see Table 42).

### I/O INTERFACE: SSI Protocol

iC-NQC can transmit position data in SSI protocol mode; the parameters described in the following give the necessary settings and options.

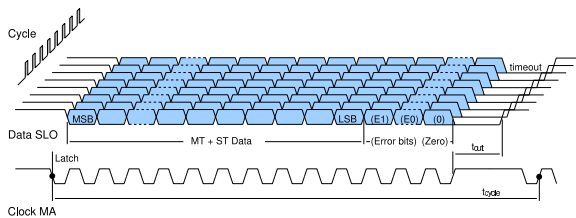

Figure 18: Example line signal (SSI)

<b>SELSSI</b> Adr 0x02, Bit 6	
Code	Protocol
0	BiSS C
1	SSI

Table 43: Protocol version

<b>TIMO</b> Adr 0x06, Bit 5		
Code	Timeout $t_{os}$	$f_{clk}(MA)_{min}^*$
0	Long: approx. 20 $\mu s$	50 kHz
1	not permitted	
<b>TOA</b> Adr 0x07, Bit 3		
0	see TIMO	
1	not permitted	
Notes	A ref. clock count is equal to $\frac{32}{f_{osc}}$ (see El. Char. A02). The permissible max. clock frequency is specified by item E06. *) A low clock frequency can reduce the permissible maximum input frequency since conversion is paused for one MA cycle from <i>Latch</i> onwards.	

Table 44: Timeout configuration for SSI

<b>M2S</b> Adr 0x00, Bit 6:5	
Code	Period counter output length
0x00	-
0x01	P(7:0)
0x02	P(11:0)
0x03	P(23:0)

Table 45: Period counter for SSI data output

<b>CRC6</b> Adr 0x03, Bit 7		
<b>NZB</b> Adr 0x03, Bit 6		
Code	Additional bits	Ring operation
0 0	E1, E0	no
0 1	none	no
1 0	nE, nW, zero bit	yes
1 1	none	yes

Table 46: Options for SSI data output

<b>GRAY</b> Adr 0x05, Bit 7	
Code	SSI data format
0	binary coded
1	gray coded
Notes	Data output starts with MSB for binary or Gray coded data.

Table 47: SSI data format

### Examples of SSI Data Output

SSI Output Formats																								
13-bit SSI																								
Res	Mode	Error	CRC	T1	T2	T3	T4... T10	T11	T12	T13	T14	T15	T16	T17	T18	T19	T20	T21	T22	T23	T24	T25		
10 bit	SSI	X	-	S9	S8	S7	S6 ... S0	E1	E0	0	Stop	Stop	Stop	Stop	Stop	Stop	Stop	Stop	Stop	Stop	Stop	Stop	Stop	
				Example									0	0	0	0	0	0	0	0	0	0	0	0
13 bit	SSI <sup>*1</sup>	-	-	S12	S11	S10	S9 ... S3	S2	S1	S0	Stop	Stop	Stop	Stop	Stop	Stop	Stop	Stop	Stop	Stop	Stop	Stop	Stop	
				Example									0	0	0	0	0	0	0	0	0	0	0	0
	SSI-R <sup>*2</sup>	-	-	S12	S11	S10	S9 ... S3	S2	S1	S0	Stop	S12	S11	S10	S9	S8	S7	S6	S5	S4	S3	S2		
Example										0														
25-bit SSI																								
13 bit	SSI	X	-	S12	S11	S10	S9 ... S3	S2	S1	S0	E1	E0	0	Stop	Stop	Stop	Stop	Stop	Stop	Stop	Stop	Stop	Stop	
				Example											0	0	0	0	0	0	0	0	0	0
8 + 13 bit <sup>*3</sup>	SSI	X	-	P7	P6	P5	P4 ... P0, S12, S11	S10	S9	S8	S7	S6	S5	S4	S3	S2	S1	S0	E1	E0	0	Stop		
				Example																				0
Configuration				Input SLI = 0, SELSSI = 1, M2S = 0x00, CRC6 = 0, NZB = 0, unless otherwise noted. *1) CRC6 = 0, NZB = 1; *2) CRC6 = 1, NZB = 1; *3) M2S = 0x01																				
Caption				SSI = SSI protocol SSI-R = SSI ring operation																				

Table 48: SSI transmission formats



### EEPROM INTERFACE

The serial EEPROM interface consists of the two pins SCL and SDA and enables read and write access to a serial EEPROM with I<sup>2</sup>C interface (with at least 128 bytes, 5 V type with a 3.3 V function; e.g. 24C01, 24C02, 24C08 and maximal 24C16).

The configuration data in the EEPROM, of addresses 0x00 to 0x0F, is secured by a CRC check value to address 0x0F. When the device is powered up, the address range from 0x00 to 0x0F is mapped onto iC-NQC's configuration RAM. The higher memory area contains BiSS C slave registers and optional memory banks available to the sensor system.

The register access to the configuration data and the memory banks 1 to 7 (intended for EDS) can be restricted by parameter RPL.

**N.B.** When writing configuration data to the EEPROM (BiSS addresses 0x10 to 0x1F) a wait time of at least 4 ms must be allowed after each register.

#### Example of CRC Calculation Routine

```

unsigned char ucDataStream = 0;
int iCRCPoly = 0x127;
unsigned char ucCRC=0;
int i = 0;

ucCRC = 0; // start value !!!
for (iReg = 0; iReg<15; iReg ++ )
{
    ucDataStream = ucGetValue(iReg);
    for (i=0; i<=7; i++) {
        if ((ucCRC & 0x80) != (ucDataStream & 0x80))
            ucCRC = (ucCRC << 1) ^ iCRCPoly;
        else
            ucCRC = (ucCRC << 1);
        ucDataStream = ucDataStream << 1;
    }
}
    
```

CRC_E2P Adr 0x0F, Bit 7:0	
Code	Description
0x00	Check value formed by CRC polynomial 0x127
...	
0xFF	

Table 49: Check value for EEPROM data

Register Configuration		
BiSS Adr hex	BiSS Adr decimal	Contents
0x00...0F	0...15	Config. Data RAM (16 bytes)
0x10...1F	16...31	Config. Data EEPROM (16 bytes)
0x20...3F	32...63	Unused memory area (32 bytes)
BiSS C Slave-Registers (direct addresses):		
0x40	64	Bank Select (1 byte)
0x41	65	EDS Bank (1 byte)
0x42...43	66...67	Profile ID (2 bytes)
0x44...47	68...71	Serial No. (4 bytes)
0x48...77	72...119	Slave Registers (48 bytes)
Device ID (6 bytes):		
0x78	120	4E (default)
0x79	121	51 (default)
0x7A	122	43 (default)
0x7B	123	31 (default)
0x7C	124	Bit 7:3: Adr 0x00, Bit 2:0: TOS
0x7D	125	00 (default)
Manufacturer's ID (2 bytes):		
0x7E	126	69 (default)
0x7F	127	43 (default)

Table 50: Register overview

RPL Adr 0x03, Bit 3				
Code	Bank 0 Config. Dat.	0x40..7F BiSS ID	Bank 1..7 EDS	Bank 8..15 User Data
0x0	read / write	read / write	read / write	read / write
0x1	-	read*	read	read / write
Notes	*) Exception: write to 0x40 and 0x7C is always possible.			

Table 51: Register protection settings

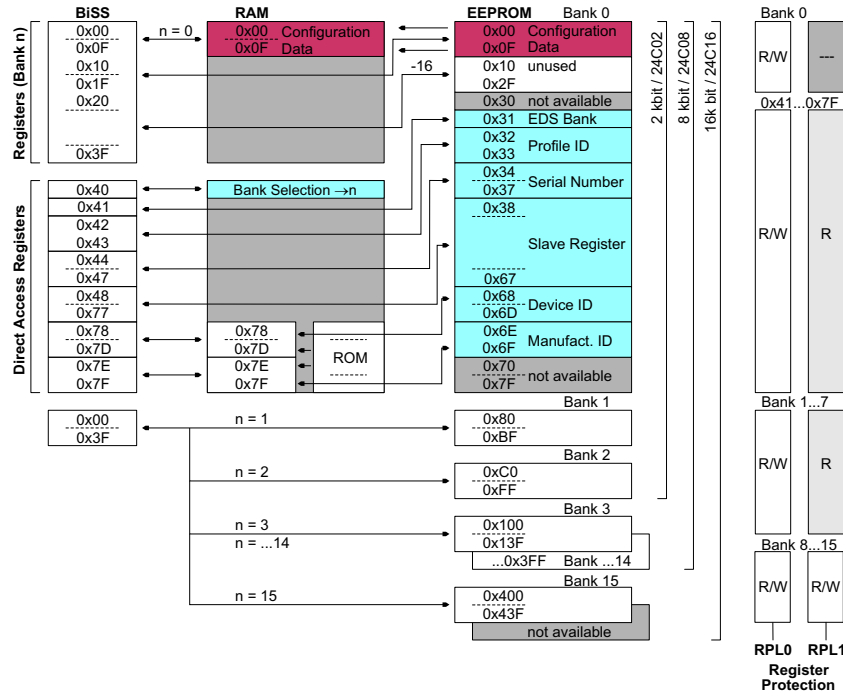

Figure 19: Registers and addressing

### STARTUP BEHAVIOR

#### Startup With A Configured EEPROM

After the supply has been turned on (power-on reset), iC-NQC reads the configuration data from the EEPROM. During this phase it actively keeps error pin NERR at a low signal (open drain output), and data output SLO and the incremental signals at A, B and Z at a high signal.

After a successful CRC the data output to SLO and to the incremental A, B, and Z outputs is released and the error indication at pin NERR reset; an external pull-up resistor at pin NERR can supply a high signal. iC-NQC then switches to normal operation and determines the current angle position, providing that a sensor is connected up to it and there is no amplitude error (or this is deactivated).

Should the CRC prove unsuccessful due to a data error (disrupted transmission, no EEPROM or the EEPROM is not programmed), the configuration phase is automatically repeated. After a third failed attempt, the procedure is aborted and error pin NERR displays a permanent low; data output SLO and the incremental signals at A, B and Z remain at a high signal.

#### Startup Without An EEPROM

The configuration RAM contains random values after startup; iC-NQC does not have a default configuration. Error pin NERR shows a low signal (open drain output); data output SLO and the incremental signals at A, B and Z indicate a high signal.

To reduce the device configuration time, a short timeout of 3  $\mu$ s maximum (cf. TIMO = 1 and TOA = 0) can be temporarily activated by writing value 0x07 to address 0x7C (address 124d).

When operated without an EEPROM, iC-NQC does not respond to higher addresses - with the exception of the BiSS addresses reserved for manufacturer and device IDs (0x78 to 0x7F). This address area supplies the chip version from the ROM.

#### Initialization After Configuration Failure

So that it is always possible to talk to iC-NQC via the I/O interface, iC-NQC first ignores the register values of TIMO, TOA, RPL and TMA. Instead, iC-NQC applies the longest timeout (cf. TIMO = 0 and TOA = 0), ignores safety settings (cf. RPL = 0x0) and evaluates the BiSS register communication (CDM bit from the CD data channel).

During this phase regular bidirectional BiSS register communication is not yet possible, as data output SLO is permanently kept at high. Writing the configuration to RAM addresses 0x01 to 0x0C and to address 0x00 must be executed without evaluating a reply. Data input SLI is ignored; iC-NQC always uses slave ID 0.

Each cycle transmits a single bit only and can be reduced to four clocks plus the timeout (CDM). The fol-

lowing figures each show a single cycle with CDM = 0 and CDM = 1. A wide range of 100 ns to 12.5 μs is permissible for clock period T(MA); the timeout must last at least 30 μs.

A complete write cycle requires 14 cycles at CDM = 0 and a sequence of 32 cycles calculated according to BiSS-C register communication.

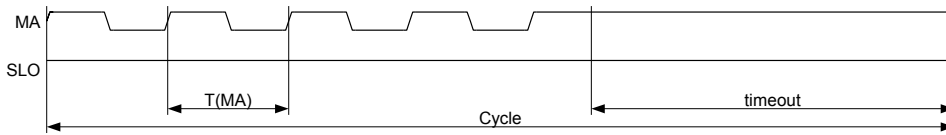

Figure 20: BiSS cycle at CDM = 0

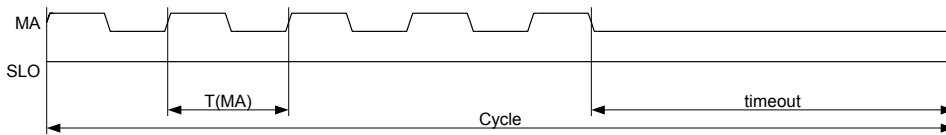

Figure 21: BiSS cycle at CDM = 1

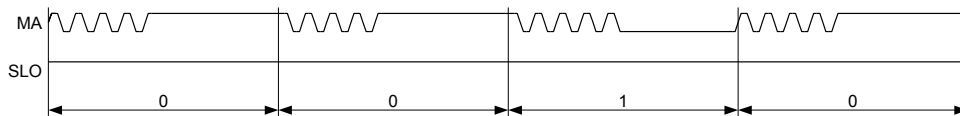

Figure 22: BiSS cycle extract for a CDM sequence of '0010'.

Ahead of a write access to address zero finishing the initialization phase and setting the BiSS interface to normal operation, at least the following register bits need to be reset: SELSSI at address 0x02, RPL at address 0x03, and TMA and TIMO at address 0x06.

The following sequence gives an example of programming addresses 0x02, 0x03 and 0x06 to zero and subsequently executing a reset by programming address 0x00 with a value of 0x8D (141d).

```
"0000000000000000"
"11000000001000000110000000011110"
"0000000000000000"
"11000000001100110110000000011110"
"0000000000000000"
"11000000011011000110000000011110"
"0000000000000000"
"11000000000001100111000110101010"
```

**Notes:** Data output SLO is only operational following initialization. The controller needs to execute the described initialization without any feedback (sending CDM bits without evaluating CDS bits).

**N.B.:** CDM bits are inverted on the line; when CDM = 1 the timeout is at low.

**Programming tip:** After writing a byte to the EEPROM the same byte should be read back. When doing so, iC-NQC does not output the start bit if the EEPROM is busy with its internal write procedure and so denies I2C access. Several read attempts may be required if the I2C interface is still blocked causing iC-NQC to refuse the read access.

When writing to the EEPROM without reading the byte back, a wait time of at least 4 ms must be allowed after each register.

### APPLICATION NOTES

#### Principle Input Circuits

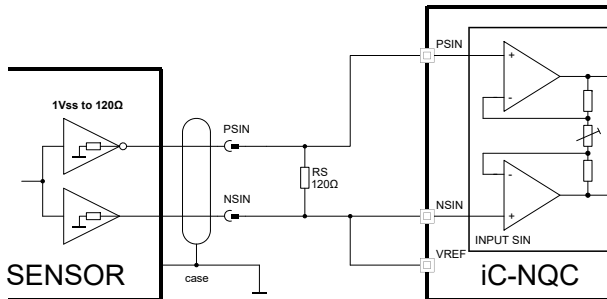

Figure 23: Input circuit for voltage signals of 1 Vpp with no ground reference. When ground is not separated the connection NSIN to VREF must be omitted.

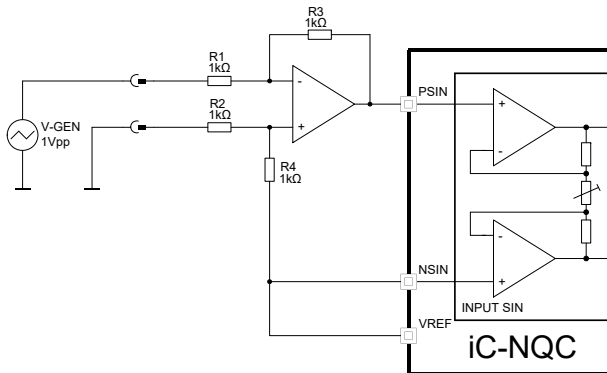

Figure 25: Input circuit for non-symmetrical voltage or current source signals with ground reference (adaptation via resistors R3, R4).

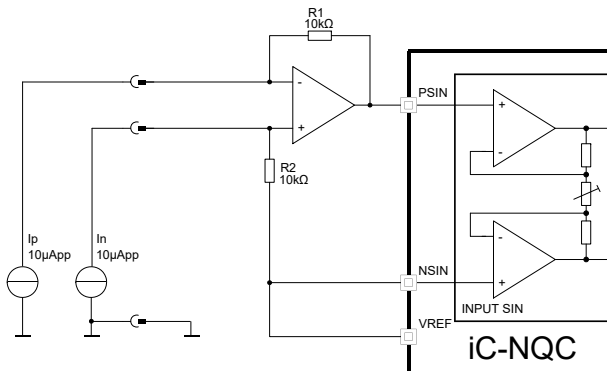

Figure 27: Input circuit for complementary low-side current source outputs, such as for opto encoder iC-WG.

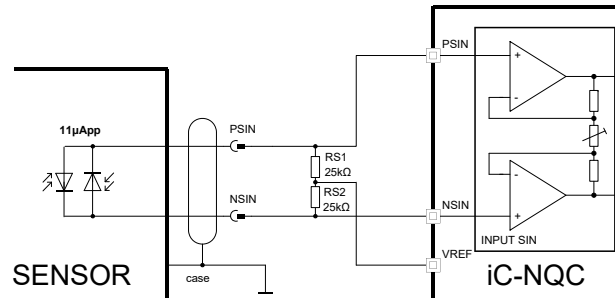

Figure 24: Input circuit for current signals of 11 μA with no ground reference. Offset calibration is not possible with this circuit.

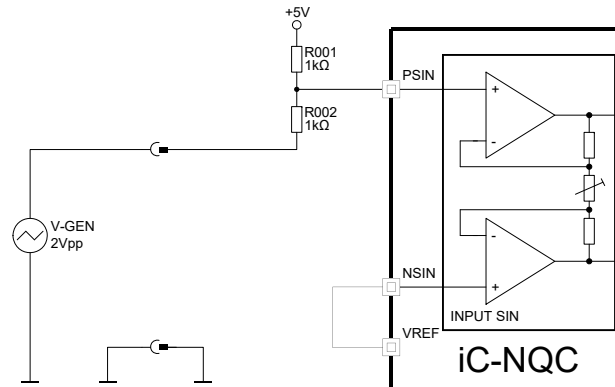

Figure 26: Simplified input wiring for non-symmetrical voltage signals with ground reference.

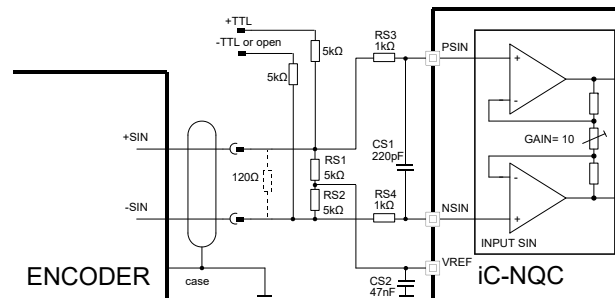

Figure 28: Combined input circuit for 11 μA, 1 Vpp (with 120 Ω termination) or TTL encoder signals. RS3/4 and CS1 serve as protection against ESD and transients.

### Input Circuit for Sine Encoders (1 Vpp)

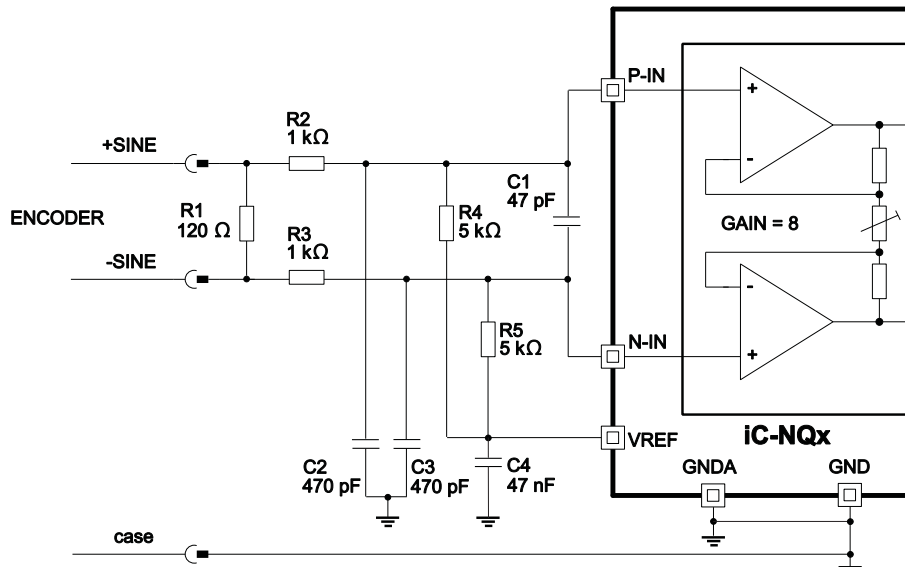

Figure 29: Input circuit for sine encoders (0.8 Vpp to 1.2 Vpp) with 120 Ω termination and low-pass filtering. R2/R3 serve as protection against ESD and transients, R4/R5 reduce the input signal to suit an input gain of 8.

### Basic Circuit for MR Sensors

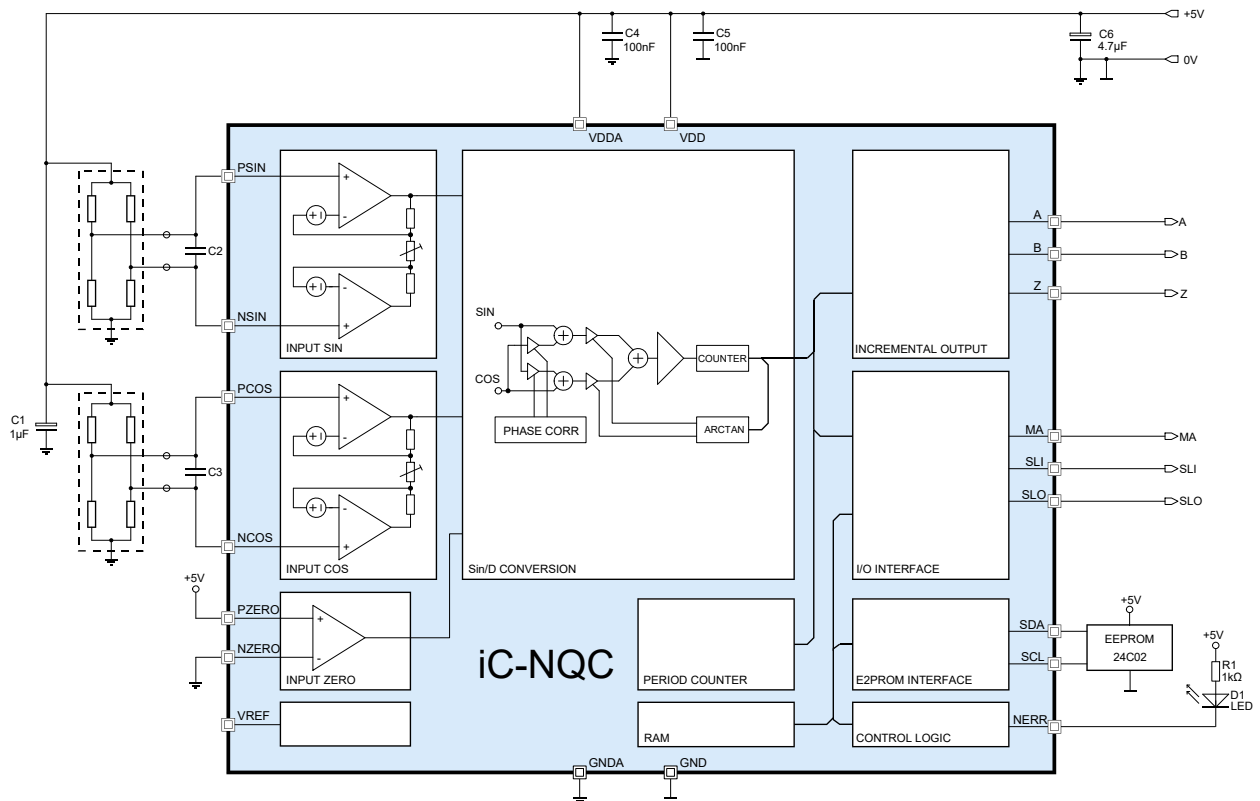

Figure 30: Basic circuit for the evaluation of MR bridge sensors.

### EVALUATION BOARD

iC-NQC comes with a demo board for test purposes.  
Instructions are available separately.

### DESIGN REVIEW: Function Notes

iC-NQC 2		
No.	Function, Parameter/Code	Description and Application Notes
		Please refer to datasheet release B1.

Table 52: Notes on chip functions regarding iC-NQC chip revision 2.

iC-NQC 3		
No.	Function, Parameter/Code	Description and Application Notes
1	<b>GRAY</b>	For Gray-coded data output clock cycles must be fully completed. An earlier termination results in invalid data for the following read out cycle.
2	<b>Startup</b>	An invalid CRC keeps only SLO permanently on high, the incremental output to A, B and Z is not blocked.

Table 53: Notes on chip functions regarding iC-NQC chip revision 3.

iC-NQC 5		
No.	Function, Parameter/Code	Description and Application Notes
1	<b>GRAY</b>	Gray-coded data output can be terminated at any time.
2	<b>Startup</b>	An invalid CRC keeps SLO and A, B and Z permanently on high (until an internal reset).
3	<b>Period counting</b>	Following power-on and after an internal reset the period counter is initialized with a value of zero (as all former chip releases). If an input angle of exactly 0° is applied and a movement towards 270° is following, the period counter counts to the value -1 (former chip releases maintain the value of zero).
4	<b>Serial Data Output,</b> power-up behavior with FCTR > 0x4702	Serial data can be raw initially if FCTR enables automatic step-down of resolution and if the input signals are absolutely stable during power up. Settling to the input angle at full resolution is obtained as soon as the inputs change.  Note: The warning bit (use CRC6 = 1) indicates a reduced resolution (by nW = 0) during initial settling and tracking of high input frequencies.

Table 54: Notes on chip functions regarding iC-NQC chip revision 5.

**REVISION HISTORY**

Rel.	Rel. Date*	Chapter	Modification	Page
E1	2020-03-02	PACKAGING INFORMATION	Package dimensions added	4
		ELECTRICAL CHARACTERISTICS	Item 108: added for full-scale signal Item A02, fosc at 5 V: adaption of limits Items D06, D07 added as new items Items E07, E08 moved to Operating Requirements	7
		OPERATING REQUIREMENTS: I/O Interface	Section updated, new figures added	10
		CONVERTER FUNCTIONS	Table 13: Note added on hysteresis	13
		SIGNAL MONITORING and ERROR MESSAGES	Table 28: Note added on system error	18
		DESIGN REVIEW: Function Notes	Table 54: item 4 added	30

iC-Haus expressly reserves the right to change its products and/or specifications. A Datasheet Update Notification (DUN) gives details as to any amendments and additions made to the relevant current specifications on our internet website [www.ichaus.com/DUN](http://www.ichaus.com/DUN) and is automatically generated and shall be sent to registered users by email.

Copying – even as an excerpt – is only permitted with iC-Haus' approval in writing and precise reference to source.

The data specified is intended solely for the purpose of product description and shall represent the usual quality of the product. In case the specifications contain obvious mistakes e.g. in writing or calculation, iC-Haus reserves the right to correct the specification and no liability arises insofar that the specification was from a third party view obviously not reliable. There shall be no claims based on defects as to quality in cases of insignificant deviations from the specifications or in case of only minor impairment of usability.

No representations or warranties, either expressed or implied, of merchantability, fitness for a particular purpose or of any other nature are made hereunder with respect to information/specification or the products to which information refers and no guarantee with respect to compliance to the intended use is given. In particular, this also applies to the stated possible applications or areas of applications of the product.

iC-Haus products are not designed for and must not be used in connection with any applications where the failure of such products would reasonably be expected to result in significant personal injury or death (*Safety-Critical Applications*) without iC-Haus' specific written consent. Safety-Critical Applications include, without limitation, life support devices and systems. iC-Haus products are not designed nor intended for use in military or aerospace applications or environments or in automotive applications unless specifically designated for such use by iC-Haus.

iC-Haus conveys no patent, copyright, mask work right or other trade mark right to this product. iC-Haus assumes no liability for any patent and/or other trade mark rights of a third party resulting from processing or handling of the product and/or any other use of the product.

Software and its documentation is provided by iC-Haus GmbH or contributors "AS IS" and is subject to the ZVEI General Conditions for the Supply of Products and Services with iC-Haus amendments and the ZVEI Software clause with iC-Haus amendments ([www.ichaus.com/EULA](http://www.ichaus.com/EULA)).

\* Release Date format: YYYY-MM-DD

**ORDERING INFORMATION**

Type	Package	Options	Order Designation
iC-NQC	TSSOP20 4.4 mm RoHS compliant	Temperature range -40 °C to +125 °C	iC-NQC TSSOP20 iC-NQC TSSOP20 ET -40/125
Evaluation Board			iC-NQC EVAL NQ6D

Please send your purchase orders to our order handling team:

**Fax: +49 (0) 61 35 - 92 92 - 692**

**E-Mail: [dispo@ichaus.com](mailto:dispo@ichaus.com)**

For technical support, information about prices and terms of delivery please contact:

**iC-Haus GmbH  
Am Kuemmerling 18  
D-55294 Bodenheim  
GERMANY**

**Tel.: +49 (0) 61 35 - 92 92 - 0  
Fax: +49 (0) 61 35 - 92 92 - 192  
Web: <http://www.ichaus.com>  
E-Mail: [sales@ichaus.com](mailto:sales@ichaus.com)**

**Appointed local distributors: [http://www.ichaus.com/sales\\_partners](http://www.ichaus.com/sales_partners)**