

MULTIPIN RACK AND PANEL CONNECTORS



NSX - BPX series
Arinc 600

RADIALL 
The next conneXion

COMPANY PROFILE

Radiall was founded in 1952 as a family owned company making coaxial plugs for the television industry. Today, Radiall is an international and global manufacturer of interconnect components including RF coaxial connectors and cable assemblies, antennas, fiber optic and microwave components, and multipin connectors. Radiall serves the Aerospace, Automotive, Defense, Industrial, Medical, Space, and Telecommunication industries.

QSE (Quality Safety Environment) POLICY

Radiall maintains a quality management system that is highly recognized by its customers because it conforms to most international standards, including those for environmental protection.



Since 1994, all Radiall sites are ISO9001 certified. As a result of Radiall's continuous improvement efforts, some dedicated activities are certified to either AS9100, or TS 16949 or ISO14001. Certain product lines are MIL ESA/SCC Qualified products.

Radiall also complies with other industry directives such as RoHS for hazardous substance restrictions and EuP for environmentally friendly designs for energy-consuming products.



A WORLDWIDE ENGINEERING & MANUFACTURING CAPABILITY



With expertise centers and manufacturing locations in 3 continents and 12 industrial sites, Radiall offers its customers the proximity needed to provide the best quality, service and delivery performance.

Our facilities feature state of the art equipment for the many technologies involved in the design, manufacturing and assembly of interconnect solutions. Manufacturing plants based in low cost countries give Radiall the opportunity to offer quality at competitive prices.

Technical information and sales contacts are available at : www.radiall.com

Introduction	4	NSX F/G	
NSX - ARINC		How to order	89
Description	5	Front removable contacts	90-93
Characteristics	6	NSX - SINGLE SHELL	
Shell dimensions	7 - 18	Description	94
Shell polarization	19 - 21	How to order	95
Modification code	22 - 24	Installation	96-97
Signal, power and ground contacts	25 - 27	Shell dimensions	98-99
Chromel contacts	28	Tables	100
Alumel contacts	29	Panel cut out	101
Coaxial contacts	30-40	NSX EMI/RFI	
Concentric twinax contacts	40 - 41	Description	102
Quadrax contacts	42	Technical characteristics	102
Wiring instructions	43-60	Dimensions	103 - 106
Tools	61	NSX T CAS	
Insertion/extraction tools	62	Description	107
Sealing plugs	63-64	How to order	108-109
Dummy inserts	65	Coaxial contacts	109-110
Dust caps	66-67	Wave guide	111
Cavity reducers	68	BPX	
Sealing boots	69	Description	112
Alignment boot	69	Characteristics	112
Panel cut out	70-71	How to order	113
Mass	72	Insert combination code	114
NSX E/N/H/C		Contacts	114
How to order	73	Sealing boot	114
Insert combination codes	74-77	Dust caps	115-117
Contact arrangements	78-87	Dimensions	118-123
Signal, power and ground contacts	87	Panel cut out	124-125
Coaxial and triaxial contacts	87	Index of RADIALL P/N	126-127
Rear removable contacts	88		

MULTICONTACT CONNECTORS NSX-ARINC 600 / BPX

NSX series (defined by ARINC 600 specification) and **BPX** series (defined by Boeing S280W551 specification) are multipin rack and panel connectors used to connect high performance aeronautical equipments.

These two series manufactured by **RADIALL** show the following characteristics :

- High contact density (up to 800 contacts).
- Numerous contact arrangements.
- Numerous shell polarization possibilities which give maximum security when mating the equipment in the rack.
- Low mating forces.
- Separation of power and signal contacts.
- EMI/RFI shielding provided by shell to shell conductivity.
- Wide range of contact types and sizes.

RADIALL has a lot of customers approval for her NSX series. Among them are the airframe manufacturers and equipments manufacturers.

MULTICONTACT CONNECTORS NSX-ARINC 600

RADIALL NSX series offers **the following versions** :

Connectors for **rear removable** contacts :

- **NSX N** : plug and receptacle connectors. Non environmental version, inserts without grommet and compound, plugs without groove and O-ring.
- **NSX C** : plug and receptacle connectors. Non environmental version, inserts with grommet but without compound, plugs without groove and O-ring.
- **NSX E** : plug and receptacle connectors. Environmental version, inserts with grommet and compound, plugs with groove and O-ring.
- **NSX H** : plug connectors only. Environmental version, inserts with grommet and compound, plugs without groove and O-ring.

Connectors for **front removable** contacts :

- **NSX F** : receptacle connectors only. Front release, front removable signal contacts only. Non environmental version, inserts without grommet and compound.
- **NSX G** : identical to NSX F but with front release front removable signal, power, coax, triax and quadrax contacts.

EMI/RFI shielded connectors : shell to shell conductivity.

RADIALL offers a wide range of inserts which can be fitted with signal contacts only or with signal, power, coaxial, triaxial, and quadrax contacts.

The range of contacts offered allows **RADIALL** to satisfy any of its customer needs :

Sealing boots, sealing plugs, dust caps conductive or non conductive and cavity reducers.

Standard tools : crimping tools, positioners, dies, insertion/extraction tools.

Signal contact : size 22-crimp, solder tail and wire wrap post.

Power contact : size 20-16-12-8-crimp and solder tail (except size 8).

Coaxial contact : size 16-8-5-1-crimp and solder tail.

Concentric twinax contact : size 8-crimp and solder tail.

Fiber optic contact : size 16 and 12.

Thermocouple contact : size 22 and 20-crimp.

Quadrax contact : size 8 crimp and solder tail.

Items in this catalog are covered by French and foreign Patents and/or Patents pending.

SHELL

RADIALL NSX series offers three metallic shell sizes fitted with polarization hardware offering 216 polarizing possibilities.

Plug shell is fitted with inserts for signal (size 22) pin contacts, coax, triax and quadrax power socket contacts.

Receptacle shell is fitted with inserts for signal socket contacts, coax, triax and quadrax power pin contacts.

The shell flange has bosses on each side and at both ends to locate the connector on the mounting panel. Shell size 1 can be mounted on a front panel or laterally by using the 3 threaded inserts on both side of the connector. The O-ring on the plug shell (environmental) allows the connector pair to be sealed once mated.

INSERTS

Environmental inserts have a wire sealing grommet on the rear face and compound between insert and shell.

Inserts are replaceable without having an effect on connector intermateability (shell + insert from the same supplier).

The different kind of inserts available are :

- Insert for rear release rear removable contacts (colored blue on the terminating face).
- Insert for front release front removable contacts (colored red on their mating face).
- Insert for front release rear removable contacts (colored yellow on their mating face).

CONTACTS

The contacts are removable from the insert using an appropriate extraction tool. Tools are available for front and rear release inserts.

Inserts use a metal contact retention system (clips) which assures the contact retention requirements of ARINC 600 to be met. The retention system allows contacts to be removed from the insert using an extraction tool.

Signal and power contacts are low insertion force contacts.

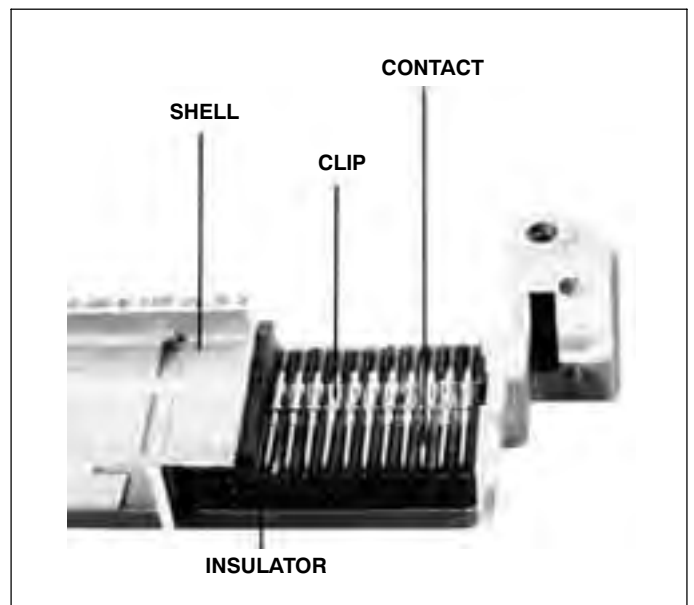

TECHNICAL CHARACTERISTICS

DESCRIPTION	MATERIAL	PLATING
Shell	Aluminum alloy	Chromatation or nickel
Inserts	Thermosetting resin or thermoplastic	/
Metallic inserts	Aluminum alloy	Nickel
O-ring & grommet	Fluorosilicone	/
Contacts	Copper alloy	Gold over nickel
Retention clip	Copper alloy	/
Insert retention plate	Aluminum alloy	Blue anodized or nickel
Polarization posts and keys retention plate	Aluminum alloy	Chromatation or nickel
Screws washers and clinch-nuts	Stainless steel	/
	Steel	Cadmium yellow chromate
Polarization posts and keys	Zinc alloy	Nickel

ELECTRICAL CHARACTERISTICS

CONTACT SIZE	WIRE				MAX CURRENT (A)
	AWG	CROSS SECTION (mm ²)	OUTSIDE DIA. inches (mm)		
			min.	max.	
22	22	0.38	.026 (0.66)	.055 (1.4)	5
	24	0.21			3
	26	0.14			2
20	20	0.60	.040 (1)	.071 (1.8)	7.5
	22	0.38			5
	24	0.21			3
16	16	1.34	.066 (1.7)	.102 (2.6)	13
	18	0.93			10
	20	0.60			7.5
12	12	3.18	.094 (2.4)	.134 (3.4)	23
	14	1.91			17
	16	1.34			13
8	8	9	.183 (4.65)	.255 (6.48)	46
	10	5			33

MECHANICAL AND ENVIRONMENTAL

- Temperature range : -65°C/+125°C.
- Temperature life : 1000 hours at 125°C.
- Salt spray : MIL-STD-1344 method 1001.1 test condition B (48 hours).
- Moisture resistance : MIL-STD-1344 method 1002.1 test condition II (10 times 24 hours).
- Sealing : environment resistant to running water (environmental version only).
- Fluid resistance : resistance to MIL-STD-1344 method 1016 (fluids a, e, i).
- Durability : 500 mating and unmating cycles.
- Random vibration : conforming to MIL-STD-1344 method 2005.1 test condition 5 letter E. (16,4g from 50 to 2000Hz, 8 hours per direction).
- Shock : 50g 11 ms half sine.MIL-STD-1344 method 2004.1 3 impacts per direction.
- Mating force : connector size 1 ↓ 27 pounds (120 N) max,
connector size 2 ↓ 60 pounds (267 N) max,
connector size 3 ↓ 105 pounds (467 N) max.

- Contact retention force

CONTACT SIZE	22	20	16	12	8	coax triax quadrx
Retention force min (ounces)	12	20	25	30	25	25

COAX CONTACTS ELECTRICAL CHARACTERISTICS

- Nominal impedance : 50I .
- DWV : 1500 VAC - IR at 25°C = 5000 MI .
- V.S.W.R. : Size 5 ↓ 1.3 from DC to 1500 MHz and insertion loss = 0.3 dB,
Size 1 ↓ 1.3 from DC to 5000 MHz.

NSX- ARINC 600

NON ENVIRONMENTAL SIZE 1 PLUG SHELL DIMENSIONS

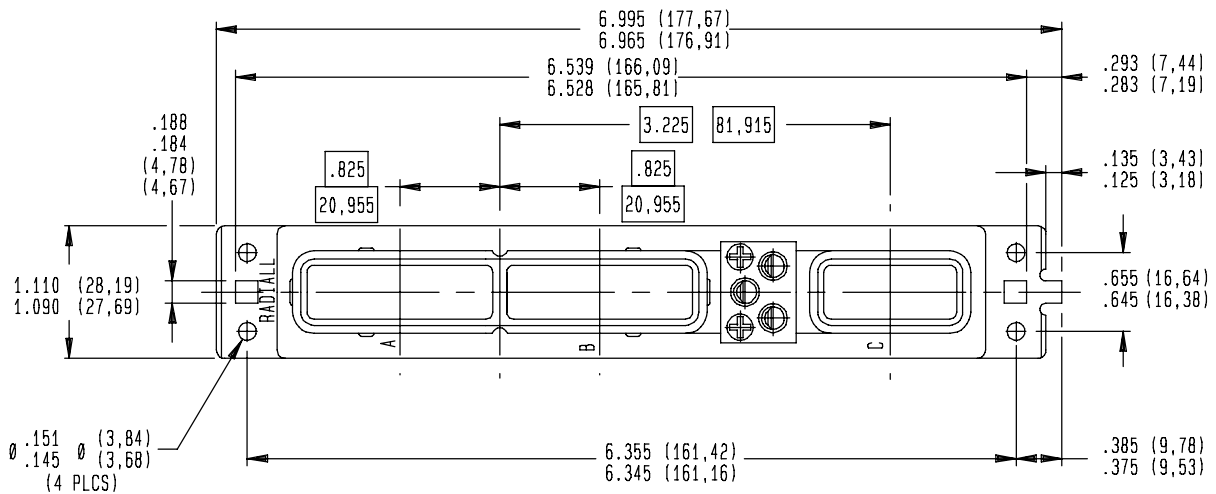
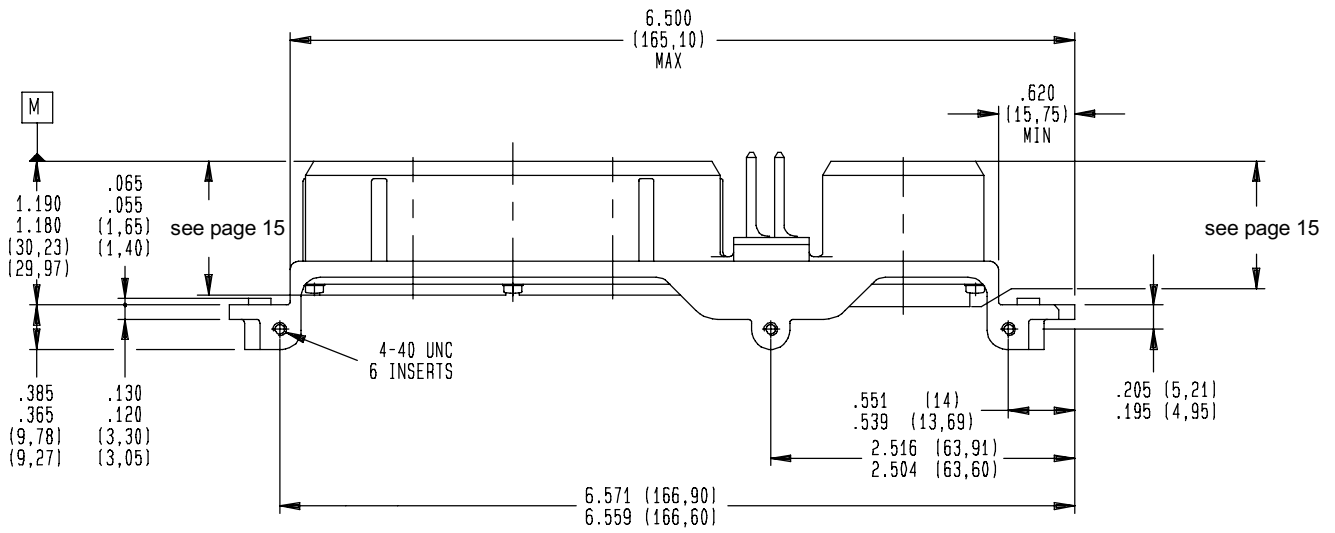
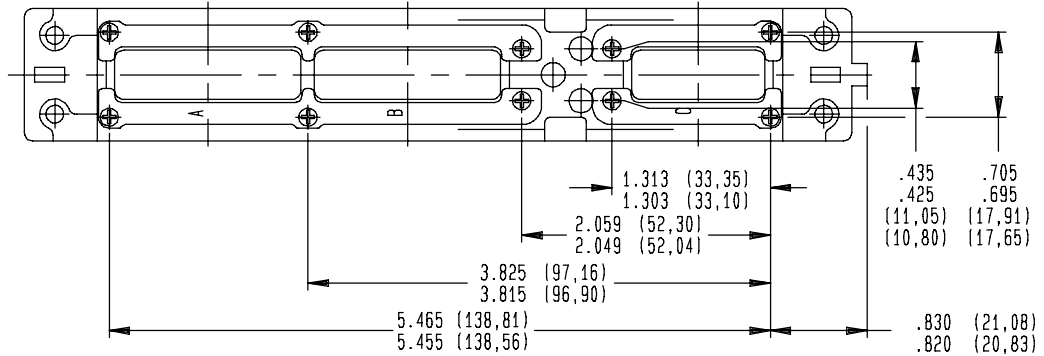

NSX- ARINC 600

NON ENVIRONMENTAL SIZE 1 RECEPTACLE SHELL DIMENSIONS

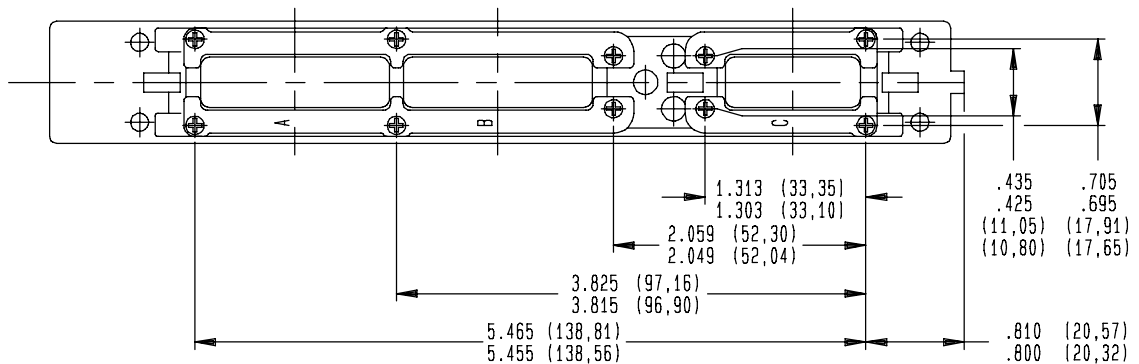
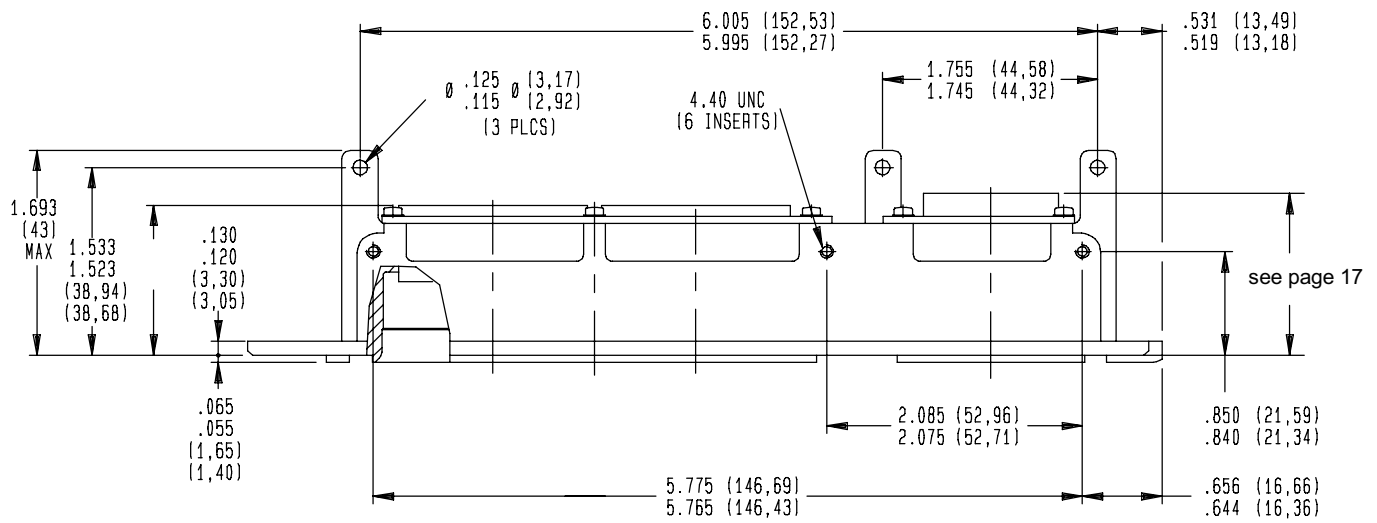
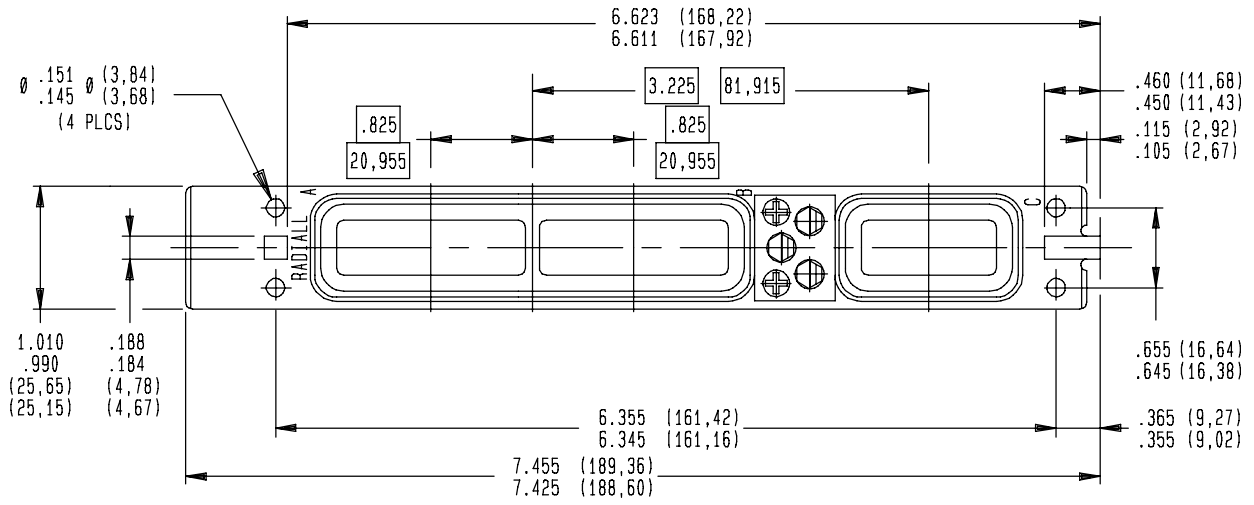

NSX- ARINC 600

NON ENVIRONMENTAL SIZE 2 PLUG SHELL DIMENSIONS

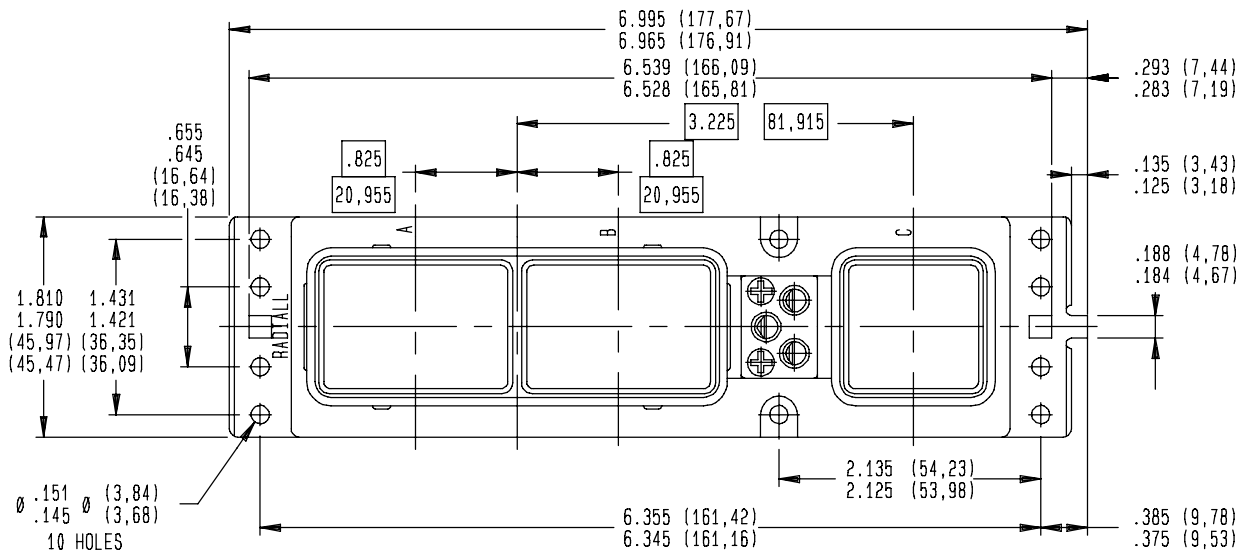
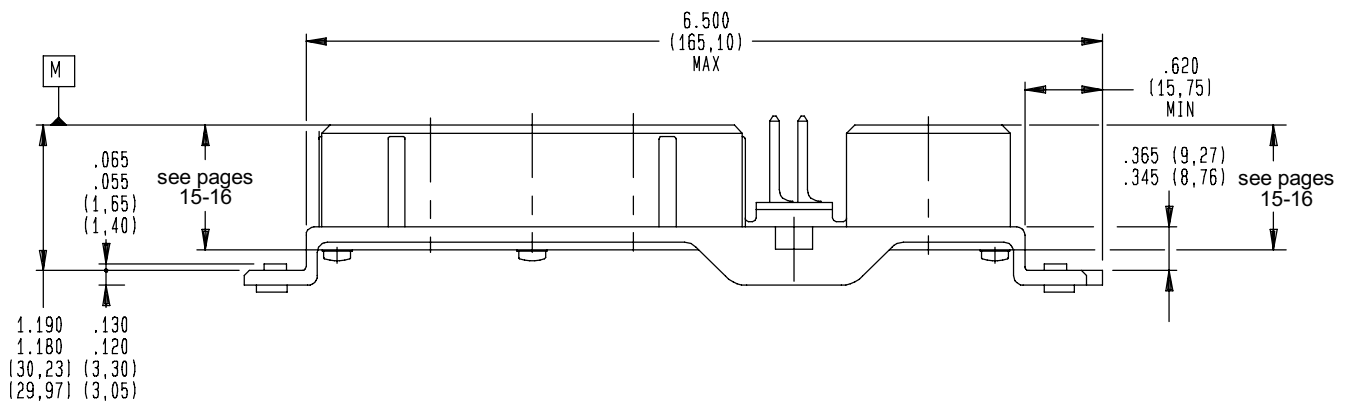
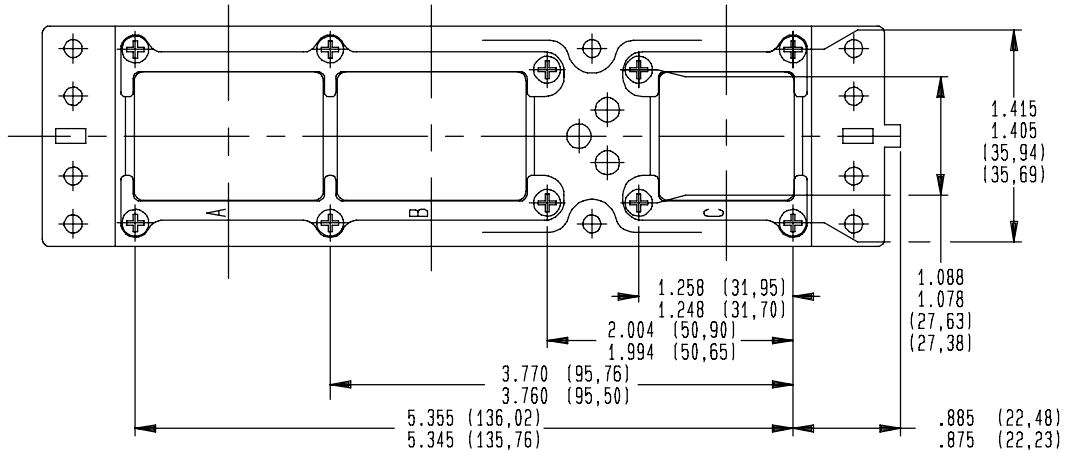

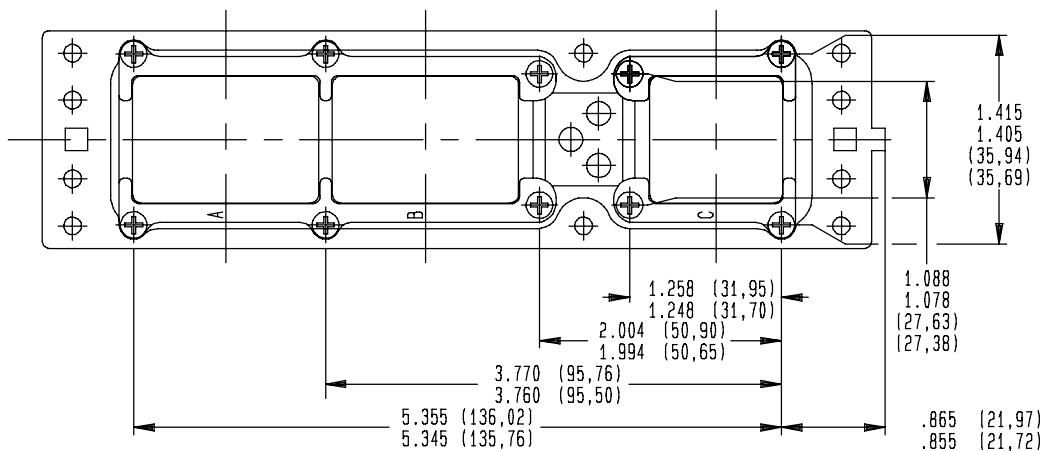
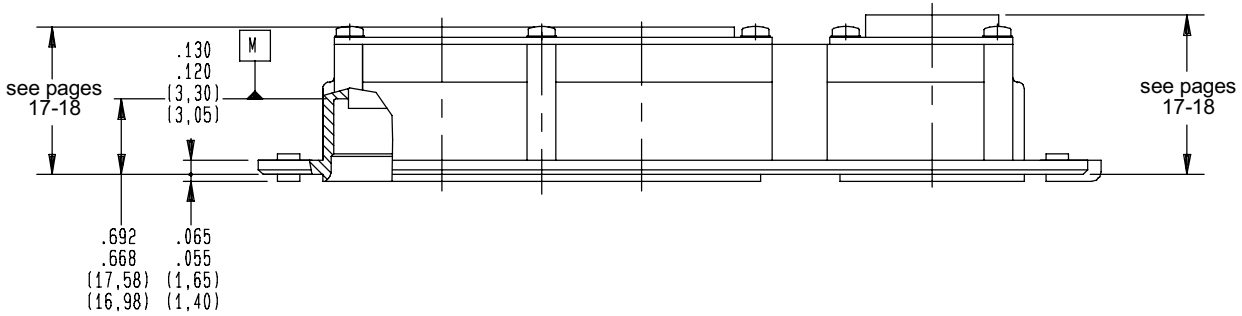
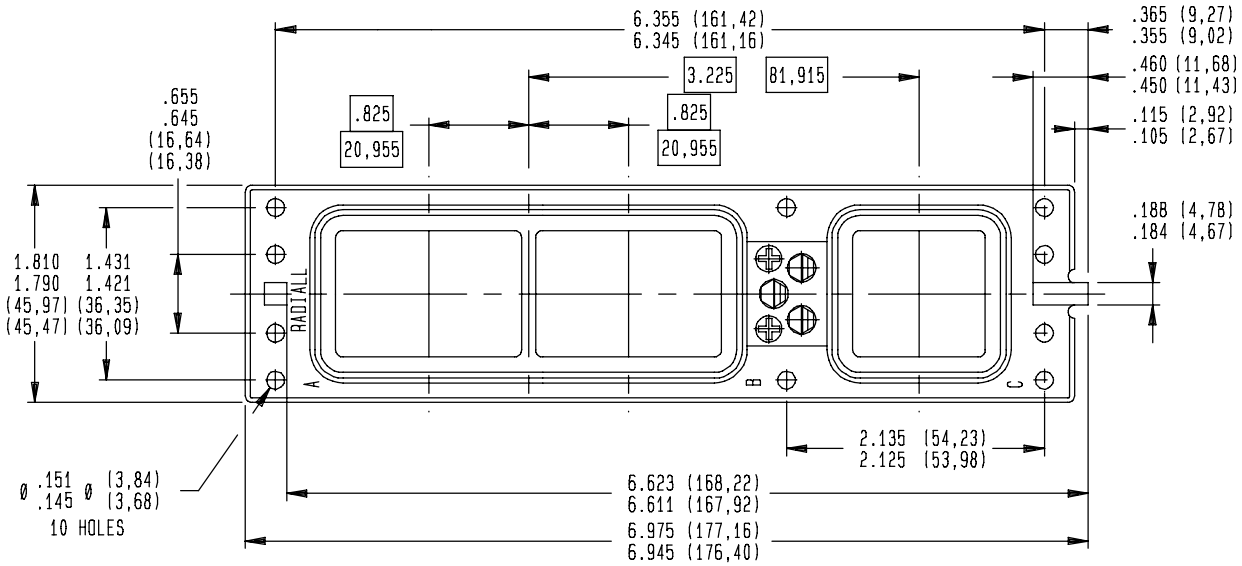

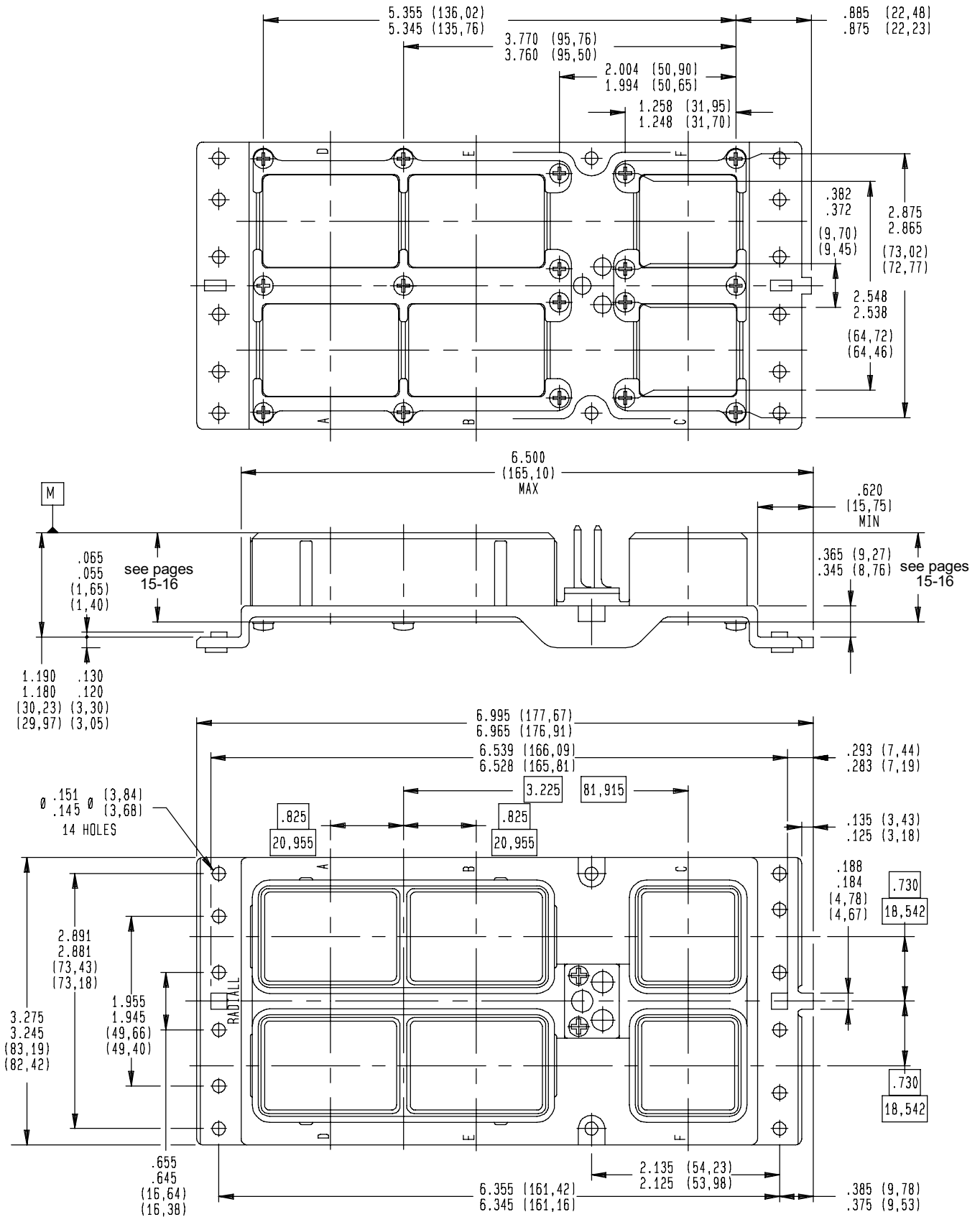

NSX- ARINC 600

NON ENVIRONMENTAL SIZE 3 RECEPTACLE SHELL DIMENSIONS

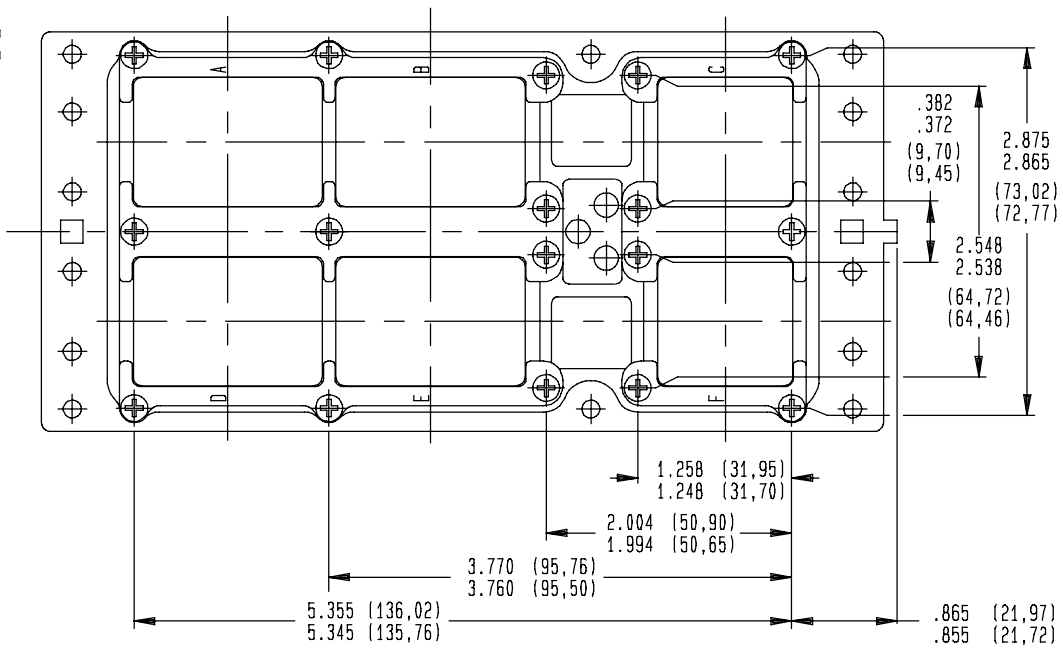
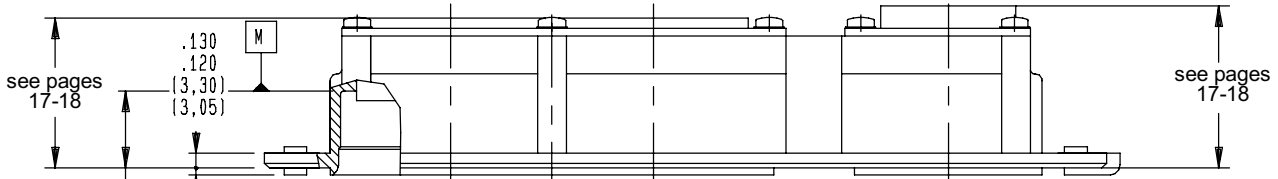
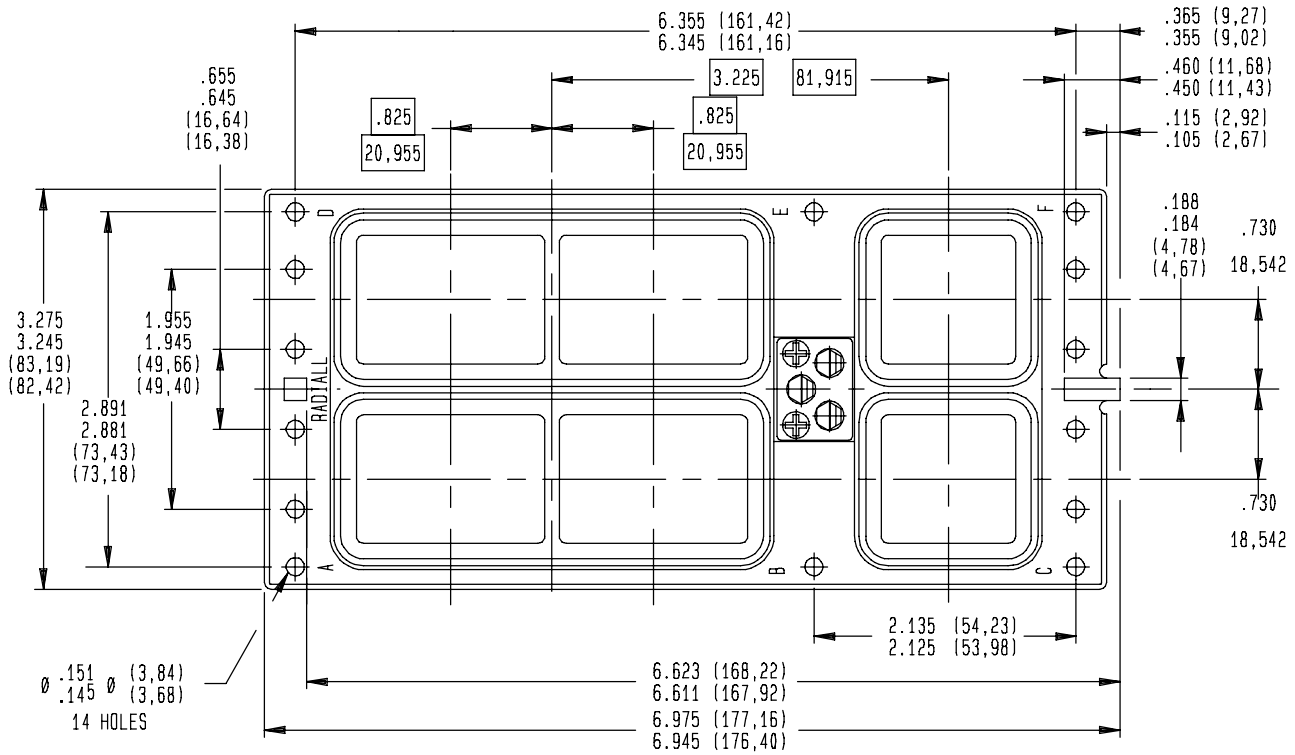

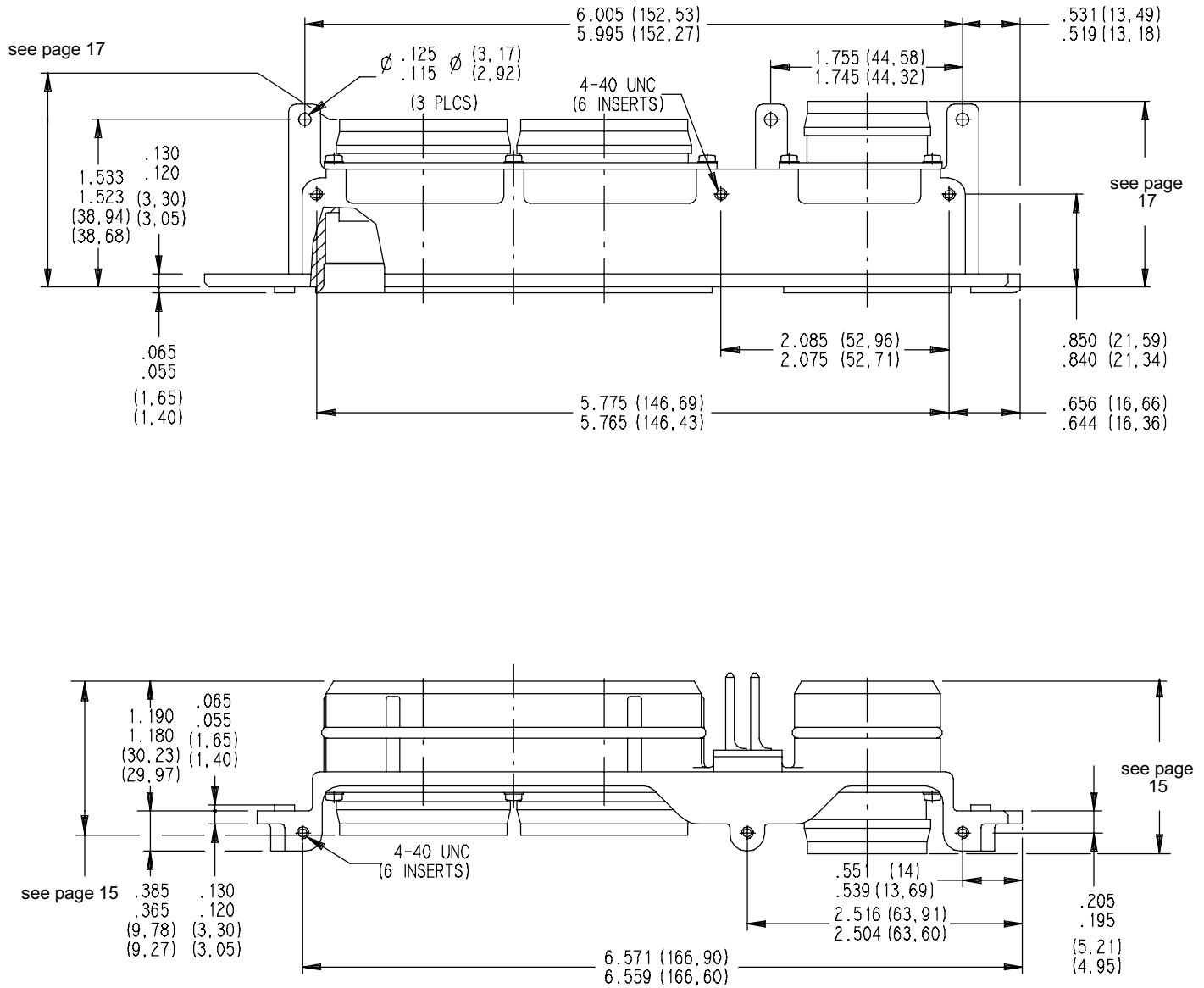

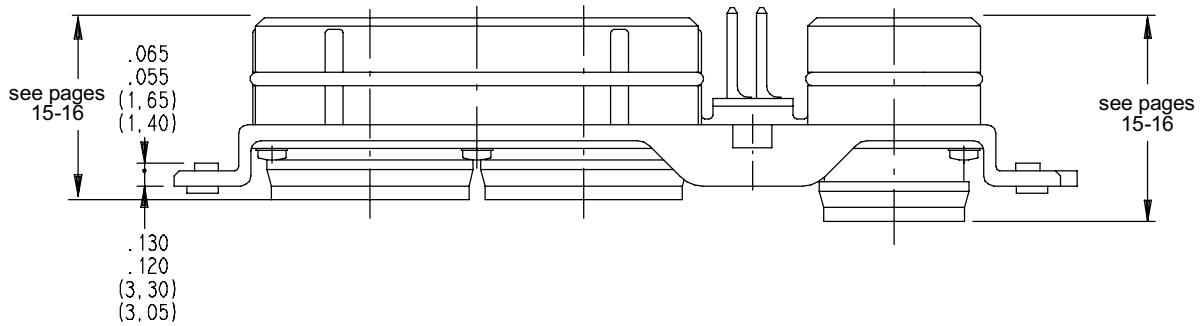
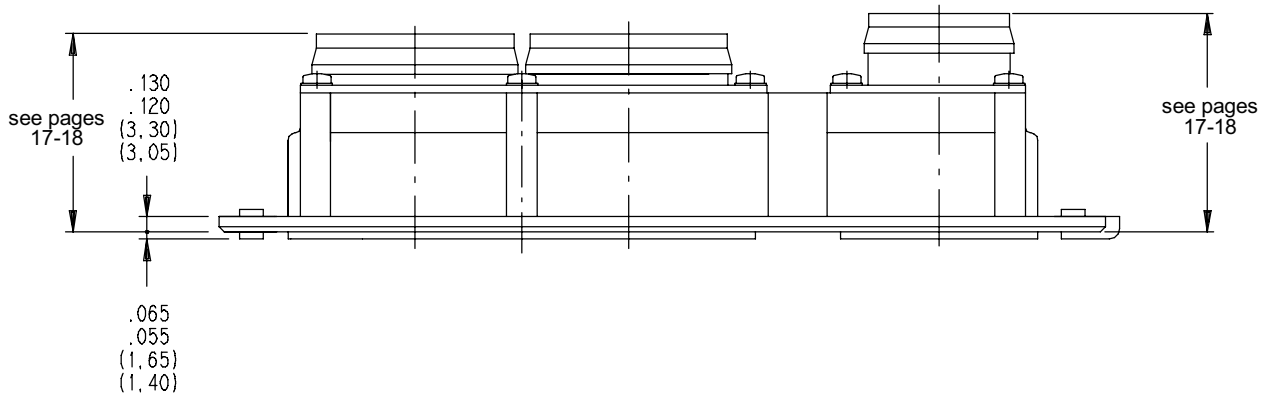

Shell size	Cavity	Contact arrangement	Contact size	Class N mm (inch) max	Class E, H, C mm (inch) max
1	A, B	60	22	28 (1.102)	35.5 (1.398)
		30T2	22	28 (1.102)	35.5 (1.398)
			8		36.8 (1.449)
	4C	5	30.5 (1.200)	-	
	C	5C2	16	30.5 (1.200)	39.3 (1.547)
			12		
			5		
		40	22	28 (1.102)	35.5 (1.398)
4	12	30.5 (1.200)	39.3 (1.547)		
2, 3	A, B, D, E	150	22	28 (1.102)	35.5 (1.398)
		121	22	28 (1.102)	35.5 (1.398)
			20	30.5 (1.200)	39.3 (1.547)
			16		
		120T2	22	28 (1.102)	35.5 (1.398)
			8		36.8 (1.449)
		118Q2	22	28 (1.102)	35.5 (1.398)
			8	28 (1.102)	36.8 (1.449)
		73C3	22	28 (1.102)	35.5 (1.398)
			coax		-
		71C1	22	28 (1.102)	35.5 (1.398)
			1		-
		1C71	22	28 (1.102)	35.5 (1.398)
			1		-
		60	20	30.5 (1.200)	39.3 (1.547)
		24	12	30.5 (1.200)	39.3 (1.547)
		10T10	8	30.5 (1.200)	39.3 (1.547)
		Q11	8	30.5 (1.200)	39.3 (1.547)
		C2	1	28 (1.102)	-
		2C	1	28 (1.102)	-
		C4	1	28 (1.102)	-
		35	16	30.5 (1.200)	39.3 (1.547)
		110	22	28 (1.102)	-
			20	30.5 (1.200)	
			12		
		36F36	16 LuxCis	30.5 (1.200)	39 (1.535)
		20F12Q8	8	30.5 (1.200)	39 (1.535)
			16 LuxCis		
20F12T8	8	30.5 (1.200)	39 (1.535)		
	16 LuxCis				

Shell size	Cavity	Contact arrangement	Contact size	Class N mm (inch) max	Class E, H, C mm (inch) max
2, 3	C, F	100	22	28 (1.102)	35.5 (1.398)
		85	22	28 (1.102)	35.5 (1.398)
			20		39.3 (1.547)
			16		
		34	20	30.5 (1.200)	39.3 (1.547)
			16		
		20T4	20	30.5 (1.200)	39.3 (1.547)
			8		
		20Q4	20	30.5 (1.200)	39.3 (1.547)
			8		
		13C2	20	30.5 (1.200)	39.3 (1.547)
			16		
			12		
			5		
		6T6	8	30.5 (1.200)	39.3 (1.547)
		Q6	8	30.5 (1.200)	39.3 (1.547)
		62Q2	22	28 (1.102)	36.8 (1.449)
			16		
			8		
		68Q2	22	28 (1.102)	35.5 (1.398)
			8		36.8 (1.449)
		11Q2	20	30.5 (1.200)	39.3 (1.547)
			16		
			12		
			8		
		11WQ2	20	30.5 (1.200)	39.3 (1.547)
			16		
			12		
8					
6P6	8	30.5 (1.200)	39.3 (1.547)		
59	22	28 (1.102)	35.5 (1.398)		
	16	30.5 (1.200)	39.3 (1.547)		
	12				
12F5C2	16 LuxCis	30.5 (1.200)	39 (1.535)		
	16				
	5				
17F12Q2	16 LuxCis	30.5 (1.200)	39 (1.535)		
	16				
	12				
	5				

Shell size	Cavity	Contact arrangement	Contact size	Class N mm (inch) max	Class E, H, C mm (inch) max	Class F mm (inch)	Class G mm (inch)
1	A, B	60	22	31 (1.220)	38.9 (1.531)	30.93/29.84 (1.218/1.175)	-
		30T2	22	31 (1.220)	38.9 (1.531)	30.93/29.84 (1.218/1.175)	30.93/29.84 (1.218/1.175)
			8		40.5 (1.594)		
	4C	5	33.45 (1.317)	-	-	30.93/29.84 (1.218/1.175)	
	C	5C2	16	33.45 (1.317)	43 (1.693)	-	30.93/29.84 (1.218/1.175)
			12				
			5				
		40	22	31 (1.220)	38.9 (1.531)	30.93/29.84 (1.218/1.175)	-
	4	12	33.45 (1.317)	43 (1.693)	-	-	
	2, 3	A, B, D, E	150	22	31 (1.220)	38.9 (1.531)	30.93/29.84 (1.218/1.175)
121			22	31 (1.220)	38.9 (1.531)	30.93/29.84 (1.218/1.175)	30.93/29.84 (1.218/1.175)
			20	33.45 (1.317)	43 (1.693)	33.45 (1.317)	
			16				
120T2			22	31 (1.220)	38.9 (1.531)	30.93/29.84 (1.218/1.175)	-
			8	31 (1.220)	40.5 (1.594)	30.93/29.84 (1.218/1.175)	-
118Q2			22	31 (1.220)	38.9 (1.531)	30.93/29.84 (1.218/1.175)	-
			8	31 (1.220)	40.5 (1.594)	30.93/29.84 (1.218/1.175)	-
73C3			22	31 (1.220)	38.9 (1.531)	30.93/29.84 (1.218/1.175)	-
			coax		-		
71C1			22	31 (1.220)	38.9 (1.531)	30.93/29.84 (1.218/1.175)	-
			1		-		
1C71			22	31 (1.220)	38.9 (1.531)	30.93/29.84 (1.218/1.175)	-
			1		-		
60			20	33.45 (1.317)	43 (1.693)	-	30.93/29.84 (1.218/1.175)
24			12	33.45 (1.317)	43 (1.693)	-	30.93/29.84 (1.218/1.175)
10T10			8	33.45 (1.317)	43 (1.693)	-	30.93/29.84 (1.218/1.175)
Q11			8	33.45 (1.317)	43 (1.693)	-	30.93/29.84 (1.218/1.175)
C2			1	31 (1.220)	-	-	-
2C			1	31 (1.220)	-	-	-
C4	1	31 (1.220)	-	-	-		
35	16	33.45 (1.317)	43 (1.693)	-	30.93/29.84 (1.218/1.175)		
110	22	31 (1.220)	38.9 (1.531)	30.93/29.84 (1.218/1.175)	30.93/29.84 (1.218/1.175)		
	20	33.45 (1.317)	43 (1.693)	33.45 (1.317)			
	12						

Shell size	Cavity	Contact arrangement	Contact size	Class N mm (inch) max	Class E, H, C mm (inch) max	Class F mm (inch)	Class G mm (inch)	
2, 3	A, B, D, E	36F36	16 LuxCis	35.5 (1.398)	44 (1.732)	-	-	
		20F12Q8	16 LuxCis	35.5 (1.398)	44 (1.732)	-	30.93/29.84 (1.218/1.175)	
			8					
		20F12T8	16 LuxCis	35.5 (1.398)	44 (1.732)	-	30.93/29.84 (1.218/1.175)	
			8					
		C, F	100	22	31 (1.220)	38.9 (1.531)	30.93/29.84 (1.218/1.175)	-
	85		22	31 (1.220)	38.9 (1.531)	30.93/29.84 (1.218/1.175)	30.93/29.84 (1.218/1.175)	
			20		40.5 (1.595)			
			16					
	34		20	33.45 (1.317)	43 (1.693)	-	30.93/29.84 (1.218/1.175)	
			16					
	20T4		20	33.45 (1.317)	43 (1.693)	-	30.93/29.84 (1.218/1.175)	
			8					
	20Q4		20	33.45 (1.317)	43 (1.693)	-	30.93/29.84 (1.218/1.175)	
			8					
	13C2		20	33.45 (1.317)	43 (1.693)	-	30.93/29.84 (1.218/1.175)	
			16					
			12					
			5					
	6T6		8	33.45 (1.317)	43 (1.693)	-	30.93/29.84 (1.218/1.175)	
	Q6		8	33.45 (1.317)	43 (1.693)	-	30.93/29.84 (1.218/1.175)	
	62Q2		22	31 (1.220)	38.9 (1.531)	40.5 (1.595)	30.93/29.84 (1.218/1.175)	30.93/29.84 (1.218/1.175)
			16					
			8					
	68Q2		22	31 (1.220)	38.9 (1.531)	40.5 (1.595)	30.93/29.84 (1.218/1.175)	30.93/29.84 (1.218/1.175)
			8					
	11Q2		20	33.45 (1.317)	43 (1.693)	-	30.93/29.84 (1.218/1.175)	
			16					
			12					
		8						
11WQ2	20	33.45 (1.317)	43 (1.693)	-	30.93/29.84 (1.218/1.175)			
	16							
	12							
	8							
6P6	8	33.45 (1.317)	43 (1.693)	-	-			
59	22	31 (1.220)	38.9 (1.531)	30.93/29.84 (1.218/1.175)	30.93/29.84 (1.218/1.175)			
	16	33.45 (1.317)	43 (1.693)	33.45 (1.317)				
	12							
12F5C2	16 LuxCis	35.5 (1.398)	44 (1.732)	-	-			
	16							
	5							
17F12Q2	16 LuxCis	35.5 (1.398)	44 (1.732)	-	30.93/29.84 (1.218/1.175)			
	16							
	12							
	5							

CLASS F : size 22 contacts are front release, front removable. Other sizes are rear release, rear removable.
 CLASS G : all contacts are front release, front removable.

POSITION OF POLARIZATION KEYS AND POSTS

Connectors are shown front side, with "RADIALL" upward

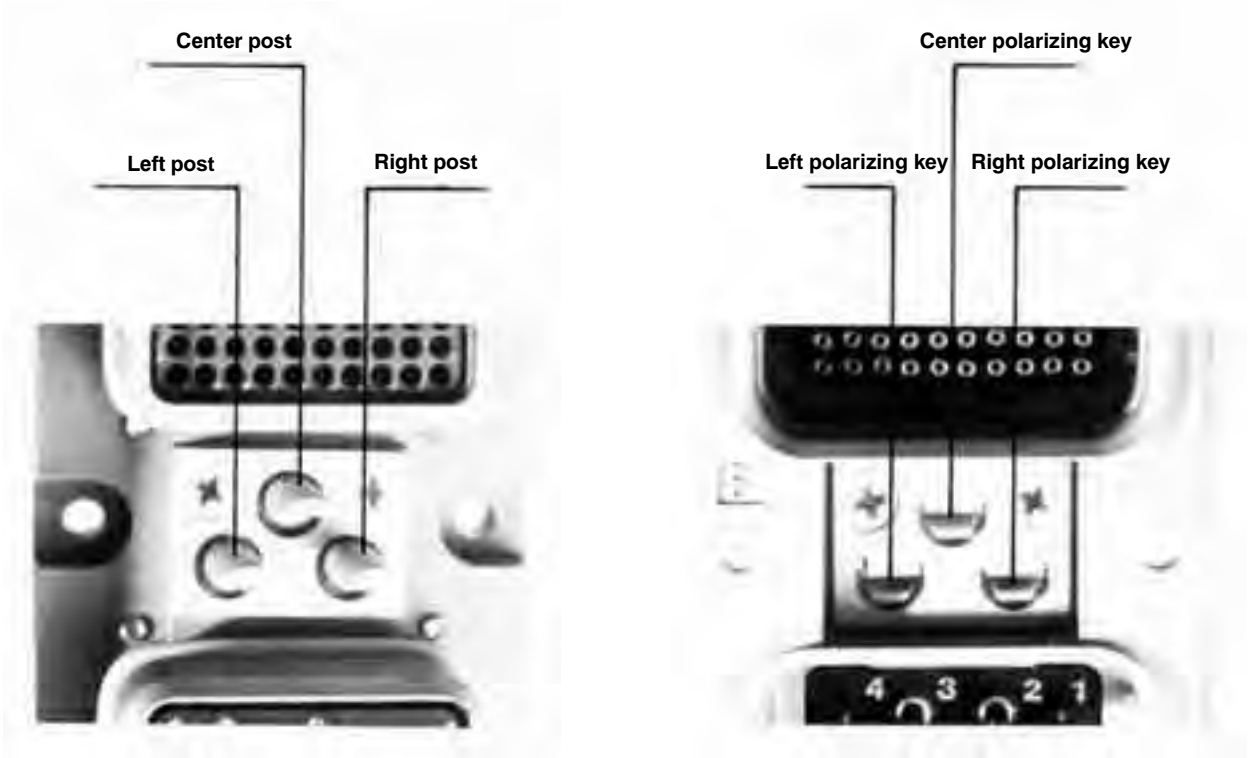

POSITION CODING

Dark area represents the polarizing post

Clear portion represents the key hole

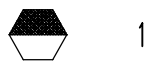

1



2



3



4

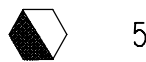

5



6

Code number	RECEPTACLE SHELL			PLUG SHELL		
	Left key	Center key	Right key	Left post	Center post	Right post
00	-	-	-	-	-	-
01	4	4	4	1	1	1
02	4	4	3	2	1	1
03	4	4	2	3	1	1
04	4	4	1	4	1	1
05	4	4	6	5	1	1
06	4	4	5	6	1	1
07	5	4	4	1	1	6
08	5	4	3	2	1	6
09	5	4	2	3	1	6
10	5	4	1	4	1	6
11	5	4	6	5	1	6
12	5	4	5	6	1	6
13	6	4	4	1	1	5
14	6	4	3	2	1	5
15	6	4	2	3	1	5
16	6	4	1	4	1	5
17	6	4	6	5	1	5
18	6	4	5	6	1	5
19	1	4	4	1	1	4
20	1	4	3	2	1	4
21	1	4	2	3	1	4
22	1	4	1	4	1	4
23	1	4	6	5	1	4
24	1	4	5	6	1	4
25	2	4	4	1	1	3
26	2	4	3	2	1	3
27	2	4	2	3	1	3
28	2	4	1	4	1	3
29	2	4	6	5	1	3
30	2	4	5	6	1	3
31	3	4	4	1	1	2
32	3	4	3	2	1	2
33	3	4	2	3	1	2
34	3	4	1	4	1	2
35	3	4	6	5	1	2
36	3	4	5	6	1	2
37	4	3	4	1	2	1
38	4	3	3	2	2	1
39	4	3	2	3	2	1
40	4	3	1	4	2	1
41	4	3	6	5	2	1
42	4	3	5	6	2	1
43	5	3	4	1	2	6
44	5	3	3	2	2	6
45	5	3	2	3	2	6
46	5	3	1	4	2	6
47	5	3	6	5	2	6
48	5	3	5	6	2	6
49	6	3	4	1	2	5

Code number	RECEPTACLE SHELL			PLUG SHELL		
	Left key	Center key	Right key	Left post	Center post	Right post
50	6	3	3	2	2	5
51	6	3	2	3	2	5
52	6	3	1	4	2	5
53	6	3	6	5	2	5
54	6	3	5	6	2	5
55	1	3	4	1	2	4
56	1	3	3	2	2	4
57	1	3	2	3	2	4
58	1	3	1	4	2	4
59	1	3	6	5	2	4
60	1	3	5	6	2	4
61	2	3	4	1	2	3
62	2	3	3	2	2	3
63	2	3	2	3	2	3
64	2	3	1	4	2	3
65	2	3	6	5	2	3
66	2	3	5	6	2	3
67	3	3	4	1	2	2
68	3	3	3	2	2	2
69	3	3	2	3	2	2
70	3	3	1	4	2	2
71	3	3	6	5	2	2
72	3	3	5	6	2	2
73	4	2	4	1	3	1
74	4	2	3	2	3	1
75	4	2	2	3	3	1
76	4	2	1	4	3	1
77	4	2	6	5	3	1
78	4	2	5	6	3	1
79	5	2	4	1	3	6
80	5	2	3	2	3	6
81	5	2	2	3	3	6
82	5	2	1	4	3	6
83	5	2	6	5	3	6
84	5	2	5	6	3	6
85	6	2	4	1	3	5
86	6	2	3	2	3	5
87	6	2	2	3	3	5
88	6	2	1	4	3	5
89	6	2	6	5	3	5
90	6	2	5	6	3	5
91	1	2	4	1	3	4
92	1	2	3	2	3	4
93	1	2	2	3	3	4
94	1	2	1	4	3	4
95	1	2	6	5	3	4
96	1	2	5	6	3	4
97	2	2	4	1	3	3
98	2	2	3	2	3	3
99	2	2	2	3	3	3



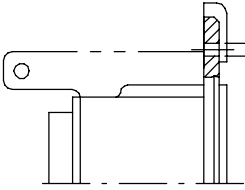
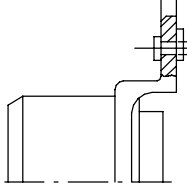
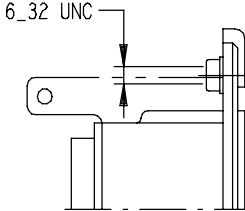
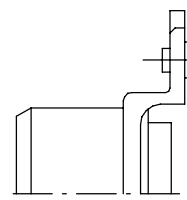
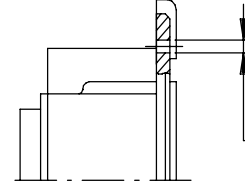
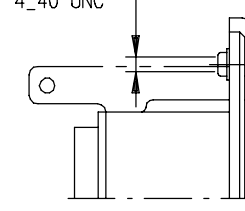
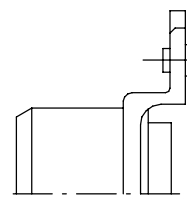
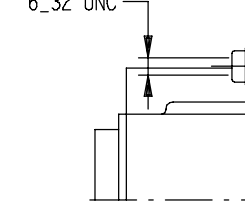
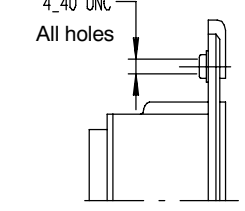
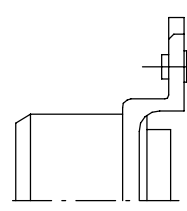

Code number	RECEPTACLE SHELL			PLUG SHELL		
	Left key	Center key	Right key	Left post	Center post	Right post
100	2	2	1	4	3	3
101	2	2	6	5	3	3
102	2	2	5	6	3	3
103	3	2	4	1	3	2
104	3	2	3	2	3	2
105	3	2	2	3	3	2
106	3	2	1	4	3	2
107	3	2	6	5	3	2
108	3	2	5	6	3	2
109	4	1	4	1	4	1
110	4	1	3	2	4	1
111	4	1	2	3	4	1
112	4	1	1	4	4	1
113	4	1	6	5	4	1
114	4	1	5	6	4	1
115	5	1	4	1	4	6
116	5	1	3	2	4	6
117	5	1	2	3	4	6
118	5	1	1	4	4	6
119	5	1	6	5	4	6
120	5	1	5	6	4	6
121	6	1	4	1	4	5
122	6	1	3	2	4	5
123	6	1	2	3	4	5
124	6	1	1	4	4	5
125	6	1	6	5	4	5
126	6	1	5	6	4	5
127	1	1	4	1	4	4
128	1	1	3	2	4	4
129	1	1	2	3	4	4
130	1	1	1	4	4	4
131	1	1	6	5	4	4
132	1	1	5	6	4	4
133	2	1	4	1	4	3
134	2	1	3	2	4	3
135	2	1	2	3	4	3
136	2	1	1	4	4	3
137	2	1	6	5	4	3
138	2	1	5	6	4	3
139	3	1	4	1	4	2
140	3	1	3	2	4	2
141	3	1	2	3	4	2
142	3	1	1	4	4	2
143	3	1	6	5	4	2
144	3	1	5	6	4	2
145	4	6	4	1	5	1
146	4	6	3	2	5	1
147	4	6	2	3	5	1
148	4	6	1	4	5	1
149	4	6	6	5	5	1
150	4	6	5	6	5	1
151	5	6	4	1	5	6
152	5	6	3	2	5	6
153	5	6	2	3	5	6
154	5	6	1	4	5	6
155	5	6	6	5	5	6
156	5	6	5	6	5	6
157	6	6	4	1	5	5
158	6	6	3	2	5	5

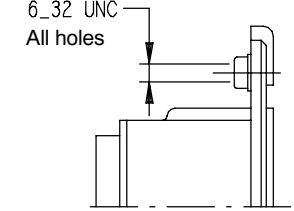
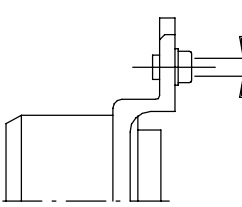
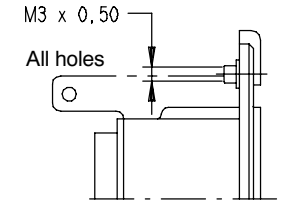
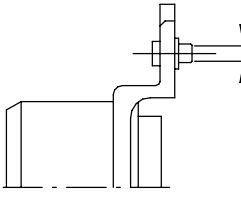
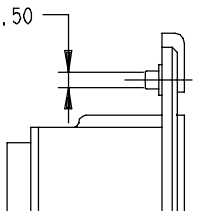
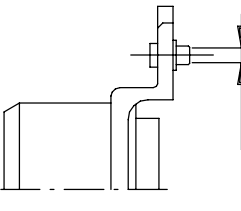
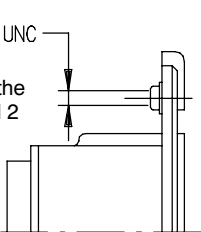
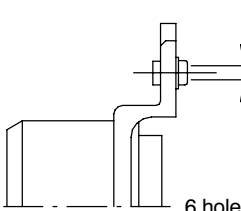
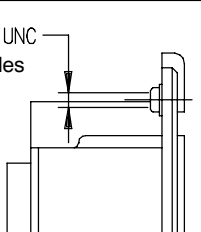
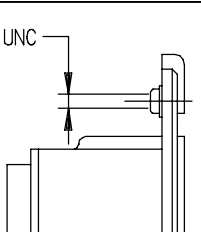
Code number	RECEPTACLE SHELL			PLUG SHELL		
	Left key	Center key	Right key	Left post	Center post	Right post
159	6	6	2	3	5	5
160	6	6	1	4	5	5
161	6	6	6	5	5	5
162	6	6	5	6	5	5
163	1	6	4	1	5	4
164	1	6	3	2	5	4
165	1	6	2	3	5	4
166	1	6	1	4	5	4
167	1	6	6	5	5	4
168	1	6	5	6	5	4
169	2	6	4	1	5	3
170	2	6	3	2	5	3
171	2	6	2	3	5	3
172	2	6	1	4	5	3
173	2	6	6	5	5	3
174	2	6	5	6	5	3
175	3	6	4	1	5	2
176	3	6	3	2	5	2
177	3	6	2	3	5	2
178	3	6	1	4	5	2
179	3	6	6	5	5	2
180	3	6	5	6	5	2
181	4	5	4	1	6	1
182	4	5	3	2	6	1
183	4	5	2	3	6	1
184	4	5	1	4	6	1
185	4	5	6	5	6	1
186	4	5	5	6	6	1
187	5	5	4	1	6	6
188	5	5	3	2	6	6
189	5	5	2	3	6	6
190	5	5	1	4	6	6
191	5	5	6	5	6	6
192	5	5	5	6	6	6
193	6	5	4	1	6	5
194	6	5	3	2	6	5
195	6	5	2	3	6	5
196	6	5	1	4	6	5
197	6	5	6	5	6	5
198	6	5	5	6	6	5
199	1	5	4	1	6	4
200	1	5	3	2	6	4
201	1	5	2	3	6	4
202	1	5	1	4	6	4
203	1	5	6	5	6	4
204	1	5	5	6	6	4
205	2	5	4	1	6	3
206	2	5	3	2	6	3
207	2	5	2	3	6	3
208	2	5	1	4	6	3
209	2	5	6	5	6	3
210	2	5	5	6	6	3
211	3	5	4	1	6	2
212	3	5	3	2	6	2
213	3	5	2	3	6	2
214	3	5	1	4	6	2
215	3	5	6	5	6	2
216	3	5	5	6	6	2

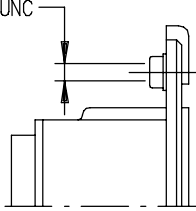
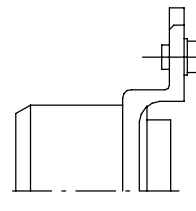
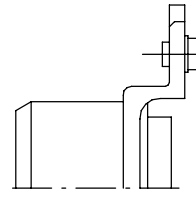
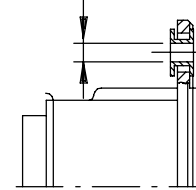
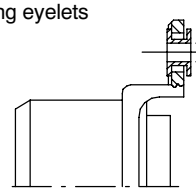
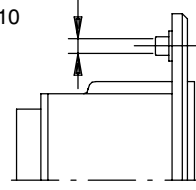
RECEPTACLE SHELL	CODE	PLUG SHELL
 <p> $\varnothing .148$ $\varnothing (3.76)$ All holes </p>	00	 <p> $\varnothing .148$ $\varnothing (3.76)$ All holes </p>
 <p> 6_32 UNC Shell size 1 : Q^{ty} = 4 Shell size 2 : Q^{ty} = 6 Shell size 3 : Q^{ty} = 10 </p>	01	 <p> Shell size 1 : Q^{ty} = 4 Shell size 2 : Q^{ty} = 4 Shell size 3 : Q^{ty} = 8 6_32 UNC Size 1 plug is without threaded inserts </p>
 <p> Available for shell size 1 only $\varnothing .148$ $\varnothing (3.76)$ All holes </p>	02	
 <p> 4_40 UNC Shell size 1 : Q^{ty} = 4 Shell size 2 : Q^{ty} = 6 Shell size 3 : Q^{ty} = 10 </p>	03	 <p> Shell size 1 : Q^{ty} = 4 Shell size 2 : Q^{ty} = 4 Shell size 3 : Q^{ty} = 8 4_40 UNC Size 1 plug is without threaded inserts </p>
 <p> 6_32 UNC Available for shell size 1 only Q^{ty} = 4 </p>	04	
 <p> 4_40 UNC All holes Shell sizes 2 and 3 only </p>	08	 <p> Shell sizes 2 and 3 only 4_40 UNC All holes </p>

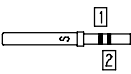
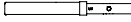
RECEPTACLE SHELL	CODE	PLUG SHELL
 <p>6_32 UNC All holes</p> <p>Shell sizes 2 and 3 only</p>	<p>09</p>	 <p>Shell sizes 2 and 3 only</p> <p>6_32 UNC All holes</p>
 <p>M3 x 0,50 All holes</p> <p>Size 1 receptacle is without threaded inserts</p>	<p>10</p>	 <p>M3 x 0,5 All holes</p> <p>Size 1 plug is without threaded inserts</p>
 <p>M3 x 0,50</p> <p>Shell size 1 : Q^{ty} = 4 Shell size 2 : Q^{ty} = 6 Shell size 3 : Q^{ty} = 10</p> <p>Size 1 receptacle is without threaded inserts</p>	<p>11</p>	 <p>Shell size 1 : Q^{ty} = 4 Shell size 2 : Q^{ty} = 4 Shell size 3 : Q^{ty} = 8</p> <p>M3 x 0,5</p> <p>Size 1 plug is without threaded inserts</p>
 <p>4_40 UNC 6 holes (4 close to the bosses and 2 at the polarization system level)</p> <p>Available for shell size 2 only</p>	<p>12</p>	 <p>Available for shell size 2 only</p> <p>4_40 UNC</p> <p>6 holes (4 in to the corner, 2 at the polarization system level)</p>
 <p>4_40 UNC All holes</p> <p>Available for shell size 1 only</p>	<p>13</p>	
 <p>4_40 UNC</p> <p>Available for shell size 3 only Q^{ty} = 8</p>	<p>14</p>	

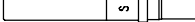
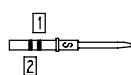
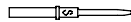
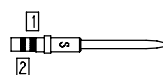
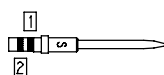
RECEPTACLE SHELL	CODE	PLUG SHELL
 <p>6_32 UNC</p> <p>Shell size 2 : Qty = 8 Shell size 3 : Qty = 12</p>	<p>15</p>	 <p>6_32 UNC</p> <p>Shell size 2 : Qty = 8 Shell size 3 : Qty = 12</p>
	<p>16</p>	 <p>6_32 UNC</p> <p>Qty = 6</p> <p>Available for shell size 2 only</p>
 <p>Size 2 and 3 { \varnothing .141 \varnothing (3,6) }</p> <p>Size 1 { \varnothing .122 \varnothing (3.1) }</p> <p>4 floating eyelets</p>	<p>23</p>	 <p>4 floating eyelets</p> <p>\varnothing .122 } Size 1 \varnothing (3.1) }</p> <p>\varnothing .141 } Size 2 \varnothing (3,6) } and 3</p>
 <p>M3 x 0.50</p> <p>Qty = 10</p> <p>Shell without boss</p> <p>Available for shell size 2 only</p>	<p>30</p>	

INS. EXT TOOL (metallic)	RADIALL P/N	282 885		282 886	282 546	
	MIL SPEC P/N	M 81 969/1.01		M 81 969/1.02	M 81 969/1.03	
INS. EXT TOOL (plastic)	RADIALL P/N	282 549 028		282 549 029	282 515	
	MIL SPEC P/N	M 81 969/14.01		M 81 969/14.02	M 81 969/14.03	
POSITIONER	RADIALL P/N	282 970		282 971	282 972	
	MIL SPEC P/N	M 22 520/2.23		M 22 520/2.08	M 22 520/1.02	
CRIMPING TOOL	RADIALL P/N	282 281		282 281	282 291	
	MIL SPEC P/N	M 22 520/2.01		M 22 520/2.01	M 22 520/1.01	
CONTACT	SOCKET	620 300  1 orange 2 green	620 301 	620 310  1 orange 2 red	620 330  1 orange 2 blue	620 331 
	PIN	620 200  1 orange 2 green	620 201 	620 210  1 orange 2 red	620 230  1 orange 2 blue	620 231 
WIRE	SELECTOR	4-3-3	5-4	5-6-7	6-5-4	5-4-3-2
	STRIPING LENGTH ± .020 inch (mm)	.138 (3.5)		.157 (4)	.236 (6)	
	WIRE OUTSIDE DIAMETER inch (mm)	.055 (1.4)	.047 (1.2)	.071 (1.8)	.102 (2.6)	.077 (1.97)
	CROSS SECTION (mm ²)	0.38-0.21-0.14	0.093-0.055	0.21-0.38-0.60	1.34-0.93-0.60	0.93-0.60-0.38-0.21
	WIRE SIZE (AWG)	22-24-26	28-30	24-22-20	16-18-20	18-20-22-24
CONTACT ARRANGEMENT	See shell contact arrangement page 78 to 87					
CONTACT SIZE	22	22 reduced crimp barrel	20	16	16 reduced crimp barrel	

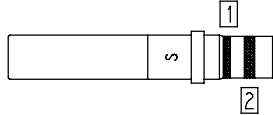
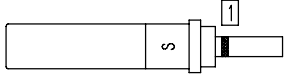
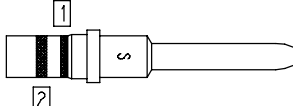
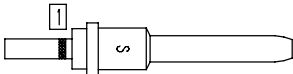
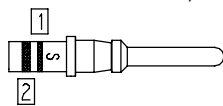
INS. EXT TOOL (metallic)	RADIALL P/N	282 547		
	MIL SPEC P/N	M 81 969/28.02		M 81 969/19.02
INS. EXT TOOL (plastic)	RADIALL P/N	282 549 004		
	MIL SPEC P/N	M 81 969/14.04		
POSITIONER	RADIALL P/N	282 972		282 579
	MIL SPEC P/N	M 22 520/1.02		M 22 520/1.11
CRIMPING TOOL	RADIALL P/N	282 291		
	MIL SPEC P/N	M 22 520/1.01		
CONTACT	SOCKET	620 340  1 orange 2 yellow	620 341  1 orange	
	PIN	620 240  1 orange 2 yellow	620 241  1 orange	619 240 (front release rear removable contact)  1 orange 2 yellow
WIRE	SELECTOR	8-7-6	2-3-4-5	8-7-6
	STRIPING LENGTH ± .020 inch (mm)	.236 (6)		
	WIRE OUTSIDE DIAMETER inch (mm)	.134 (3.4)	.094 (2.4)	.134 (3.4)
	CROSS SECTION (mm ²)	3.18-1.91-1.34	0.93-0.60-0.38-0.21	3.18-1.91-1.34
	WIRE SIZE (AWG)	12-14-16	18-20-22-24	12-14-16
CONTACT ARRANGEMENT	See shell contact arrangement page 78 to 87			
CONTACT SIZE	12	12 reduced crimp barrel	12	

Please note Radiall recommends plastic extraction tool for environmental cavities 22-20-16 and 12 (the metallic extraction tool leads to damage risk of triple silicon web).

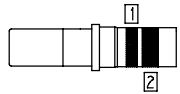
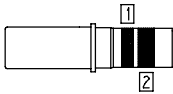
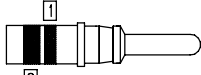
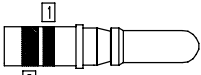
EXT TOOL (metallic)	RADIALL P/N	socket: 282 549 001 pin: 282 549 012	282 549 012	282 540 001	282 548	
	MIL SPEC P/N	socket: M 81 969/28.03 pin: M 81 969/19.03	M 81 969/19.03	M 81 969/28.03	M 81 969/28.01	
POSITIONNER	RADIALL P/N			282 588	282 557	
	MIL SPEC P/N	M 22 520/23.09				
DIE	RADIALL P/N					
	MIL SPEC P/N	M 22 520/23.02				
CRIMPING TOOL	RADIALL P/N				282 296	
	MIL SPEC P/N	M 22 520/23.01		M 22 520/ 23.01		
CONTACT	SOCKET	619 370  1 orange 2 brown		619 371  1 orange 2 black	616 361	616 366
	PIN	619 270 (front release rear removable contact)  1 orange 2 brown	619 271 (front release rear removable contact)  1 orange 2 black		616 261	616 266
WIRE	SELECTOR				1-1	8-5
	STRIPING LENGTH ± .020 inch (mm)	.453 (11.5)		.315 (8.0)		
	WIRE OUTSIDE DIAMETER inch (mm)	.224 (5.7)		.134 (3.4)		.234 (5.7)
	CROSS SECTION (mm ²)	9-5		3.18-1.91		9-5
	WIRE SIZE (AWG)	8-10		12-14		8-10
CONTACT ARRANGEMENT	See shell contact arrangement page 78 to 87					
CONTACT SIZE	8	8 ground		5		

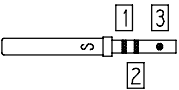
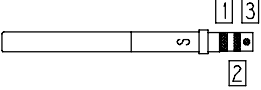
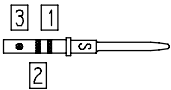
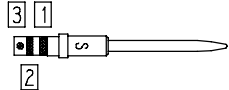
INS. EXT TOOL	RADIALL P/N	282 885	282 886
	MIL SPEC P/N	M 81 969/1.01	M 81 969/1.02
POSITIONER	RADIALL P/N	282 970	282 971
	MIL SPEC P/N	M 22 520/2.23	M 22 520/2.08
CRIMPING TOOL	RADIALL P/N	282 281	
	MIL SPEC P/N	M 22 520/2.01	
CONTACT	SOCKET	<p>620 380</p>  <p>1 orange 2 green 3 yellow</p>	<p>620 390</p>  <p>1 orange 2 red 3 yellow</p>
	PIN	<p>620 280</p>  <p>1 orange 2 green 3 yellow</p>	<p>620 290</p>  <p>1 orange 2 red 3 yellow</p>
WIRE	SELECTOR	4-3-3	7-6-5
	STRIPING LENGTH ± .020 inch (mm)	.138 (3.5)	.157 (4)
	WIRE OUTSIDE DIAMETER inch (mm)	.055 (1.4)	.071 (1.8)
	CROSS SECTION (mm ²)	0.38-0.21-0.14	0.60-0.38-0.21
	WIRE SIZE (AWG)	22-24-26	20-22-24
CONTACT ARRANGEMENT	See shell contact arrangement page 78 to 87		
CONTACT SIZE	22	20	

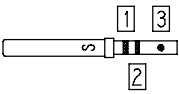
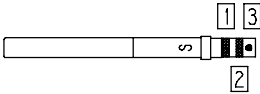
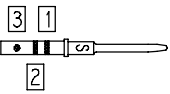
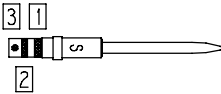
INS. EXT TOOL	RADIALL P/N	282 885	282 886
	MIL SPEC P/N	M 81 969/1.01	M 81 969/1.02
POSITIONER	RADIALL P/N	282 970	282 971
	MIL SPEC P/N	M 22 520/2.23	M 22 520/2.08
CRIMPING TOOL	RADIALL P/N	282 281	
	MIL SPEC P/N	M 22 520/2.01	
CONTACT	SOCKET	<p>620 381</p>  <p>1 orange 2 green 3 black</p>	<p>620 391</p>  <p>1 orange 2 red 3 black</p>
	PIN	<p>620 281</p>  <p>1 orange 2 green 3 black</p>	<p>620 291</p>  <p>1 orange 2 red 3 black</p>
WIRE	SELECTOR	4-3-3	7-6-5
	STRIPING LENGTH ± .020 inch (mm)	.138 (3.5)	.157 (4)
	WIRE OUTSIDE DIAMETER inch (mm)	.055 (1.4)	.071 (1.8)
	CROSS SECTION (mm ²)	0.38-0.21-0.14	0.60-0.38-0.21
	WIRE SIZE (AWG)	22-24-26	20-22-24
CONTACT ARRANGEMENT	See shell contact arrangement page 78 to 87		
CONTACT SIZE	22	20	

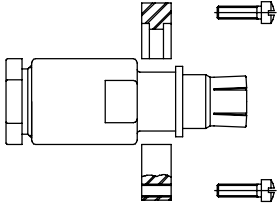
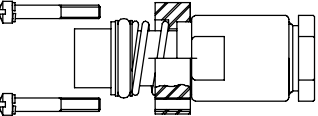
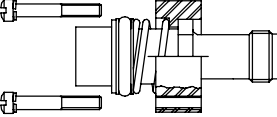
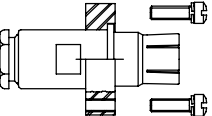
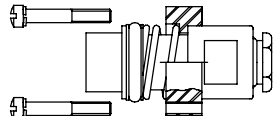
WIRE	TYPE	PART NUMBER	CONTACT	CONTACT ARRANGEMENTS	WIRING INSTRUCTIONS
RG 214 RG 393	Pin	620 001		71C1-1C71-C2	A (Page 43)
	Socket	620 101			
		620 101 001	Identical to 620 101 without O-ring		
Not applicable TNC termination	Socket	620 101 003		71C1-1C71-C2	Not applicable
		620 101 004	Identical to 620 101 003 without O-ring		
RG 223 RG 142	Pin	620 003		71C1-1C71-C2	B (Page 44)
	Socket	620 103			C (Page 45)

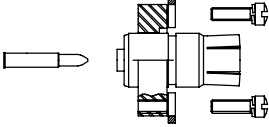
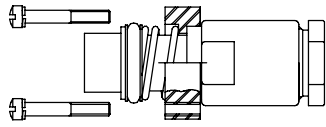
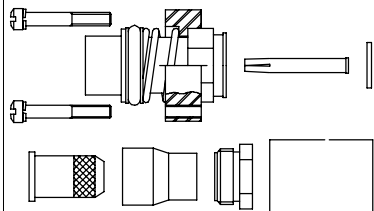
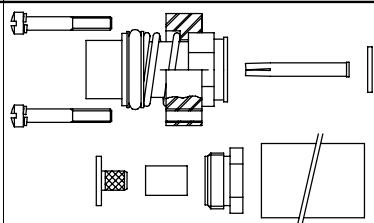
WIRE	TYPE	PART NUMBER	CONTACT	CONTACT ARRANGEMENTS	WIRING INSTRUCTIONS
RG 402 UT .141	Pin	620 005		71C1-1C71-C2	E (Page 47)
NSA 935 358	Socket	620 107		71C1-1C71-C2	A (Page 43)
		620 107 001	Identical to 620 107 without O-ring		
ASNE 0406 WD FILOTEX 50MFCFB and FILECA 1 703/94	Socket	620 108		71C1-1C71-C2	G (Page 48)
		620 108 001	Identical to 620 108 without O-ring		
RG 400 RG 142	Socket	620 109		71C1-1C71-C2	G (Page 48)
		620 109 001	Identical to 620 109 without O-ring		

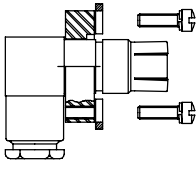
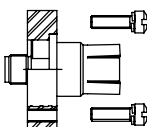
WIRE	TYPE	PART NUMBER	CONTACT	CONTACT ARRANGEMENTS	WIRING INSTRUCTIONS
RG 142	Pin	620 011		71C1-1C71-C2	D (Page 46)
Not applicable SMA termination	Pin	620 044		71C1-1C71-C2	Not applicable
ASNE0691WM	Socket	620 101 011		71C1-1C71-C2	<i>TDS contact available at http://www.radiall.com</i>
ASNE0692WN	Socket	620 101 012		71C1-1C71-C2	<i>TDS contact available at http://www.radiall.com</i>
ASNE0692WN ASNE0406WD	Pin	620 001 012		71C1-1C71-C2	<i>TDS contact available at http://www.radiall.com</i>
RD316	Pin	620 043 001		71C1-1C71-C2	<i>TDS contact available at http://www.radiall.com</i>

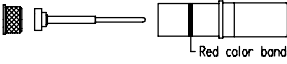
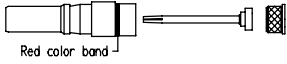
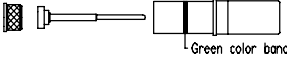
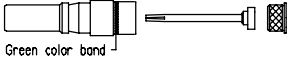
WIRE	TYPE	PART NUMBER	CONTACT	FOR INSERT	INS/EXT TOOL	WIRING INSTRUCTIONS	
ADAMS-RUSSELL FC 11Z (per S280W503-1)	Socket			for all size 8 cavities	282 549 001 (M 81 969/28.03)	H (Page 49)	
	Pin				282 549 001 (M 81 969/28.03) for ins. 282 549 012 (M 81 969/19.03) for ext.	H (Page 49) Front release rear removable contact	
ADAMS-RUSSELL FC 14Z (per S280W503-2)	Socket				282 549 001 (M 81 969/28.03)	H (Page 49)	
	Pin				282 549 001 (M 81 969/28.03) for ins. 282 549 012 (M 81 969/19.03) for ext.	H (Page 49) Front release rear removable contact	
RG400 RG412 RG223 RG55U ASNE0293XF	Socket	619 051				282 549 001 (M 81 969/28.03)	Rear release rear removable contact <i>TDS contact available at http://www.radiall.com</i>
	Socket	619 051 001 environmental					
	Pin	619 151					
	Pin	619 151 001 environmental					

WIRE	TYPE	PART NUMBER	CONTACT	FOR INSERT	INS/EXT TOOL	WIRING INSTRUCTIONS
RG316-KX22 -RG179 ASNE0639XY	Socket	619 054		for all size 8 cavities	282 549 001 (M 81 969/28.03)	Rear release rear removable contact <i>TDS contact available at http://www.radiall.com</i>
		619 054 001 environmental				
	Pin	619 154		for all size 8 cavities		Rear release rear removable contact <i>TDS contact available at http://www.radiall.com</i>
		619 154 001 environmental				
Gore GSC-03-8174 8-00	Socket	619 053		for all size 8 cavities	282 549 001 (M 81 969/28.03)	Rear release rear removable contact <i>TDS contact available at http://www.radiall.com</i>
		619 053 001 environmental				
	Pin	619 153		for all size 8 cavities		Rear release rear removable contact <i>TDS contact available at http://www.radiall.com</i>
		619 153 001 environmental				
RG180 RG195	Socket	619 052		for all size 8 cavities	282 549 001 (M 81 969/28.03)	Rear release rear removable contact <i>TDS contact available at http://www.radiall.com</i>
		619 052 001 environmental				
	Pin	619 152		for all size 8 cavities		Rear release rear removable contact <i>TDS contact available at http://www.radiall.com</i>
		619 152 001 environmental				



WIRE	TYPE	PART NUMBER	CONTACT	FOR INSERT	INS/EXT TOOL	WIRING INSTRUCTIONS
ASNE0690WL	Socket	619 054 002		for all size 8 cavities	282 549 001 (M 81 969/28.03)	Rear release rear removable contact <i>TDS contact available at http://www.radiall.com</i>
RG58 RG141	Socket	619 050			Rear release rear removable contact <i>TDS contact available at http://www.radiall.com</i>	
		619 050 001 environmental			Rear release rear removable contact <i>TDS contact available at http://www.radiall.com</i>	
	Pin	619 150			Rear release rear removable contact <i>TDS contact available at http://www.radiall.com</i>	
		619 150 001 environmental			Rear release rear removable contact <i>TDS contact available at http://www.radiall.com</i>	
RG178 KX21	Socket	619 055			Rear release rear removable contact <i>TDS contact available at http://www.radiall.com</i>	
		619 055 001 environmental			Rear release rear removable contact <i>TDS contact available at http://www.radiall.com</i>	
	Pin	619 155			Rear release rear removable contact <i>TDS contact available at http://www.radiall.com</i>	
		619 155 001 environmental		Rear release rear removable contact <i>TDS contact available at http://www.radiall.com</i>		

WIRE	TYPE	PART NUMBER	CONTACT	FOR INSERT	INS/EXT TOOL	WIRING INSTRUCTIONS
RD316	Socket	619 056		for all size 8 cavities		Rear release rear removable contact <i>TDS contact available at http://www.radiall.com</i>
		619 056 001 environmental				Rear release rear removable contact <i>TDS contact available at http://www.radiall.com</i>
	Pin	619 156				Rear release rear removable contact <i>TDS contact available at http://www.radiall.com</i>
		619 156 001 environmental				Rear release rear removable contact <i>TDS contact available at http://www.radiall.com</i>



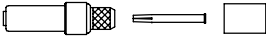
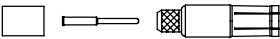
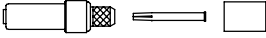
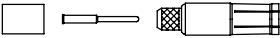

Add 001 to these P/N to order environmental contacts

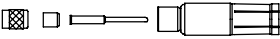
The above mentioned contacts can be fitted with sealing boots (see available sealing boots on page 69).



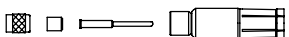
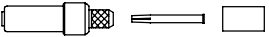
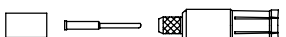

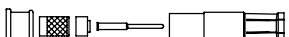

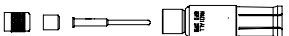
WIRE	TYPE	PART NUMBER	CONTACT	FOR INSERT	INS/EXT TOOL	WIRING INSTRUCTIONS
RG 58 RG 141	Pin	620 120*		for all size 5 cavities	282 946 (M 81 969/28.01)	P (Page 54)
	Socket	620 020*				
RG 142 RG 223 RG 400	Pin	620 121*				
	Socket	620 021*				
ASNE0639XY RG 179 RG 316 KX 22	Pin	620 122*			282 946 (M 81 969/28.01)	R (Page 55)
	Socket	620 022*				

* Add 001 to these P/N to order for environmental contacts.

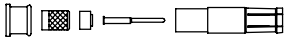

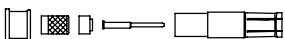
WIRE	TYPE	PART NUMBER	CONTACT	FOR INSERT	INS/EXT TOOL	WIRING INSTRUCTIONS
ASNE 0633WG RG 178 KX 21	Pin	620 123*		for all size 5 cavities	282 946 (M 81 969/28.01)	R (Page 55)
	Socket	620 023*				
RG 180 RG 195	Pin	620 124*				
	Socket	620 024*				
RAYCHEM 5021K1011	Pin	620 126 001				
	Socket	620 026 001				
RD 316	Pin	620 129*				
	Socket	620 029*				

* Add 001 to these P/N to order for environmental contacts.

WIRE	TYPE	PART NUMBER	CONTACT	FOR INSERT	INS/EXT TOOL	WIRING INSTRUCTIONS
ADAMS-RUSSELL FC 11Z (per S280W503-1)	Pin	620 182 001		for all size 5 cavities	282 946 (M 81 969/28.01)	L (Page 51)
	Socket	620 082 001				
ADAMS-RUSSELL FC 14Z (per S280W503-2)	Pin	620 183 001				
	Socket	620 083 001				
SMA termination	Pin	620 134			282 946 (M 81 969/28.01)	Not applicable
ASNE0690WL	Pin	620 184			282 946 (M 81 969/28.01)	<i>TDS contact available at http://www.radiall.com</i>
ASNE0690WL	Pin	620 084		282 946 (M 81 969/28.01)	<i>TDS contact available at http://www.radiall.com</i>	

NSX- ARINC 600

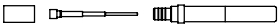
SIZE 16 COAXIAL CONTACTS & SIZE 5 CONCENTRIC TWINAX CONTACTS

WIRE	TYPE	PART NUMBER	CONTACT	FOR INSERT	INS/EXT TOOL	WIRING INSTRUCTIONS
RG 316 RG 179 ASNE0639XY ASNE0632WK ASNE0752WS	Pin	618 150		for all size 16 cavities	282 892	S (Page 56)
	Socket	618 050				
RG 178 KX 21 ASNE0633WG	Pin	618 154			282 892	T (Page 56)
	Socket	618 054				

SIZE 5 CONCENTRIC TWINAX CONTACTS

WIRE	TYPE	PART NUMBER	FOR INSERT	INS/EXT TOOL	WIRING INSTRUCTIONS
MIL C 17/17600002	Pin	616 195 001*	for all size 5 cavities	282 946 (M 81 969/28.01)	U (Page 57-58)
	Socket	616 095 001*			

* 616 195 009 and 616 095 009 contacts are the environmental versions of 616 195 001 and 616 095 001.

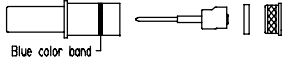
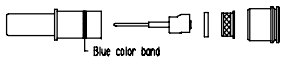
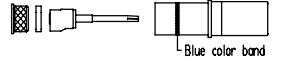
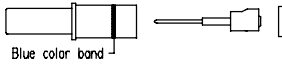

WIRE	TYPE	PART NUMBER	CONTACT	FOR INSERT	INS/EXT TOOL	WIRING INSTRUCTIONS
Tensolite (S280W502-1)	Pin	619 165		for all size 8 cavities	282 549 001 (M 81 969/28.03)	M (Page 52)
		619 165 002 (note 1)				
	Socket	619 065				
	Pin	619 166**				
MIL C 17/17600002	Pin	619 169 001		for all size 8 cavities	282 549 001 (M 81 969/28.03)	Rear release rear removable contact <i>TDS contact available at http://www.radiall.com</i>
	Socket	619 069 001				
		619 069 002 environmental				

Part number in bold letters indicates front release rear removable contact.

Note 1 : Contact delivered with a **619 960** alignment boot.

Some of the above mentioned contacts can be fitted with sealing boots (see available sealing boots on pages 69 and 115).

Pin contacts can be fitted with a **619 960** alignment boot to reduce the splay at the top of the pin contacts (see page 69).

WIRE	TYPE	PART NUMBER (non environmental)	PART NUMBER (environmental)	INS/EXT TOOL	WIRING INSTRUCTIONS
ABS972 ABS1503KD24	Pin	620 175 010	620 175 011	282 549 001 (M 81 969/28.03 or M 81 969/14.06)	<i>TDS contact available at http://www.radiall.com</i>
	Socket	620 075 010	620 075 011		
THERMAX 956S-4T200 GORE RCN8422 (110 I)	Pin	620 179 002	620 179 001		
	Socket	620 079 002	620 079 001		
TENSOLITE NF24Q100 (100 I)	Pin	620 175 050	620 175 051		
	Socket	620 075 050	620 075 051		
GORE RCN8487-1 (110 I)	Pin	620 175 021	620 175 020		
	Socket	620 075 021	620 075 020		

Please note quadrax contact are used in these inserts : Q11-68Q4-118Q2-Q6-20Q4-68Q2-62Q2-17F12Q2-11Q2-11WQ2-20F12Q8

WIRING INSTRUCTIONS A

- Trim cable at dimensions shown.

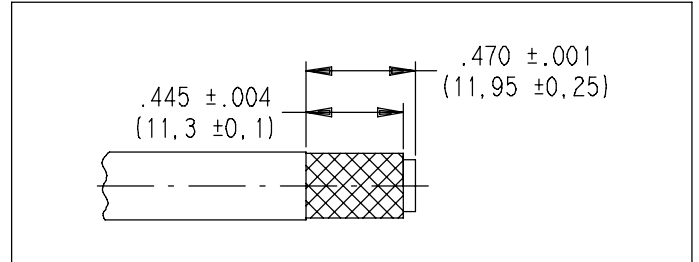

- Slide nut washer and gasket over outer jacket.
- Next slide braid clamp until it butts up against outer jacket.

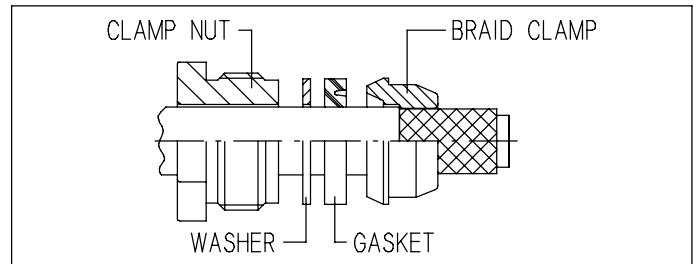

- Comb braid until all strands are straight.
- Next fold braid back over braid clamp as shown.

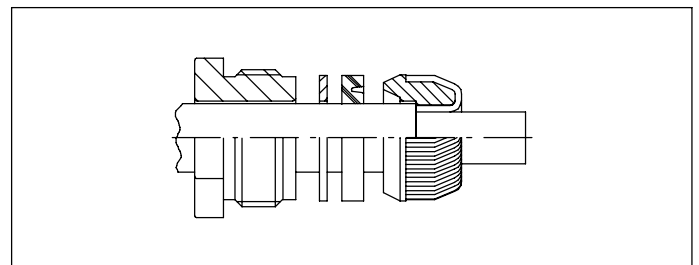

- Trim dielectric as shown (do not cut inner conductor).
- Trim inner conductor to dimension shown.

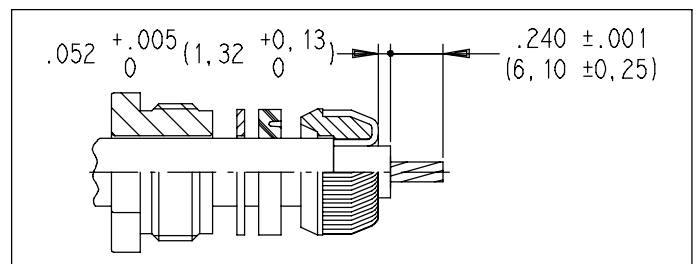

- Place contact over inner conductor until it stops against dielectric.
- Solder in place as shown.

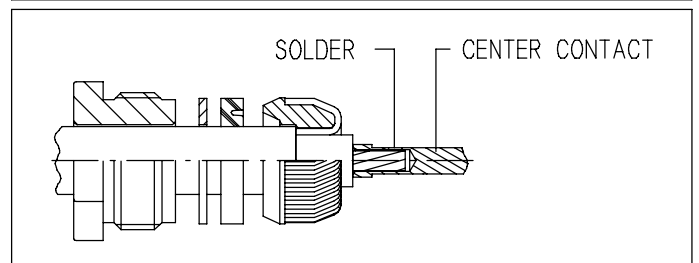

- Insert contact/cable assembly into body assy, slide gasket and washer into body assy.
- Screw clamp nut in place and tighten using 45 to 55 inch. pound torque (5 to 6 m.N).

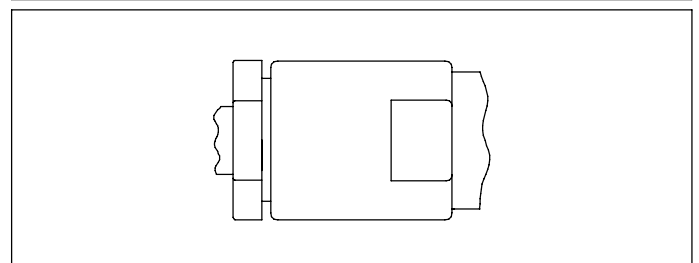

WIRING INSTRUCTIONS B

- Trim cable to dimensions shown.

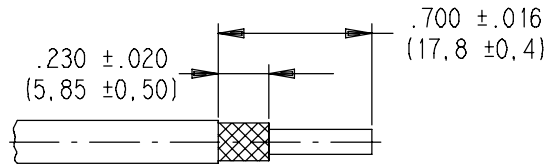

- Slide nut, washer and gasket over outer jacket.
- Next slide braid clamp until it butts up against outer jacket.

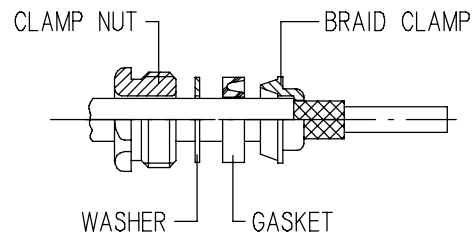

- Comb braid until all strands are straight.
- Next fold braid over braid clamp as shown.

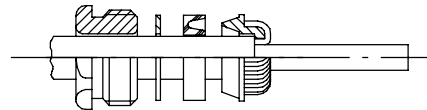

- Slide bushing over dielectric until it stops against braid.
- Trim dielectric as shown.
- Cut inner conductor to dimension shown.

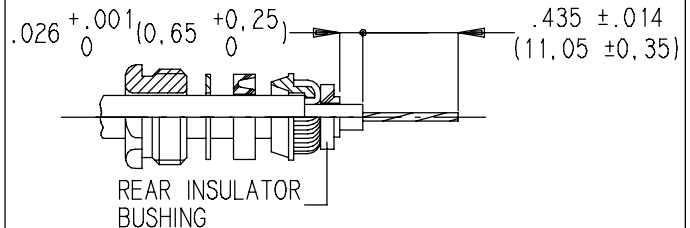

- Assemble insulator and contact over inner conductor until insulator stops against bushing.
- Solder in place as shown

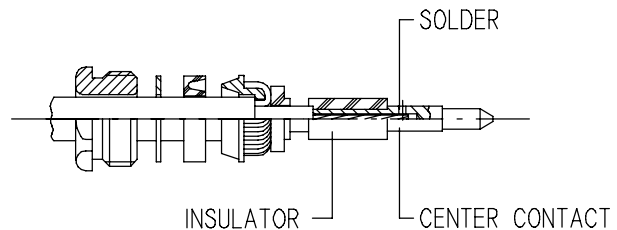

- Insert contact/cable assembly into body assy.
- Slide bushing, braid clamp, gasket and washer into body assy.
- Screw clamp nut in place and tighten using 45 to 55 inch. pound torque (5 to 6 m.N).

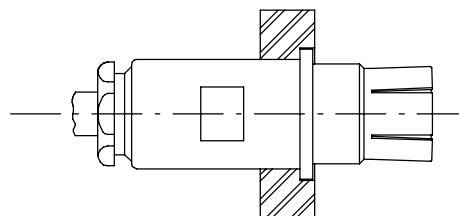

WIRING INSTRUCTIONS C

- Trim cable to dimensions shown.

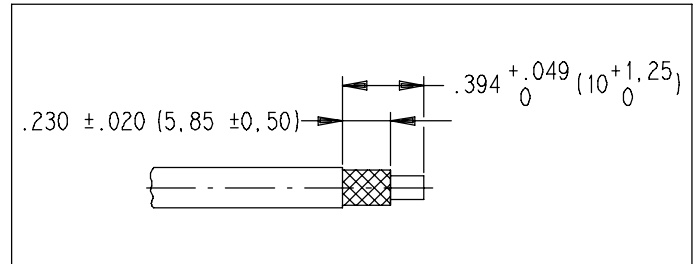

- Slide nut, washer and gasket over outer jacket.
- Next slide braid clamp until it butts up against outer jacket

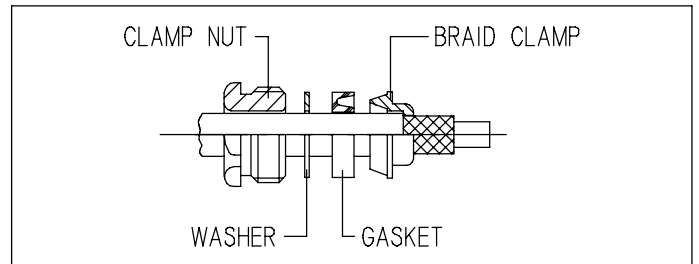

- Comb braid until all strands are straight.
- Next fold braid back over braid clamp as shown.

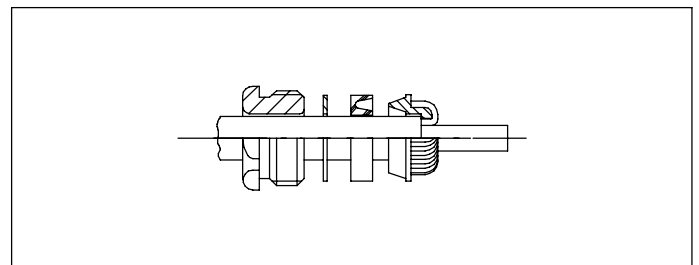

- Slide bushing over dielectric until it stops against braid.
- Trim dielectric as shown.
- Trim inner conductor to dimension shown

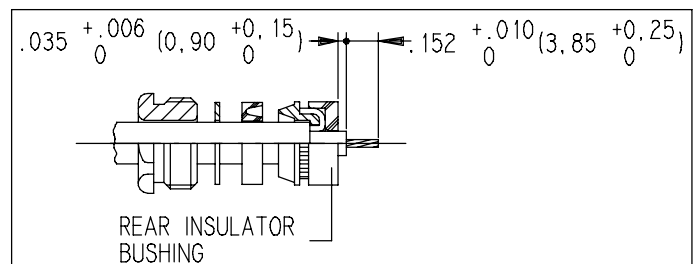

- Assemble insulator and contact over inner conductor until insulator stops against bushing.
- Solder in place as shown.

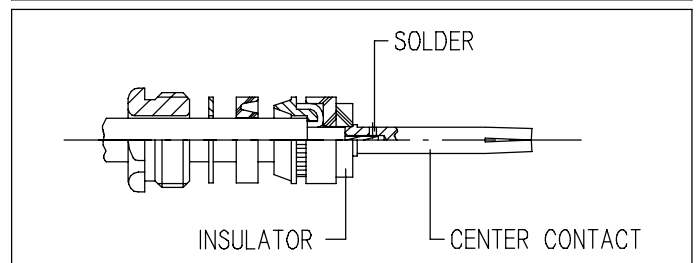

- Insert contact/cable assembly into body assy, slide bushing, braid clamp, gasket and washer into body assy.
- Screw clamp nut in place and tighten using 45 to 55 inch. pounds torque (5 to 6 m.N).

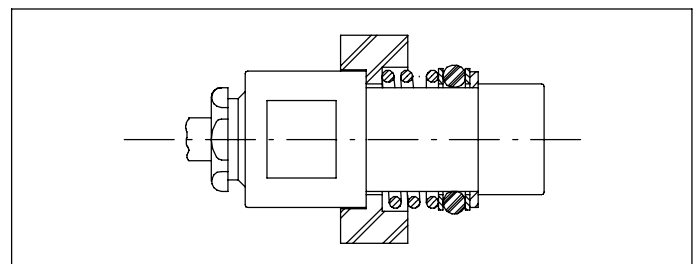

WIRING INSTRUCTIONS D

- Trim cable to dimensions shown.

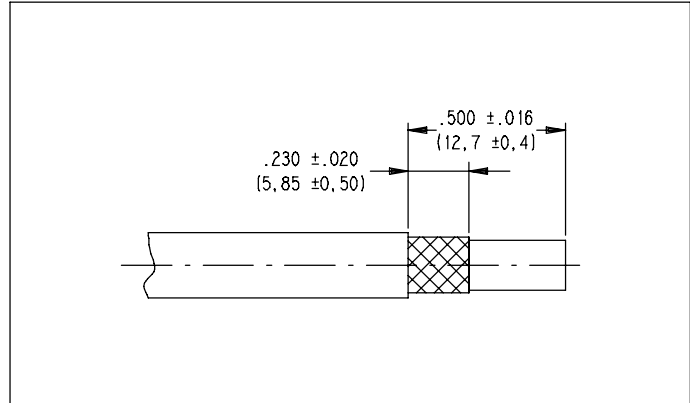

- Slide nut, washer, gasket over outer jacket.
- Next slide braid clamp until it butts up against outer jacket.

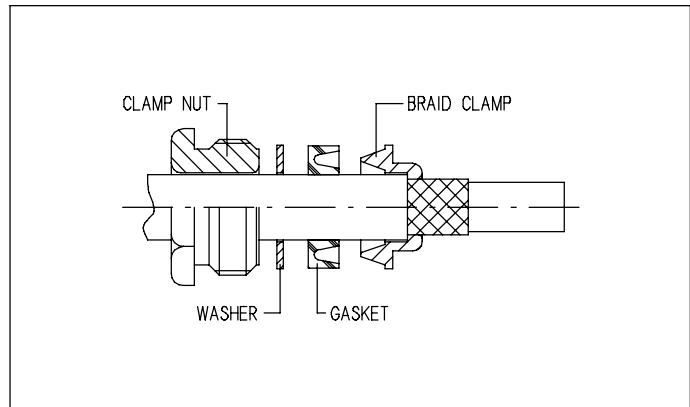

- Comb braid until all strands are straight. next fold braid back over braid clamp as shown.
- Trim dielectric to .300/.330.
- Next trim inner conductor to dimension shown.

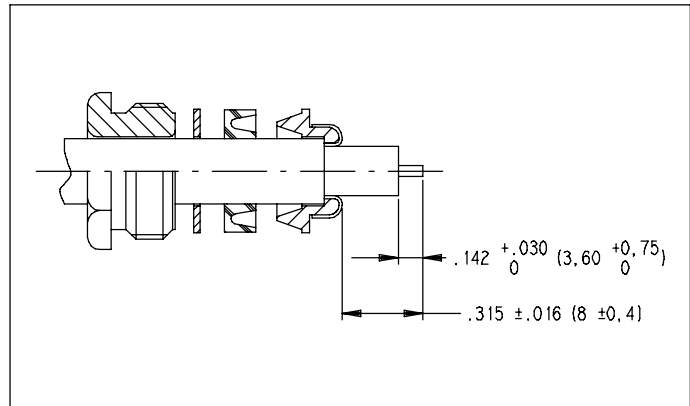

- Insert braid clamp, gasket and washer into body assy (make sure outer jacket butts against braid clamp).
- Tighten nut using 45 to 55 inch pounds torque (5 to 6 m.N).
- Next solder inner conductor to contact.
- Close body assy with clamp nut.

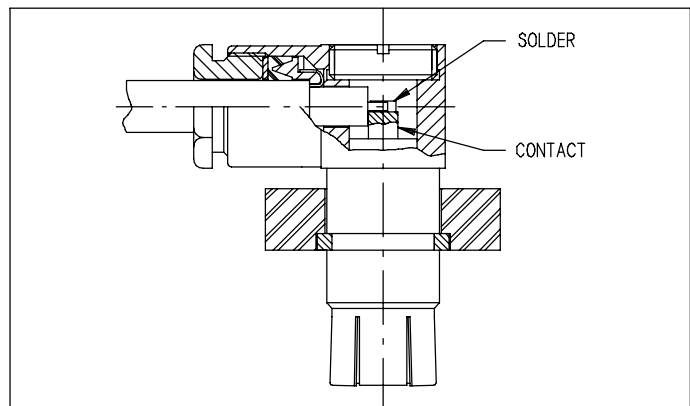

WIRING INSTRUCTIONS E

- Trim outer jacket and dielectric to dimensions shown.

$.100 \pm .010$
(2,50 \pm 0,25)

$.177 \pm .010$
(4,50 \pm 0,25)

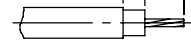

- Slide center contact over inner conductor while conforming to the O2 dimension requirement.
- Next solder as shown.

$.020 \pm .002$
(0,50 \pm 0,05)

$.126 \begin{smallmatrix} +.020 \\ 0 \end{smallmatrix}$ (3,20 $\begin{smallmatrix} +0,50 \\ 0 \end{smallmatrix}$)

CENTER CONTACT

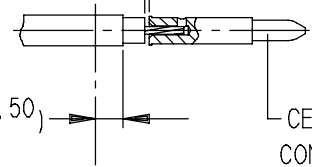

- Insert cable/center contact assembly into body assy while conforming to .125 dimension.
- Next solder outer conductor to body assy.

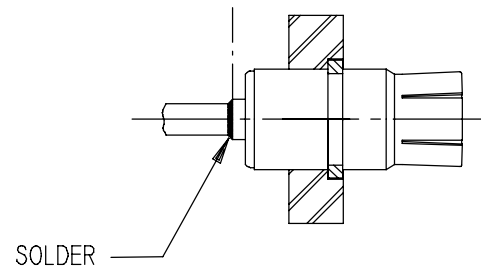

WIRING INSTRUCTIONS G

- Strip cable jacket to dimensions shown and remove band between braids for fileca 1763/94 and 1703/93 wire

CONTACT	A mm (inch)	B mm (inch)
620 108 620 108 001	$8^{0}_{-0.5}$ (.31/.29)	$26^{0}_{-0.5}$ (1.02/1.00)
620 109 620 109 001	$6^{0}_{-0.5}$ (.24/.22)	$16^{0}_{-0.5}$ (.63/.61)
620 117, 620 145 620 147, 620 148	9 ± 0.25 (.36/.34)	30 ± 0.25 (1.19/1.17)
620 119 102		26 ± 0.25 (1.033/1.014)
620 046	5.50 (.216)	13.50 (.531)

- Slide ferrule and nut over the cable and flare the braid.
- Slide crimp barrel fitted with clamp nut over dielectric and place braid on knurled area.

(Note: for 620 108, 620 108 001, 620 109, 620 109 001, slide first thermoretractable sheath over cable).

- Slide ferrule over braid maintaining a gap (.020 max) between ferrule and clamp nut. crimp ferrule using :

CABLE	CRIMPING TOOL	DIE
ASNE 0406WD FILOTEX 50MFCFB ECS 311201 FILECA 1703/94 RG214 BA 6903A	282 293 M22520/5.01	282 247 M22520/5.61
TIMES AA 5887		M22520/5.29 Hex. A
TIMES AA 5886		M22520/5.61
RG 400, RG 402 FILECA 1703/93		282 246 M22520/5.05
ECS 310801		M22520/5.21

- Slide dielectric washer over center conductor then center contact and crimp with :

CABLE	CRIMPING TOOL	POSITIONER/ TURRET
ASNE 0406WD ECS 311201 RG 214 BA 6903A	282 291 M22520/1.01 SELECTOR 8	282 997 M22520/1.13 GREEN
TIMES AA 5887 FILOTEX 50MFCFB FILECA 1703/94		282 997 M22520/1.13 RED
TIMES AA5886		282 972 (M22520/1.02) BLUE
RG400 FILECA 1703/93	M22520/1.01 SELECTOR 7	282 997 (M22520/1.13) RED
ECS 310801	282 296 DANIELS 300 BT	282 586 001
RG 142	Solder	

- Introduce the cable into the outer contact, screw and tighten the clamp nut with 10-15 in. lbs torque (1.1 to 1.7 m.N).

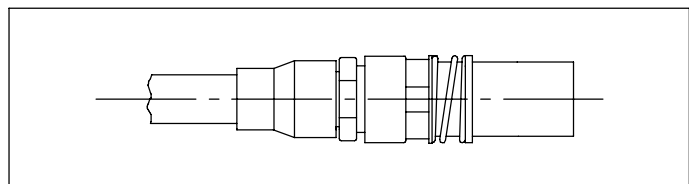
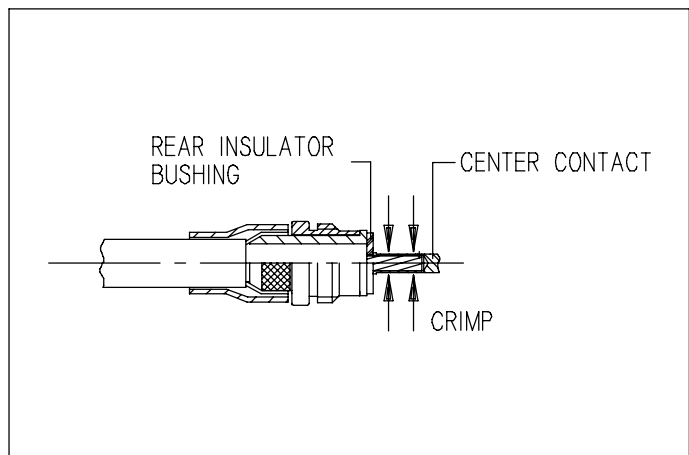
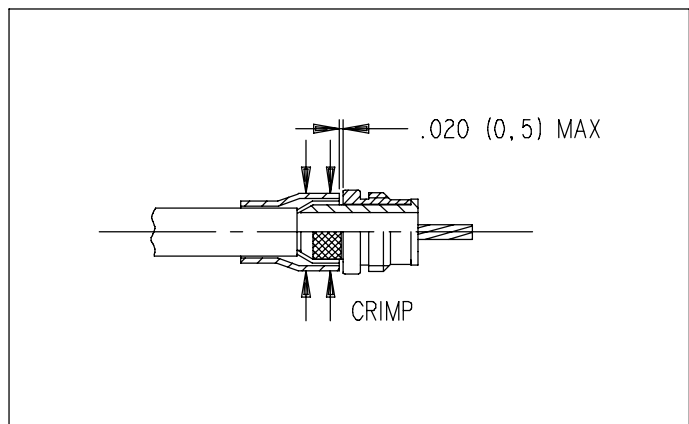
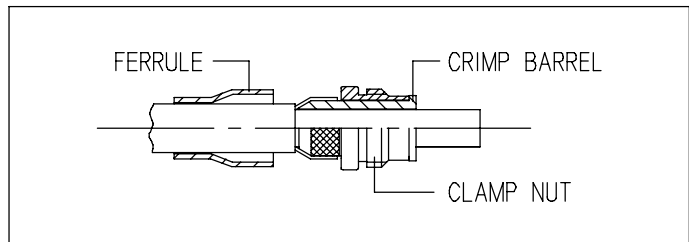
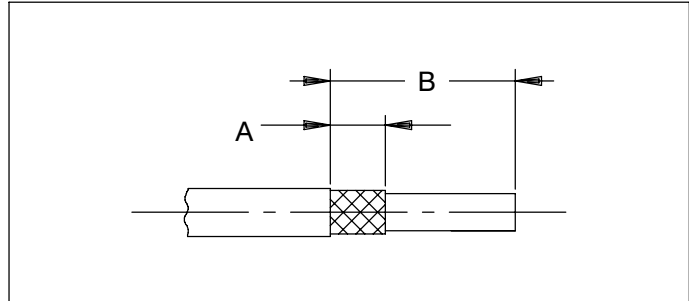

WIRING INSTRUCTIONS H

- Trim cable jacket to length indicated :

CABLE	A ± .010 (0.25)	B ± .010 (0.25)
FC 11Z	.340 (8.6)	.235 (6)
FC 14Z	.340 (8.6)	.215 (5.5)

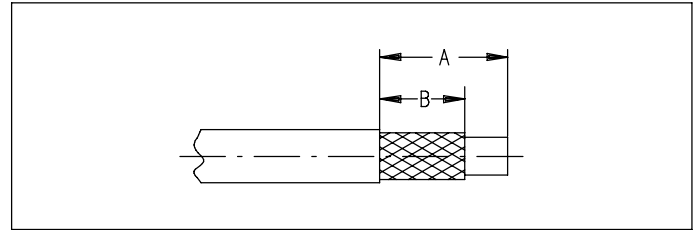

- Slide ferrule over the braid.
- Fold back braid. strip inner conductor to dimension shown.

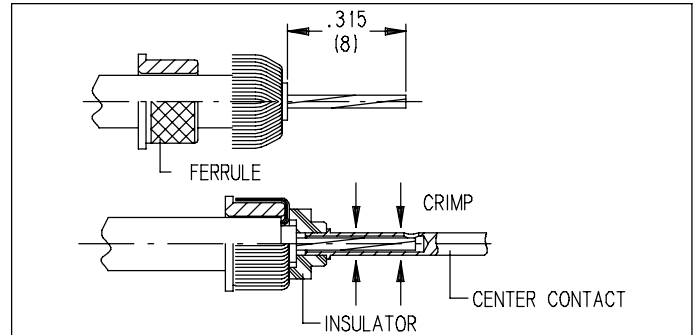

- Introduce inner conductor into center contact sub-assembly.
- Then crimp center contact using :
 tool : **282 281** (M22520/2.01),
 selector : 7 for FC 11Z, FC 14Z,
 positioner : **282 587**.
- Slide ferrule until butting. Fold back braid over ferrule as shown

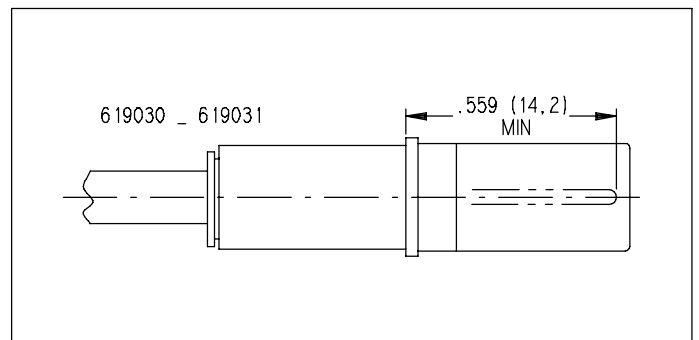

- Introduce this sub assembly into outer contact and push the ferrule until butting.

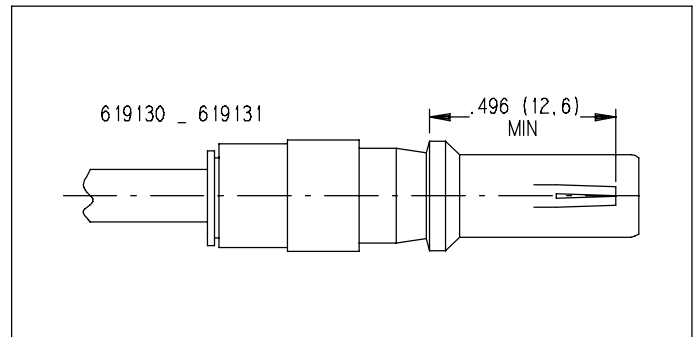

- Crimp outer contact in the indicated area using :
 tool : **282 293** (M22520/5.01),
 die : M22520/5-104 (DANIELS y793).
- During crimping operation push on the ferrule

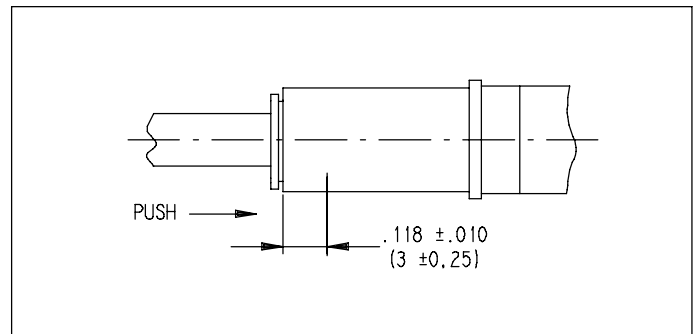

WIRING INSTRUCTIONS J

- Strip cable jacket to dimensions shown.

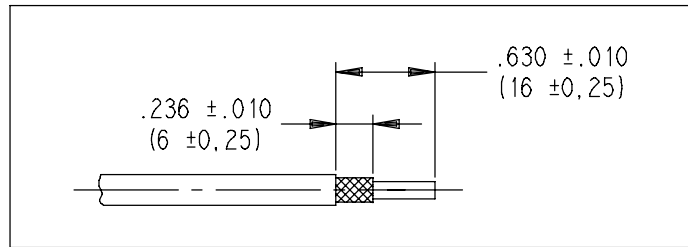

- Slide nut and ferrule over the cable and flare the braid. slide crimp barrel over dielectric and place braid on knurled area. slide ferrule over braid and crimp using :

CABLE	CRIMPING TOOL	DIE
RG 142 TIMES AA 6343 ECS 3C142B RG 400 ASNE 0293XF	282 293 (M22520/5.01)	282 246 (M22520/5.05) Hex A or 282 236 (M22520/5.45) Hex B
TIMES AA 5888 ECS 311601		M22520/5.13 Hex A

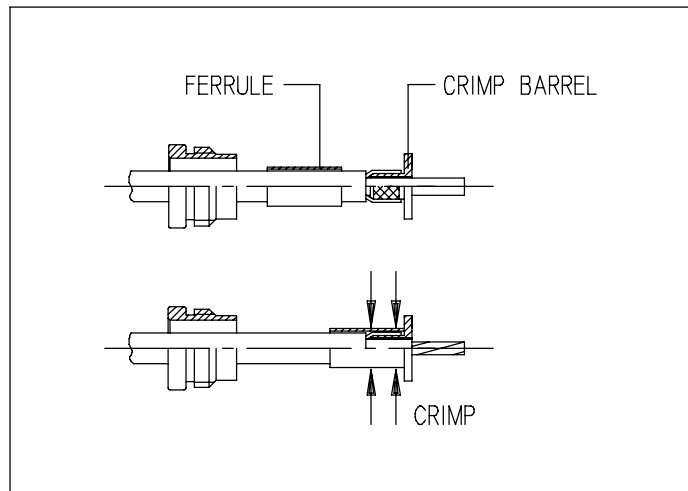

- Then trim dielectric.

- Slide dielectric washer over center conductor then center contact.

- Crimp center contact using :

CABLE	CRIMPING TOOL	POSITIONER/ TURRET
RG 142 TIMES AAG 343 ECS 3C 142B RG400 ASHE 0293XF	282 291 (M22520/1.01) SELECTOR 7	282 997 (M22520/1.13) GREEN
TIMES AA5888 ECS 311301		

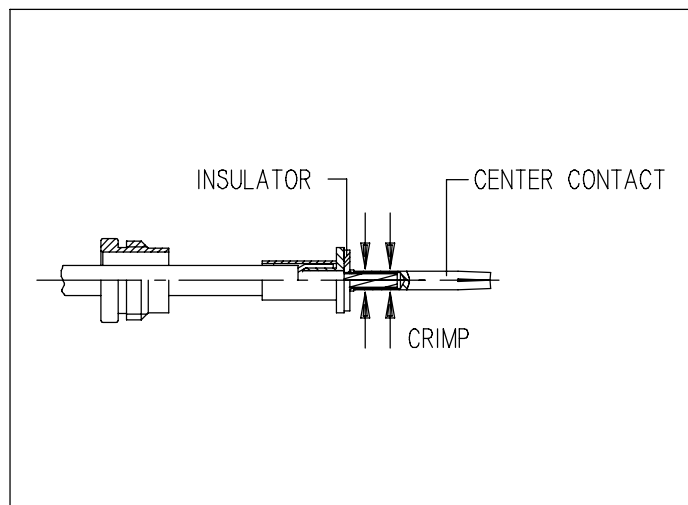

- Introduce the cable into outer contact, screw and tighten the clamp nut with 10-15 in.Lbs torque (1.1 to 1.7 m.N).

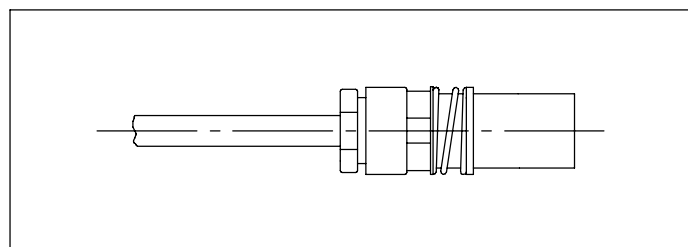

WIRING INSTRUCTIONS L

- Put the sealing boot and the shield termination ferrule over the coax cable. Remove $.354 \pm .010$ on the cable jacket.

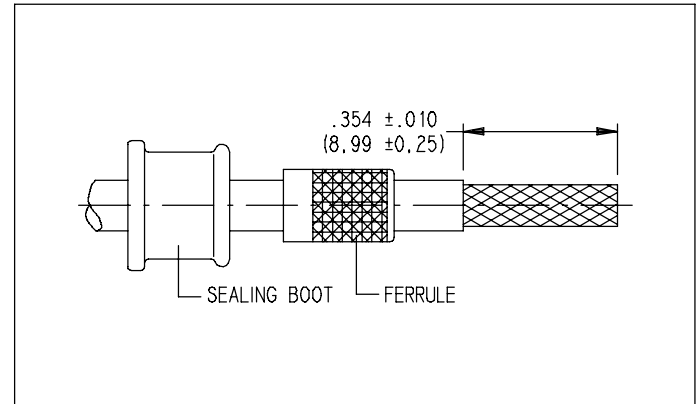

- Fold the round braid and the flat braid back over the cable jacket.
- If necessary separate the strands of the flat braid and make the strands straight before you fold them back.
- Remove $.260 \pm .010$ of the dielectric.

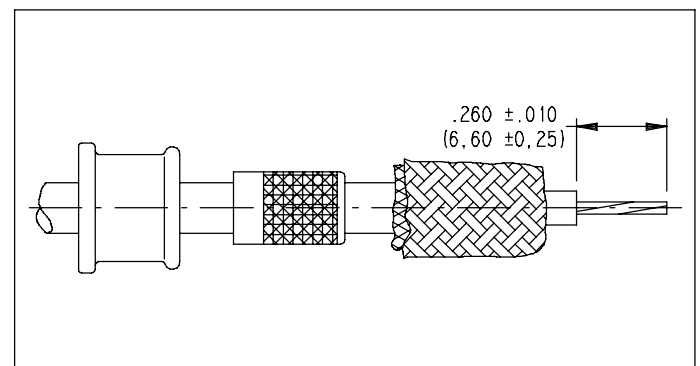

- Put the rear insulator bushing over the center conductor.
- Push the rear insulation bushing until it touches the shield braid.
- Put the center contact over the center conductor and push until it touches the insulator bushing.
- Make sure that you can see the conductor strands through the inspection hole in the center contact.
- Crimp with :
 - tool : **282 281** (M22520/2.01),
 - positioner : **282 550** (DANIELS K345),
 - selector : 5 for FC 11Z cable,
6 for FC 14Z cable,
6 for RAYCHEM 5021K1011.

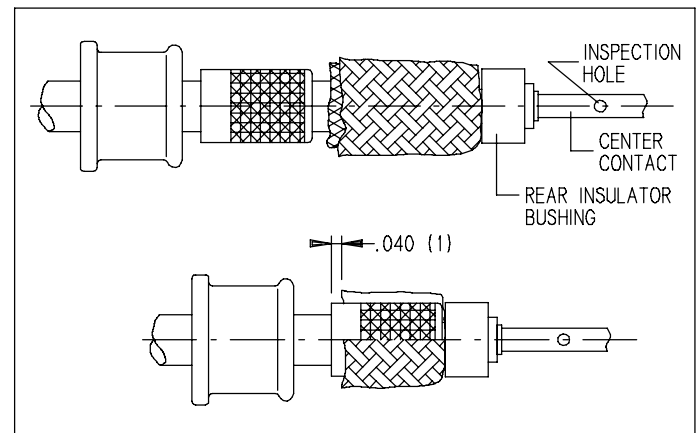

- Push the shield termination ferrule forward until it touches the shield braids that touch the insulator bushing.
- Put the shield braids symmetrically around the shield termination ferrule and cut the shield braids at .040 from the edge of the shield termination ferrule. push the cable and center contact assembly into the outer contact assembly until it stops.
- Crimp the outer contact in the area shown.
- Crimp with :
 - tool : **282 293** (M22520/5.01),
 - die : **282 236** (M22520/5-45) Hex B.

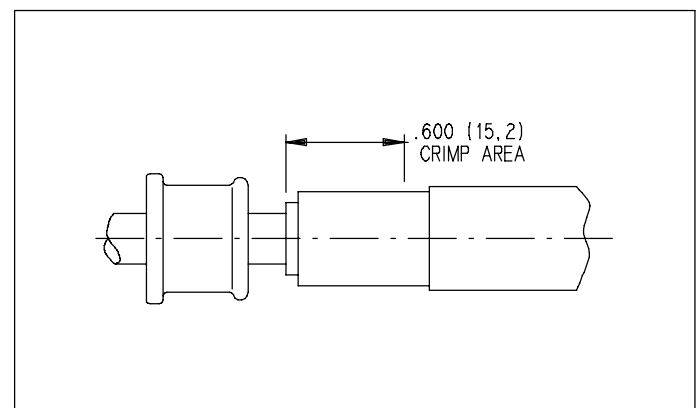

WIRING INSTRUCTIONS M

- Slide ferrule over outer jacket and trim cable to dimension shown.

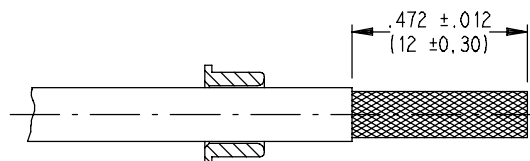

- Roll up braids, cut dummy conductors and trim conductors to dimensions shown.

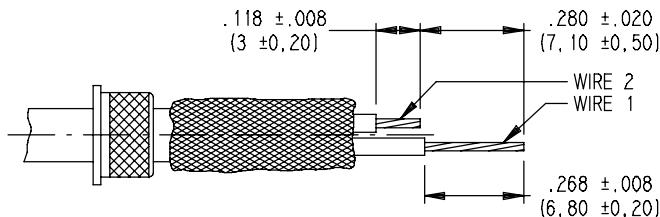

- Slide washer over the 2 conductors until it butts against braids.
- Introduce conductor No 1 into center contact.
- Introduce conductor No 2 into intermediate ferrule.
- Crimp using :
 tool : **282 293** (M22520/5-01),
 die : M22520/5-104 (DANIELS Y793).
- Make sure that conductor No 2 is under up die.

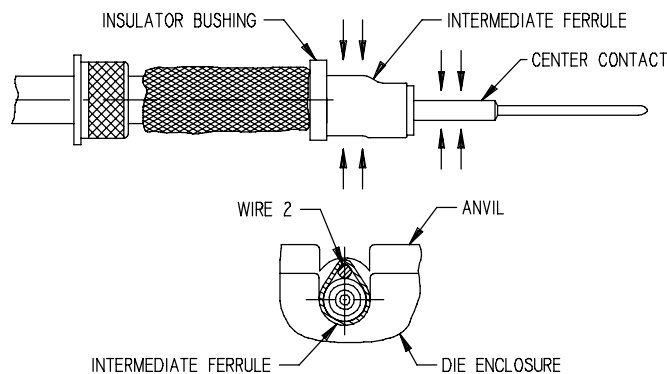

- Slide ferrule under braids until it butts against washer.

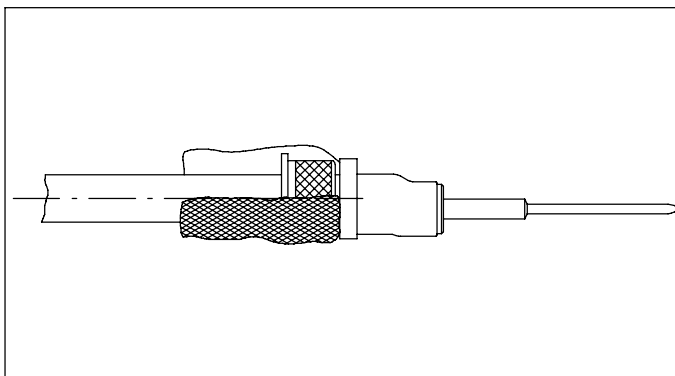

WIRING INSTRUCTIONS **M** (continued)

- Insert center contact sub assembly into outer body.
- Check center contact position before crimping and crimp in the area shown using :
 tool : M22520/5-01,
 die : M22520/5-104

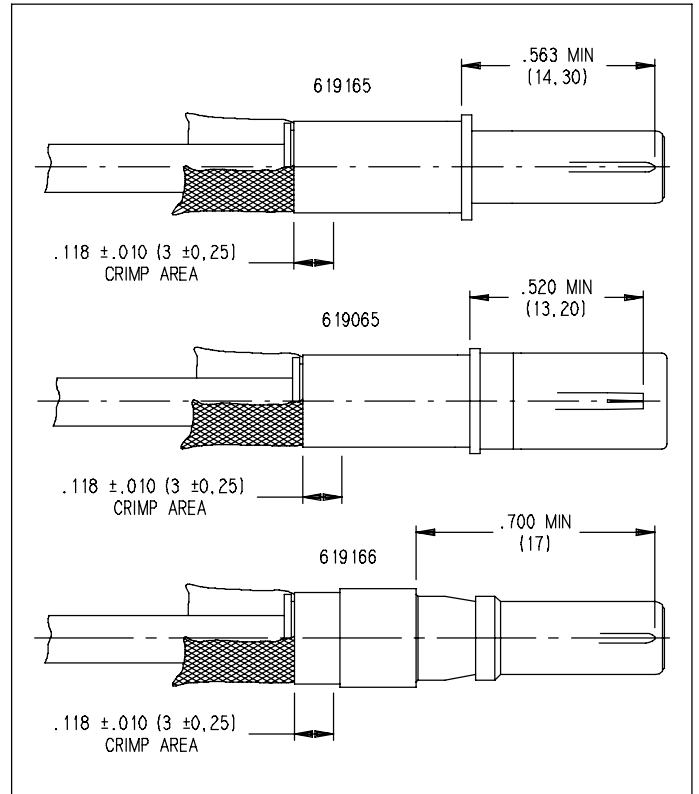

- After crimping cut braids close to outer body

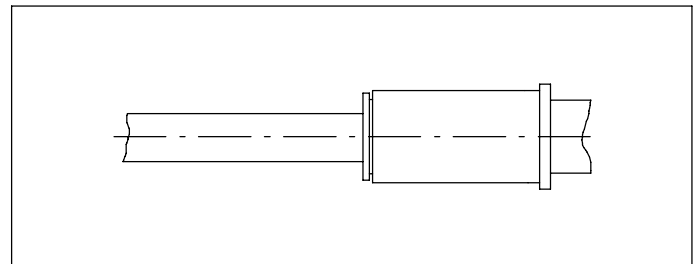

WIRING INSTRUCTIONS P

- Slide ferrule over outer jacket. next trim outer jacket, braid and dielectric to dimensions shown.

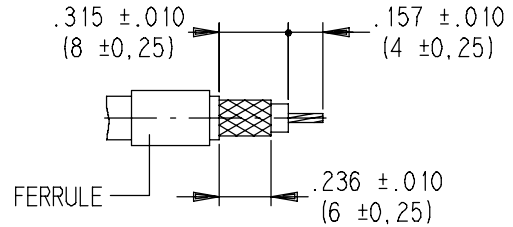

- Slide center contact over inner conductor and crimp by using :

- tool : **282 281** (M22520/2.01),
- selector : 6 for RG 58 and RG 223,
8 for RG 141, RG 142 and RG 400
- positioner : **282 550** (DANIELS K345).

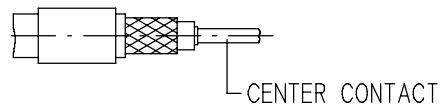

- Flare braid and slide outer contact underneath.

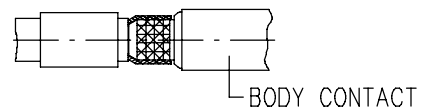

- Slide ferrule over braid and crimp ferrule over outer contact by using :

- tool : **282 293** (M22520/5.01),
- die : **282 246** (M22520/5.05)
- Hex B .177 on flats.

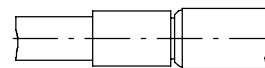

WIRING INSTRUCTIONS R

- Trim outer jacket to dimensions shown

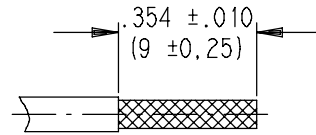

- Slide ferrule over braid until it batts up against outer jacket.
- Comb braid until all strands are straight.
- Next fold braid back over ferrule and cut it to dimension shown.
- Next trim dielectric as shown.

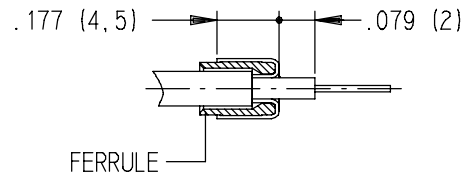

- Slide bushing over dielectric.
- Next slide center contact over inner conductor and crimp with :

tool : **282 281** (M22520/2.01),
 positioner : **282 550** (DANIELS K345),
 selector : 6 for RG 179, RG 316, RG 178,
 KX 21 and KX 22
 selector : 7 for RD 316

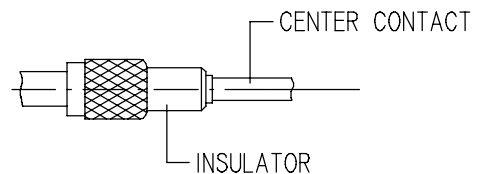

- Insert contact/cable assembly into outer contact and crimp with :

tool : **282 293** (M22520/5.01),
 die : **282 246** (M22520/5.05)
 Hex B .177 on flats.

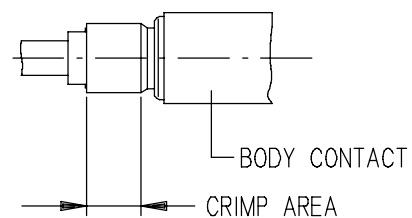

WIRING INSTRUCTIONS S

- Trim cable as shown.

- Slide ferrule over sheath flare the braid.
- Insert center conductor into center contact and crimp using :

tool : **282 281** (M22520/2.01),
positioner : **282 555** (DANIELS K370)
selector : 1 for RG 179, ASNE 0639XY
selector : 2 for RG 316, ASNE 0752WS and
ASNE 0632WK.

- Push cable assembly into contact body and fold braid over barrel.

- Slide ferrule to .020 of shoulder barrel and crimp using :
tool : **282 292** (M22520/4.01),
positioner : **282 556**

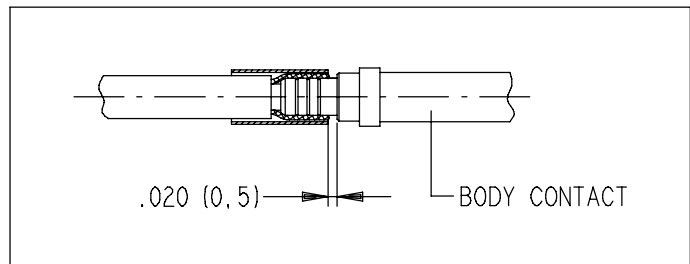
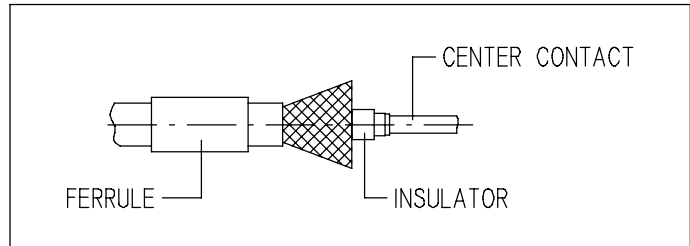
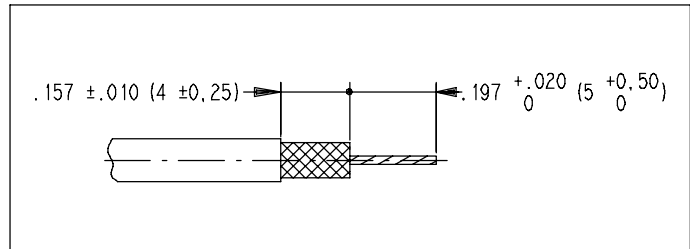

WIRING INSTRUCTIONS T

- Trim cable as shown

- Slide ferrule over sheath flare the braid.
- Insert center conductor into center contact and crimp using :

tool : **282 281** (M22520/2.01),
positioner : **282 555** (DANIELS K370)
selector : 1 for RG 178, ASNE 0633WG

- Push cable assembly into contact body and fold braid over barrel.

- Slide ferrule to .020 of shoulder barrel and crimp ferrule, turn the contact of about 45 degrees and crimp the ferrule a second time using :

tool : **282 292** (M22520/4.01),
positioner : **282 556**

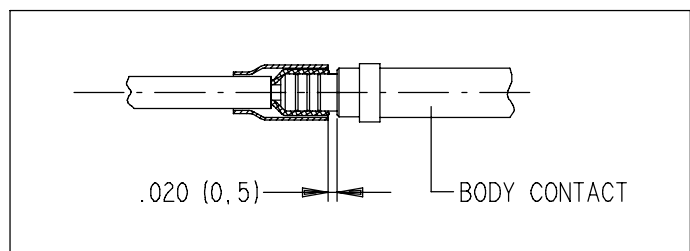
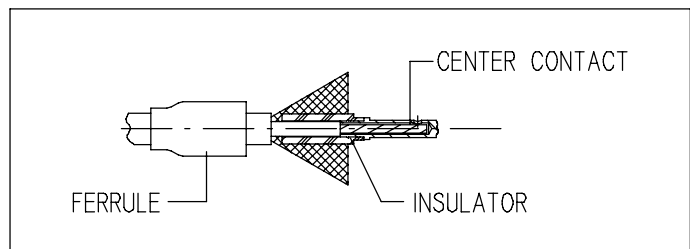
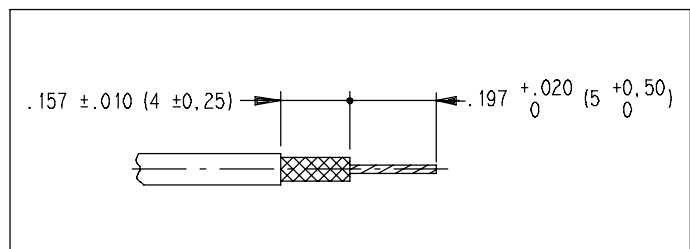

WIRING INSTRUCTIONS U

- For environmental application, before stripping, slide sealing booth over cable.
- For non environmental pin contacts (**670 150, 670 151, 618 160** and **618 161**), slide alignment boot over cable before stripping.
- Trim cable jacket to length indicated.

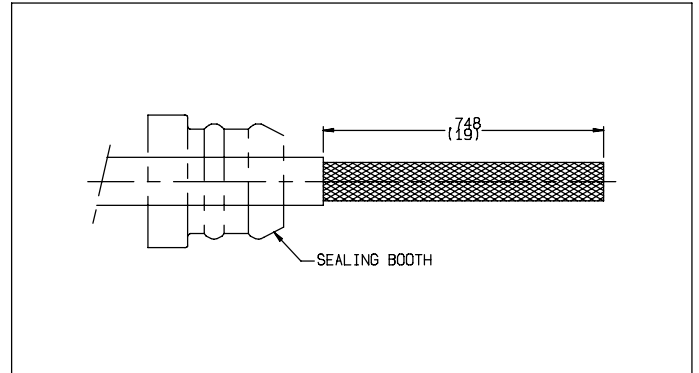

- Slide the ferrule over the cable.
- Cut the high immunity ribbon if any fold back braid or braids over the ferrule as indicated.
- Cut braid or braids as shown
- Cut rod fillers
- Strip the two inner conductors

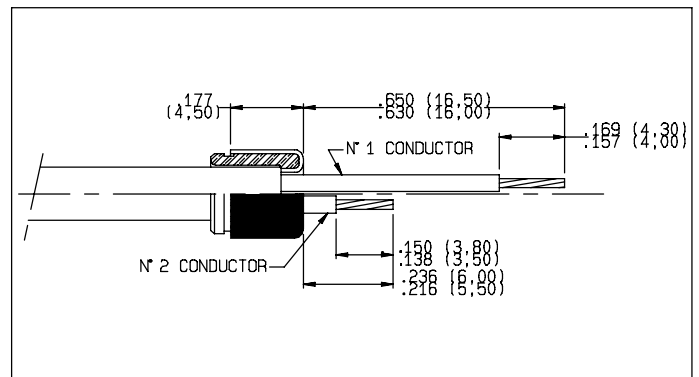

- Introduce the No.2 conductor into the intermediate contact crimp pot crimp the intermediate contact crimp pot :
 tool : **282 281** (M22520/2-01)
 positioner : **282 574**
 selector : 5

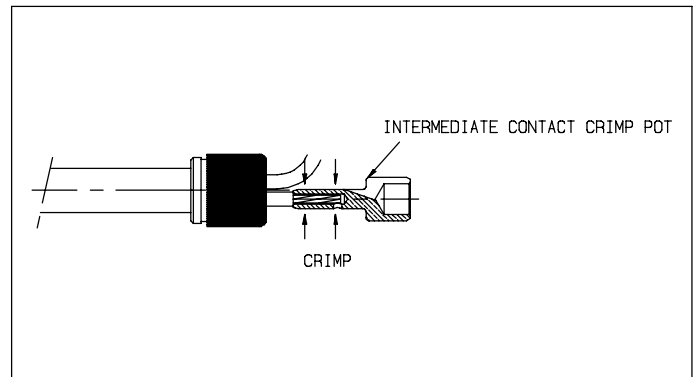

- Put the No.1 cable in the slot of the intermediate contact crimp pot slide the center contact over the conductor crimp the center contact :
 tool : **282 281** (M22520/2-01)
 Positioner : **282 576**
 Selector : 5

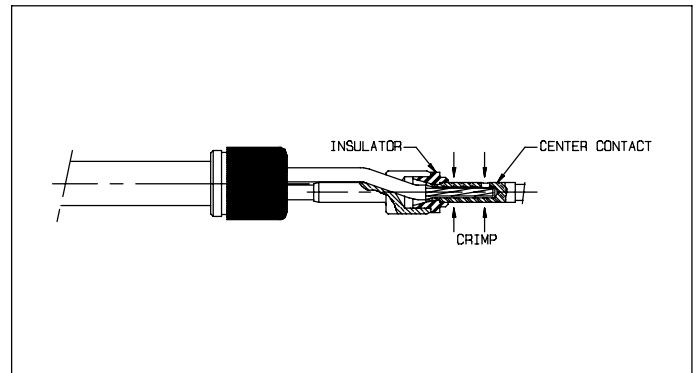

WIRING INSTRUCTIONS **U** (continued)

- Install the rear insulator
- Introduce this cable assembly into the contact body sub-assembly

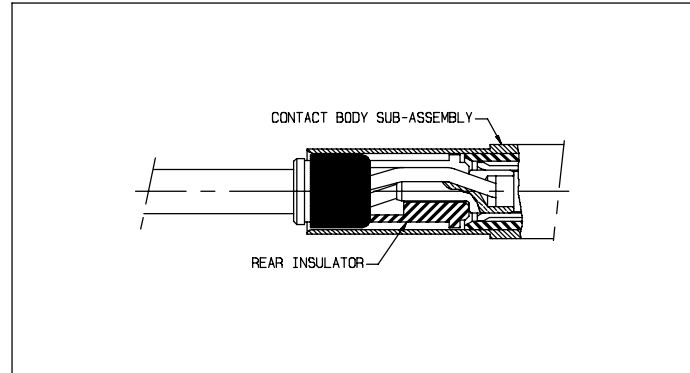

- Crimp the outer contact body in the indicated crimping area :

tool : **282 293** (M22520/5-01)

Die : **282 236** (M22520/5-45)

Hex die closure 8 (.216/flats)

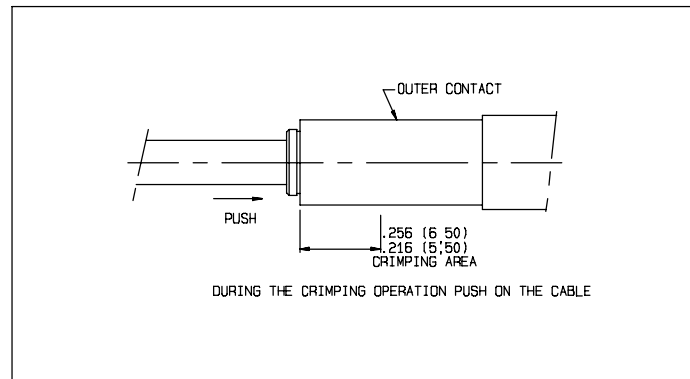

DURING THE CRIMPING OPERATION PUSH ON THE CABLE

INSPECTION DIMENSION AFTER ASSEMBLY

CONNECTOR	CONTACT	DIMENSIONS	
		A MAX	B MAX
MIL-C-81659 DSX	616 095 001		.097 (2,46)
	616 096 004		.152 (3,88)
	616 195 001	.078 (1,97)	
	616 196 003 616 196 004	.033 (0,81)	

A : distance between the end of outer pin contact and the end of the center pin contact

B : distance between the end of outer socket contact and the end of intermediate pin contact

WIRING INSTRUCTIONS W

- Strip the cable at dimension shown.

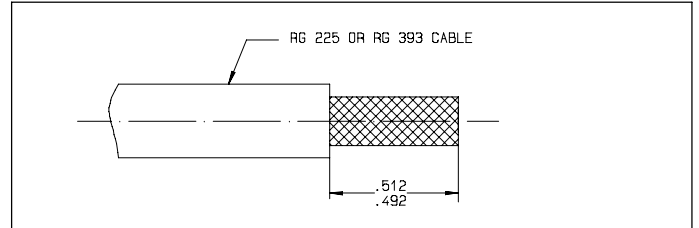

- Slide clamp nut, ring gland, seal and braid clamp over the cable.
- Comb braid until all strands are straight.
- Cut braid to dimension shown.

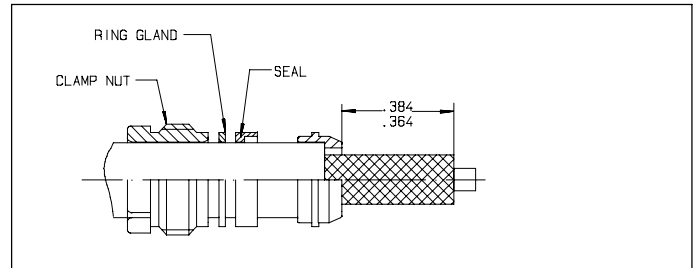

- Fold back braid over braid clamp.
- Strip and trim inner conductor at dimension shown.

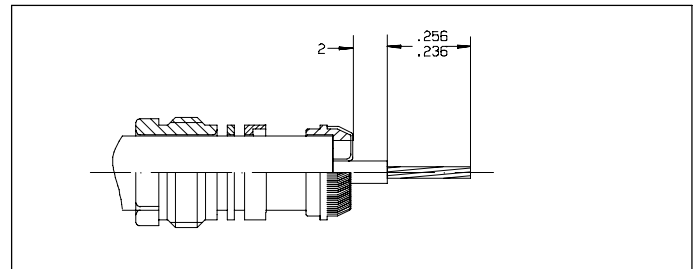

- Place center contact over inner conductor until stops against dielectric.
- Solder center contact.

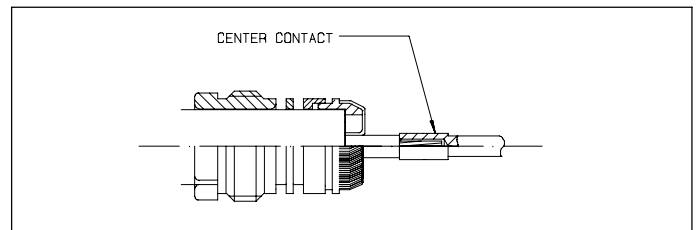

Mounting of the size 1 coax contacts in the connector

The C4 insert is composed of :

- 1 front plate
- 1 rear plate
- the insert retention plate

Design of rear plate

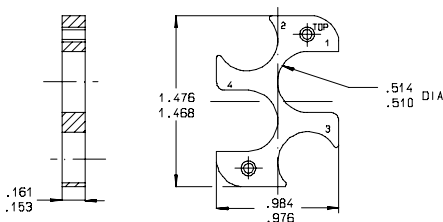

Insert the front plate in the connector. Then, fix it with the insert retention plates;

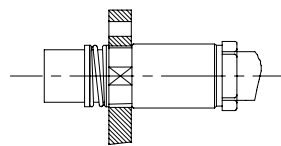

Locate the four coaxial contacts in the corresponding holes of rear plate (the removal of circlips, washer and spring is not necessary).

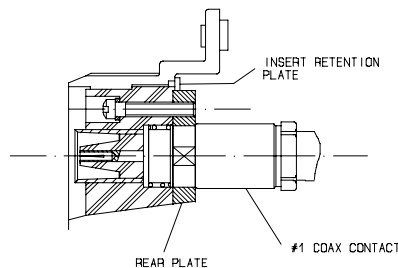
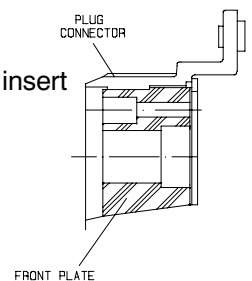

Then, the assembly (contacts and rear plates) is inserted in the connector and maintained by the two attachment screws.

WIRING INSTRUCTIONS Y

- Strip the cable at dimension shown.

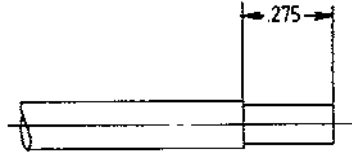

- Slide the nut over the cable.
- Introduce the solder ferrule on the dielectric until butting on the cable.
- Solder the ferrule with a 250W max tool then trim dielectric

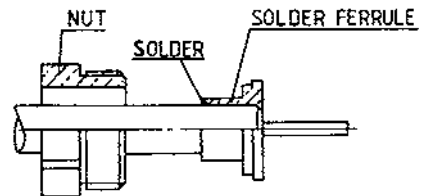

- Slide dielectric washer on the center conductor then center contact.
- Solder the center contact with a 250W max tool.

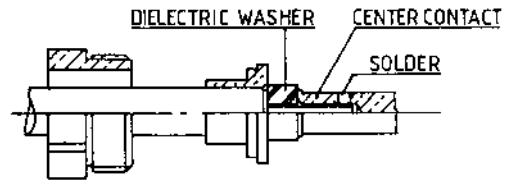

- Introduce the cable assembly into the outer contact screw and tighten the nut.

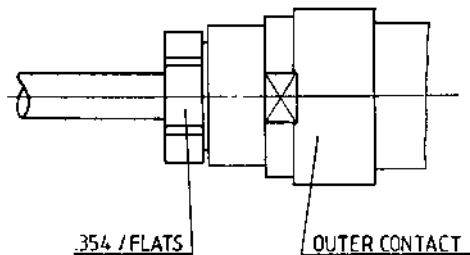

CRIMPING TOOLS

PART NUMBER	CRIMPING TOOLS
282 291	M22520/1.01
282 281	M22520/2.01
282 292	M22520/4.01
282 293	M22520/5.01
/	M22520/23.01
/	M22520/31.01



POSITIONERS

PART NUMBER	MIL SPEC P/N
282 972	M22520/1.02
282 579	M22520/1.11
282 997	M22520/1.13
282 971	M22520/2.08
282 970	M22520/2.23
/	M22520/23.09
282 550 (DANIELS K345)	/
282 555 (DANIELS K370)	/
282 556	/
282 587	/
282 588	/





DIES

PART NUMBER	MIL SPEC P/N
282 246	M22520/5.05
/	M22520/5.13
/	M22520/5.29
282 236	M22520/5.45
282 247	M22520/5.61
/	M22520/23.02
/	M22520/5.104



PART NUMBER	MIL SPEC P/N	DESCRIPTION
282 885	M81969/1.01	ins/ext tool for rear release rear removable size 22 contacts (crimp version)
282 886	M81969/1.02	ins/ext tool for rear release rear removable size 20 contacts (crimp version)
282 546	M81969/1.03	ins/ext tool for rear release rear removable size 16 contacts (crimp version)
282 549 004	M81969/14.04	extraction tool for rear release rear removable size 12 contacts
/	M81969/19.02	extraction tool for front release rear removable size 12 power contacts
/	M81969/19.03	extraction tool for front release rear removable size 8 contacts
282 946	M81969/28.01	ins/ext tool for rear release rear removable size 5 coaxial contacts (metallic)
282 549 001	M81969/28.03	extraction tool for rear release rear removable size 8 contacts
282 500	/	ins/ext tool for front release front removable size 22 contacts
282 503	/	ins/ext tool for front release front removable size 20 contacts
282 504	/	ins/ext tool for front release front removable size 16 contacts
282 547	/	extraction tool for rear release rear removable size 12 contacts, crimp version
282 548	/	extraction tool for rear release rear removable size 5 coaxial contacts
282 549 001	/	extraction tool for rear release rear removable size 8 contacts
282 549 005	/	ins/ext tool for front release front removable size 12 contacts
282 549 009	/	extraction tool for front release front removable size 8 triaxial contacts
282 549 011	/	insertion tool for front release front removable size 8 triaxial contacts, solder tail version
282 549 012	/	extraction tool for front release rear removable size 8 triaxial contacts
282 890	/	ins/ext tool for rear release size 22 contacts solder tail and wire wrap terminations
282 892	/	extraction tool for rear release rear removable size 16 coaxial contacts
282 945	/	extraction tool for rear release rear removable size 12 coaxial contacts
282 548	/	extraction tool for rear release rear removable size 5 coaxial contacts (plastic)

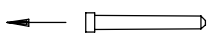
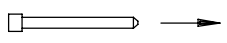
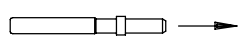

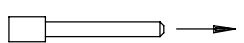
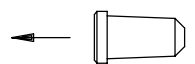
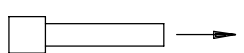
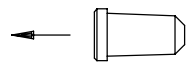
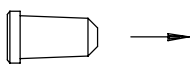
SIZE	CONTACT CAVITY TYPE	VERSION	INS	EXT	COLOR / TYPE	PART NUMBER	FIGURE
22	for pin & socket	non environmental	rear	rear	black	620 920	
		environmental				616 910	
	for socket	non environmental	front	front	Aluminum	620 919	
		non environmental			white	620 926	
20	for pin & socket	non environmental	rear	rear	red	620 921	
		environmental				616 911	
16	for pin & socket	non environmental	rear	rear	blue	620 922	
		environmental				616 912	
12	for pin & socket	non environmental	rear	rear	yellow	620 923	
		environmental				616 913	
	for pin	non environmental	front	front	white	620 936 001	

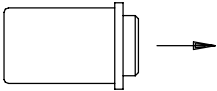
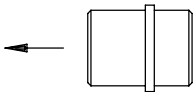
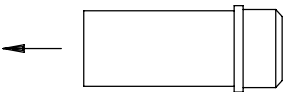
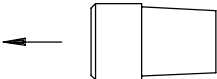
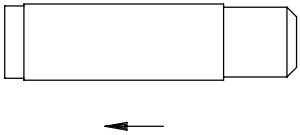



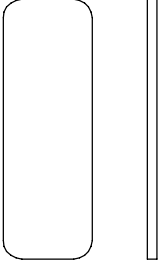
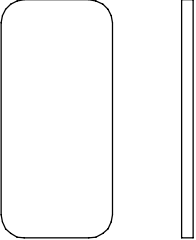
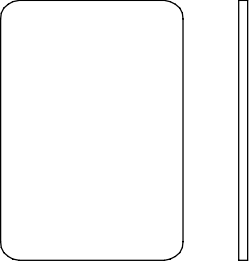
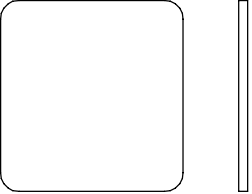

SIZE	CONTACT CAVITY TYPE	VERSION	INS	EXT	COLOR / TYPE	PART NUMBER	FIGURE
12	for pin	non environmental	front	front	nickel	620 936 002	
8	for pin	non environmental	rear	rear	nickel	619 953	
			front	front	nickel	619 952	
	for socket	environmental	rear	rear	nickel	619 950	
	for pin & socket				red	618 915	
5	for pin	non environmental	rear	rear	white	620 924	
	for socket					620 925	
	for pin & socket	front	front	620 937 001			
		environmental	rear	rear	red	925 05 560	



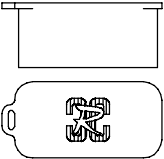

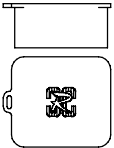
P/N in bold letters indicates sealing plugs made of aluminum alloy nickel plated.

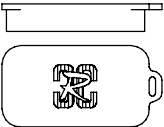
When a cavity shell is not fitted with one of the inserts shown on pages 78 to 87, the cavity shell is fitted with a dummy insert. Dummy inserts are made of aluminum alloy and are available for each cavity shell in two kind of plating : ALODINE 1200 or nickel

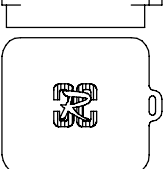
SHELL SIZE	CAVITY	DUMMY INSERT P/N	FIGURE
1	A or B	620 910 (Alodine 1200) 620 913 001 (nickel)	
	C	620 911 (Alodine 1200) 620 913 002 (nickel)	
2 & 3	A or B or D or E	620 912 (Alodine 1200) 620 913 003 (nickel)	
	C or F	620 913 (Alodine 1200) 620 913 004 (nickel)	

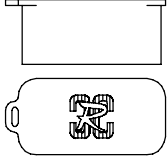
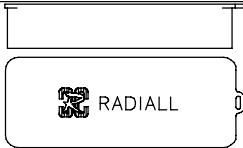
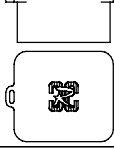
Dust caps are made of thermoplastic. They are available either conductive (black color) or not (red color).

ELECTRICAL CHARACTERISTICS	SHELL TYPE	SHELL SIZE	SHELL CAVITY	PART NUMBER	FIGURE
Conductive	Plug	1	A/B	620 995 003	
			C	620 995 004	
		2 & 3	A/B & D/E	620 995 007	
			C & F	620 995 008	
	Receptacle	1	A/B	620 995 011	
			C	620 995 012	
		2 & 3	A/B & D/E	620 995 015	
			C & F	620 995 016	

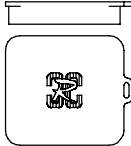
ELECTRICAL CHARACTERISTICS	SHELL TYPE	SHELL SIZE	SHELL CAVITY	PART NUMBER	FIGURE
Non conductive	Plug	1	A/B	620 995 001	
			C	620 995 002	
			SPL	620 995 017	
		2 & 3	A/B & D/E	620 995 005	
			C & F	620 995 006	
	Receptacle	1	A/B	620 995 009	
			C	620 995 010	
			SPL	620 995 018	
		2 & 3	A/B & D/E	620 995 013	
C & F	620 995 014				

The following parts are cavity reducers which allows the use of a size 12 contact in a size 5 cavity. These parts are made of copper alloy and are plated with gold over nickel. Once installed, they cannot be removed.

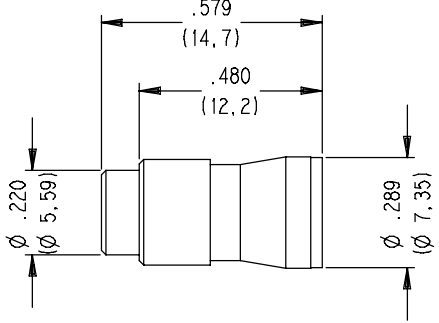
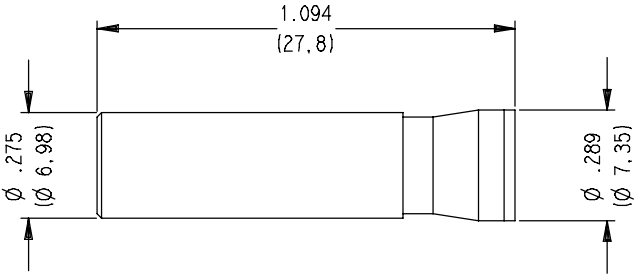
ELECTRICAL CHARACTERISTICS	PART NUMBER	FIGURE
For pin contact	620 940	
For socket contact	620 941	
For pin contact front release / front removable (FR/FR) connector in version G	620 942	

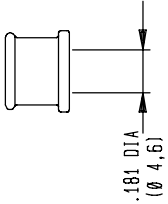
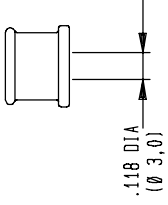
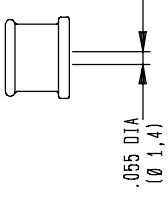

The sealing boots are designed to slide down over the back of the crimped contacts after they have been installed in the connector. The assembly provides bend support and moisture sealing to the contact/cable assembly. Sealing boots are made of fluorosilicone rubber.

CAVITY SIZE	CABLE OUTSIDE DIA.	CABLE	PART NUMBER	FIGURE
5	.197	RG 58 RG 141 RG 142 RG 223 RG 400	925.05.553	
	.150	RG 180 RG 195	925.05.552	
	.102 & .079	RG 179 RG 316 KX 21	925.05.554	

ALIGNMENT BOOTS

Alignment boots are designed to reduce the play at the top of the size 8 pin contacts. Shall be used with rear release/ rear removable size 8 pin contacts.

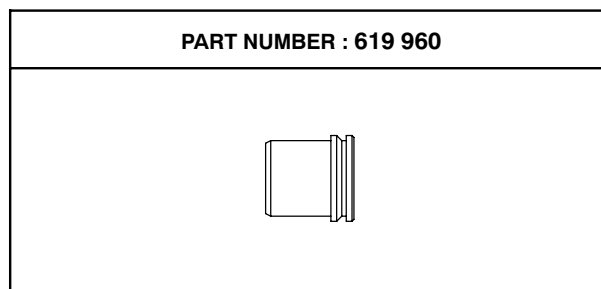

PANEL CUT OUT FOR PLUG SIZE 1, 2 AND 3

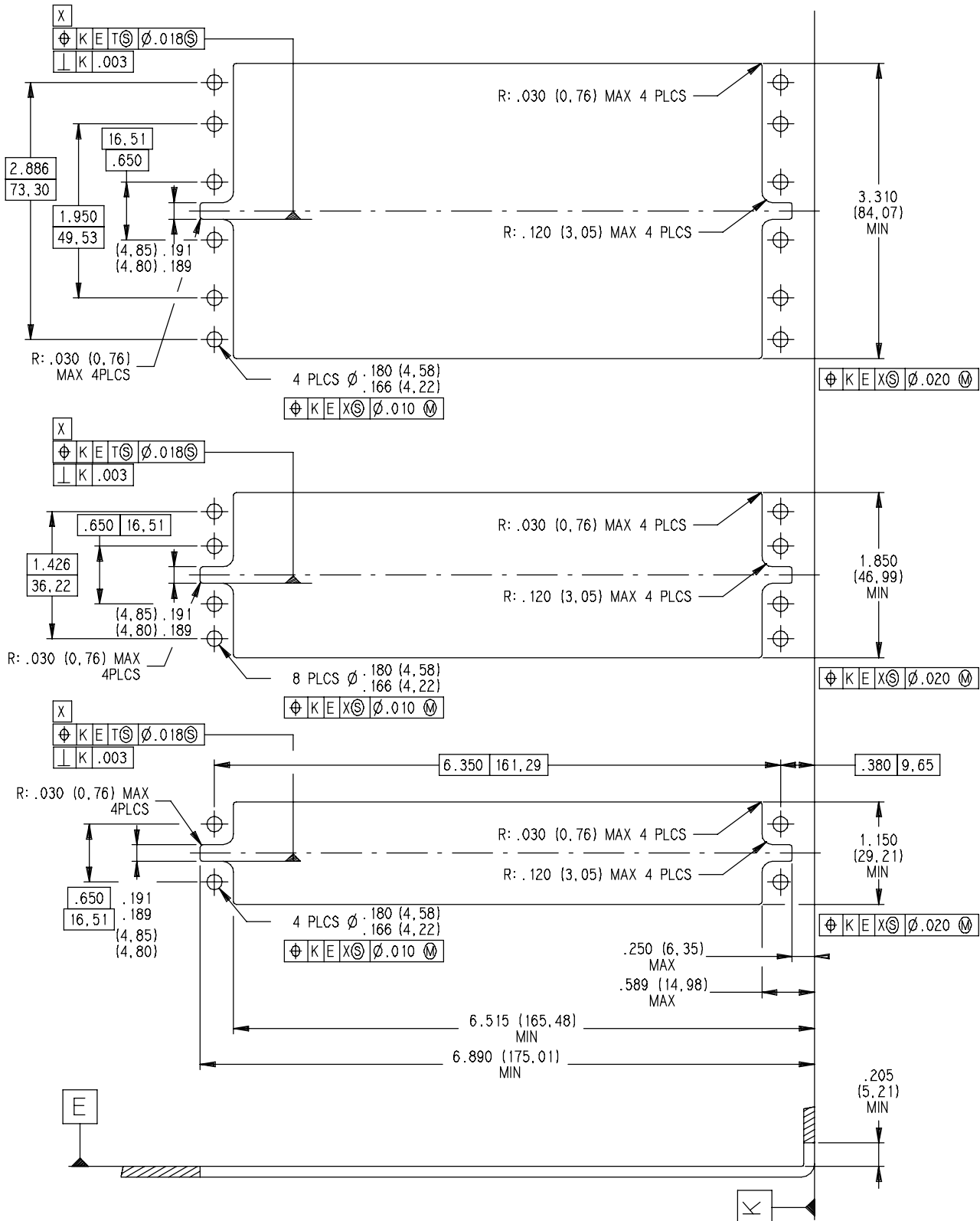

PANEL CUT OUT FOR RECEPTACLE SIZE 1, 2 AND 3

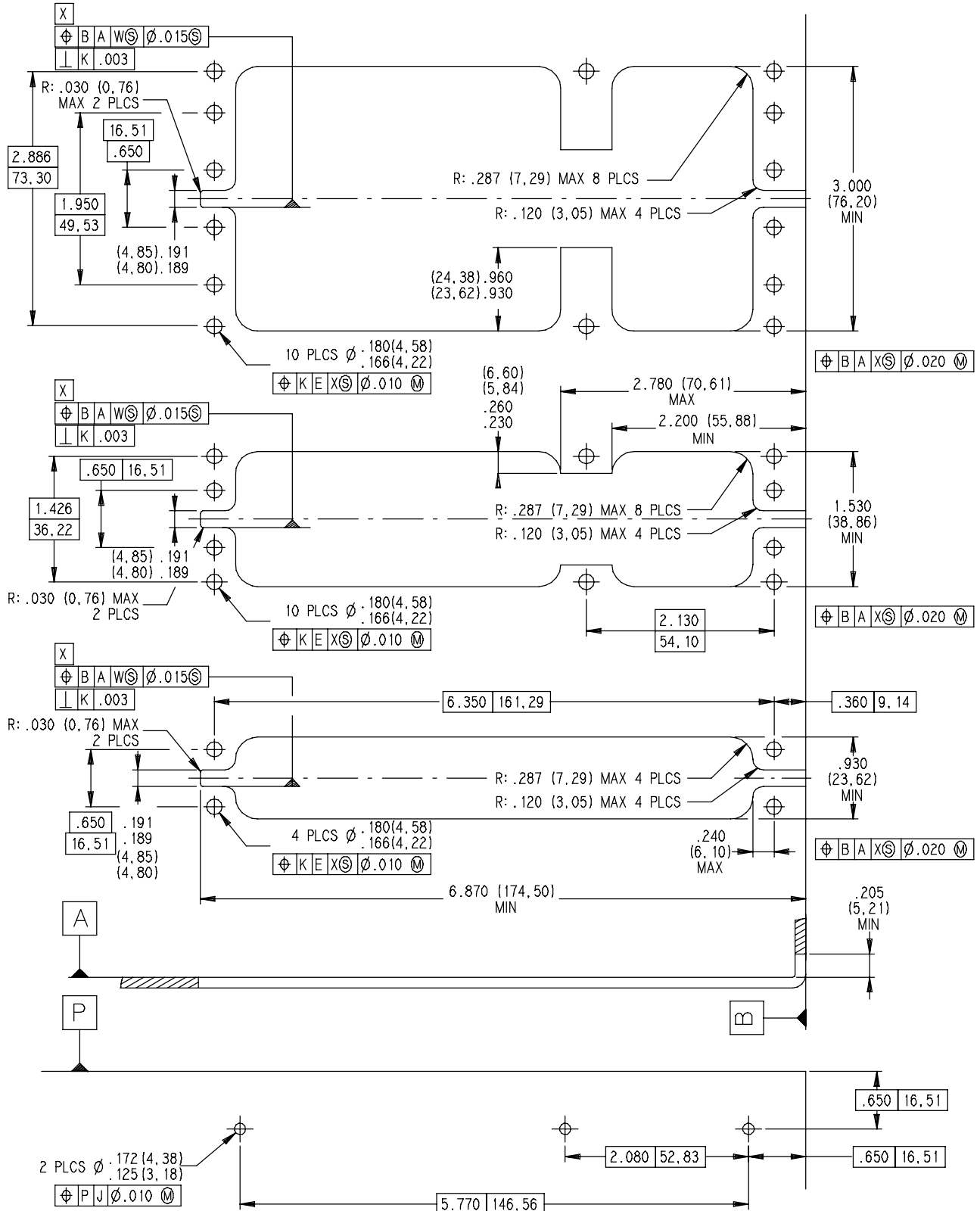

SHELLS

Includes screws, washers, insert retention plate and polarization hardware.

PLUG			RECEPTACLE		
SIZE 1	SIZE 2	SIZE 3	SIZE 1	SIZE 2	SIZE 3
3.88 (110)	4.59 (130)	7.76 (220)	4.59 (130)	4.94 (140)	8.64 (245)

INSERTS

CONTACT ARRANGEMENT DESIGNATION	FOR PLUG SHELL		FOR RECEPTACLE SHELL	
	E TYPE	N TYPE	E TYPE	NOR F TYPE
5C2	0.56 (15.75)	0.45 (12.75)	0.36 (10.25)	0.26 (7.25)
40	0.49 (13.75)	0.40 (11.25)	/	0.25 (8.00)
60	0.65 (18.50)	0.54 (15.25)	0.44 (12.50)	0.33 (9.25)
30T2	0.65 (18.5)	/	/	0.34 (9.50)
150	1.46 (41.50)	1.22 (34.50)	0.98 (27.75)	0.72 (20.50)
121	1.65 (46.75)	/	/	0.85 (24.00)
120T2	1.45 (41.00)	1.20 (34.00)	/	/
71C1/1C71	1.04 (29.50)	0.91 (25.75)	0.63 (18.00)	0.49 (14.00)
60	/	1.77 (50.25)	/	0.93 (26.50)
10T10	/	/	/	/
C4	/	1.04 (29.50)	/	0.70 (19.80)
C2	/	0.97 (27.50)	/	0.48 (13.50)
100	1.08 (30.50)	0.90 (25.50)	0.74 (21)	0.53 (15.00)
85	1.18 (33.50)		/	/
34	1.48 (42.00)	1.24 (35.25)	/	0.67 (19.00)
13C2	1.43 (40.50)	1.19 (33.75)	0.86 (24.50)	0.63 (18.00)
6T6	/	/	/	/

CONTACTS

CONTACT SIZE	PIN	SOCKET
22	4 10 ⁻³ (0.12)	5.3 10 ⁻³ (0.15)
20	7.8 10 ⁻³ (0.22)	14.1 10 ⁻³ (0.40)
16	25.4 10 ⁻³ (0.72)	26.5 10 ⁻³ (0.75)
12	53.0 10 ⁻³ (1.50)	53.0 10 ⁻³ (1.50)
8	619 270 : 0.18 (5) 619 270 : 0.23 (6.5)	

HOW TO ORDER

NSX N 3 P 301 X 00 01

Series _____

Class _____

- N** : non environmental
- E** : environmental, with grommets and compound, plug with O-ring
- H** : environmental, plug without O-ring
- C** : non environmental, with grommets

Shell size _____

- 1** : size 1
- 2** : size 2
- 3** : size 3

Shell style chromatisation _____

- R** : Chromatisation plated receptacle
- P** : Chromatisation plated plug
- F** : Nickel plated receptable
- B** : Nickel plated plug
- M** : Nickel plated plug fitted with grouding spring fingers (see pages 102 to 106)

Insert combination code _____

See combination code (pages 74 to 77) and contacts arrangements (pages 78 to 87)

Contact termination (see note 1) _____

- X** : without contacts
- S** : crimp contacts

Modification code _____

See pages 22 to 24

Polarization code (see note 2) _____

See pages 19 to 21

Impossible part numbers:

NSXH-F
NSXH-R

note 1: Define the signal contact termination code. Power contacts (sizes 8, 12, 16 and 20) will be delivered with crimp termination. If you need to use reduced crimp barrel contacts, use code X and order signal and power contacts separately.
Coax and twinax contacts are to be ordered separately.

note 2: Without polarization code, the connector is delivered with polarization hardware unassembled.
Polarization code 00, the connector is delivered without polarizing hardware.
Polarization code from 01 to 216, the connector is delivered with the polarization hardware assembled as defined by code.

Remark: dust caps conductive on receptacle and non conductive on plug are included in the delivery.

FOR SHELL SIZE 1

CODE	INSERT COMBINATION ON SHELL		
	CAVITY A	CAVITY B	CAVITY C
101	60	60	5C2
102	60	60	blank
103	blank	60	5C2
104	60	blank	5C2
105	blank	blank	5C2
106	60	blank	blank
107	30T2	30T2	40
108	60	60	40

CODE	INSERT COMBINATION ON SHELL		
	CAVITY A	CAVITY B	CAVITY C
109	blank	60	blank
110	60	60	4
111	blank	30T2	40
112	60	4C	5C2
113	60	4C	40
114	60	blank	40
115	blank	blank	blank
116	4C	60	40

CODE	INSERT COMBINATION ON SHELL		
	CAVITY A	CAVITY B	CAVITY C
117	blank	blank	40
118	60	30T2	5C2
119	30T2	blank	5C2
120	60	30T2	40
121	4C	4C	40
122	30T2	60	5C2

FOR SHELL SIZE 2

CODE	INSERT COMBINATION ON SHELL		
	CAVITY A	CAVITY B	CAVITY C
201	150	150	13C2
202	71C1	150	13C2
203	71C1	71C1	13C2
204	wave guide	150	13C2
205	150	71C1	13C2
206	150	150	100
207	71C1	150	100
208	150	71C1	100
209	71C1	71C1	100
210	wave guide	71C1	100
211	150	150	blank
212	71C1	71C1	blank
213	71C1	wave guide	13C2
214	wave guide	71C1	13C2
215	150	73C3	13C2
216	C2	1C71	85
217	150	C5	13C2
218	150	wave guide	13C2
219	150	2C	13C2
220	71C1	C2	85
221	1C71	71C1	13C2
222	blank	150	13C2
223	blank	blank	13C2
224	150	blank	13C2
225	150	71C 1	blank
226	150	150	85
227	150	150	34
228	C4	150	13C2
229	120T2	120T2	100
230	121	121	6T6
231	121	10T10	6T6
232	120T2	60A	6P6
233	120T2	150	100
234	60A	60A	13C2
235	150	C4	34

CODE	INSERT COMBINATION ON SHELL		
	CAVITY A	CAVITY B	CAVITY C
236	C4	C4	34
237	150	120T2	100
238	blank	60A	6P6
239	120T2	120T2	6T6
240	120T2	10T10	13C2
241	150	150	6T6
242	150	10T10	13C2
243	150	blank	100
244	150	blank	blank
245	71C1	71C1	85
246	71C1	blank	blank
247	blank	150	85
248	blank	150	100
249	blank	150	blank
250	blank	71C1	blank
251	blank	blank	100
252	blank	wave guide	100
253	C2	150	13C2
254	C2	1C71	100
255	C2	1C71	13C2
256	C2	71C1	13C2
257	C2	C2	13C2
259	C4	C4	85
260	wave guide	150	85
261	wave guide	150	100
262	150	60A	34
263	24	24	6T6
264	blank	24	100
265	24	150	13C2
266	121	121	85
267	24	24	6P6
268	60A	121	59
269	10T10	150	13C2
270	150	150	59
271	C4	120T2	13C2

CODE	INSERT COMBINATION ON SHELL		
	CAVITY A	CAVITY B	CAVITY C
272	150	150	24T4
273	150	C2	13C2
274	C2	71C1	85
275	121	60A	34
276	121	blank	100
277	1C71	150	13C2
278	71C1	1C71	13C2
279	150	121	13C2
280	120T2	121	34
281	150	121	34
282	C4	blank	13C2
283	150	60A	13C2
284	120T2	120T2	13C2
285	24	60A	100
286	60A	60A	34
287	blank	60A	100
288	blank	121	blank
289	blank	blank	85
290	150	121	100
291	121	150	100
292	121	120	blank
293	10T10	10T10	85
294	121	121	13C2
295	Q11	Q11	85
296	121	60A	6P6
297	120T2	60A	blank
298	121	60A	blank
299	blank	blank	59
501	24	60A	59
502	121	Q11	Q6
503	150	blank	11Q2
504	150	blank	34
505	Q11	blank	34
506	150	150	11Q2
507	150	150	68Q2

FOR SHELL SIZE 2 (continued)

CODE	INSERT COMBINATION ON SHELL		
	CAVITY A	CAVITY B	CAVITY C
508	24	24	100
509	150	Q11	13C2
510	121	121	100
511	24	250	100
512	Q11	Q11	62Q2
513	Q11	Q11	34
514	blank	60A	34
515	blank	blank	blank
516	121	121	34
517	blank	120T2	13C2
518	Q11	blank	62Q2
519	Q11	Q11	68Q2
520	150	121	24T4
521	Q11	150	62Q2
522	20F12T8	120T2	13C2
523	10T10	10T10	59
524	120T2	120T2	11Q2
525	24	120T2	6T6
526	10T10	10T10	100
527	120T2	120T2	85
528	150	150	11WQ2
529	35	35	62Q2
530	24	blank	85
531	10T10	24	59
532	20F12T8	121	34
533	120T2	C4	24T4
534	blank	Q11	85
535	150	35	24T4
536	blank	150	24T4
537	118Q2	118Q2	24T4
538	150	120T2	13C2
539	Q11	Q11	blank
540	120T2	C4	13C2
541	1C71	Q11	13C2

CODE	INSERT COMBINATION ON SHELL		
	CAVITY A	CAVITY B	CAVITY C
542	121	C4	Q6
543	120T2	Q11	13C2
544	120T2	120T2	24T4
545	C4	Q11	85
546	121	60A	100
547	blank	150	20Q4
548	150	35	20Q4
549	24	10T10	13C2
550	10T10	10T10	24T4
551	121	118Q2	24T4
552	150	Q11	11Q2
553	10T10	121	100
554	blank	118Q2	13C2
555	blank	71C1	13C2
556	blank	blank	62Q2
557	blank	Q11	62Q2
558	blank	Q11	blank
559	150	150	20Q4
560	150	Q11	85
561	150	120T2	85
562	121	blank	blank
563	24	24	34
564	blank	blank	34
565	150	24	34
566	150	121	blank
567	150	118Q2	blank
568	150	121	6T6
569	118Q2	118Q2	blank
570	Q11	150	11Q2
571	150	118Q2	13C2
572	150	C4	13C2
573	150	24	13C2
574	150	121	59
575	60A	150	34

CODE	INSERT COMBINATION ON SHELL		
	CAVITY A	CAVITY B	CAVITY C
576	150	150	Q6
577	1C71	118Q2	12F5C2
578	150	121	20Q4
579	C4	120T2	85
580	150	blank	59
581	118Q2	118Q2	20Q4
582	blank	71C1	11Q2
583	150	10T10	59
584	121	121	59
585	20F12Q8	blank	11Q2
586	150	Q11	34
587	150	118Q2	85
588	Q11	Q11	11Q2
589	Q11	10T10	11Q2
590	blank	Q11	Q6
591	20F12T8	150	100
592	blank	blank	11Q2
594	C4	118Q2	85
593	20F12Q8	121	blank
595	Q11	10T10	85
596	blank	118Q2	11WQ2
597	150	121	Q6
598	20F12Q8	118Q2	13C2
599	C4	24	100
801	C4	Q11	59
802	blank	120T2	24T4
803	Q11	20F12Q8	11Q2
804	Q11	20F12Q8	17F12Q2
805	10T10	150	85
806	C4	60A	59
807	Q11	150	85
808	150	35	6P6
809	C4	C4	59

FOR SHELL SIZE 3























CODE	INSERT COMBINATION ON SHELL					
	CAVITY A	CAVITY B	CAVITY C	CAVITY D	CAVITY E	CAVITY F
301	150	150	13C2	150	150	13C2
302	150	150	100	150	150	13C2
303	150	150	13C2	150	150	100
304	150	150	100	150	150	100
305	150	150	blank	150	150	blank
306	150	71C1	13C2	150	71C1	13C2
307	71C1	71C1	13C2	71C1	71C1	13C2
308	C2	C2	13C2	C2	150	100
309	150	150	13C2	150	71C1	100
310	C4	C4	13C2	blank	150	100
311	150	150	85	150	150	85
312	blank	blank	13C2	blank	blank	13C2
313	blank	blank	13C2	blank	blank	100
314	blank	blank	13C2	blank	150	100
315	150	150	13C2	150	150	blank
316	24	blank	13C2	150	150	blank
317	120T2	150	34	120T2	150	34
318	121	121	6T6	121	121	6T6
319	121	120T2	6T6	121	120T2	6T6
320	150	60A	100	150	60A	100
321	150	150	100	150	blank	blank
322	150	150	100	150	150	34
323	150	150	100	71C1	71C1	100
324	150	150	100	C2	blank	blank
325	150	150	13C2	C2	C2	13C2
326	150	71C1	100	150	150	100
327	150	71C1	100	150	150	13C2
328	C2	C2	13C2	150	150	13C2
329	C2	C2	13C2	C4	150	100
330	C4	C4	13C2	blank	blank	blank
331	71C1	150	100	150	150	100
332	C4	C4	13C2	C4	C4	85
333	71C1	71C1	100	71C1	71C1	100
334	71C1	71C1	blank	71C1	71C1	blank
335	71C1	C4	100	71C1	C4	100
336	blank	150	13C2	blank	150	13C2
337	blank	blank	100	blank	blank	13C2
338	C2	150	100	150	150	100
339	C2	C2	100	C2	C2	100
340	C2	C2	13C2	C2	C2	13C2
341	C4	C4	100	C4	C4	100
342	C4	C4	13C2	C4	C4	13C2
343	blank	150	100	150	150	13C2
344	24	150	13C2	24	150	13C2
345	60A	24	blank	60A	24	blank
346	150	24	100	150	150	34
347	150	150	6T6	121	10T10	13C2
348	C4	120T2	100	150	150	13C2
349	10T10	120T2	100	150	120T2	59
350	150	120T2	100	150	120T2	59
351	150	150	34	150	150	34
352	24	24	100	24	24	34



























CODE	INSERT COMBINATION ON SHELL					
	CAVITY A	CAVITY B	CAVITY C	CAVITY D	CAVITY E	CAVITY F
353	150	150	59	150	150	59
354	150	150	34	150	24	100
355	C4	150	13C2	blank	150	13C2
356	150	150	100	60A	60A	100
357	C4	C4	13C2	150	150	100
358	C4	C4	13C2	121	150	100
359	121	121	13C2	121	121	13C2
360	150	150	6T6	24	24	13C2
361	150	blank	13C2	150	150	blank
362	24	24	34	150	121	34
363	150	150	59	24	60A	59
364	60A	24	59	150	150	59
365	24	60A	100	24	60A	100
366	150	150	84	150	150	100
367	150	150	59	120T2	120T2	100
368	150	150	59	150	150	34
369	150	150	59	150	150	100
370	60A	60A	100	60A	60A	100
371	C4	C4	13C2	C2	150	100
372	150	150	blank	121	blank	13C2
373	150	150	13C2	120T2	120T2	100
374	150	150	68Q2	150	150	68Q2
375	150	150	100	150	150	68Q2
376	150	150	68Q2	150	150	blank
377	120T2	150	13C2	120T2	150	100
378	Q11	150	13C2	150	150	13C2
379	60A	150	34	150	150	34
380	C4	120T2	11Q2	C4	120T2	13C2
381	C4	120T2	11Q2	C4	120T2	11Q2
382	150	150	11Q2	150	150	11Q2
383	150	150	blank	Q11	150	85
384	Q11	150	85	150	150	blank
385	150	150	59	150	150	6T6
386	150	150	100	150	121	6T6
387	Q11	Q11	62Q2	Q11	Q11	62Q2
388	Q11	Q11	Q6	Q11	Q11	62Q2
389	Q11	150	11Q2	150	150	68Q2
390	150	150	11Q2	blank	blank	blank
391	150	150	100	150	10T10	34
392	10T10	24	59	10T10	24	59
393	blank	blank	13C2	150	blank	blank
394	blank	blank	13C2	150	blank	13C2
395	Q11	Q11	100	Q11	Q11	100
396	blank	blank	blank	blank	blank	blank
397	Q11	Q11	11Q2	Q11	150	11Q2
398	150	120T2	85	150	120T2	85
399	121	blank	6T6	60A	blank	13C2
601	60A	60A	13C2	60A	60A	13C2
602	Q11	150	11Q2	150	150	11Q2
603	24	blank	13C2	blank	blank	13C2
604	150	150	blank	150	150	100
605	150	Q11	11Q2	150	Q11	68Q2



















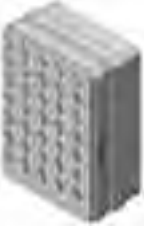



FOR SHELL SIZE 3 (continued)











CODE	INSERT COMBINATION ON SHELL					
	CAVITY A	CAVITY B	CAVITY C	CAVITY D	CAVITY E	CAVITY F
607	24	24	13C2	24	24	100
608	24	24	13C2	24	24	68Q2
609	150	150	34	150	120T2	13C2
610	150	150	34	150	Q11	13C2
611	blank	150	13C2	blank	150	100
612	10T10	150	68Q2	150	150	13C2
613	Q11	150	68Q2	150	150	13C2
614	150	150	100	blank	blank	blank
615	150	150	100	150	150	59
616	150	150	13C2	60A	120T2	34
617	60A	120T2	13C2	60A	120T2	13C2
618	150	150	Q6	150	150	Q6
619	Q11	Q11	11Q2	150	150	100
620	24	24	34	24	blank	34
621	150	150	34	150	60A	34
622	120T2	150	100	120T2	150	100
623	C4	C4	34	C4	C4	blank
624	150	150	13C2	60A	60A	34

























CODE	INSERT COMBINATION ON SHELL					
	CAVITY A	CAVITY B	CAVITY C	CAVITY D	CAVITY E	CAVITY F
625	150	150	13C2	150	150	6T6
626	C4	C4	13C2	120T2	150	100
627	C4	120T2	blank	C4	120T2	11Q2
628	150	150	11Q2	150	150	6T6
629	C4	120T2	17F12Q2	C4	120T2	11Q2
630	C4	C4	blank	C4	C4	34
631	blank	150	13C2	blank	Q11	blank
632	blank	150	13C2	150	150	68Q2
633	150	150	100	Q11	Q11	11Q2
634	150	120T2	34	150	120T2	34
635	Q11	121	11Q2	Q11	121	11Q2
636	150	150	11Q2	150	150	100
637	blank	150	11Q2	150	150	68Q2
638	Q11	150	62Q2	Q11	150	62Q2
639	Q11	121	13C2	Q11	121	13C2
640	150	Q11	34	10T10	Q11	34
641	150	150	blank	150	150	13C2
642	121	60A	59	121	60A	13C2

























Insert name	Shell size cavity	EQUIPMENT SIDE RECEPTACLE SHELL				AVIONIC SIDE PLUG SHELL	
		Version N	Version E	Version F	Version G	Version N	Version E
60	1-A/B	 60x#22 RR/RR	 60x#22 RR/RR	 60x#22 FR/FR	N/A	 60x#22 RR/RR	 60x#22 RR/RR
30T2	1-A/B	 28x#22 RR/RR 2x#8G RR/RR	 28x#22 RR/RR 2x#8G RR/RR	 28x#22 FR/FR 2x#8G RR/RR	 28x#22 FR/FR 2x#8G FR/FR	 28x#22 RR/RR 2x#8G RR/RR	 28x#22 RR/RR 2x#8G RR/RR
4C	1-A/B	 4x#5G RR/RR	Not available	N/A	 4x#5G FR/FR	 4x#5G RR/RR	Not available
40	1-C	 40x#22 RR/RR	 40x#22 RR/RR	 40x#22 FR/FR	N/A	 40x#22 RR/RR	 40x#22 RR/RR
12F12	1-C	 12x#16 RR/RR LUXCIS	 12x#16 RR/RR LUXCIS	N/A	N/A	 12x#16 RR/RR LUXCIS	 12x#16 RR/RR LUXCIS





















Insert name	Shell size cavity	EQUIPMENT SIDE RECEPTACLE SHELL				AVIONIC SIDE PLUG SHELL	
		Version N	Version E	Version F	Version G	Version N	Version E
4	1-C	 4x#12 FR/RR	 4x#12 FR/RR	N/A	Not available	 4x#12 RR/RR	 4x#12 RR/RR
5C2	1-C	 2x#5 RR/RR 1x#12 RR/RR 2x#16 RR/RR	 2x#5 RR/RR 1x#12 RR/RR 2x#16 RR/RR	N/A	 2x#5 FR/FR 1x#12 FR/FR 2x#16 FR/FR	 2x#5 RR/RR 1x#12 RR/RR 2x#16 RR/RR	 2x#5 RR/RR 1x#12 RR/RR 2x#16 RR/RR
150	2/3-A/B	 150x#22 RR/RR	 150x#22 RR/RR	 150x#22 FR/RR	N/A	 150x#22 RR/RR	 150x#22 RR/RR
121	2/3-A/B	 110x#22 RR/RR 6x#20 RR/RR 5x#16 RR/RR	 110x#22 RR/RR 6x#20 RR/RR 5x#16 RR/RR	 110x#22 FR/FR 6x#20 RR/RR 5x#16 RR/RR	 110x#22 FR/FR 6x#20 FR/FR 5x#16 FR/FR	 110x#22 RR/RR 6x#20 RR/RR 5x#16 RR/RR	 110x#22 RR/RR 6x#20 RR/RR 5x#16 RR/RR
120T2	2/3-A/B	 118x#22 RR/RR 2x#8 RR/RR	 118x#22 RR/RR 2x#8 RR/RR	 118x#22 FR/FR 2x#8 RR/RR	 118x#22 FR/FR 2x#8 FR/RR	 118x#22 RR/RR 2x#8 RR/RR	 118x#22 RR/RR 2x#8 RR/RR





















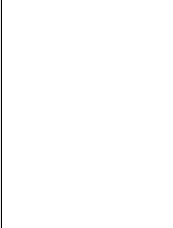



Insert name	Shell size cavity	EQUIPMENT SIDE RECEPTACLE SHELL				AVIONIC SIDE PLUG SHELL	
		Version N	Version E	Version F	Version G	Version N	Version E
110	2/3-A/B	Not available	Not available	Not available	 100x#22 FR/FR 5x#20 FR/FR 5x#12 FR/FR	 100x#22 RR/RR 5x#20 RR/RR 5x#12 RR/RR	 100x#22 RR/RR 5x#20 RR/RR 5x#12 RR/RR
60	2/3-A/B	 60x#20 RR/RR	 60x#20 RR/RR	N/A	 60x#20 FR/FR	 60x#20 RR/RR	 60x#20 RR/RR
35	2/3-A/B	 35x#16 RR/RR	 35x#16 RR/RR	N/A	 35x#16 FR/FR	 35x#16 RR/RR	 35x#16 RR/RR
24	2/3-A/B	 24x#12 RR/RR	 24x#12 RR/RR	N/A	 24x#12 FR/FR	 24x#12 RR/RR	 24x#12 RR/RR
10T10	2/3-A/B	 10x#8G FR/RR	 10x#8G FR/RR	N/A	 10x#8G FR/FR	 10x#8G RR/RR	 10x#8G RR/RR





















Insert name	Shell size cavity	EQUIPMENT SIDE RECEPTACLE SHELL				AVIONIC SIDE PLUG SHELL	
		Version N	Version E	Version F	Version G	Version N	Version E
C5	2/3-A/B	 5x#SPLG RR/RR	N/A	N/A	N/A	 5x#SPLG RR/RR	N/A
C4	2/3-A/B	 4x#1G FR/RR	N/A	N/A	 4x#1G FR/RR	 4x#1G FR/RR	N/A
73C3	2/3-A/B	 70x#22 RR/RR 3x#SPLG RR/RR	Not available	Not available	Not available	 70x#22 RR/RR 3x#SPLG RR/RR	Not available
C2	2/3-A/B	 2x#1G FR/RR	N/A	N/A	N/A	 2x#1G FR/RR	N/A
2C	2/3-A/B	 2x#1G FR/RR	N/A	N/A	N/A	 2x#1G FR/RR	N/A













Insert name	Shell size cavity	EQUIPMENT SIDE RECEPTACLE SHELL				AVIONIC SIDE PLUG SHELL	
		Version N	Version E	Version F	Version G	Version N	Version E
71C1	2/3-A/B	 70x#22 RR/RR 1x#1 FR/RR	 70x#22 RR/RR 1x#1 FR/RR	 70x#22 FR/FR 1x#1 FR/RR	N/A	 70x#22 RR/RR 1x#1 FR/RR	 70x#22 RR/RR 1x#1 FR/RR
1C71	2/3-A/B	 70x#22 RR/RR 1x#1 FR/RR	 70x#22 RR/RR 1x#1 FR/RR	 70x#22 FR/FR 1x#1 FR/RR	N/A	 70x#22 RR/RR 1x#1 FR/RR	 70x#22 RR/RR 1x#1 FR/RR
36F36	2/3-A/B	 36x#16 RR/RR LUXCIS	 36x#16 RR/RR LUXCIS	N/A	N/A	 36x#16 RR/RR LUXCIS	 36x#16 RR/RR LUXCIS
20F12Q8	2/3-A/B	 12x#16 RR/RR LUXCIS 8x#8G RR/RR	 12x#16 RR/RR LUXCIS 8x#8G RR/RR	N/A	 12x#16 RR/RR LUXCIS 8x#8G FR/FR	 12x#16 RR/RR LUXCIS 8x#8G RR/RR	 12x#16 RR/RR LUXCIS 8x#8G RR/RR
20F12T8	2/3-A/B	 12x#16 RR/RR LUXCIS 8x#8 RR/RR	 12x#16 RR/RR LUXCIS 8x#8 RR/RR	N/A	 12x#16 RR/RR LUXCIS 8x#8 FR/FR	 12x#16 RR/RR LUXCIS 8x#8 RR/RR	 12x#16 RR/RR LUXCIS 8x#8 RR/RR

Insert name	Shell size cavity	EQUIPMENT SIDE RECEPTACLE SHELL				AVIONIC SIDE PLUG SHELL	
		Version N	Version E	Version F	Version G	Version N	Version E
Q11	2/3-A/B	 11x#8G RR/RR	 11x#8G RR/RR	N/A	 11x#8G FR/FR	 11x#8G RR/RR	 11x#8G RR/RR
68Q4	2/3-A/B	 62x#22 RR/RR 6x#16 RR/RR 4x8G RR/RR	 62x#22 RR/RR 6x#16 RR/RR 4x8G RR/RR	Not available	Not available	 62x#22 RR/RR 6x#16 RR/RR 4x8G RR/RR	 62x#22 RR/RR 6x#16 RR/RR 4x8G RR/RR
118Q2	2/3-A/B	 118x#22 RR/RR 2x#8G RR/RR	 118x#22 RR/RR 2x#8G RR/RR	 118x#22 FR/FR 2x#8G RR/RR	 118x#22 FR/FR 2x#8G FR/FR	 118x#22 RR/RR 2x#8G RR/RR	 118x#22 RR/RR 2x#8G RR/RR
100	2/3-C	 100x#22 RR/RR	 100x#22 RR/RR	 100x#22 FR/FR	N/A	 100x#22 RR/RR	 100x#22 RR/RR
85	2/3-C	 80x#22 RR/RR 4x#20 RR/RR 1x#16 RR/RR	Not available	 80x#22 FR/FR 4x#20 RR/RR 1x#16 RR/RR	 80x#22 FR/FR 4x#20 FR/FR 1x#16 FR/FR	 80x#22 RR/RR 4x#20 RR/RR	 80x#22 RR/RR 4x#20 RR/RR 1x#16 RR/RR

Insert name	Shell size cavity	EQUIPMENT SIDE RECEPTACLE SHELL				AVIONIC SIDE PLUG SHELL	
		Version N	Version E	Version F	Version G	Version N	Version E
84	2/3-C	Not available	Not available	Not available	Not available	 80x#22 RR/RR 4x#20 RR/RR	 80x#22 RR/RR 4x#20 RR/RR
59	2/3-C	 50x#22 RR/RR 5x#16 RR/RR 4x#12 RR/RR	 50x#22 RR/RR 5x#16 RR/RR 4x#12 RR/RR	 50x#22 FR/FR 5x#16 RR/RR 4x#12 RR/RR	 50x#22 FR/FR 5x#16 FR/FR 4x#12 FR/FR	 50x#22 RR/ RR 5x#16 RR/RR	 50x#22 RR/RR 5x#16 RR/RR 4x#12 RR/RR
34	2/3-C	 24x#20 RR/RR 10x#16 RR/RR	 24x#20 RR/RR 10x#16 RR/RR	N/A	 24x#20 FR/FR 10x#16 FR/FR	 24x#20 RR/RR 10x#16 RR/RR	 24x#20 RR/RR 10x#16 RR/RR
6T6	2/3-C	 6x#8G FR/RR	 6x#8G FR/RR	N/A	 6x#8G FR/FR	 6x#8G RR/RR	 6x#8G RR/RR
42T4	2/3-C	Not available	Not available	 36x#22 FR/FR 2x#16 RR/RR 4x#8G FR/FR	Not available	 36x#22 RR/RR 2x#16 RR/RR 4x#8G RR/RR	Not available

Insert name	Shell size cavity	EQUIPMENT SIDE RECEPTACLE SHELL				AVIONIC SIDE PLUG SHELL	
		Version N	Version E	Version F	Version G	Version N	Version E
24T4	2/3-C	 20x#20 RR/RR 4x8G RR/RR	 20x#20 RR/RR 4x8G RR/RR	N/A	Not available	 20x#20 RR/RR 4x8G RR/RR	 20x#20 RR/RR 4x8G RR/RR
Q6	2/3-C	 6x#8G RR/RR	 6x#8G RR/RR	N/A	 6x#8G FR/FR	 6x#8G RR/RR	 6x#8G RR/RR
20Q4	2/3-C	 20x#20 RR/RR 4x#8G RR/RR	 20x#20 RR/RR 4x#8G RR/RR	N/A	 20x#20 FR/FR 4x#8G FR/FR	 20x#20 RR/RR 4x#8G RR/RR	 20x#20 RR/RR 4x#8G RR/RR
68Q2	2/3-C	 68x#22 RR/RR 2x#8G RR/RR	 68x#22 RR/RR 2x#8G RR/RR	Not available	 68x#22 FR/FR 2x#8G FR/FR	 68x#22 RR/RR 2x#8G RR/RR	 68x#22 RR/RR 2x#8G RR/RR
62Q2	2/3-C	 60x#22 RR/RR 2x#16 RR/RR 2x#8G RR/RR	 60x#22 RR/RR 2x#16 RR/RR 2x#8G RR/RR	Not available	 60x#22 FR/FR 2x#16 FR/FR 2x#8G FR/FR	 60x#22 RR/RR 2x#16 RR/RR 2x#8G RR/RR	 60x#22 RR/RR 2x#16 RR/RR 2x#8G RR/RR

Insert name	Shell size cavity	EQUIPMENT SIDE RECEPTACLE SHELL				AVIONIC SIDE PLUG SHELL	
		Version N	Version E	Version F	Version G	Version N	Version E
17F12Q2	2/3-C	 12x#16 RR/RR LUXCIS 3x#16 RR/RR 2x#8G RR/RR	 12x#16 RR/RR LUXCIS 3x#16 RR/RR 2x#8G RR/RR	N/A	 12x#16 RR/RR LUXCIS 3x#16 FR/FR 2x#8G FR/FR	 12x#16 RR/RR LUXCIS 3x#16 RR/RR 2x#8G RR/RR	 12x#16 RR/RR LUXCIS 3x#16 RR/RR 2x#8G RR/RR
11Q2	2/3-C	 4x#20 RR/RR 3x#16 RR/RR 4x#12 RR/RR 2x#8G RR/RR	 4x#20 RR/RR 3x#16 RR/RR 4x#12 RR/RR 2x#8G RR/RR	N/A	 4x#20 FR/FR 3x#16 FR/FR 4x#12 FR/FR 2x#8G FR/FR	 4x#20 RR/RR 3x#16 RR/RR 4x#12 RR/RR 2x#8G RR/RR	 4x#20 RR/RR 3x#16 RR/RR 4x#12 RR/RR 2x#8G RR/RR
11WQ2	2/3-C	 4x#20 RR/RR 3x#16 RR/RR 4x#12 RR/RR 2x#8G RR/RR	 4x#20 RR/RR 3x#16 RR/RR 4x#12 RR/RR 2x#8G RR/RR	N/A	 4x#20 FR/FR 3x#16 FR/FR 4x#12 FR/FR 2x#8G FR/FR	 4x#20 RR/RR 3x#16 RR/RR 4x#12 RR/RR 2x#8G RR/RR	 4x#20 RR/RR 3x#16 RR/RR 4x#12 RR/RR 2x#8G RR/RR
13C2	2/3-C	 4x#20 RR/RR 3x#16 RR/RR 4x#12 RR/RR 2x#5 RR/RR	 4x#20 RR/RR 3x#16 RR/RR 4x#12 RR/RR 2x#5 RR/RR	N/A	 4x#20 FR/FR 3x#16 FR/FR 4x#12 FR/FR 2x#5 FR/FR	 4x#20 RR/RR 3x#16 RR/RR 4x#12 RR/RR 2x#5 RR/RR	 4x#20 RR/RR 3x#16 RR/RR 4x#12 RR/RR 2x#5 RR/RR

Insert name	Shell size cavity	EQUIPMENT SIDE RECEPTACLE SHELL				AVIONIC SIDE PLUG SHELL	
		Version N	Version E	Version F	Version G	Version N	Version E
12F5C2	2/3-C	 1x#16 RR/RR 5x16 RR/RR LUXCIS 4x#12RR/RR 2x#5 RR/RR	 1x#16 RR/RR 5x16 RR/RR LUXCIS 4x#12RR/RR 2x#5 RR/RR	N/A	Not available	 1x#16 RR/RR 5x16 RR/RR LUXCIS 4x#12RR/RR 2x#5 RR/RR	 1x#16 RR/RR 5x16 RR/RR LUXCIS 4x#12RR/RR 2x#5 RR/RR
6P6	2/3-C	 6x#8 FR/RR	 6x#8 FR/RR	N/A	Not available	 6x#8 RR/RR	 6x#8 RR/RR
25	2/3-C	 25x#16 RR/RR	 25x#16 RR/RR	N/A	Not available	 25x#16 RR/RR	 25x#16 RR/RR

notes :

- RR/RR : rear release/rear removable
- FR/FR : front release/front removable
- FR/RR : front release/rear removable
- #8G means cavity size 8 grounded to the shell

NSX E/N/H/C - SIGNAL POWER AND GROUND CONTACTS - CRIMP

See pages 25 to 27

NSX E/N/H/C - COAXIAL, TRIAXIAL AND QUADRAX CONTACTS

See pages 30 to 42

REAR REMOVABLE PC TAIL CONTACTS

SIZE 22 SOCKET CONTACTS

PART NUMBER	CONTACT TERMINATION	DIMENSION X inch (mm)	C DIA. inch (mm)	INS/EXT TOOL	FIGURE
620 305	YA	.205 (5.20) .165 (4.20)	.025 (0.635)	282 890	
620 305 005	ZA				

SIZE 22 PIN CONTACTS

PART NUMBER	CONTACT TERMINATION	DIMENSION X inch (mm)	C DIA. inch (mm)	INS/EXT TOOL	FIGURE
620 202	Y	.288 (7.30) .250 (6.30)	.025 (0.635)	282 890	
620 202 005	Z				

REAR REMOVABLE WIRE WRAP CONTACTS

SIZE 22 SOCKET CONTACTS

PART NUMBER	CONTACT TERMINATION	DIMENSION X inch (mm)	INS/EXT TOOL	FIGURE
620 302	K	.303 (7.70) .248 (6.30)	282 890	
620 303	V			
620 308	W			

HOW TO ORDER

NSX F 3 R 301 Y 00 01

Series _____

Class _____

F : receptacle connectors, non environmental.

For this version, the size 22 contacts cavities only are for front release front release front removable contacts. Signal contacts defined by termination code are delivered installed. Power contacts (size 20, 16, 12) are delivered with crimp termination. Coaxial and twinax contacts are to be ordered separately.

G : receptacle connectors, non environmental.

For this version, signal (size 22), power (size 20, 16, 12), size 5 coaxial and size 8 coaxial or triaxial contact cavities are for front removable contacts. Size 1 coaxial contacts remain front release/rear removable. Signal and power contacts are delivered installed. Coaxial and twinax contacts are to be ordered separately.

Shell size _____

1 : size 1

2 : size 2

3 : size 3

Shell style _____

R : Alodine 1200 plated receptacle

F : Nickel plated receptable

Insert combination code (see note 1) _____

Contacts termination _____

X : without contacts

K : wire wrap contact, 1 level (1 = .272)

V : wire wrap contact, 2 levels (1 = .390)

W : wire wrap contact, 3 levels (1 = .524)

L : wire wrap contact, 4 levels (1 = .660)

Y : pc tail contact length = .250

YA : pc tail contact length = .150

YB : pc tail contact dia length = .375

YC : pc tail contact dia length = .500

Z : pc tail contact length = .250 pre-tinned

ZA : pc tail contact length = .150 pre-tinned

ZB : pc tail contact dia length = .375 pre-tinned

ZC : pc tail contact dia length = .500 pre-tinned

Modification code _____

See pages 22 to 24

Polarization code (see note 3) _____

See pages 19 and 21

* Add 001 to these P/N to order dor environmental contacts

note 1: See insert combinaison codes on pages 74 to 77 and contact arrangements on pages 78 to 87.

note 2: For F version, contact termination code is attributable to signal contacts (size 22) only.

For G version, contact termination code is attributable to signal contacts (size 22) to power contacts (size 20, 16, 12) (Power contacts are offered in solder tail version only).

note 3: Without termination code, the connector is delivered polarization hardware unassembled.

Polarization code 00, the connector is delivered without polarizing hardware.

Polarization code from 01 to 216, the connector is delivered with the polarization hardware assembled as defined by the code.

Remark: dust caps conductive on receptacle and are included in the delivery.

SIZE 22 SOCKET CONTACTS

PART NUMBER	CONTACT TERMINATION	DIMENSION X mm (inch)	INS/EXT TOOL	COLOR BAND 1	COLOR BAND 2	FIGURE
620 360	YA	4.2/0.4 (.150/.181)	282 500	orange	green	
620 360 005	ZA					
620 361	Y	6.8/0.4 (.252/.283)				
620 361 005	Z					
620 362	YB	9.9/0.4 (.374/.406)				
620 362 005	ZB					
620 363	YC	13.2/0.4 (.504/.535)				
620 363 005	ZC					

SIZE 20 PIN CONTACTS

PART NUMBER	CONTACT TERMINATION	DIMENSION X mm (inch)	INS/EXT TOOL	COLOR BAND 1	COLOR BAND 2	E DIA mm (inch)	FIGURE
620 214 018	YA	4.6/3.8 (.181/.150)	282 503	orange	red	0.81/0.05 (.030/.034)	
620 214 019	ZA						
620 214 010	Y	6.8/0.4 (.252/.283)					
620 214 013	Z						
620 214 003	YB	9.9/0.4 (.374/.405)					
620 214 008	ZB						
620 214 021	YC	13.6/12.8 (.535/.504)					
620 214 022	ZC						

SIZE 16 PIN CONTACTS

PART NUMBER	CONTACT TERMINATION	DIMENSION X mm (inch)	INS/EXT TOOL	COLOR BAND 1	COLOR BAND 2	E DIA mm (inch)	FIGURE
620 234 018	YA	4.6/3.8 (.181/.150)	282 504	orange	blue	1.27/0.05 (.048/.052)	
620 234 019	ZA						
620 234 004	Y	6.8/0.4 (.252/.283)					
620 234 017	Z						
620 234 003	YB	9.9/0.4 (.374/.405)					
620 234 008	ZB						
620 234 021	YC	13.6/12.8 (.535/.504)					
620 234 022	ZC						

SIZE 12 PIN CONTACTS

PART NUMBER	CONTACT TERMINATION	DIMENSION X mm(inch)	INS/EXT TOOL	COLOR BAND 1	COLOR BAND 2	FIGURE
620 244 018	YA	4.6/3.8 (.181/.150)	282 549 005	orange	yellow	
620 244 019	ZA					
620 244 005	Y	6.8/0.4 (.252/.283)	282 549 005	orange	yellow	
620 244 016	Z					
620 244 003	YB	9.9/0.4 (.374/.405)	282 549 005	orange	yellow	
620 244 008	ZB					
620 244 021	YC	13.6/12.8 (.535/.504)	282 549 005	orange	yellow	
620 244 022	ZC					

SIZE 8 PIN QUADRAX CONTACTS

PART NUMBER	CONTACT TERMINATION	DIMENSION X mm(inch)	INS/EXT TOOL
620 176 009	YA	3.8/4.6 (.150/.181)	282 549 009
620 176 016*	ZA	3.8/5.1 (.150/.200)	
620 176 008	Y	6.4/7.2 (.252/.283)	
620 176 010*	Z	6.4/7.7 (.252/.303)	
620 176 011	YB	9.5/10.3 (.374/.405)	
620 176 012*	ZB	9.5/10.8 (.374/.425)	
620 176 013	YC	12.8/13.6 (.504/.535)	
620 176 014	ZC	12.8/14.1 (.504/.555)	

SIZE 22 SOCKET FRONT REMOVABLE WIRE WRAP CONTACTS

PART NUMBER	CONTACT TERMINATION	DIMENSION X (inch) mm	INS/EXT TOOL	COLOR BAND 1	COLOR BAND 2	FIGURE
620 350	K	6.9/0.4 (.256/.287)	282 500	orange	green	
620 351	V					
620 352	W					
620 353	L					

* tin lead finish

SIZE 16 PIN COAX CONTACT

PART NUMBER	CONTACT TERMINATION	DIMENSION X inch (mm)	INS/EXT TOOL
618 155 001	YA	3.8/4.6 (.150/.181)	282 504
618 155 002	Y	6.4/7.2 (.252/.283)	
618 155 011	YB	9.5/10.3 (.374/.405)	

SIZE 12 PIN COAX CONTACT

PART NUMBER	CONTACT TERMINATION	DIMENSION X inch (mm)	INS/EXT TOOL
618 149 017	YA	3.8/4.6 (.150/.181)	282 549 005
618 149 016	Y	6.4/7.2 (.252/.283)	
618 149 018	YB	9.5/10.3 (.374/.405)	
618 149 012	YC	12.8/13.6 (.503/.535)	
618 149 013**	ZC	12.8/14.1 (.503/.558)	

SIZE 8 PIN COAX CONTACT

PART NUMBER	CONTACT TERMINATION	DIMENSION X inch (mm)	INS/EXT TOOL
619 140 009	YA	3.8/4.6 (.150/.181)	282 549 009
619 140 014**	ZA	3.8/5.1 (.150/.200)	
619 140 010	Y	6.4/7.2 (.252/.283)	
619 140 013**	Z	6.4/7.2 (.252/.283)	
619 140 007	YB	9.5/10.3 (.374/.405)	
619 140 008**	ZB	9.5/10.8 (.374/.425)	
619 140 011	YC	12.8/13.6 (.503/.535)	
619 140 012**	ZC	12.8/14.1 (.503/.555)	

SIZE 5 PIN COAX CONTACT

PART NUMBER	CONTACT TERMINATION	DIMENSION X inch (mm)	INS/EXT TOOL
620 133 009	YA	3.8/4.6 (.150/.181)	282 549 006
620 133 006	Y	6.4/7.2 (.252/.283)	
620 133 001	YB	9.5/10.3 (.374/.405)	
620 133 001	YC	12.8/13.6 (.503/.535)	

** tin lead finish

SIZE 8 PIN TRIAX PC TAIL FRONT RELEASE VERSION

PART NUMBER	CONTACT TERMINATION	DIMENSION X inch (mm)	INS/EXT TOOL
619 162 014	YA	3.8/4.6 (.150/.181)	282 549 009
619 162 015**	ZA	3.8/5.1 (.150/.200)	
619 162 011	Y	6.4/7.2 (.252/.283)	
619 162 012**	Z	6.4/7.7 (.252/.303)	
619 162 016	YB	9.5/10.3 (.374/.405)	
619 162 017**	ZB	9.5/10.8 (.374/.425)	
619 162 009	YC	12.8/13.6 (.503/.535)	
619 162 010**	ZC	12.8/14.1 (.503/.555)	

SIZE 8 PIN QUADRAX PC TAIL FRONT RELEASE VERSION

PART NUMBER	CONTACT TERMINATION	DIMENSION X inch (mm)	INS/EXT TOOL
620 176 009	YA	3.8/4.6 (.150/.181)	282 549 009
620 176 016**	ZA	3.8/5.1 (.150/.200)	
620 176 008	Y	6.4/7.2 (.252/.283)	
620 176 010**	Z	6.4/7.7 (.252/.303)	
620 176 011	YB	9.5/10.3 (.374/.405)	
620 176 012**	ZB	9.5/10.8 (.374/.425)	
620 176 013	YC	12.8/13.6 (.503/.535)	
620 176 014**	ZC	12.8/14.1 (.503/.555)	

** tin lead finish

DESCRIPTION

NSX single shell connectors are designed to accommodate inserts and contacts for NSX E/N/H/C and F connectors. Their characteristics are those shown on page 6 except for the following.



MATERIAL

DESCRIPTION	MATERIAL	PLATING
Shell	Aluminum alloy	Cadmium clear chromate or nickel
Insert retention plate	Aluminum alloy	Cadmium clear chromate or nickel
Polarization posts and keys retention plate	Aluminum alloy	Cadmium clear chromate or nickel
Screws washers and clinch-nuts	Stainless steel	/
	Steel	Cadmium clear chromate
Polarization posts and keys	Zinc alloy	Cadmium yellow chromate or nickel

HOW TO ORDER

	<u>NSX</u>	<u>N</u>	<u>P</u>	<u>150</u>	<u>S</u>	<u>00</u>	<u>01</u>
Series _____							
Class _____							
N : non environmental (rear removable version only) E : environmental, with grommets and compound. plug with O-ring (rear removable version only). H : environmental plug without O-ring (rear removable version only) C : non environmental with grommets (rear removable version only) F : non environmental receptable shell } (see definition page 89) G : non environmental receptacle shell }							
Shell style _____							
R : Cadmium clear chromate plated receptacle P : Cadmium clear chromate plated plug F : Nickel plated receptable B : Nickel plated plug M : Nickel plated plug fitted with grounding spring fingers (see pages 102 to 106)							
Contact arrangement _____							
See contact arrangements on pages 78 to 87							
Contacts termination (see note 1) _____							
X : without contacts S : crimp contacts K : wire wrap contact, 1 level V : wire wrap contact, 2 levels W : wire wrap contact, 3 levels Y : pc tail contact length = .250 YA : pc tail contact length = .150 YB : pc tail contact length = .375 YC : pc tail contact length = .500 Z : pc tail contact length = .250 pre-tinned ZA : pc tail contact length = .150 pre-tinned ZB : pc tail contact length = .375 pre-tinned ZC : pc tail contact length = .500 pre-tinned							
Modification code _____							
00 : 4 mounting holes .146/.156 dia 01 : 4 clinch nuts 4.40 UNC 03 : 4 each .122 dia mounting holes c'sunk .230 dia x 100∇ 04 : 4 each .122 dia mounting holes c'sunk .230 dia x 82∇ 05 : 4 each .137 dia mounting holes c'sunk .230 dia x 82∇ 23 : 4 floating eyelets .122 - .126 dia							
Polarization code (see note 2) _____							
See pages 96 and 97							

note 1: Define the signal contact termination code except for G version which in this case define the termination code for all contacts sizes except coax and twinax. Power contacts (sizes 8, 12, 16 and 20) will be delivered with crimp termination except for G version. If you need to use reduced crimp barrel contacts, use code X and order signal and power contacts separately.

Coax, twinax and quadax contacts are to be ordered separately

note 2: Without polarization code, the connector is delivered polarization hardware unassembled.

Polarization code 00, the connector is delivered without polarization hardware.

Polarization code 01 to 36, the connector is delivered with the polarization hardware assembled as defined by the code.

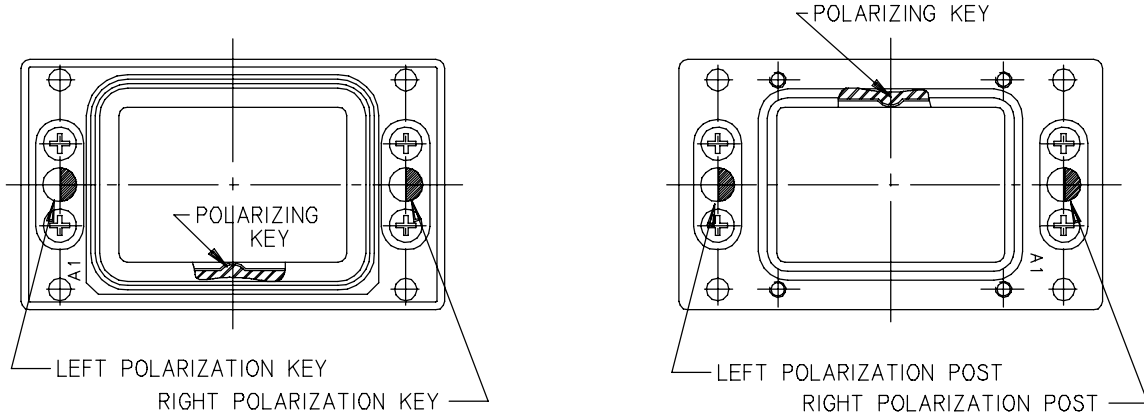

MATING FACE

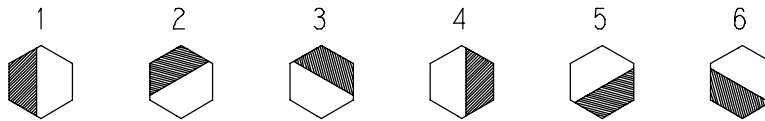

POSITION OF POST (DARK) AND KEYHOLE (LIGHT)

POSITION	EQUIPMENT RECEPTACLE		RACK PLUG	
	LT. KEY	RT. KEY	LT. POST	RT. POST
01	1	1	1	1
02	3	4	4	5
03	2	4	4	6
04	1	4	4	1
05	6	4	4	2
06	5	4	4	3
07	4	5	3	4
08	3	5	3	5
09	2	5	3	6
10	1	5	3	1
11	6	5	3	2
12	5	5	3	3
13	4	6	2	4
14	3	6	2	5
15	2	6	2	6
16	1	6	2	1
17	6	6	2	2
18	5	6	2	3
19	4	1	1	4
20	3	1	1	5
21	2	1	1	6
22	4	4	4	4
23	6	1	1	2
24	5	1	1	3
25	4	2	6	4
26	3	2	6	5
27	2	2	6	6
28	1	2	6	1
29	6	2	6	2
30	5	2	6	3
31	4	3	5	4
32	3	3	5	5
33	2	3	5	6
34	1	3	5	1
35	6	3	5	2
36	5	3	5	3

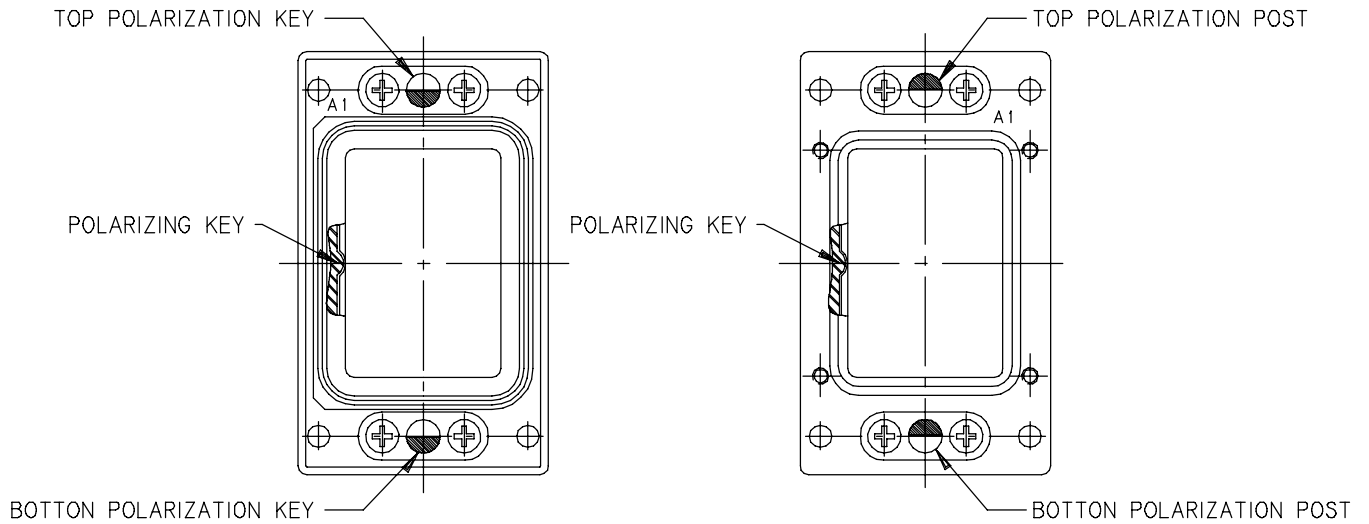

MATING FACE

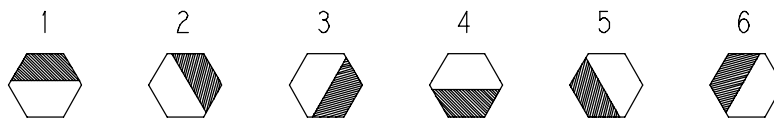

POSITION OF POST (DARK) AND KEYHOLE (LIGHT)

POSITION	EQUIPEMENT RECEPTACLE		RACK PLUG	
	LT. KEY	RT. KEY	LT. POST	RT. POST
01	1	1	4	4
02	3	4	2	1
03	2	4	3	1
04	1	4	4	1
05	6	4	5	1
06	5	4	6	1
07	4	5	1	6
08	3	5	2	6
09	2	5	3	6
10	1	5	4	6
11	6	5	5	6
12	5	5	6	6
13	4	6	1	5
14	3	6	2	5
15	2	6	3	5
16	1	6	4	5
17	6	6	5	5
18	5	6	6	5
19	4	1	1	4
20	3	1	2	4
21	2	1	3	4
22	4	4	1	1
23	6	1	5	4
24	5	1	6	4
25	4	2	1	3
26	3	2	2	3
27	2	2	3	3
28	1	2	4	3
29	6	2	5	3
30	5	2	6	3
31	4	3	1	2
32	3	3	2	2
33	2	3	3	2
34	1	3	4	2
35	6	3	5	2
36	5	3	6	2

NSX- ARINC 600

NSX SINGLE SHELL RECEPTACLE DIMENSIONS

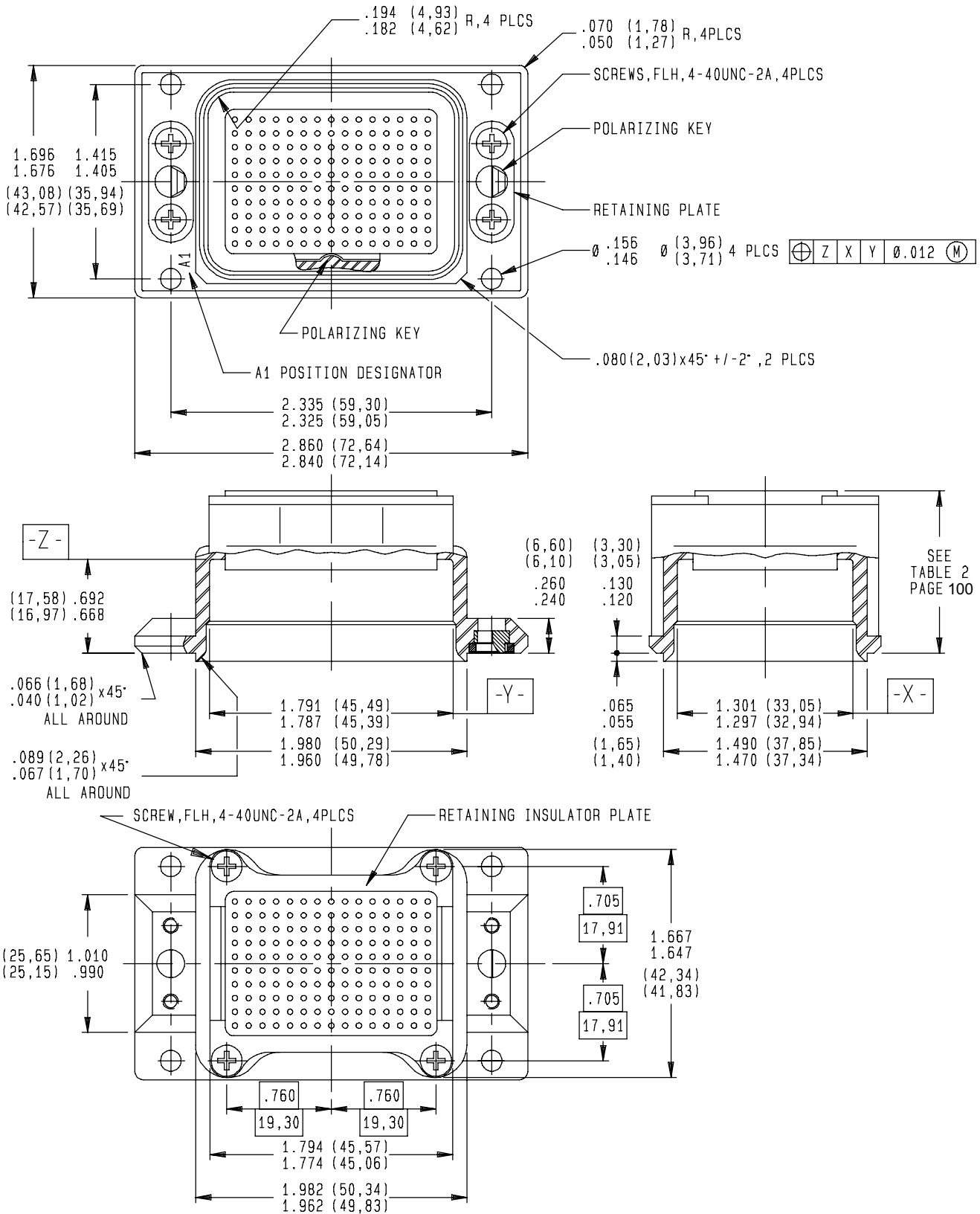

NSX- ARINC 600

NSX SINGLE SHELL PLUG DIMENSIONS

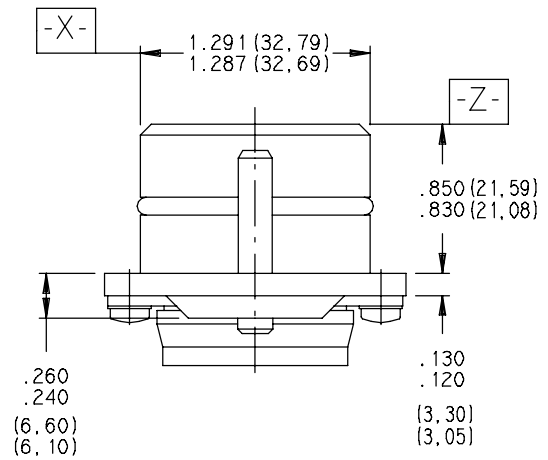
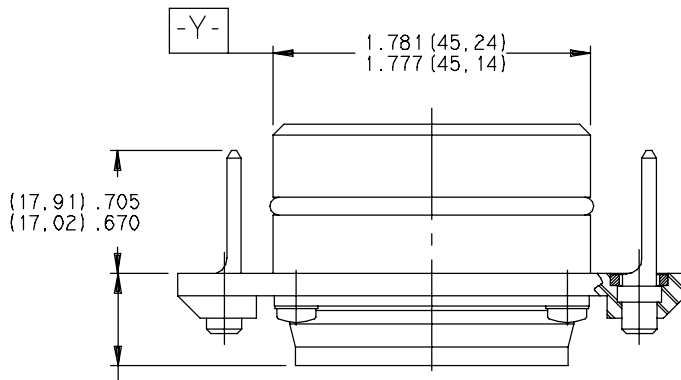
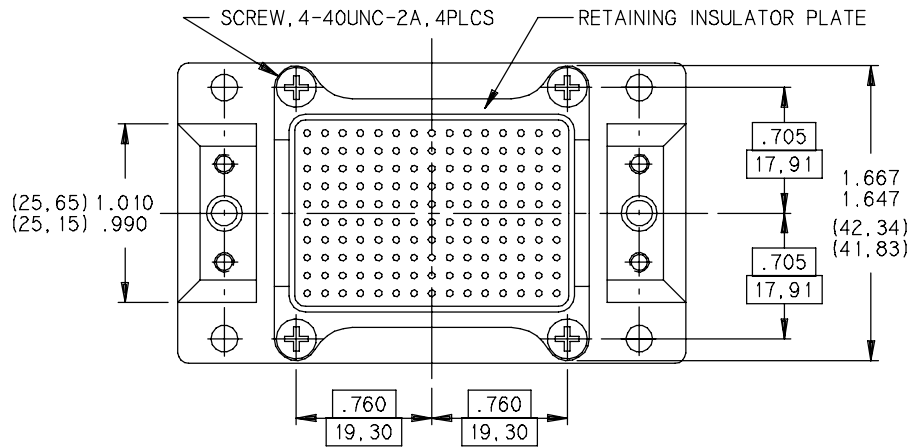

SEE
TABLE 1
PAGE 100

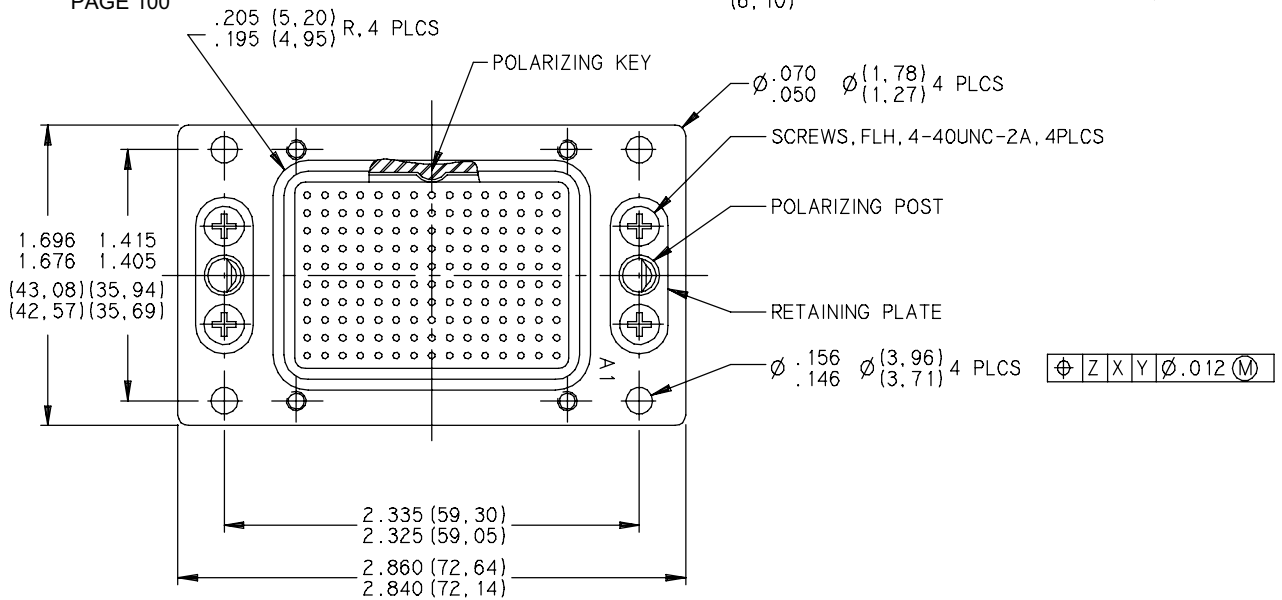

PLUG CONNECTOR

CONTACT ARRANGEMENTS inch (mm) VERSION	150	121	120T2	71C1	60	10T10	C4	C2 - 2C
N	.242 max (6.14 max)	.351 max (8.92 max)	.255 max (6.47 max)	.257 max (6.54 max)	.354 max (8.98 max)	.349 max (8.86 max)	.279 max (7.09 max)	.134 max (3.40 max)
E	.531 max (13.50 max)	.696 max (17.69 max)	.600 max (15.22 max)	.547 max (13.90 max)	.682 max (17.33 max)	.693 max (17.61 max)	/	/

TABLE 1

RECEPTACLE CONNECTOR

CONTACT ARRANGEMENTS inch (mm) VERSION	150	121	120T2	71C1	60	10T10	C4	C2 - 2C
E	1.483 max (37.68 max)	1.648 max (41.87 max)	1.551 max (39.40 max)	1.500 max (38.08 max)	1.650 max (41.91 max)	1.645 max (41.79 max)	/	/
N	1.213 max (30.82 max)	1.500 max (38.10 max)	1.207 max (30.65 max)	1.209 max (30.72 max)	1.306 max (33.16 max)	1.300 max (33.04 max)	1.231 max (31.27 max)	1.088 max (27.63 max)
F	1.207 max (30.66 max)	1.203 max (30.56 max)	1.203 max (30.56 max)	1.207 max (30.66 max)	1.203 max (30.56 max)	/	/	/

TABLE 2

FULLY MATED CONDITION

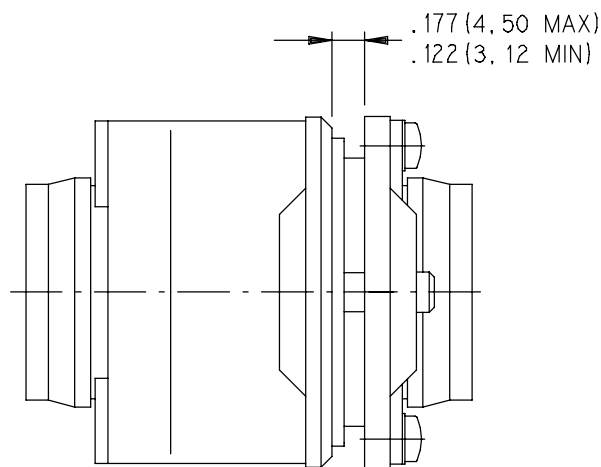

RECEPTACLE
PANEL CUT OUT

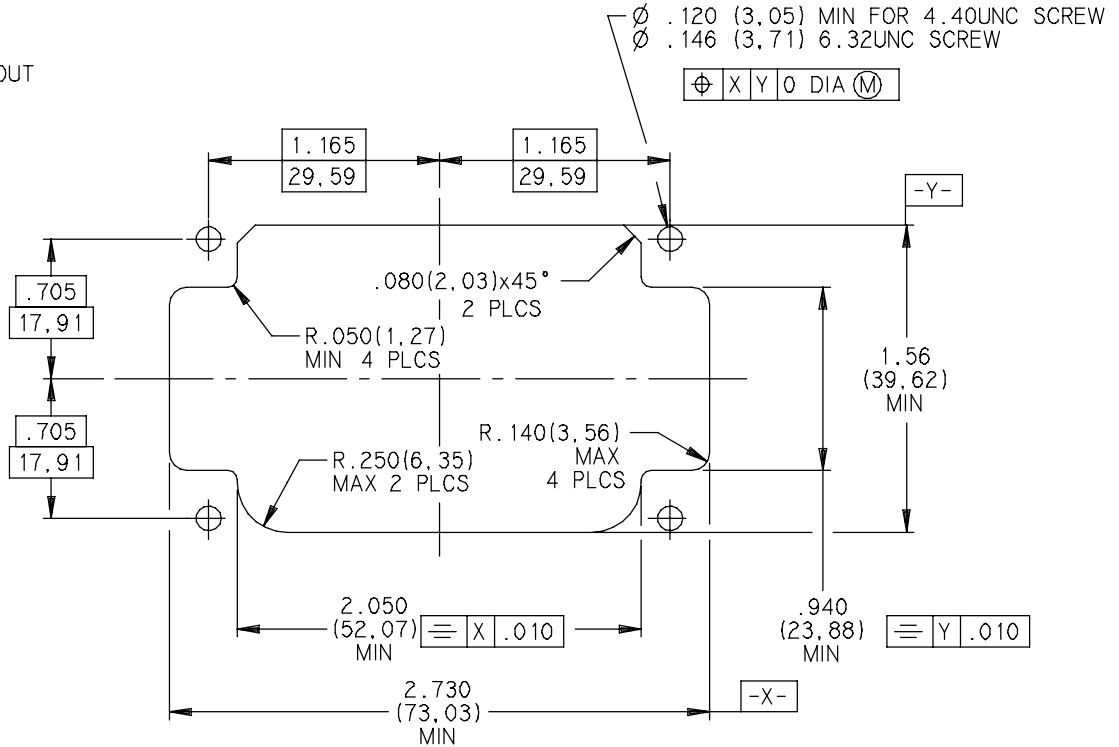

PLUG
PANEL CUT OUT

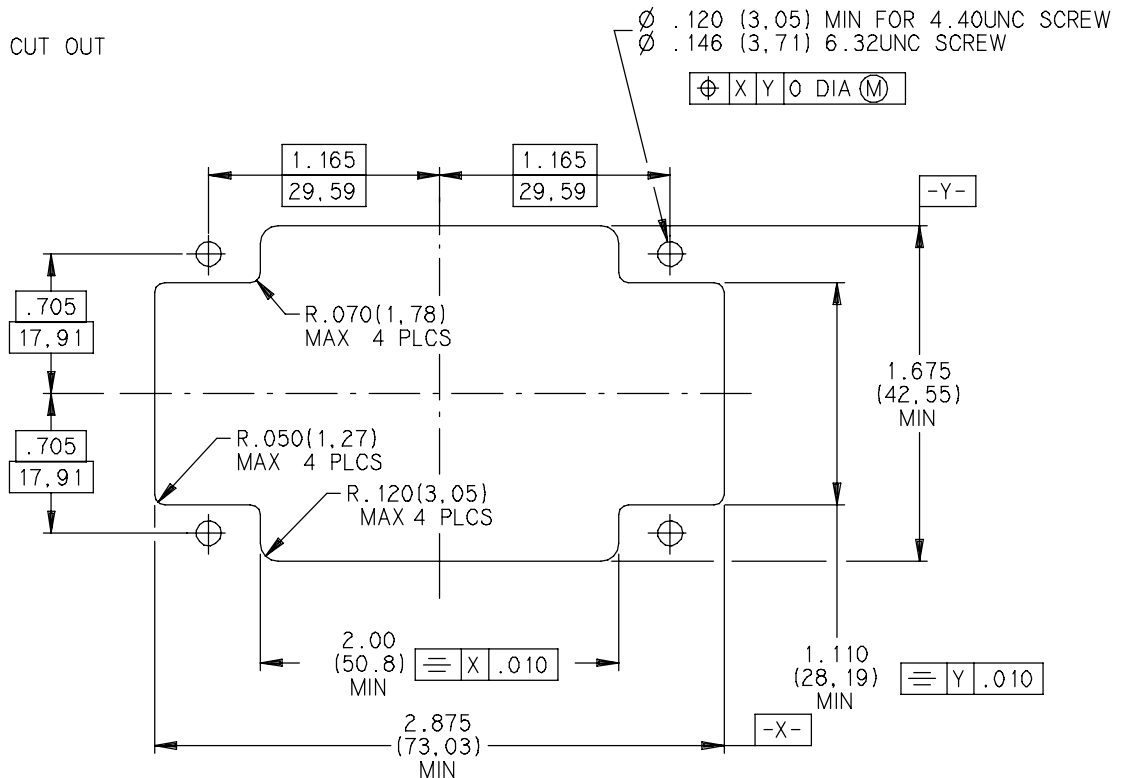

DESCRIPTION

EMI/RFI acts directly on electronics systems whether by conduction through the input or input cables or by induction (coupling).

Electronics equipments are particularly vulnerable to interferences and can be disturbed or damaged by them. The serious consequences which may result, make it essential to protect such installations.

The first stage in protection is to install the equipment in a metal surround (FARADAY cage) which protect it from some of the interferences ; particularly those occuring by induction. At the connector level that means to use metallic shells so as to have a good mass conduction between the equipment box and the rack.

So as to meet these requirements **RADIALL** offers plug connectors for rack which are fitted with ground spring fingers.

Interferences acting by conduction through the cables can be attenuated by using **RADIALL** filtered connectors.

Sizes 1, 2 and 3 plugs connectors fitted with ground spring fingers are available. These connectors can be mated with ARINC 600 receptacle connectors. Their technical characteristics are the same than those shown on page 6 except the following.



MATERIAL

DESCRIPTION	MATERIAL	PLATING
Shell	Aluminum alloy	Electroless nickel
Ground spring fingers	Copper alloy	Electroless nickel

ELECTRICAL CHARACTERISTICS

- shell to shell conductivity :
(measured according to method 3007 of MIL-STD-1344A),
max warranty : 2,5 mΩ .
- size 8 cavity grounding :
(measured according to method 3007 of MIL-STD-1344A),
max warranty : 10,0 mΩ .
- EMI shielding effectiveness :
(measured according to S280W552).
The minimum values warranty are the following :

FREQUENCY (MHz)	LEAKAGE ATTENUATION (dB)
100	65
200	63
300	63
400	62
800	60
1000	60

HOW TO ORDER (see page 95)

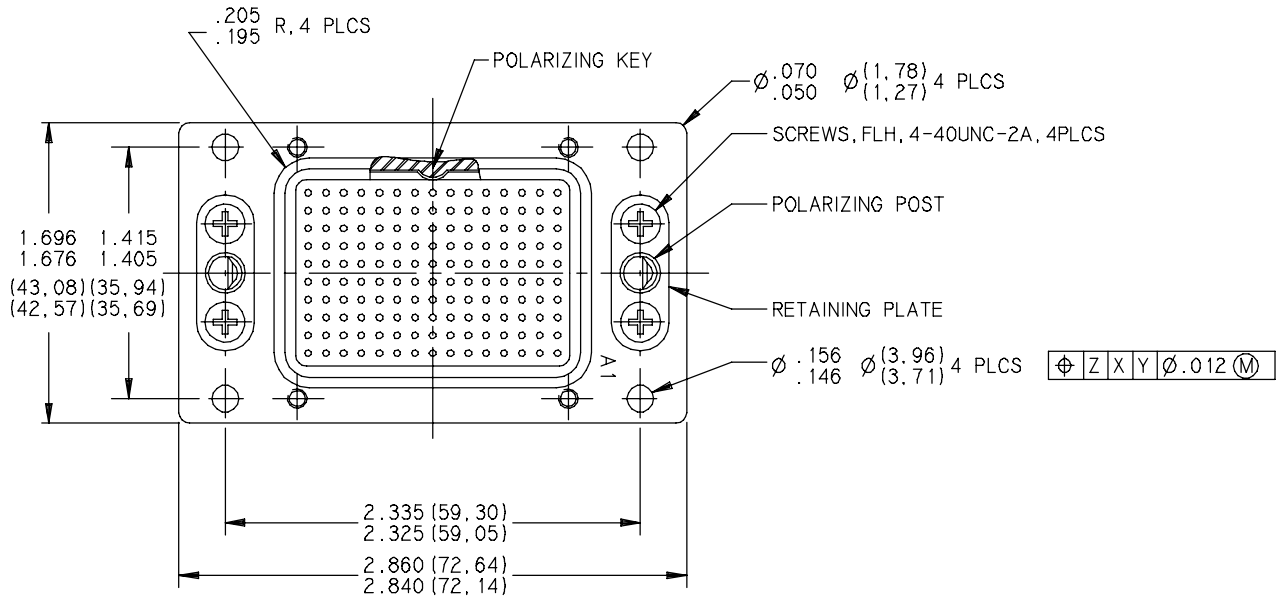
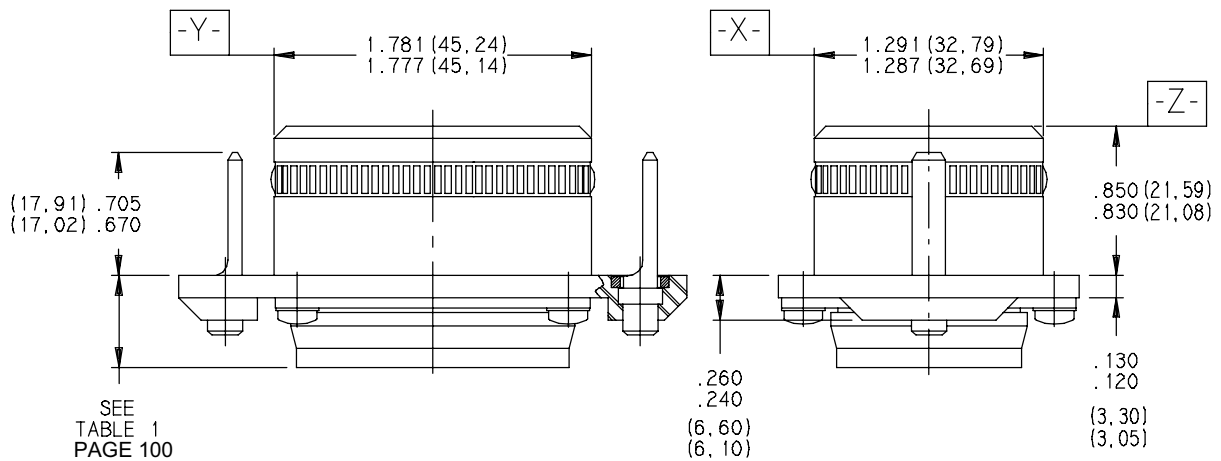

HOW TO ORDER (see pages 73 and 89)

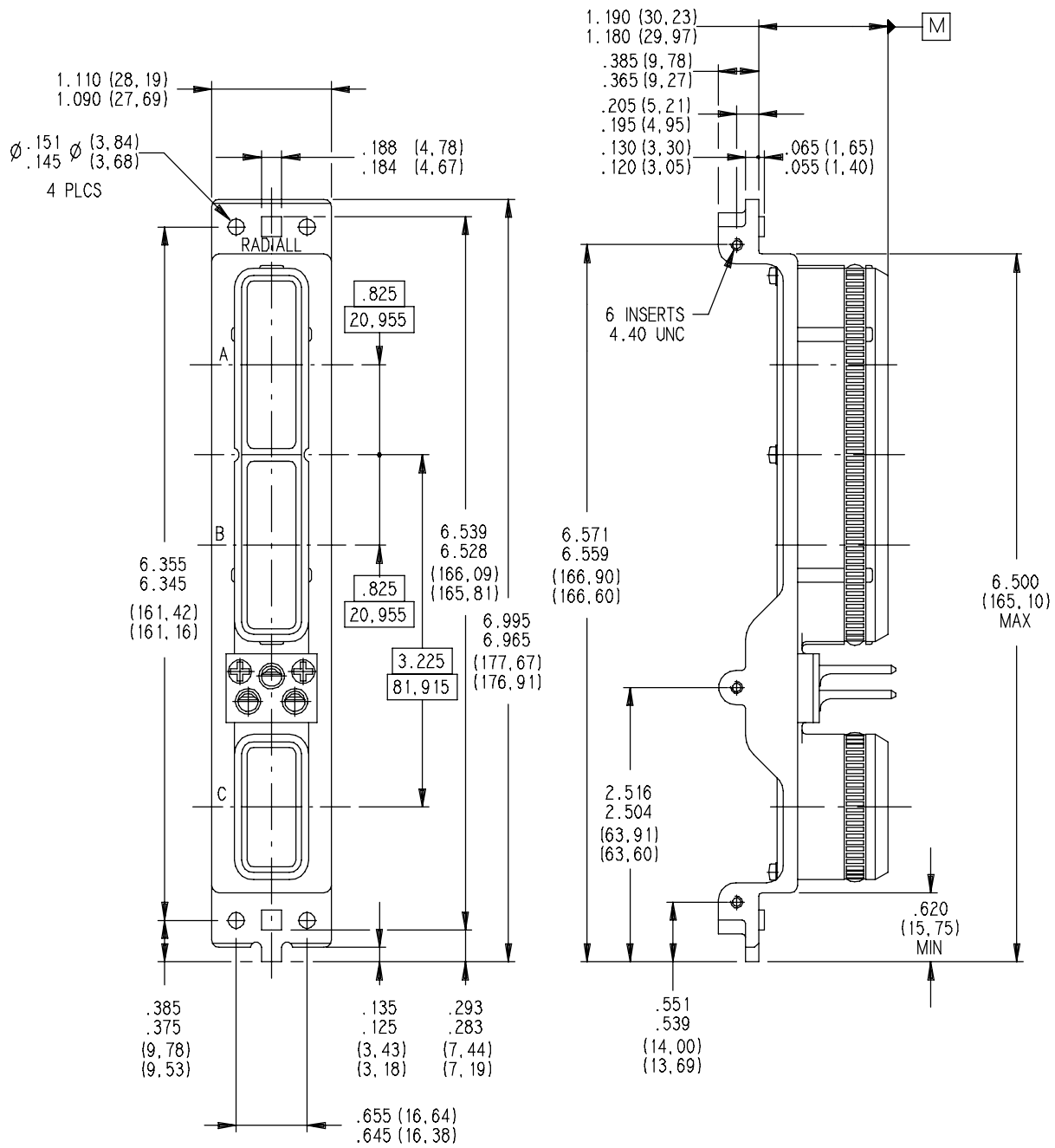

HOW TO ORDER (see pages 73 and 89)

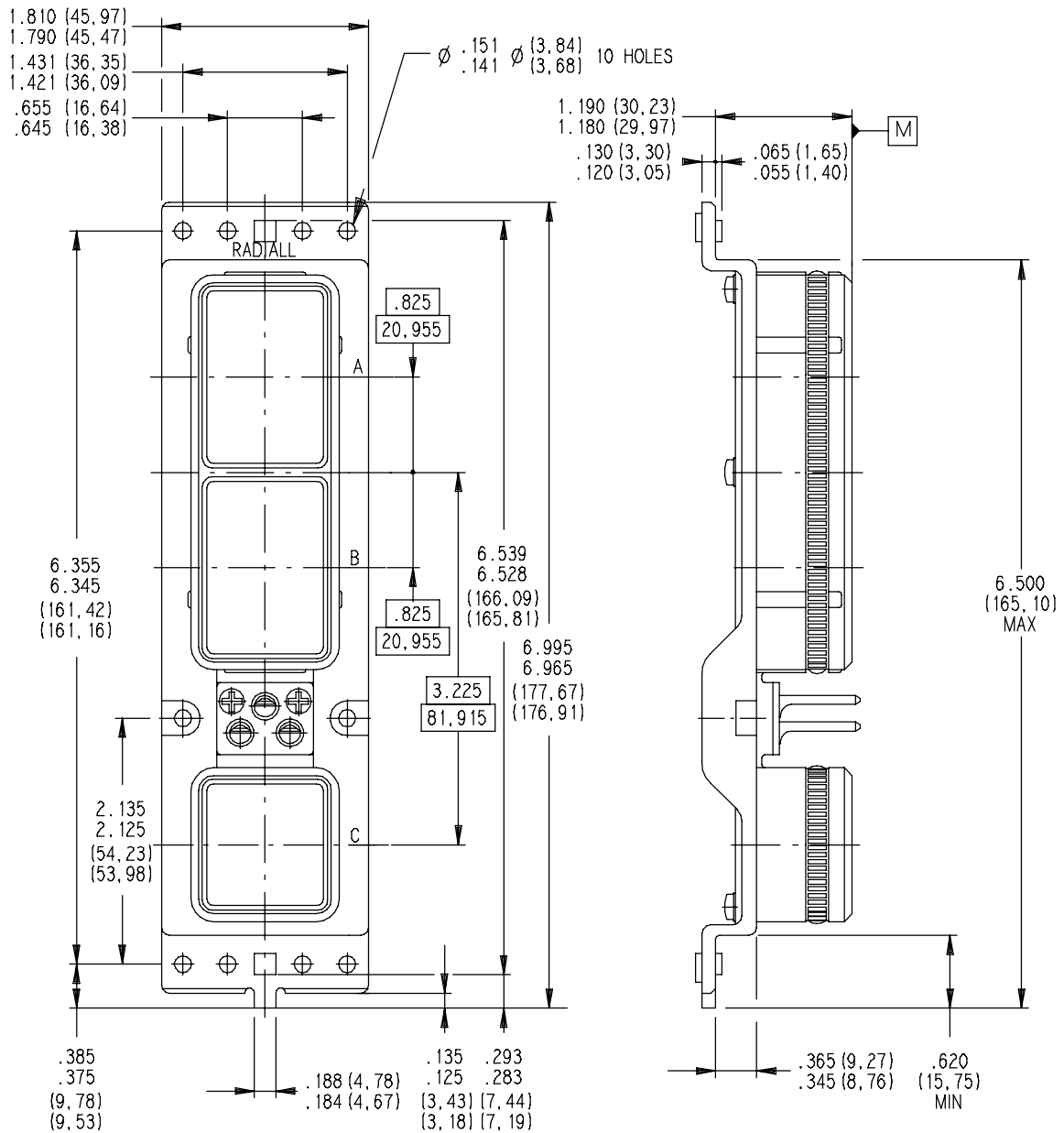

HOW TO ORDER (see pages 73 and 89)

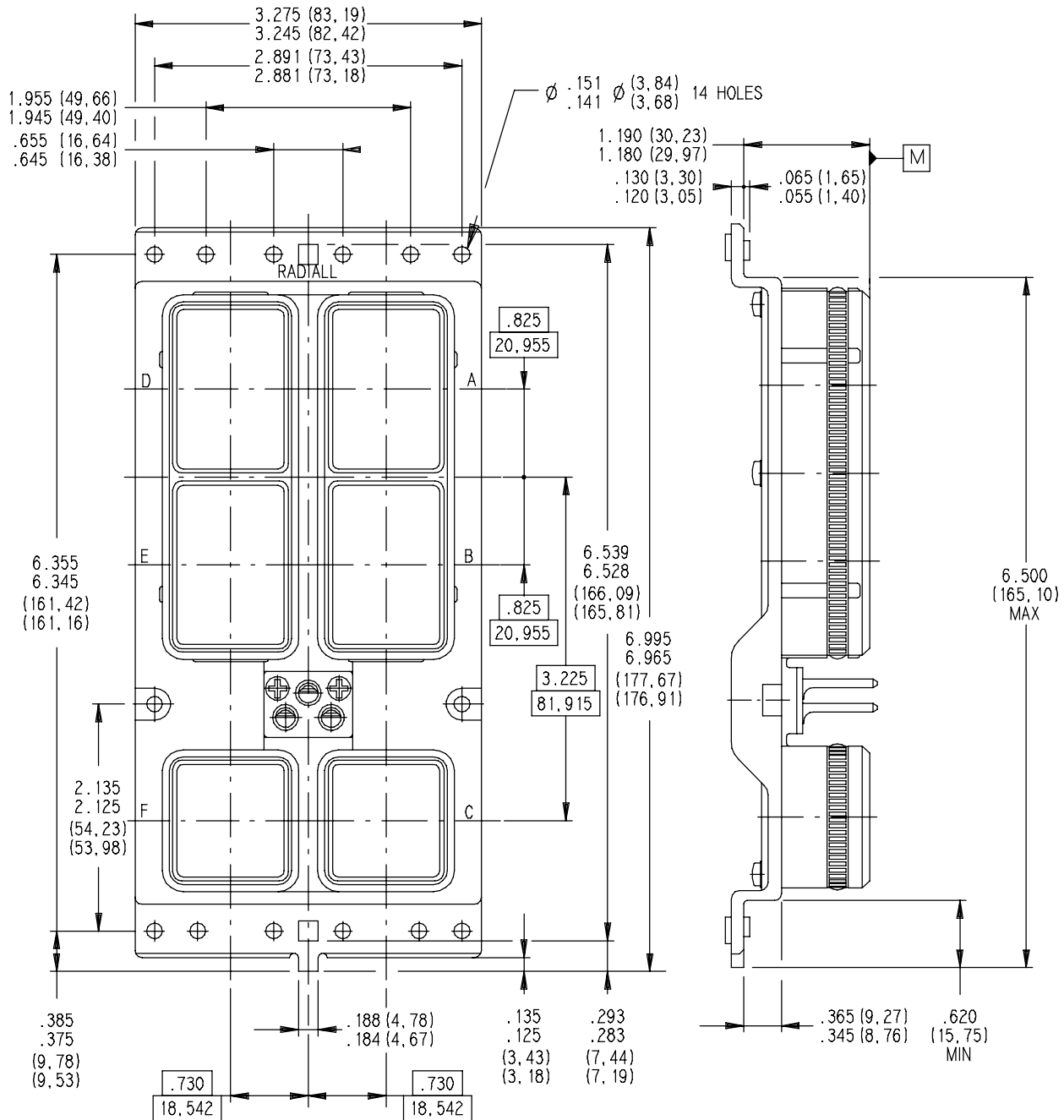

DESCRIPTION

NSX T CAS connectors are installed on equipments for use on T CAS (Traffic collision Avoiding system). These environmental or non environmental rear release rear removable (receptacle can use front release front removable contacts) and Alodine 1200 (can be electroless nickel plated) plated plugs and receptacles are size 3 connectors only. The environmental version has compound around each insert except C4 inserts. NSX T CAS connectors have a single insert combination code of 310 :

- shell cavity A : C4 insert,
- shell cavity B : C4 insert,
- shell cavity C : 13C2 insert,
- shell cavity D : dummy insert,
- shell cavity E : 150 insert,
- shell cavity F : 100 insert.

C4 insert uses size 1 RF coaxial contacts (see pages 109-110).

Connectors have technical characteristics as shown on page 6 except for C4 insert material and plating which is the following :



C4 INSERT MATERIAL AND PLATING

CODE (see page 109)	INSERT FOR PLUG	INSERT FOR RECEPTACLE
Without	Mating side insert : - thermoplastic Size 1 RF coax retention plate : - stainless steel	Aluminum alloy nickel plated
N	Aluminum alloy nickel plated	Aluminum alloy nickel plated

HOW TO ORDER

NSX N 3 P 310 X 00 01

Series _____

Class _____

N : non environmental

E : environmental, with grommets and compound. Plug with O-ring

H : environmental, plug without O-ring

C : non environmental, with grommets

Shell size _____

3 : size 3

Shell style _____

R : Alodine 1200 plated receptacle

P : Alodine 1200 plated plug

F : Nickel plated receptacle

B : Nickel plated plug

M : Nickel plated plug fitted with grounding spring fingers

Insert combination code _____

310 only

Contacts termination (see note 1) _____

X : without contacts

S : crimp contacts

K : wire wrap contact, 1 level

V : wire wrap contact, 2 levels

Y : pc tail contact length = .250

YA : pc tail contact length = .150

Z : pc tail contact length = .250 pre-tinned

ZA : pc tail contact length = .150 pre-tinned

Modification code _____

See pages 22 to 24

Polarization code (see note 2) _____

See pages 19 to 21

Coax contact delivery code _____

See page 109

* Add 001 to these P/N to order dor environmental contacts

note 1: Define the signal contact termination code. Power contacts (sizes 8, 12, 16 and 20) will be delivered with crimp termination. If you need to use reduced crimp barrel contacts, use code X and order signal and power contacts separately.
Coax and twinax contacts are to be ordered separately.

note 2: Without polarization code, the connector is delivered polarization hardware unassembled.







Polarization code 00, the connector is delivered without polarization hardware.

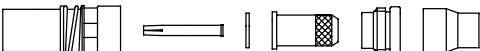
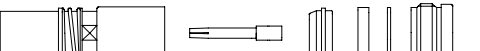
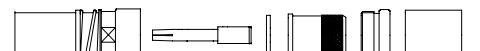

Polarization code 01 to 216, the connector is delivered with the polarization hardware assembled as defined by code.

HOW TO ORDER (continued)

CODE	CONNECTOR DELIVERY	COAXIAL CONTACT PART NUMBER FOR PLUG	COAXIAL CONTACT PART NUMBER FOR RECEPTACLE
Without	Size 1 RF coaxial contacts to be ordered separately	620 117 620 145 620 146 620 147 620 148 620 149	620 049
N	Connector delivered with coaxial contacts	620 116	

SIZE 1 RF COAXIAL CONTACTS FOR NSX T CAS CONNECTOR

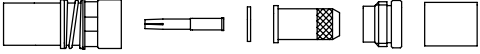
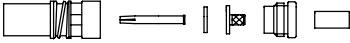
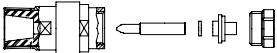
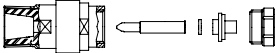
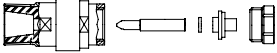
CABLE	CONTACT TYPE	PART NUMBER	CONTACT	WIRING INSTRUCTIONS
TNC TERMINATION	Socket	620 116		Not applicable
TNC TERMINATION	Pin	620 017		Not applicable
ASNE 0406WD ECS 311 201	Socket	620 117		G (Page 48)
RG 225 RG 393	Socket	620 119 100		W (Page 59)
ECS 310801	Socket	620 119 102		G (Page 48)
RG 214 & SURPRENANT BA 6903A	Socket	620 145		G (Page 48)
RG 142 RG 400 TIMES AA6343 ECS 3C142B ASNE 0293XF	Socket	620 146		J (Page 50)
TIMES AA5887	Socket	620 147		G (Page 48)

CABLE	CONTACT TYPE	PART NUMBER	CONTACT	WIRING INSTRUCTIONS
TIMES AA5886	Socket	620 148		G (Page 48)
TIMES AA5888 & ECS 311 601	Socket	620 149		G (Page 48)
RG 142	Pin	620 046		G (Page 48)
UT 141	Pin	620 047		Y (Page 60)
UT .085	Pin	620 047 010		Y (Page 60)
SMA TERMINATION	Pin	620 049		Not applicable
ASNE0692WN- ASNE0406WD	Pin	620 019 105		<i>TDS contact available at http://www.radiall.com</i>
ASNE0692WN	Socket	620 119 105		<i>TDS contact available at http://www.radiall.com</i>

WAVE GUIDE CONNECTOR

Plug and receptacle size 2 NSX connector can be fitted with a wave guide in shell cavities A and B. These wave guides are made of aluminum alloy and chromatation plated.

CHARACTERISTICS

- Frequency range : 9330 to 9345 MHz

HOW TO ORDER

Ordering instructions, see page 108

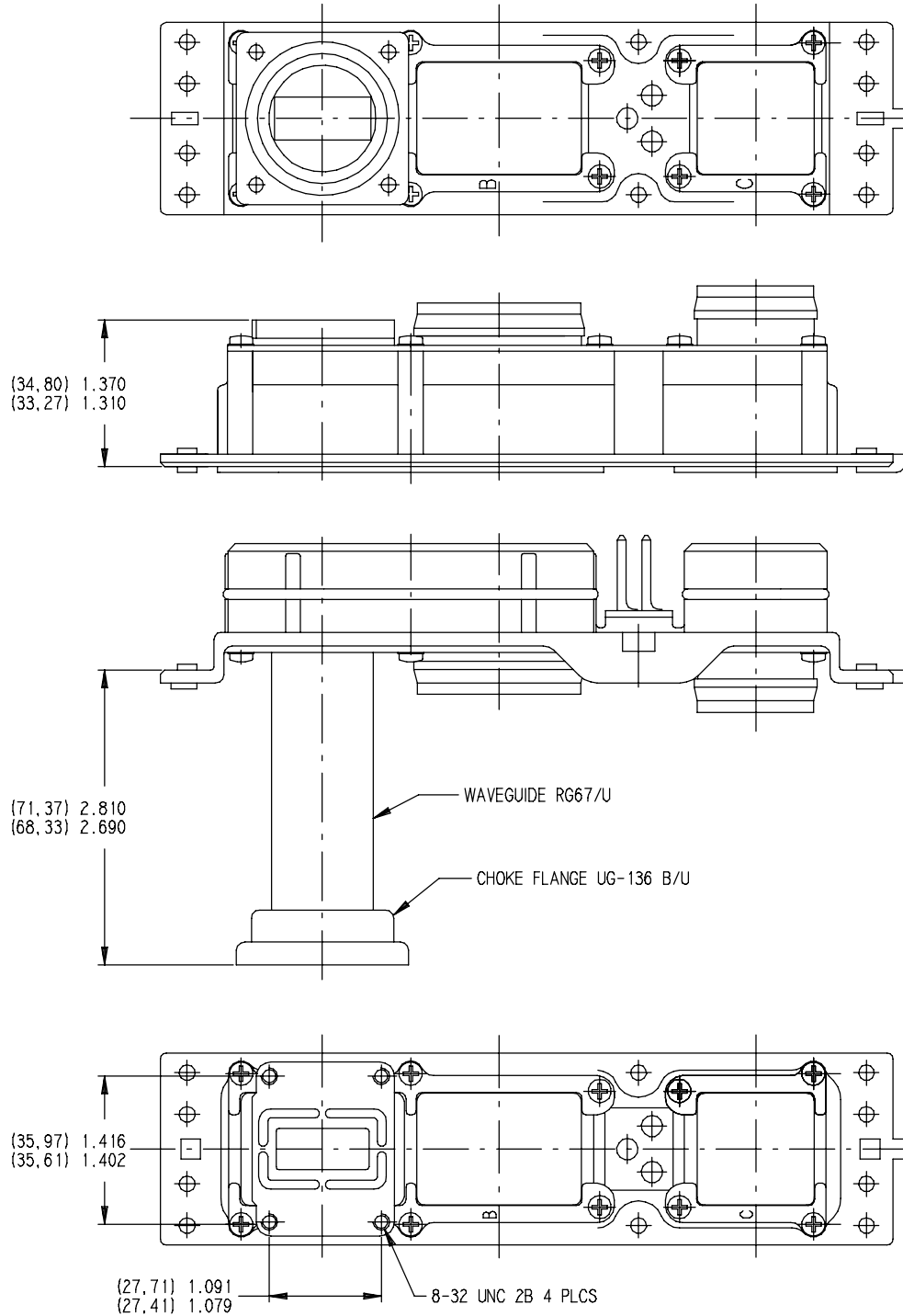

DESCRIPTION

BPX series connectors are EMI shielded and modular insert concept rectangular multipin connectors fitted with NSX inserts and contacts.

BPX connectors can be differentiate from NSX connectors by their shells sizes available in three sizes (1, 2 and 3).

The **BPX** characteristics are conforming to BOEING S280W551 specification. Their specific characteristics (those which are different from NSX connectors) are the following :



MATERIAL

DESCRIPTION	MATERIAL	PLATING
Shell	Aluminum alloy	Electrically conductive finish over nickel
Grounding spring fingers	Copper alloy	Nickel
Insert retention plate	Aluminum alloy	Nickel
Polarization posts and keys retention plate	Aluminum alloy	Nickel
Screws, washers and clinch nuts	Stainless steel	
Polarization posts and keys	Zinc alloy	Nickel

ELECTRICAL CHARACTERISTICS

BPX electrical characteristics are the same as NSX connectors (see pages 6 and 102) except the following :

- Magnetic permeability : 2.0 max.

MECHANICAL AND ENVIRONMENTAL CHARACTERISTICS

They are the same as for NSX connectors except the following :

- Mating and unmating forces :
 - . shell size 1 : 70 pounds (311 N) max,
 - . shell size 2 : 140 pounds (623 N) max,
 - . shell size 3 : 130 pounds (578 N) max.
- Humidity : type II
(measured according to method 1002 of MIL-STD-1344A).
- Fluid resistance : resistance to MIL-STD-1344A method 1016 (fluids a, e, i, j).
- Contact stability : conforming to S280W551 requirements.

HOW TO ORDER

	<u>BPX</u>	<u>E</u>	<u>2</u>	<u>P</u>	<u>201</u>	<u>S</u>	<u>00</u>	<u>01</u>
Series _____	Class _____		Shell size _____	Shell style _____	Insert combination code _____	Contacts termination (see note 2) _____	Modification code _____	Polarization code (see note 3) _____
<p>See insert combinaison codes on page 114</p> <p>See pages 19 to 21</p>								

- N : connector without grommets
- E : connector with grommets
- F : connector for front removable contacts } (see definition page 89 and
- G : connector for front removable contacts } note 1)

- 1 : size 1
- 2 : size 2
- 3 : size 3

- R : receptacle
- P : plug

- X : without contacts
- S : crimp contacts
- K : wire wrap contact, 1 level
- V : wire wrap contact, 2 levels
- W : wire wrap contact 3 levels
- Y : pc tail contact length = .250
- YA : pc tail contact length = .150
- YB : pc tail contact length = .375
- YC : pc tail contact length = .500
- Z : pc tail contact length = .250 solder dipped
- ZA : pc tail contact length = .150 solder dipped
- ZB : pc tail contact length = .375 solder dipped
- ZC : pc tail contact length = .500 solder dipped

* Add 001 to these P/N to order dor environmental contacts

note 1: Available inserts for front removable contacts are shown on pages 78 to 87.

Coax and twinax contacts are to be ordered separately.

note 2: Define the signal contact termination code. If you need to use reduced crimp barrel contacts, use code X and order signal and power contacts separately.

note 3: Without polarization code, the connector is delivered with the polarization hardware unassembled.

Polarization code 00, the connector is delivered without polarization hardware. Polarization code 01 to 216, the connector is delivered with the polarization hardware as defined by the code.

CODE	INSERT COMBINAISON ON SHELL				
	A	B	C	D	E
101	10T10	34	/	/	/
102	10T10	59	/	/	/
103	150	13C2	/	/	/
201	150	100	150	6T6	/
202	121	6T6	150	6T6	/
203	10T10	100	10T10	100	/
204	121	6T6	121	6T6	/
205	110	6T6	150	6T6	/
301	10T10	4	6P6	60	4
302	10T10	30T2	6P6	60	30T2
303	120T2	4	6P6	60	4

CONTACTS

BPX connectors use NSX signal, power coaxial and concentric twinax contacts (see pages 25 to 42, 90 to 93).

SEALING BOOT

The sealing boots are designed to slide down over the back of crimped contacts after they have been installed in the connector. The assembly provide bend support and moisture sealing to the contact/cable assembly. For BPX connectors size, 8 coaxial and concentric twinax contacts must be fitted with the sealing boot required by S280W552 specification

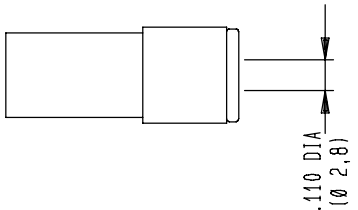
CONTACT	WIRE DIA	WIRE TYPE	PART NUMBER	FIGURE
8	.145	Tensonite (S280W502-1)	619 960 005	

Dust caps are made of thermoplastic material, they can be conductive (black color) or not (red color).

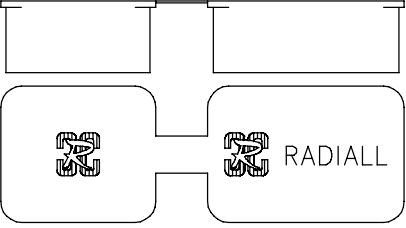
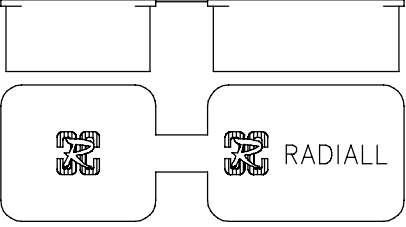
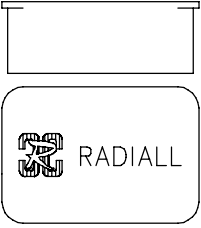
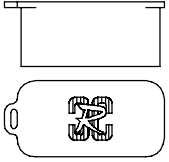
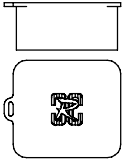
TYPE	SHELL TYPE	SHELL SIZE	CAVITY	PART NUMBER	FIGURE
Conductive	Plug	1	A and B	618 953 002	
		2	A and B C and D		
		3	A, D	620 995 007	
			B, E	620 995 004	
		C	620 995 008		

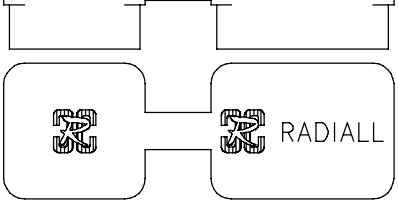
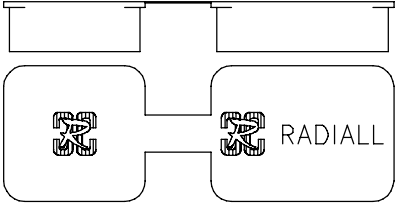
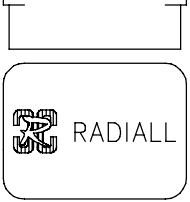
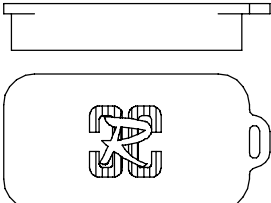
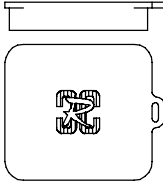
TYPE	SHELL TYPE	SHELL SIZE	CAVITY	PART NUMBER	FIGURE
Conductive	Receptacle	1	A and B	618 953 001	
		2	A and B C and D		
		3	A, D	620 995 018	
			B, E	620 995 012	
			C	620 995 016	

TYPE	SHELL TYPE	SHELL SIZE	CAVITY	PART NUMBER	FIGURE
Non conductive	Plug	1	A and B	618 953	
		2	A and B C and D		
		3	A, D	620 995 017	
			B, E	620 995 002	
			C	620 995 006	

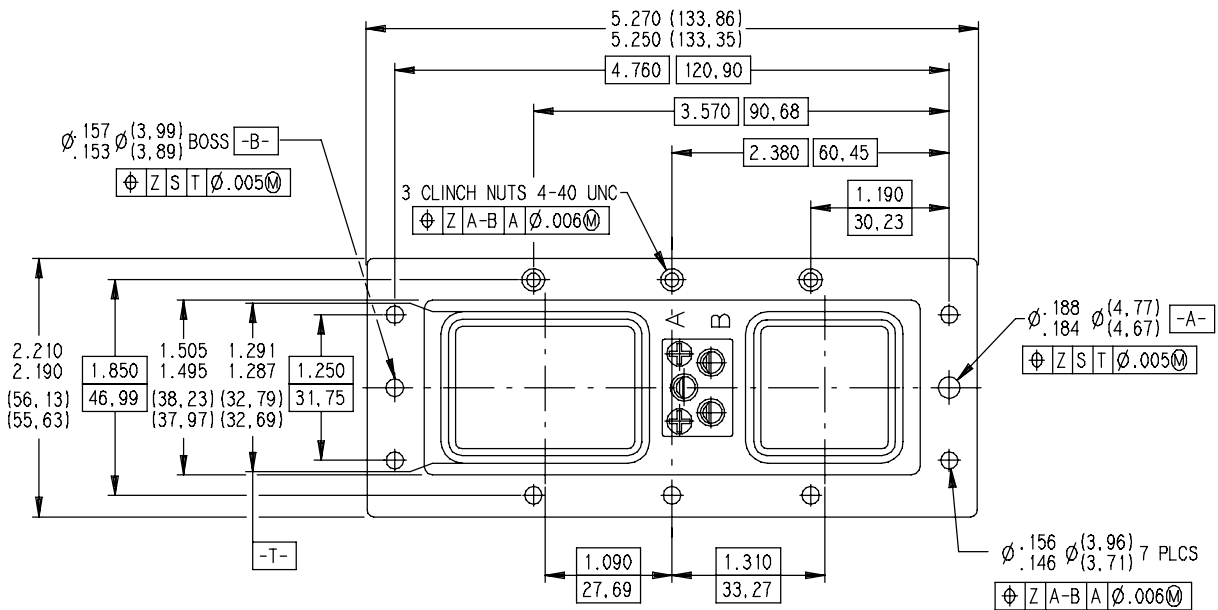
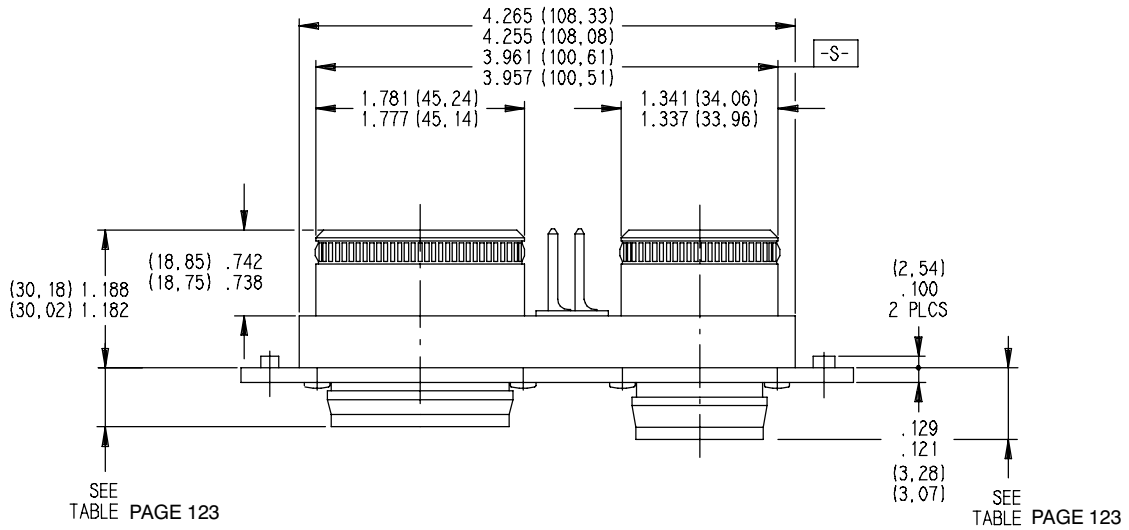

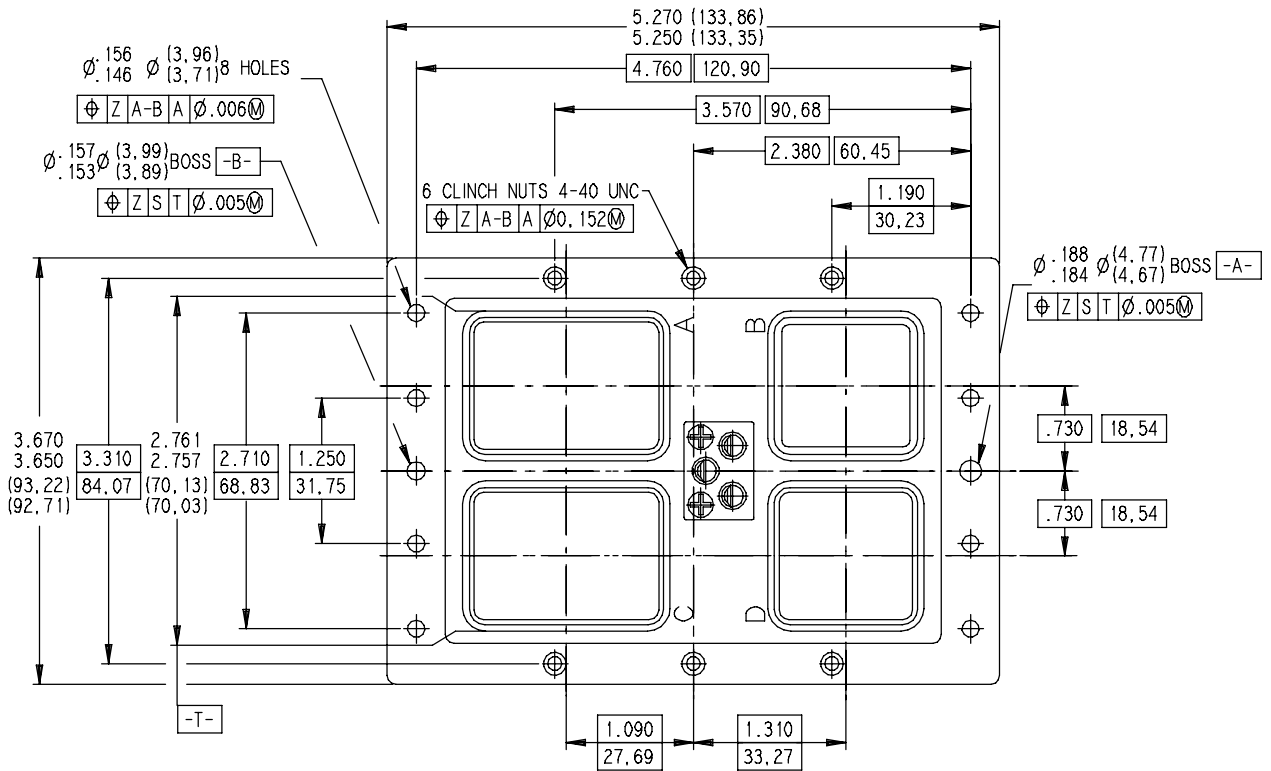
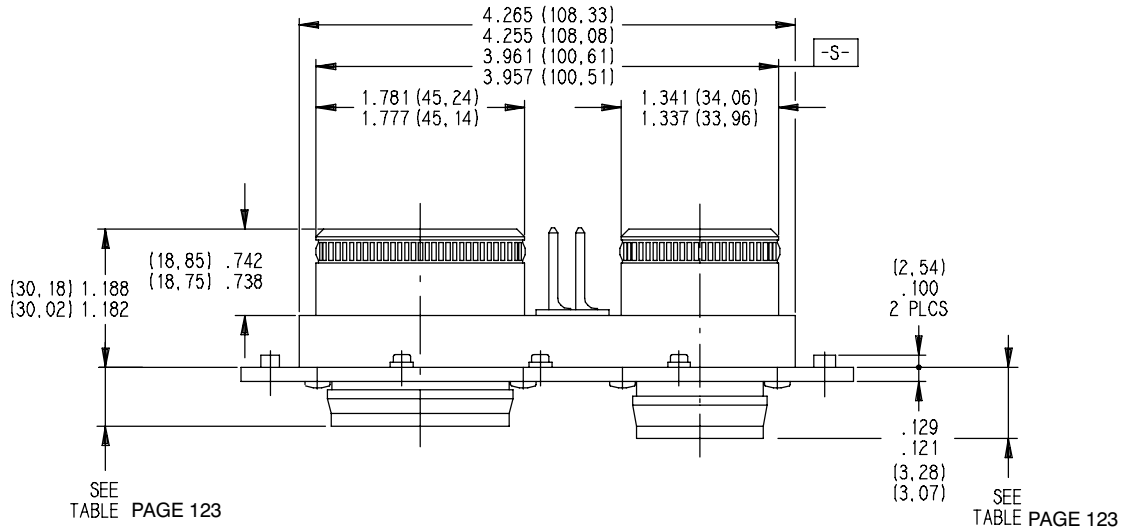

SIZE 3 PLUG DIMENSIONS

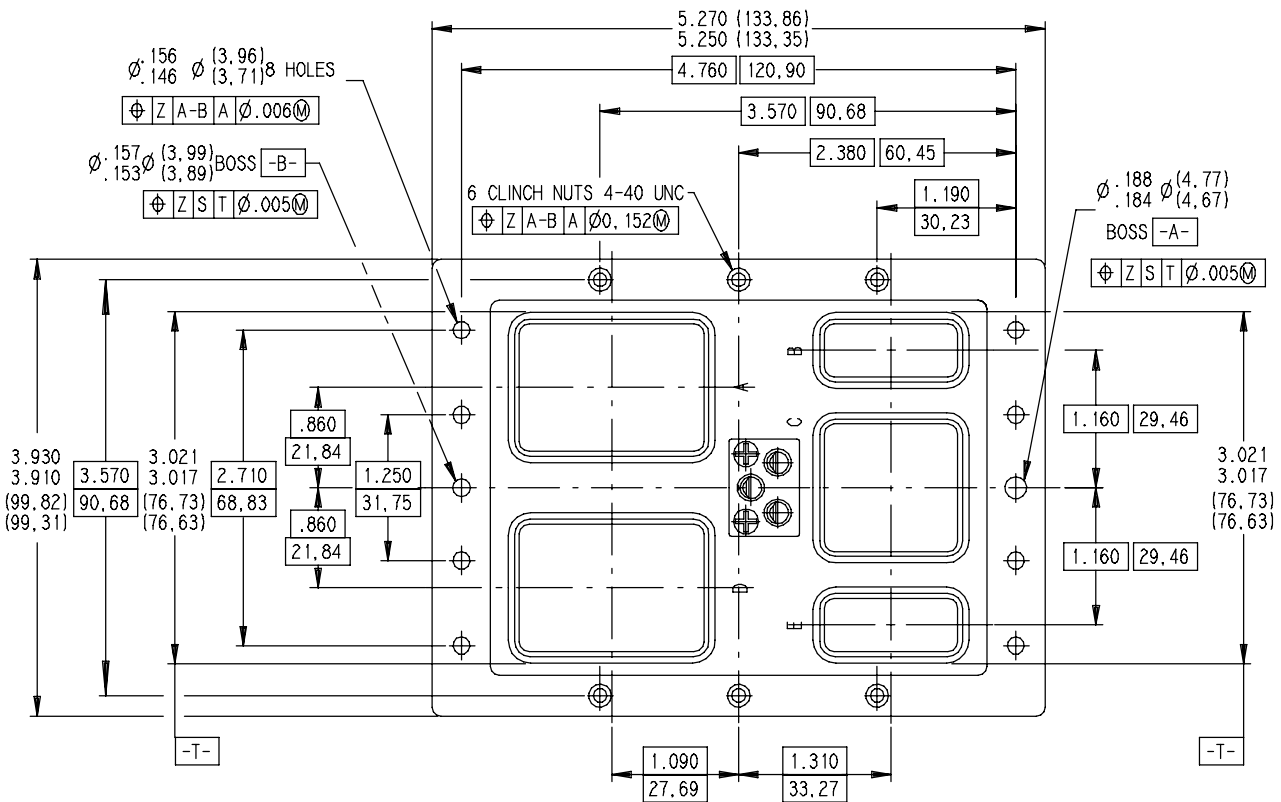
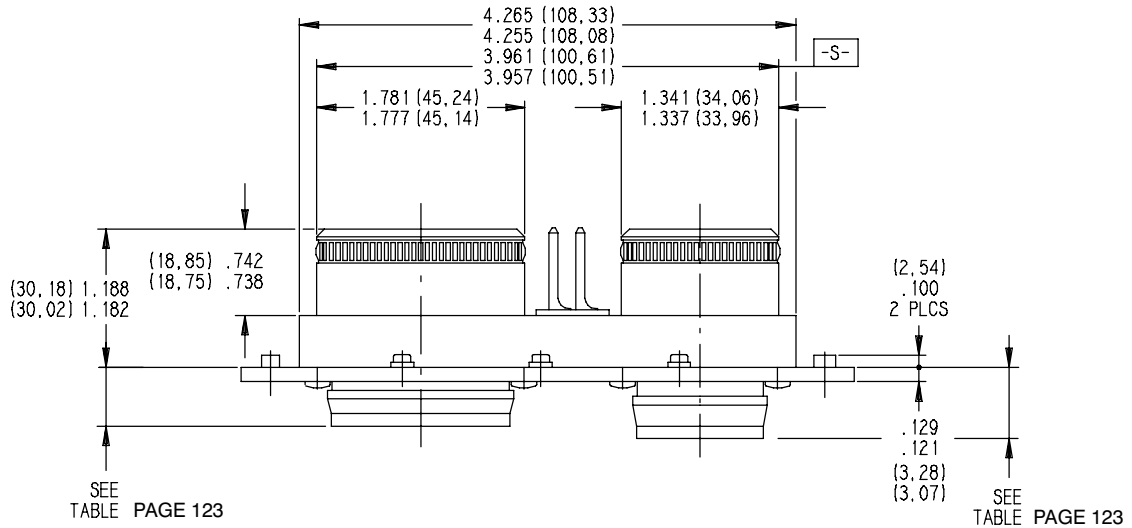

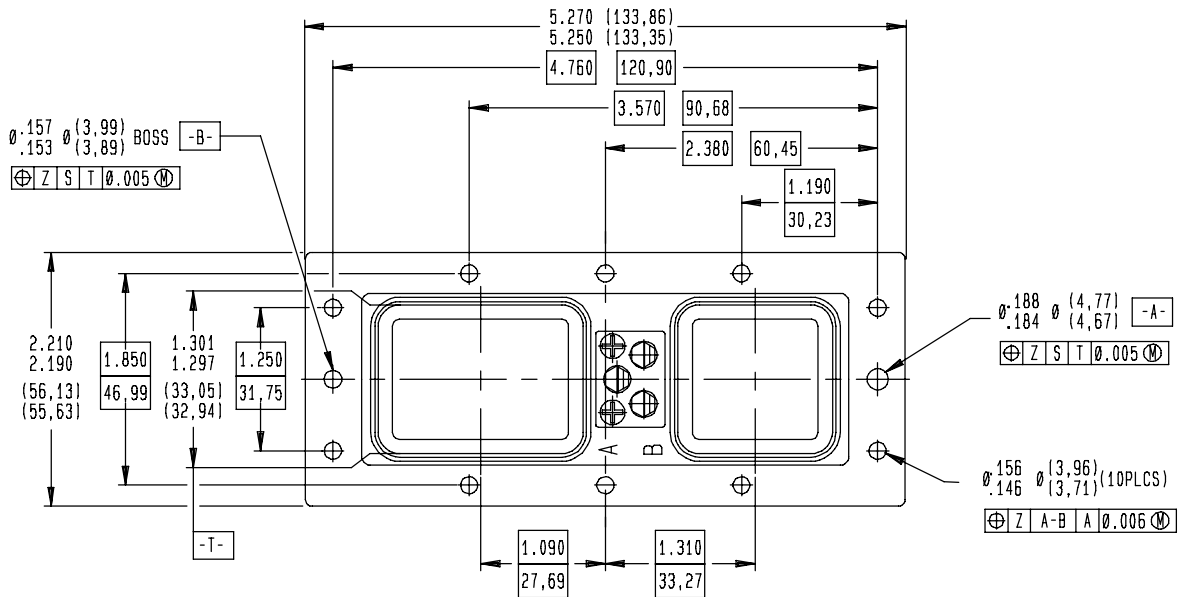
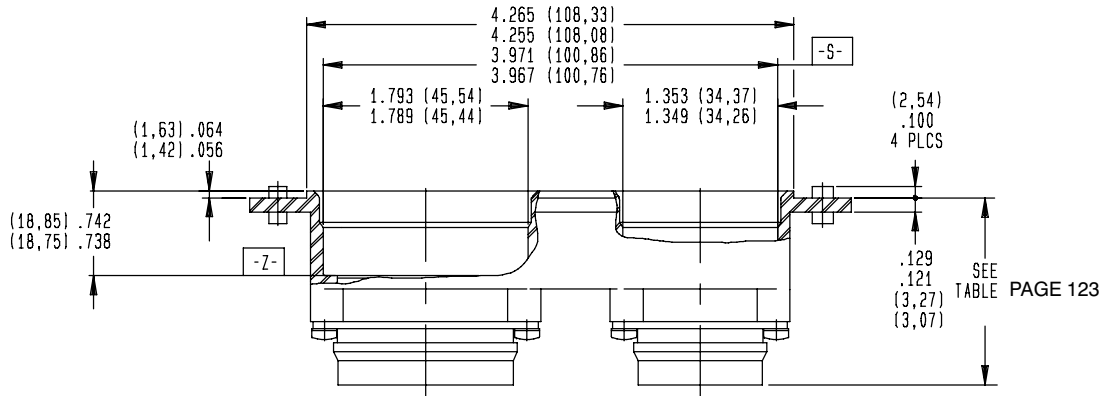

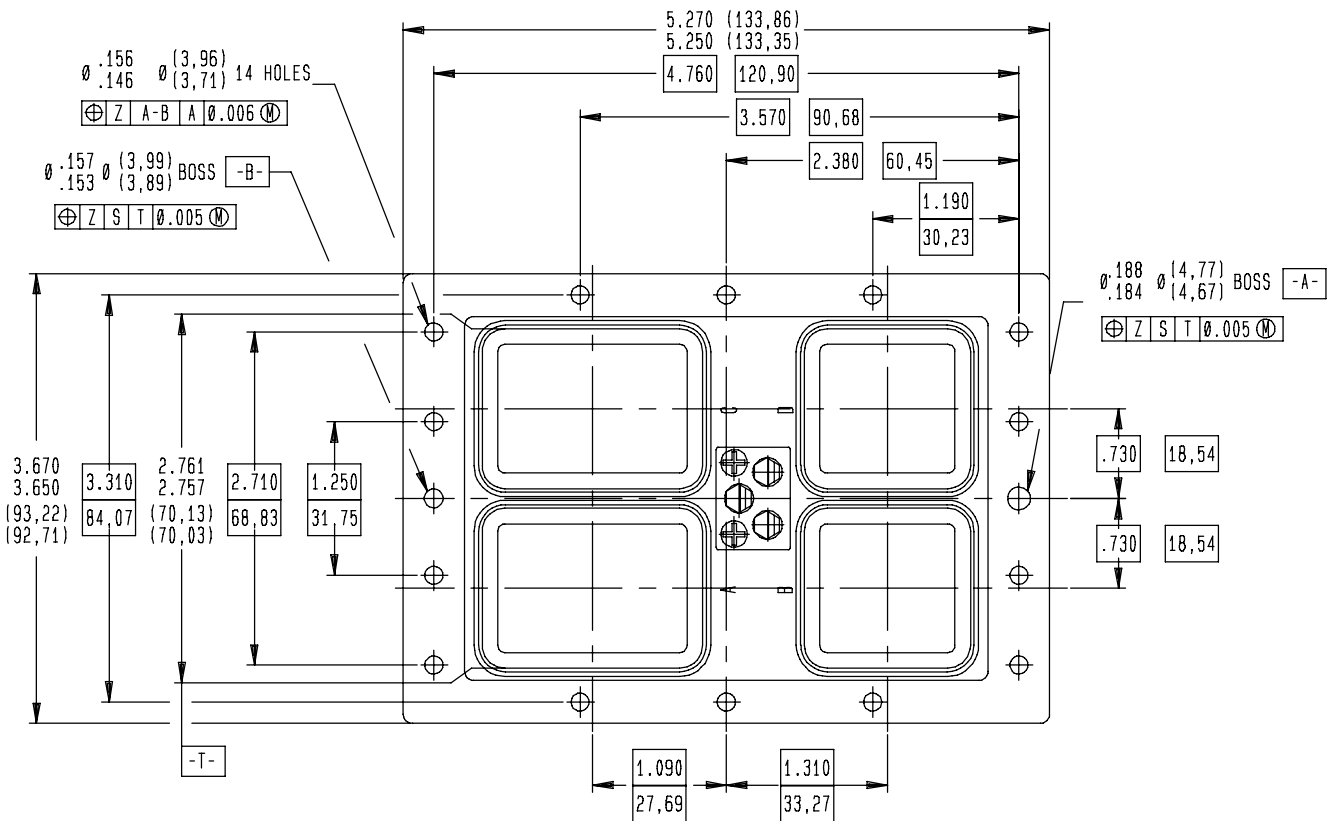
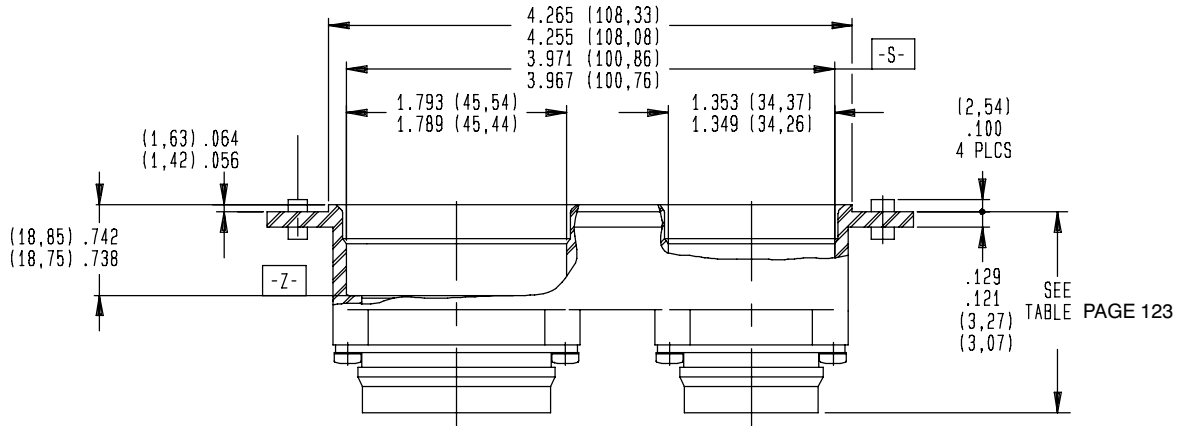

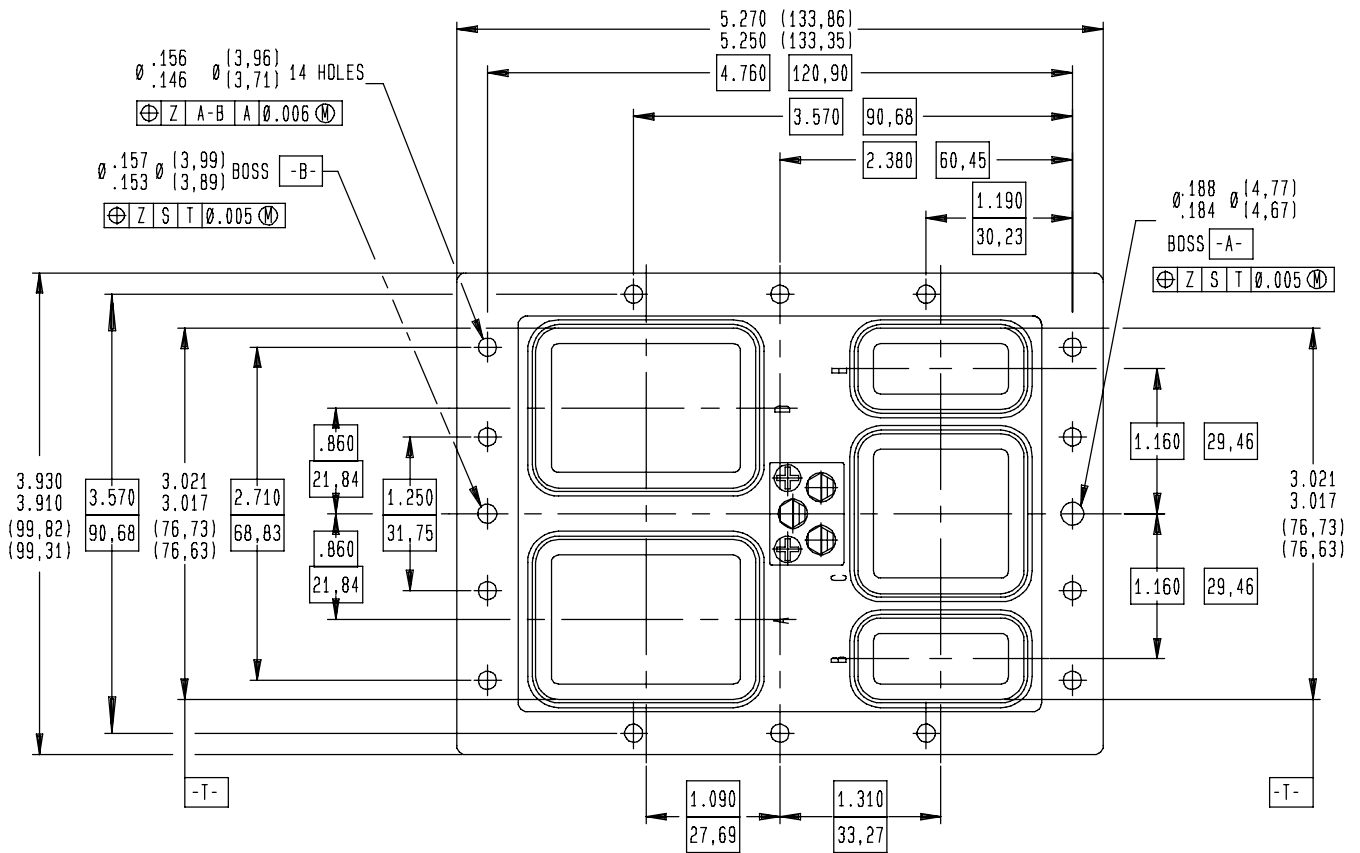
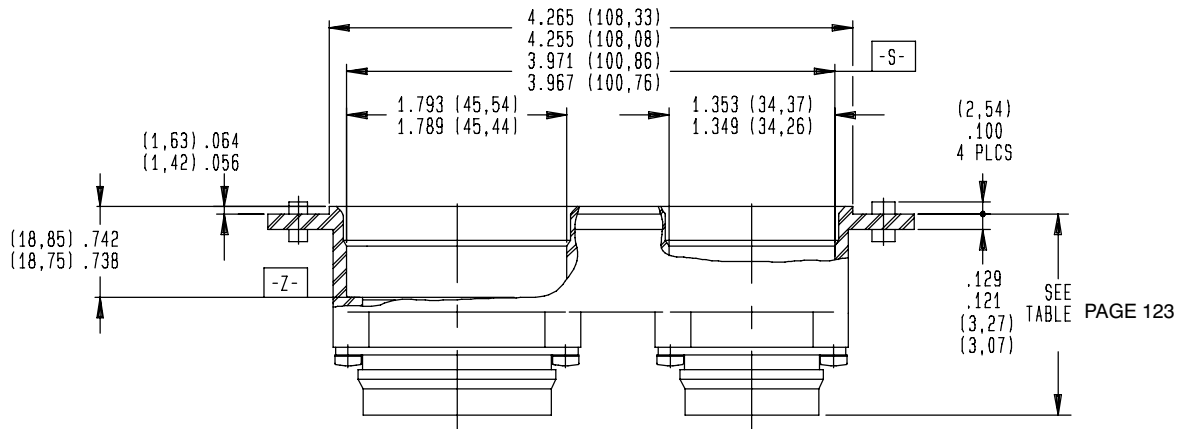

CONTACT ARRANGEMENTS CLASS	Dimensions for plug fitted with insert for size 22 contacts	Dimensions for plug fitted with insert for sizes other than 22 contacts	Dimensions for receptacle fitted with insert for size 22 contacts	Dimensions for receptacle fitted with insert for sizes other than 22 contacts
N	.150 (3.80) max	.150 (3.80) max	1.197 (30.40) max	1.311 (33.30) max
E	.445 (11.30) max	.445 (11.30) max	1.488 (37.80) max	1.658 (42.10) max
F	/	/	1.213 (30.80) max	1.213 (30.80) max

PANEL CUT OUT FOR PLUG

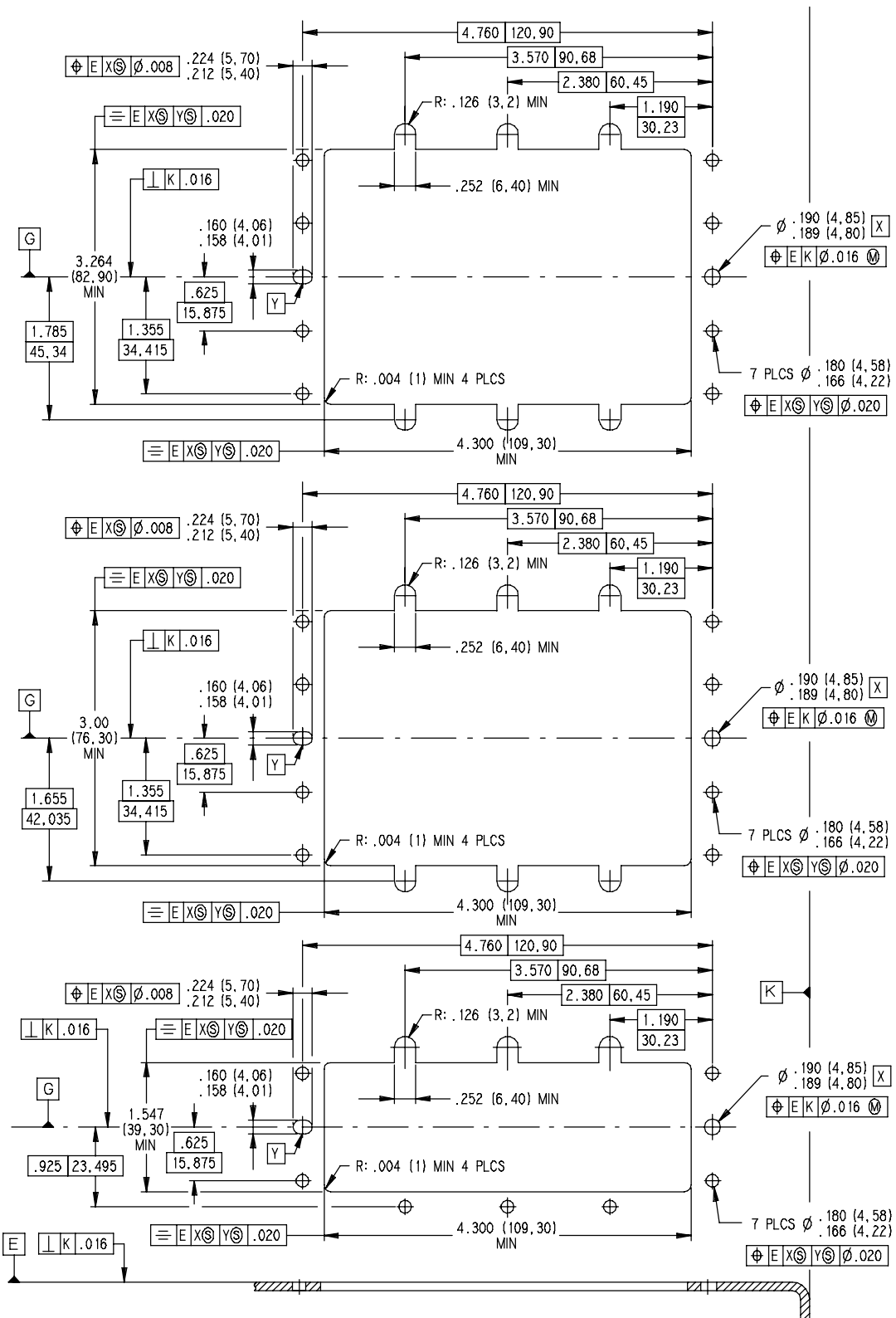

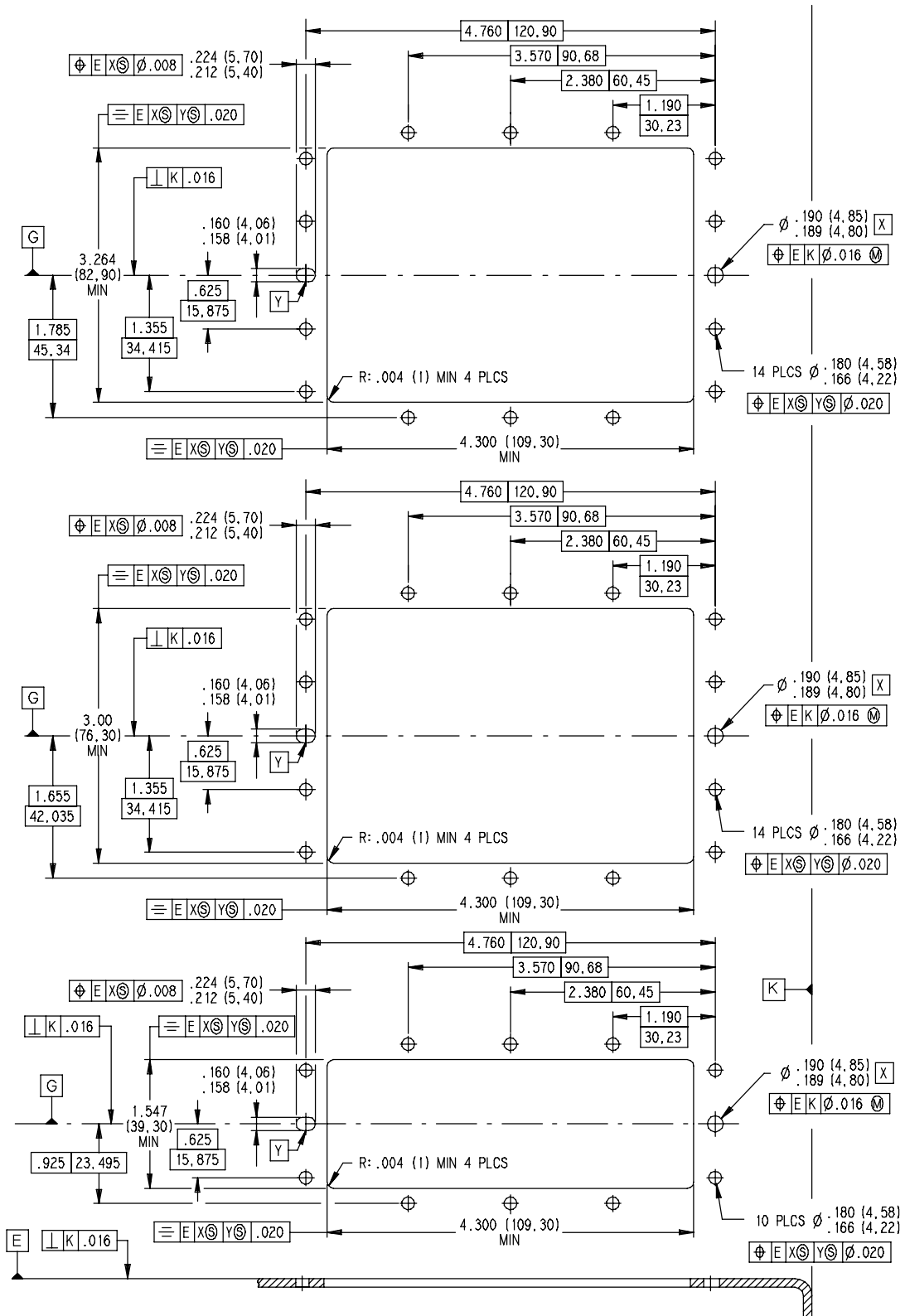

Radiall P/N	Page	Radiall P/N	Page	Radiall P/N	Page
282 236	50, 51, 58, 61	616 911	63	619 153 001	34
282 246	48, 50, 54, 55, 61	616 912	63	619 154	34
282 247	48, 61	616 913	63	619 154 001	34
282 281	25, 28, 29, 49, 51, 54, 55, 56, 57, 61	618 050	40	619 155	35
282 285	25	618 054	40	619 155 001	35
282 291	25, 26, 48, 50, 61	618 149 012	92	619 156	36
282 292	56, 61	618 149 013	92	619 156 001	36
282 293	48, 49, 50, 51, 52, 54, 55, 58, 61	618 149 016	92	619 162 009	93
282 296	27, 48	618 149 017	92	619 162 010	93
282 500	62, 90, 91	618 149 018	92	619 162 011	93
282 503	62, 90	618 150	40	619 162 012	93
282 504	62, 90, 92	618 154	40	619 162 014	93
282 515	25	618 155 001	92	619 162 015	93
282 540 001	27	618 155 002	92	619 162 016	93
282 546	25, 62	618 155 011	92	619 162 017	93
282 547	26, 62	618 160	57	619 165	41
282 548	27, 62	618 161	57	619 165 002	41
282 549 001	27, 33, 34, 35, 41, 42, 62	618 915	64	619 166	41
282 549 004	26, 62	618 953	17	619 169 001	41
282 549 005	62, 91, 92	618 953 001	116	619 240	26
282 549 006	92	618 953 002	115	619 270	27
282 549 009	62, 91, 92, 93	619 030	33	619 271	27
282 549 011	62	619 031	33	619 370	27
282 549 012	27, 33, 41, 62	619 050	35	619 371	27
282 549 028	25	619 051	33	619 950	64
282 549 029	25	619 052	34	619 952	64
282 550	51, 54, 55, 61	619 053	34	619 953	64
282 555	56, 61	619 050 001	35	619 960	41, 69
282 556	56, 61	619 051 001	33	619 960 005	14
282 557	27	619 052 001	34	620 001	30
282 574	57	619 053 001	34	620 001 012	32
282 576	57	619 054	34	620 003	30
282 579	26, 61	619 054 001	34	620 005	31
282 586 001	48	619 054 002	35	620 011	32
282 587	49, 61	619 055	35	620 017	109
282 588	27, 61	619 055 001	35	620 019 105	110
282 885	28, 29, 62	619 056	36	620 020	37
282 886	25, 28, 29, 62	619 056 001	36	620 021	37
282 890	62, 88	619 065	41	620 022	37
282 892	40, 62	619 069 001	41	620 023	38
282 945	62	619 069 002	41	620 024	38
282 946	37, 38, 39, 62	619 130	33	620 026 001	38
282 970	25, 28, 29, 61	619 131	33	620 029	38
282 971	25, 28, 29, 61	619 140 007	92	620 043 001	32
282 972	25, 26, 61	619 140 008	92	620 044	32
282 992	48	619 140 009	92	620 046	48, 110
282 997	48, 50, 61	619 140 010	92	620 047	110
616 095 001	40, 58	619 140 011	92	620 047 010	110
616 095 009	40	619 140 012	92	620 049	109, 110
616 096 004	58	619 140 013	92	620 075 010	42
616 195 001	40, 58	619 140 014	92	620 075 011	42
616 195 009	40	619 150	35	620 075 020	42
616 196 003	58	619 150 001	35	620 075 021	42
616 196 004	58	619 151	33	620 075 050	42
616 261	27	619 151 001	33	620 075 051	42
616 266	27	619 152	34	620 079 001	42
616 361	27	619 152 001	34	620 079 002	42
616 366	27	619 153	34	620 082 001	39
616 910	63			620 083 001	39

Radiall P/N	Page	Radiall P/N	Page	Radiall P/N	Page
620 084	39	620 214 008	90	620 911	65
620 101	30	620 214 010	90	620 912	65
620 101 001	30	620 214 013	90	620 913	65
620 101 003	30	620 214 018	90	620 913 001	65
620 101 004	30	620 214 019	90	620 913 002	65
620 101 011	32	620 214 021	90	620 913 003	65
620 101 012	32	620 214 022	90	620 913 004	65
620 103	30	620 230	25	620 919	63
620 107	31	620 231	25	620 920	63
620 107 001	31	620 234 003	90	620 921	63
620 108	31, 48	620 234 004	90	620 922	63
620 108 001	31, 48	620 234 008	90	620 923	63
620 109	31, 48	620 234 017	90	620 924	64
620 109 001	31, 48	620 234 018	90	620 925	64
620 116	109	620 234 019	90	620 926	63
620 117	48, 109	620 234 021	90	620 936 001	63
620 119 100	109	620 234 022	90	620 936 002	64
620 119 102	48, 109	620 240	26	620 937 001	64
620 119 105	110	620 241	26	620 940	68
620 120	37	620 244 003	91	620 941	68
620 121	37	620 244 005	91	620 942	68
620 122	37	620 244 008	91	620 995 001	67
620 123	38	620 244 016	91	620 995 002	67, 117
620 124	38	620 244 018	91	620 995 003	66
620 126 001	38	620 244 019	91	620 995 004	66, 115
620 129	38	620 244 021	91	620 995 005	67
620 133 001	92	620 244 022	91	620 995 006	67, 117
620 133 006	92	620 280	28	620 995 007	66, 115
620 133 009	92	620 281	29	620 995 008	66, 115
620 134	39	620 290	28	620 995 009	67
620 145	48, 109	620 291	29	620 995 010	67
620 146	109	620 300	25	620 995 011	66
620 147	48, 109	620 301	25	620 995 012	66, 116
620 148	48, 109, 110	620 302	88	620 995 013	67
620 149	109, 110	620 303	88	620 995 014	67
620 175 010	42	620 305	88	620 995 015	66
620 175 011	42	620 305 005	88	620 995 016	66, 116
620 175 020	42	620 308	88	620 995 017	67, 117
620 175 021	42	620 310	25	620 995 018	67, 116
620 175 050	42	620 330	25	670 150	57
620 175 051	42	620 331	25	670 151	57
620 176 008	91, 93	620 340	26	925 05 552	69
620 176 009	91, 93	620 341	26	925 05 553	69
620 176 010	91, 93	620 350	91	925 05 554	69
620 176 011	91, 93	620 351	91	925 05 560	64
620 176 012	91, 93	620 352	91		
620 176 013	91, 93	620 353	91		
620 176 014	91, 93	620 360	90		
620 176 016	91, 93	620 360 005	90		
620 179 001	42	620 361	90		
620 179 002	42	620 361 005	90		
620 182 001	39	620 362	90		
620 183 001	39	620 362 005	90		
620 184	39	620 363	90		
620 200	25	620 363 005	90		
620 201	25	620 380	28		
620 202	88	620 381	29		
620 202 005	88	620 390	28		
620 210	25	620 391	29		
620 214 003	90	620 910	65		



AEROSPACE



AUTOMOTIVE



DEFENSE



INDUSTRIAL



INSTRUMENTATION



MEDICAL



SPACE



TELECOM

EUROPE

France - RADIALL Headquarters

101, Rue Ph. Hoffmann
93116 ROSNY sous BOIS (Paris)
Tel.: +33 1 49 35 35 35 - Fax: +33 1 48 54 63 63
E-Mail: info@radiall.com

Finland - RADIALL SF

P.O. Box 202 - 90101 OULU
Tel.: +358 407 522 412
E-Mail: infofi@radiall.com

Germany - RADIALL GmbH

Carl-Zeiss Str. 10 Postfach 200143
D63307 - RÖDERMARK (Frankfurt)
Tel.: +49 60 74 91 07 0 - Fax: +49 60 74 91 07 70
E-Mail: infode@radiall.com

Italy - RADIALL Elettronica S.R.L.

Via Concordia, 5 - 20090 ASSAGO MILANO
Tel.: +39 02 48 85 121 - Fax: +39 02 48 84 30 18
E-Mail: infoit@radiall.com
Regional office: Roma

Netherlands - RADIALL B.V.

Hogebrinkerweg 15b - 3871 KM HOEVELAKEN
Tel.: +31 33 253 40 09 - Fax: +31 33 253 45 12
E-Mail: infonl@radiall.com

Sweden - RADIALL A.B.

Sjöängsvägen 2 - SE-192 72 SOLLENTUNA (Stockholm)
Tel.: +46 844 434 10 - Fax: +46 875 449 16
E-Mail: infose@radiall.com

U.K. - RADIALL Ltd

Ground Floor, 6 The Grand Union Office Park,
Packet Boat Lane
UXBRIDGE Middlesex UB8 2GH (London)
Tel.: +44 1895 425 000 - Fax: +44 1895 425 010
E-Mail: infouk@radiall.com

NORTH AMERICA

USA - RADIALL USA, Inc.

6825 West Galveston Street Suite 11
CHANDLER, Arizona 85226
Tel.: +1 480 682 9400 - Fax: +1 480 682 9403
E-Mail: infousa@radiall.com

USA - RADIALL AEP, Inc.

104 John W. Murphy Drive
NEW HAVEN, Connecticut 06513
Tel.: +1 203 776 2813 - Fax: +1 203 776 8294
E-Mail: aeppsales@radiall.com

ASIA

China - SHANGHAI RADIALL Electronic Co., Ltd

N° 390 Yong He Road 200072 - SHANGHAI
Tel.: +86 21 66 52 37 88 - Fax: +86 21 66 52 11 77
E-Mail: infosh@radiall.com

Japan - NIHON RADIALL

Shibuya-ku Ebisu 1-5-2, Kougetsu Bldg 405
TOKYO 150-0013
Tel.: +81 3 3440 6241 - Fax: +81 3 3440 6242
E-Mail: infojp@radiall.com

HongKong - RADIALL Electronics Ltd

Elite Industrial Centre, Room 212, 2/F
N° 883 Cheung Sha Wan Road
KOWLOON HONG KONG
Tel.: +852 29 59 38 33 - Fax: +852 29 59 26 36
E-Mail: infohk@radiall.com

India - RADIALL PROTECTRON pvt Ltd

25 D, II Phase, Peenya Industrial Area
BANGALORE 560058
Tel.: +91 80 83 95 271 - Fax: +91 80 83 97 228
E-Mail: infoin@radiall.com

ALSO REPRESENTED IN

Australia	Hungary	Poland
Austria	Indonesia	Russia
Belgium	Israel	Singapore
Brazil	Korea	Spain
Czech Republic	Latvia	Switzerland
Denmark	Lithuania	Taiwan
Estonia	Malaysia	Thailand
Greece	Norway	Vietnam
	Philippines	South Africa

For the above countries, please contact the local agent or RADIALL at info@radiall.com