



## UF200 ~ UF2010

### ULTRAFAST SWITCHING RECTIFIER

**VOLTAGE** 50 to 1000 Volts **CURRENT** 2.0 Amperes

**DO-15** Unit: inch(mm)

#### FEATURES

- Plastic package has Underwriters Laboratory Flammability Classification 94V-O utilizing Flame Retardant Epoxy Molding Compound
- Exceeds environmental standards of MIL-S-19500/228.
- Ultra Fast switching for high efficiency.
- In compliance with EU RoHS 2002/95/EC directives

#### MECHANICAL DATA

- Case: Molded plastic, DO-15
- Terminals: Axial leads, solderable per MIL-STD-750, Method 2026
- Polarity: Band denotes cathode
- Mounting Position: Any
- Weight: 0.014 ounce, 0.397 gram

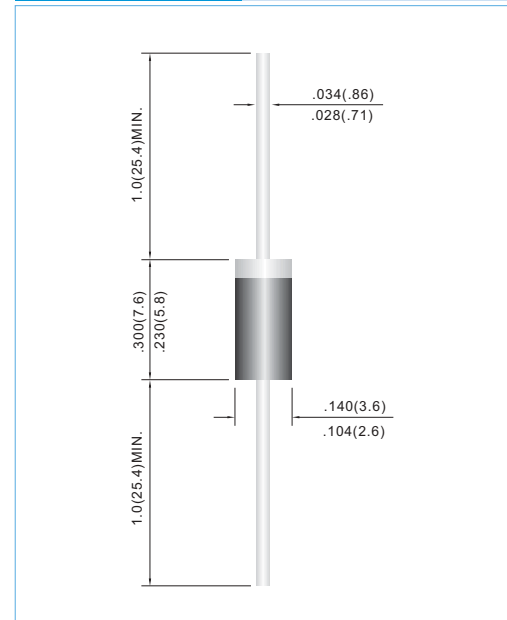

### MAXIMUM RATINGS AND ELECTRICAL CHARACTERISTICS

Ratings at 25°C ambient temperature unless otherwise specified. Resistive or inductive load, 60Hz.

PARAMETER	SYMBOL	UF200	UF201	UF202	UF204	UF206	UF208	UF2010	UNITS	
Maximum Recurrent Peak Reverse Voltage	$V_{RRM}$	50	100	200	400	600	800	1000	V	
Maximum RMS Voltage	$V_{RMS}$	35	70	140	280	420	560	700	V	
Maximum DC Blocking Voltage	$V_{DC}$	50	100	200	400	600	800	1000	V	
Maximum Average Forward Current at $T_A=55^\circ\text{C}$	$I_{F(AV)}$	2.0							A	
Peak Forward Surge Current : 8.3ms single half sine-wave superimposed on rated load (JEDEC method)	$I_{FSM}$	60							A	
Maximum Forward Voltage at 2.0A	$V_F$	1.0		1.3		1.7			V	
Maximum DC Reverse Current at $T_J=25^\circ\text{C}$ Rated DC Blocking Voltage $T_J=100^\circ\text{C}$	$I_R$	10.0				500				$\mu\text{A}$
Typical Junction capacitance (Note 1)	$C_J$	35							pF	
Typical Thermal Resistance (Note 2)	$R_{\theta JA}$	40							$^\circ\text{C} / \text{W}$	
Maximum Reverse Recovery Time (Note 3)	$t_{rr}$	50				75				ns
Operating Junction and Storage Temperature Range	$T_J, T_{STG}$	-55 to +150							$^\circ\text{C}$	

#### NOTES:

1. Measured at 1 MHz and applied reverse voltage of 4.0 VDC.
2. Thermal Resistance from Junction to Ambient and from Junction to lead length 0.375"(9.5mm) P.C.B. mounted.
3. Reverse Recovery Time  $I_F=.5\text{A}$ ,  $I_R=1\text{A}$ ,  $I_{rr}=.25\text{A}$



# UF200 ~ UF2010

## RATING AND CHARACTERISTIC CURVES

