

# EE040

## OEM Humidity and Temperature Sensor

The EE040 is dedicated for cost effective measurement of the relative humidity (RH) and temperature (T) in OEM applications. It employs the high quality EEH210 RH and T sensing element, which stands for reliable and long term stable measurement performance.

The electronics board and the components are protected by a special varnish. In addition, the proprietary E+E coating protects the RH sensor against dirt, dust and corrosion, which leads to excellent long-term stability even in polluted environment.

The measured data is available on two analogue voltage outputs.

The EE040 design, the plug connection and the mounting flange included in the scope of supply facilitate the design-in, installation and replacement.



Model T18

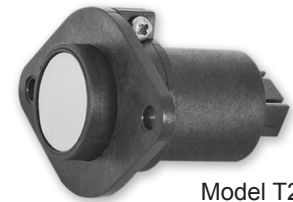

Model T2

### Features

- Compact design
- Easy installation and replacement
- Excellent price / performance ratio

### Technical Data

#### Measurands

##### Relative Humidity

Working range	0...100 % RH	
Accuracy <sup>1)</sup> at 20 °C (68 °F)	± 3 % RH (30...70 % RH)	± 5 % RH (0...95 % RH)
Output signal (0...100 %)	0 - 2.5 V	
Output load	≥ 5 kΩ	
Response time $\tau_{63}$	< 45 s duct mount < 30 s duct mount with lateral openings	

##### Temperature

Output signal	0 - 2.5 V	
Output load	≥ 5 kΩ	
Accuracy <sup>1)</sup> at 20 °C (68 °F)	± 0.3 °C (0.54 °F)	

#### General Data

Supply voltage $U_v$	5 V DC ±10 %	
Current consumption	typical 2 mA without load < 3.5 mA at 5 kΩ load	
Start up time	typ. 4 sec.	
Electrical connection	appropriate for Molex 6471 (4 pins) and female crimp contacts 4809 555L	
Housing material	PPO – GF20, UL94HB approved	
Protection class	connector side: IP30 front side: IP50 (duct mount) IP20 (duct mount with lateral openings)	
CE compatibility according <sup>2)</sup>	EN61326-1	EN61326-2-3
	Industrial environment	
Working conditions	T = -40...+85 °C (-40...185 °F) RH = 0...100 % (non condensing)	
Storage conditions	T = -40...+60 °C (-40...140 °F) RH = 0...95 % (non condensing)	



1) Traceable to intern. standards, administrated by NIST, PTB, BEV... . The accuracy statement includes the uncertainty of the factory calibration with an enhancement factor k=2 (2-times standard deviation). The accuracy was calculated in accordance with EA-4/02 and with regard to GUM (Guide to the Expression of Uncertainty in Measurement).

2) EE040 is not protected against surge

## Protective Sensor Coating

The E+E proprietary sensor coating is a protective layer applied to the active surface of the sensing element.

The coating substantially extends the lifetime and the measurement performance of the E+E sensor in corrosive environment. Additionally, it improves the sensor's long term stability in dusty or dirty applications by preventing stray impedances caused by deposits on the active sensor surface.

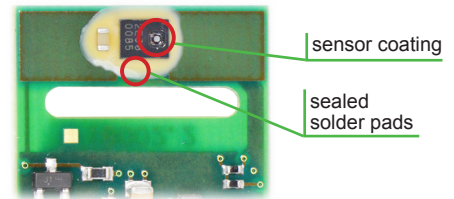

EEH210 RH and T  
sensing element

## Dimensions (mm/inch)

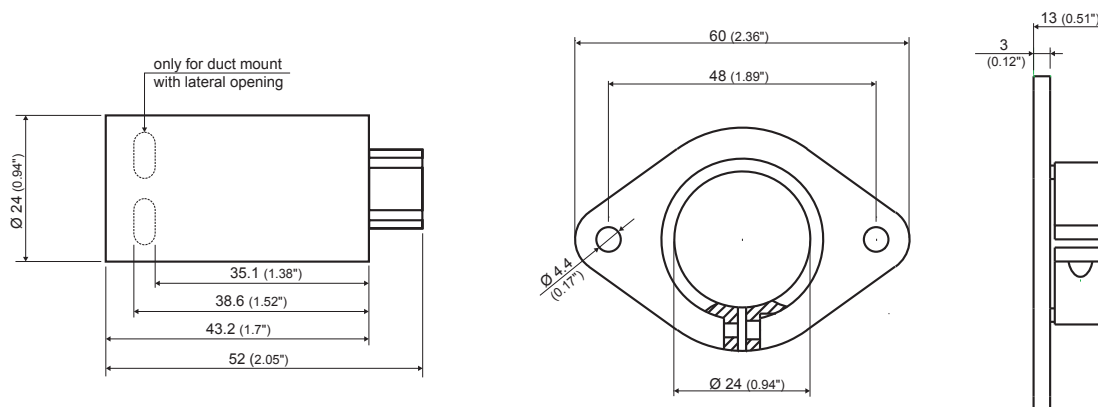

## Ordering Guide

		EE040-
<b>Model</b>	duct mount	T2
	duct mount with lateral openings	T18
<b>Filter</b>	plastic grid, no filter	F1
	metal grid filter	F3
<b>Output signal</b>	0 - 2.5 V	no code
<b>Output 1</b>	relative humidity (0...100 % RH)	no code
<b>Output 2</b>	temperature [°C]	no code
	temperature [°F]	MB2
<b>Scaling output 2 low</b>	0	no code
	value	SBL value
<b>Scaling output 2 high</b>	50	no code
	value	SBH value

## Order Example

### EE040-T18F3SBL-20SBH40

Type: duct mount with lateral openings  
 Filter: metal grid filter  
 Output signal: 0 - 2.5 V  
 Output 1: relative humidity (0...100 % RH)  
 Output 2: temperature [°C]  
 Scaling output 2 low: -20 °C  
 Scaling output 2 high: 40 °C

Connection cable 2 m (6.6 ft) (HA010305)  
 5 m (16.4 ft) (HA010306)

## Accessories