

Zinc Oxide Varistor TVR Type
Part No. :TVR10471KLM

REVISED RECORD SHEET

REV. NO	REV. DATE	REVISED CONTENT

INDEX	Page
■ Part Number Code	1
■ Structure and Dimensions	2
■ Electrical Characteristics	2
■ Reliability	3 ~ 4
■ Soldering Recommendation	5
■ Power Derating Curve	6
■ RoHS Compliant Declaration	6
■ Warehouse Storage Conditions of Products	6
■ Safety Approvals	7
■ Certificates	7
■ Max. Surge Current Derating Curves	8
■ Max. Leakage Current and Max. Clamping Voltage Curve	9

Part Number Code

Example :

TVR **10** **471** **K** **L** **M**
 (1) (2) (3) (4) (5) (6)

No.	Item	Digit	Specification
(1)	Product Type	TVR	Thinking varistor TVR type
(2)	Body Size	10	φ10 mm
(3)	Varistor Voltage	471	$47 \times 10^1 \text{ V} = 470\text{V} (V_{1\text{mA}})$
(4)	Tolerance of $V_{1\text{mA}}$	K	±10%
(5)	Appearance	L	Straight lead, Silicon Coating
(6)	Optional Suffix	M	RoHS+HF compliance

Structure and Dimensions

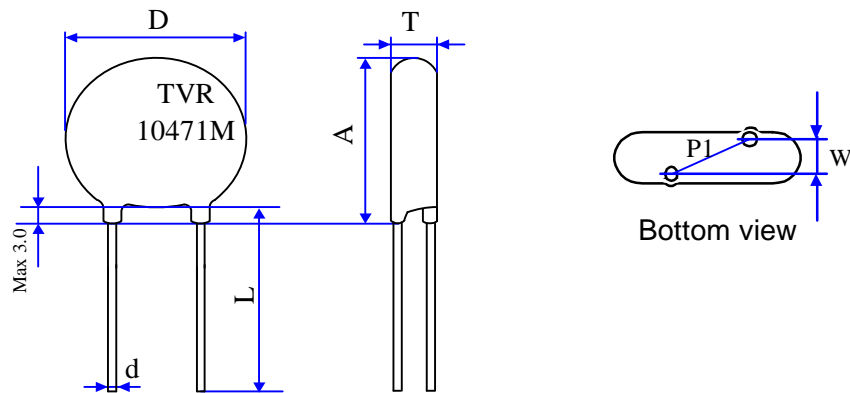

(unit : mm)

Body Size	D	P 1	d	A max.	L min.	T	W
φ 10	11~14.4	7.5±1	0.80±0.05	15.0	25	4.64~6.76	2.6±1.0

***Coating material rating:UL 94 V-0**

Electrical Characteristics (Ambient Ta=25 °C)

Part No.	Varistor Voltage (@ 1mA DC)	Max. Continuous Voltage		Max. Clamping Voltage (8/20μS)		Max. Surge Current (8/20μS)	Max. Energy (10/1000μS)
	V _{1mA} (V)	V _{AC} (rms) (V)	V _{DC} (V)	V _p (V)	I _p (A)	I (A)	W (J)
TVR10471KLM	470 ± 10 %	300	385	775	25	3500	85

Part No.	Rated Power	Impulse Response Time	Max. Leakage Current at 75%V _{1mA}	Operating Temperature Range	Storage temperature Range	Applications		
	P (W)	nSec	I _L (μA)	(°C)	(°C)	UL 1449	IEC 60950-1	IEC 60065
TVR10471KLM	0.4	<25	20	-40 ~ +125	-40 ~ +150	SPD Type 5	Annex Q	Clause 14.12

The mechanical force acted on the wire lead may cause cracks and chips of the coating ,but which does not affect the performance of the component

Reliability

Item	Standard	Test conditions / Methods	Specifications															
Tensile Strength of Terminals	IEC60068-2-21	<p>Gradually applying the force specified and keeping the unit fixed for 10±1 sec.</p> <table border="1"> <thead> <tr> <th>Terminal diameter (mm)</th> <th>Force (Kg)</th> </tr> </thead> <tbody> <tr> <td>0.5<d≤0.8</td> <td>1.0</td> </tr> <tr> <td>0.8<d≤1.25</td> <td>2.0</td> </tr> <tr> <td>1.25<d</td> <td>4.0</td> </tr> </tbody> </table>	Terminal diameter (mm)	Force (Kg)	0.5<d≤0.8	1.0	0.8<d≤1.25	2.0	1.25<d	4.0	<p>No visible damage ΔV/V_{1mA} ≤5%</p>							
Terminal diameter (mm)	Force (Kg)																	
0.5<d≤0.8	1.0																	
0.8<d≤1.25	2.0																	
1.25<d	4.0																	
Bending Strength of Terminals	IEC60068-2-21	<p>Hold specimen and apply the force specified below to each lead. Bend the specimen to 90°, then return to the original position. Repeat the procedure in the opposite direction.</p> <table border="1"> <thead> <tr> <th>Terminal diameter (mm)</th> <th>Force (Kg)</th> </tr> </thead> <tbody> <tr> <td>0.5<d≤0.8</td> <td>0.5</td> </tr> <tr> <td>0.8<d≤1.25</td> <td>1.0</td> </tr> <tr> <td>1.25<d</td> <td>2.0</td> </tr> </tbody> </table>	Terminal diameter (mm)	Force (Kg)	0.5<d≤0.8	0.5	0.8<d≤1.25	1.0	1.25<d	2.0	<p> ΔV/V_{1mA} ≤5%</p>							
Terminal diameter (mm)	Force (Kg)																	
0.5<d≤0.8	0.5																	
0.8<d≤1.25	1.0																	
1.25<d	2.0																	
Vibration	IEC 60068-2-6	<p>Frequency range:10~55Hz Amplitude:0.75mm or 98m/S² Direction:3 mutually perpendicular directions,2hrs each.</p>	<p> ΔV/V_{1mA} ≤5% No visible damage</p>															
Solderability	IEC60068-2-20	245 ± 3 °C , 3 ± 0.3 sec	At least 95% of terminal electrode is covered by new solder															
Resistance to Soldering Heat	IEC60068-2-20	260 ± 3 °C , 10 ± 1 sec	<p>No visible damage ΔV/V_{1mA} ≤5%</p>															
High Temperature Storage	IEC60068-2-2	150 ± 5 °C , 1000 ± 24 hrs	<p>No visible damage ΔV/V_{1mA} ≤5%</p>															
Damp Heat, Steady State	IEC 60068-2-78	<p>The test is divided into two groups . a.40 ± 2°C , 90 ~ 95 % RH , 1344 hrs b.40 ± 2°C , 90 ~ 95 % RH , at 10%V_{DC}, 1344 hrs</p>	<p>No visible damage ΔV/V_{1mA} ≤10% Insulation Resistance ≥ 100MΩ</p>															
Rapid Change of Temperature	IEC60068-2-14	<p>The conditions shown below shall be repeated 1000 cycles</p> <table border="1"> <thead> <tr> <th>Step</th> <th>Temperature (°C)</th> <th>Period (minutes)</th> </tr> </thead> <tbody> <tr> <td>1</td> <td>-40 ± 3</td> <td>30 ± 3</td> </tr> <tr> <td>2</td> <td>Room temperature</td> <td>5 ± 3</td> </tr> <tr> <td>3</td> <td>125 ± 2</td> <td>30 ± 3</td> </tr> <tr> <td>4</td> <td>Room temperature</td> <td>5 ± 3</td> </tr> </tbody> </table>	Step	Temperature (°C)	Period (minutes)	1	-40 ± 3	30 ± 3	2	Room temperature	5 ± 3	3	125 ± 2	30 ± 3	4	Room temperature	5 ± 3	<p>No visible damage ΔV/V_{1mA} ≤5%</p>
Step	Temperature (°C)	Period (minutes)																
1	-40 ± 3	30 ± 3																
2	Room temperature	5 ± 3																
3	125 ± 2	30 ± 3																
4	Room temperature	5 ± 3																
High Temp. Load	MIL-STD-202 Method 108	125 ± 2 °C , 1000 ± 24 hrs, at V _{DC} or V _{rms} (Max. Operating Voltage)	<p> ΔV/V_{1mA} ≤10% No visible damage</p>															
Flammability test	Specification Standard	<p>The varistor shall be subjected to 60sec.applications of test flame. Burner:Bunsen gas burner 9000kcal/m³ Diameter of flame nozzle: Φ9.5mm Position : the specimen shall be fixed horizontal Point of application shall be approximately center of the specimen</p>	<p>No catching fire,and no flaming drops</p>															

Item	Standard	Test conditions / Methods	Specifications
8/20 μ S Surge Life	IEC 61051-1 4.6	10,000 pulses(8/20 μ S) , unipolar, interval 10 secs, amplitude corr. to max. Surge current derating curves for 20 μ S	$ \Delta V/V_{1mA} \leq 10\%$ No visible damage
10/1000 μ S Surge Life	IEC 61051-1 4.6	10/1000 μ S waveform, 10 surge currents,unipolar,interval 2mins, amplitude corr. to max. surge current derating curves for 1000 μ S	$ \Delta V/V_{1mA} \leq 10\%$ No visible damage
Varistor Voltage Temp. Coefficient	Specification Standard	$\frac{V_{1mA} \text{ at } 125^{\circ}\text{C} - V_{1mA} \text{ at } 25^{\circ}\text{C}}{V_{1mA} \text{ at } 25^{\circ}\text{C}} \times \frac{1}{100} \times 100 (\% / ^{\circ}\text{C})$ $\frac{V_{1mA} \text{ at } -40^{\circ}\text{C} - V_{1mA} \text{ at } 25^{\circ}\text{C}}{V_{1mA} \text{ at } 25^{\circ}\text{C}} \times \frac{1}{65} \times 100 (\% / ^{\circ}\text{C})$	$-0.05 \leq TC \leq 0.05(\%/^{\circ}\text{C})$
Voltage Proof	IEC 61051-1 4.9	Metal balls method, 1000 Vac 1 min	No visible damage

Soldering Recommendation

■ Wave Soldering Profile

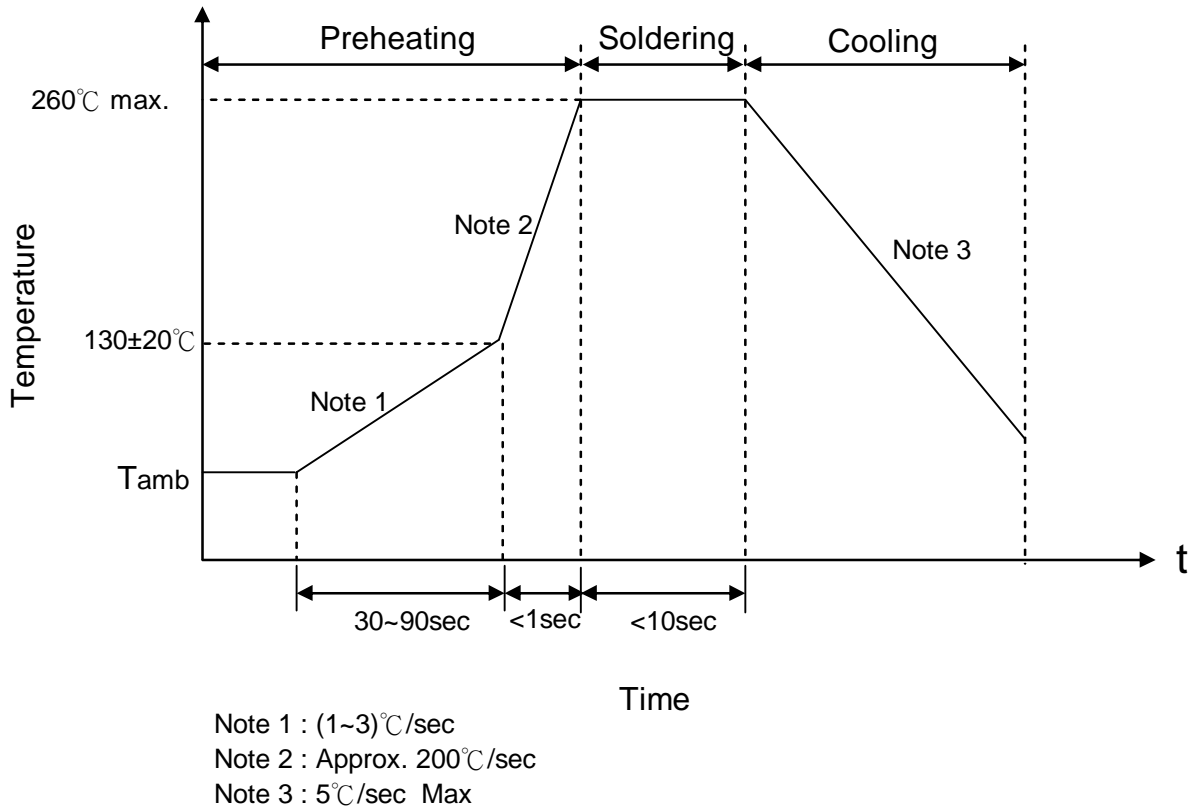

■ Recommended Reworking Conditions with Soldering Iron

Item	Conditions
Temperature of Soldering Iron-tip	360°C (max.)
Soldering Time	3 sec (max.)
Distance from Varistor	2 mm (min.)

Power Derating Curve

When operating temperature exceeds 125°C , the power, the Max.continuous operation Voltage, the Max.Surge Current and the Max.Energy should be derated as below figure, the derated coefficient is -4%.

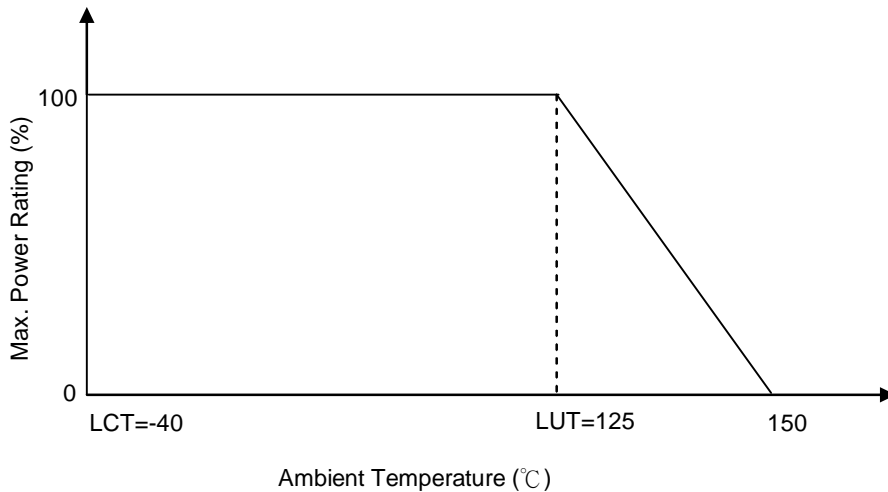

RoHS Compliant Declaration

We hereby declare that the components delivered to your company are compliant with RoHS directive 2011/65/EU.

Warehouse Storage Conditions of Products

(I) Storage Conditions :

- 1.Storage Temperature : $-10^{\circ}\text{C} \sim +40^{\circ}\text{C}$
- 2.Relative Humidity : $\leq 75\% \text{RH}$
- 3.Keep away from corrosive atmosphere and sunlight.

(II) Period of Storage : 1 year

Safety Approvals (Certified Model/Type:TVR10471-M)



- * UL 1449 4th / cUL recognized (File # E314979)
- UL1449 (file number E314979) for use in SPD Type 5



- * VDE DIN EN 61051-1:2009-04 / IEC 61051-1:2007
- IEC 61051-2-2:1991/IEC 60950-1:2013 Annex Q recognized (File # 40036061)



- * CQC GB/T10193-1997 \ GB/T10194-1997 recognized (File # CQC13001090357/CQC13001090356)

Certificates

- (1) TS 16949 certificate
- (2) ISO 9001 certificate

Test Report

- (1) RoHS test report
- (2) Halogen-free test report

Max. Surge Current Derating Curves

TVR10471KLM

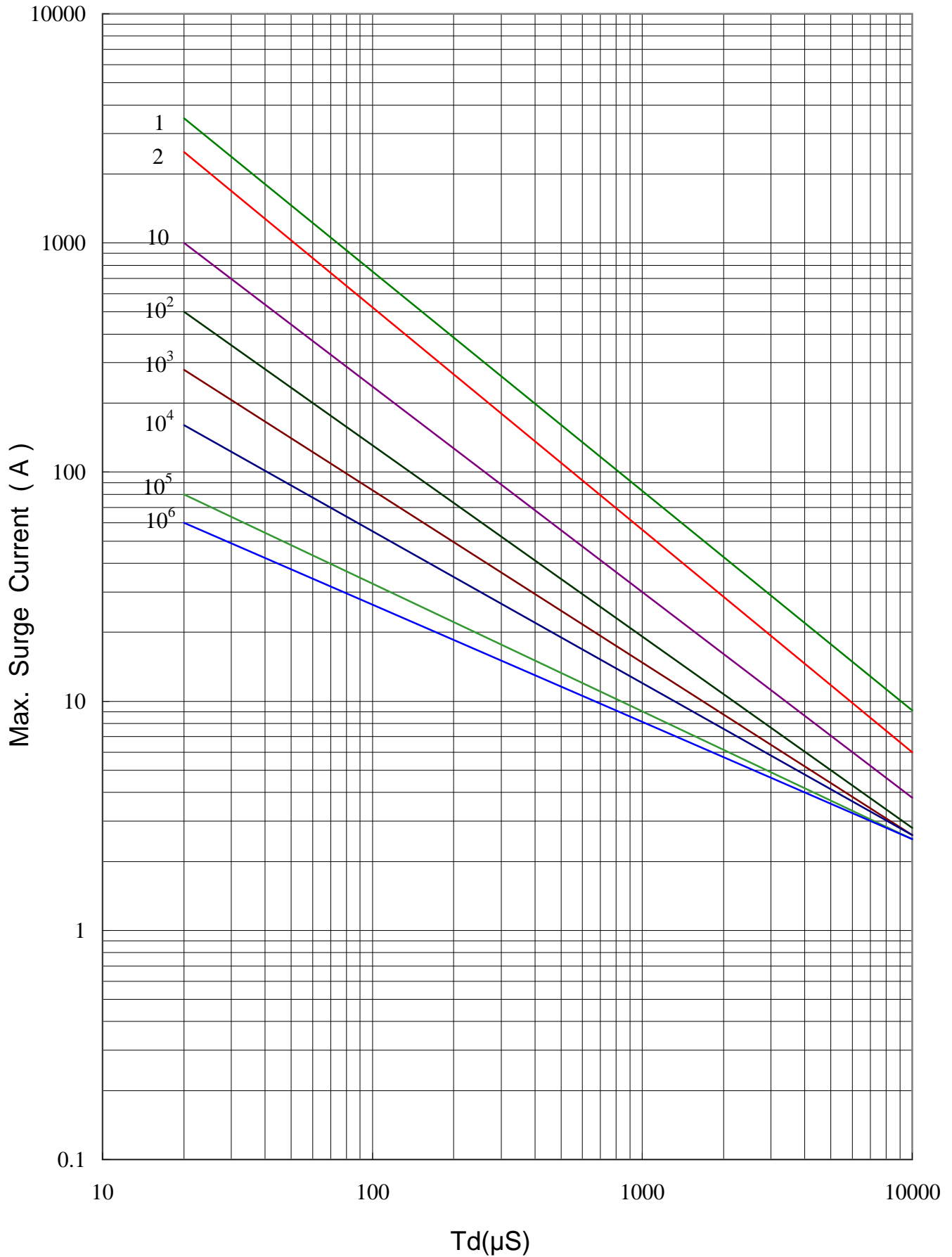

Max. Leakage Current and Max. Clamping Voltage Curve

TVR10471KLM

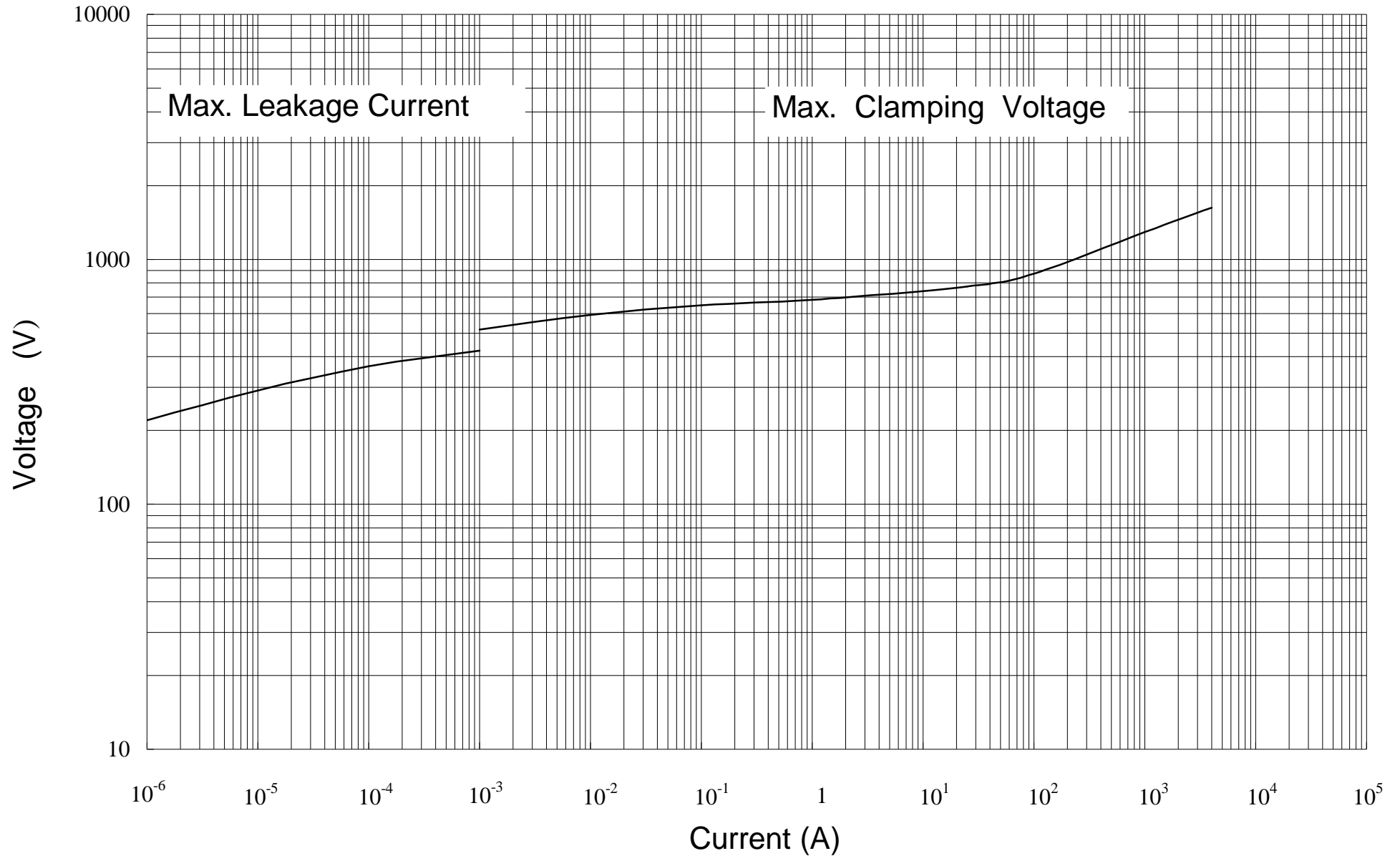

壓敏電阻產品外觀覆蓋塗料材質說明

- 1, 本公司壓敏電阻產品外觀覆蓋塗料材質是由一種具有活性矽樹脂(ACTIVE SILICONE)塗料所組成, 此種塗料已在壓敏電阻上使用超過50年, 具有特殊的優點, 其特性說明如下:
 - A: 絕緣性佳
 - B: 耐高溫(超過300°C)
 - C: 散熱速度快
 - D: 對二次開機尤其具有保護作用
 - E: 此塗料具有無可替代性
- 2, 此塗料材質相當堅固, 但是韌性較差, 如果受不當外力的情況下, (如: 搬運重摔, 將引腳向外掰, 插PCB孔徑與壓敏電阻腳距不匹配, 作用力不當的掰引或彎腳)可能會使產品產生腳裂的現象。
- 3, 同時, 因為矽樹脂的材料特性, 產品在運輸的過程中, 本體因為摩擦易出現摩擦痕跡現象, 但易人工擦除, 且此種現象完全不影響產品特性。
4. 故, 此種輕微腳裂及擦痕現象, 經品保試驗絕對不會影響產品本身的特性, 敬請放心使用。