

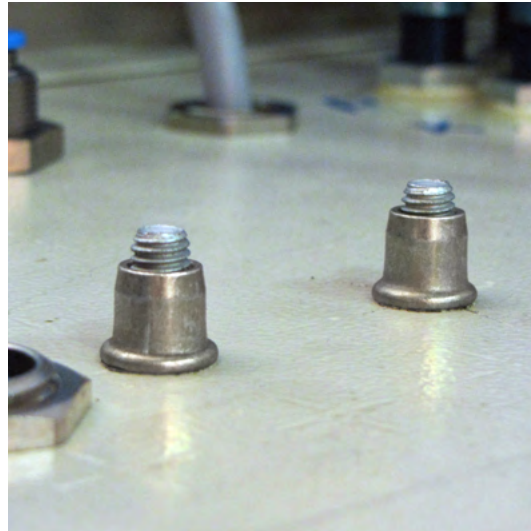

Tubtara[®]
BLIND RIVET NUTS

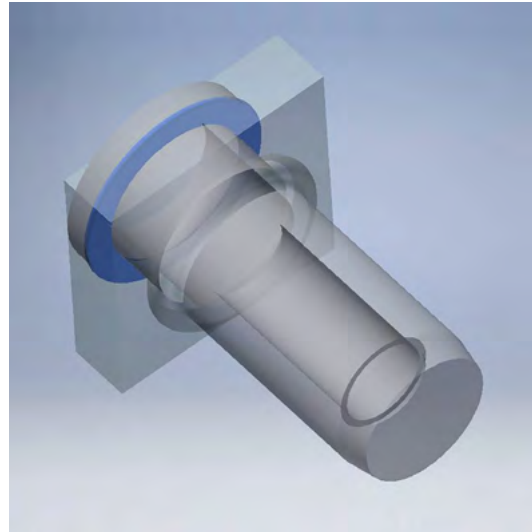

Tubtara[®]
Blind rivet nuts

a fastener by Dejong nv



Significant investments in production:
New heading & degreasing machines
Restructuring tool design shop

2017

2016

Improved ERP - CRM system

New optical control machine

2015

2014

EN 9100 / AS 9100
accreditation for the aerospace
Tubtara® 60 years of innovation!



First to cold form Tubtara's in
stainless A5 & A6

2013

2012

New coatings, development of
the watertight HX **Tubtara®**
in stainless 304 & 316



Important investments in the
production: heading machine for
production of more difficult parts,
degreasing and tapping machines

2008

2005

First to cold form blind rivet nuts in stain-
less steel 316
Zinktop: Dejong's new Cr^{VI}-free surface
treatment

Tubtara® celebrates its
50th birthday!

2004

2002

ISO 9001/2000 accreditation by BVQI
(Bureau Veritas)



Opening of an extension to the
production facility

2000

1989

First to cold form blind rivet nuts in stainless
steel 304

Dejong becomes one of the first
European manufacturers producing cold
formed blind rivet nuts

1966

1954

Launch of the **Tubtara®**
blind rivet nut



Dejong starts to manufacture solid rivets

1938

1901

Foundation of the company by
the family Dejong



General Information	About Dejong	2
	Tubtara blind rivet nuts	4
Stainless Steel 304	Round shank	
	Flat head	6
	Countersunk head	8
	Low profile head	10
	Knurled shank	
	Flat head	12
	Countersunk head with knurl	14
	Low profile head	16
	Semi-hexagonal shank	
	Flat head	18
Low profile head	20	
Stainless Steel 316	Round shank	
	Flat head	22
	Countersunk head	24
	Low profile head	26
	Semi-hexagonal shank	
	Flat head	28
Low profile head	30	
Steel	Round shank	
	Flat head	32
	Countersunk head	34
	Low profile head	36
	Knurled shank	
	Flat head	38
	Countersunk head with knurl	40
	Low profile head	42
	Full-hexagonal shank	
	Flat head	44
	Low profile head	46
	Splined shank	
	Flat head	48
Countersunk head	49	
Aluminium	Round shank	
	Flat head	50
	Countersunk head	52
	Low profile head	54
Watertight solutions	HX and (H)DPX	55
Customised solutions	Application-oriented solutions	63
	Different materials and coatings	66
	Specific anti-rotation head	68
	Special thread requirements	70
Setting Tools	Setting Equipment & Tooling	72
Technical Information	Setting Method	74
	Materials	75
	Coatings	78
	Technical Data	80
	3D drawings	87
	Quality	88
Notes		89

About Dejong

● Metal Matters

Dejong started as a small metal stockist in 1901. Today we are a leading supplier to the industry, renowned for our extensive knowhow in metal. Over 100 employees are dedicated to offering tailor-made solutions and establishing long-term partnerships with their customers and suppliers around the globe.



Our core business :

- stock-keeping wholesaler of non-ferrous metals with service centre
- distributor of exclusive systems for architecture and construction
- industrial supplier of high-quality, value-added mechanical fasteners and fastening systems
- R&D, production, marketing and sale of **Tubtara**® blind rivet nuts.

Considerable investments over the years have helped Dejong strengthen its position as a trendsetter and solution provider. Dejong's name is synonymous with high-quality products, a multi-industry supply, prompt order processing, on-time deliveries and reliable (pre- and aftersales) service. Our ambition is to play a leading role in future product development, always focused on the current and future needs of our customers and end-users.

METAL MATTERS: Dejong does more than just deliver metal products, we forge long-term partnerships through dedicated solutions and customer service.

● Industrial specialist in fastening technology

In its home market, Dejong Fastening Systems (DFS) has become a major player in fastening technology by offering a full range of high-value mechanical fasteners manufactured by different internationally-recognised suppliers, including its own **Tubtara**® blind rivet nut range. The company is dedicated to serving the manufacturing, transportation, aerospace & defence industries.

Thanks to regular supplier product training, in-house expertise and continuous search for new products, Dejong Fastening Systems is able to keep pace with the latest market requirements and trends. In strong partnership with its suppliers, DFS tries to solve its customers' problems and offer advanced products that are perfectly suited to their specific applications.

It is essential that customers think of us as their partner and not just as a product supplier. Our people have the technical knowhow, experience and enthusiasm to help customers find the right product for their application. As experienced specialists, we are dedicated to our customer-partners' success.

In other words: we offer a total quality solution.

Quality

All our employees are committed to offering you excellent service, every day. We are all dedicated to distributing and manufacturing high-quality products, ensuring on-time deliveries and paying close attention to customer satisfaction. And to do so, we continuously invest in quality control and audits. Our EN 9100 accreditation is applicable to the development, production and sale of **Tubtara**® blind rivet nuts and distribution of high-value fastening systems.



● **Tubtara**® - Riveting Matters

Dejond launched its first **Tubtara**® blind rivet nuts back in 1954, which were then machined on a lathe. Only 10 years later, production methods evolved towards more specialised cold forming technology. Today Dejond offers one of the widest ranges of high-quality, cold-formed blind rivet nuts in the world. Each and every rivet nut is manufactured at its EN 9100 certified production facility in Wilrijk (Belgium). **Tubtara**® is a registered trademark of Dejond.

Besides standard and customised blind rivet nuts, the **Tubtara**® team can also custom cold form selected parts according to its customers' drawings for very specific applications.



EN 9100 Certification: Quality guaranteed

The entire **Tubtara**® team is involved in quality assurance and is more than ever committed to meeting the challenges of the future. Living up to our social and ecological responsibilities, we try to create a balance between economic, social and environmental aspects through responsible manufacturing methodologies.



Upon the specific request of our aerospace customers, the **Tubtara**® Division upgraded its ISO 9001 quality management system to the higher EN/AS/JISQ 9100 level in 2014. This certificate helps Dejond to meet its customers' most stringent requirements while strengthening its position in the aerospace industry which imposes strict safety standards and controls to ensure reliable quality. It is comparable to the TS 16949 automotive directive. You will find Dejond in the OASIS (Online Aerospace Supplier Information System) database of the IAQG (International Aerospace Quality Group).



64 years of innovation

Over the last 64 years, the **Tubtara**® division of Dejond has established itself as a pioneer in the production of blind rivet nuts based on a long tradition of innovation. It has been able to use its deep knowledge of materials and cold forming production processes to constantly develop its product portfolio.

The **Tubtara**® team heads into the next 60 years with a clear vision for the future:.

- high and consistent quality performance
- innovation and in-house R&D
- customer partnerships through technical and commercial support
- worry-free deliveries

Tubtara® has the ambition to stay at the forefront of blind rivet nut design and manufacturing. As such, our goal is to continue to play a leading role in future technological developments, which is why we continue to invest in R&D.

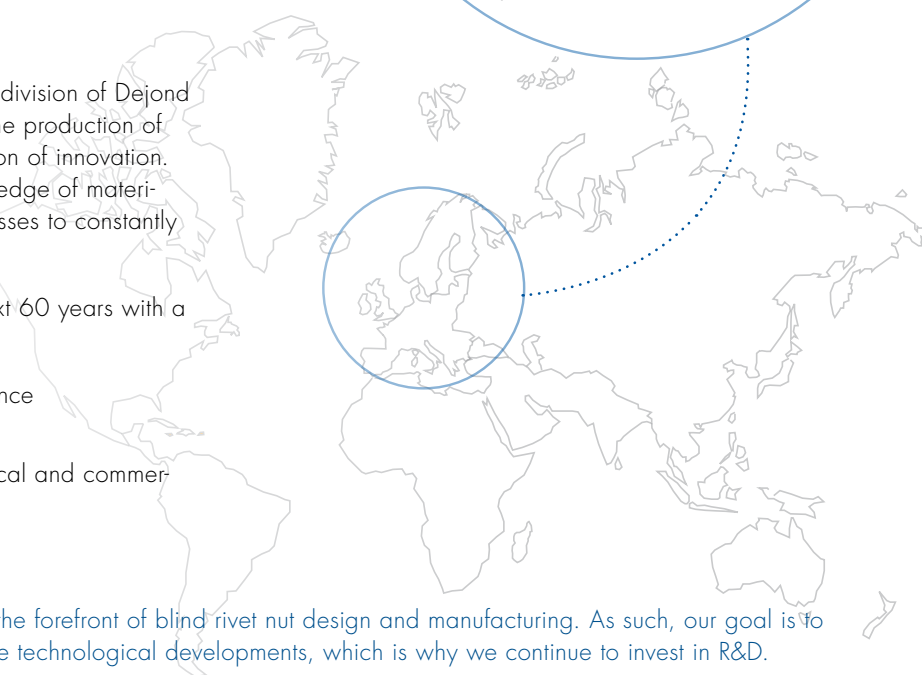

Tubtara® blind rivet nuts

Tubtara® is a mechanical fastener that ensures a strong thread in thin and thick metal plates or profiles, in composites or (engineered) plastics. It is used in applications where there is little or no access from/at the rear. It can clinch separate sheets or profiles together - acting as a rivet - and enables the (dis)assembly of a third component via a bolt or screw.



● Benefits

10 reasons why you should choose **Tubtara®** blind rivet nuts:

1. Simple blind installation: applied from one side of the workpiece
2. Low assembly cost: versus other methods of installing threads in plates or profiles
3. Fast, easy assembly: further reducing the assembly cost
4. Zero-risk installation: no damage to the workpiece surface, enabling installation in pre-coated or pre-painted applications for a clean, undamaged thread
5. No deformation of the workpiece
6. No surface preparation required
7. Ideal for close-to-edge applications
8. Suitable for repeated assembly
9. Retained fastener: cf. machinery directive 2006/42/EC (unloseable after setting)
10. Low installation cost: no expensive tools or equipment required

● Applications

Tubtara® blind rivet nuts are used in all kinds of sheet metal, plastic and composite applications. They eliminate the need for tapping, welding or working with nuts and bolts. As such, they form an ideal solution for enclosed applications that can only be accessed from one side.

Some marketsegments:

- Aerospace
- Automotive
- White Goods
- Electronics
- Metal furniture
- Railways
- Telecom
- Food
- Chemicals
- Lighting
- Marine
- Offshore
- Medical
- Pulp & paper
- etc...

e.g. cabinets, pipes, cable trays, leg levelling, window & door profiles, rails, benches, fences, metal enclosures, heating installations, airconditioning, swimming pools, solar panels etc.

● Installation

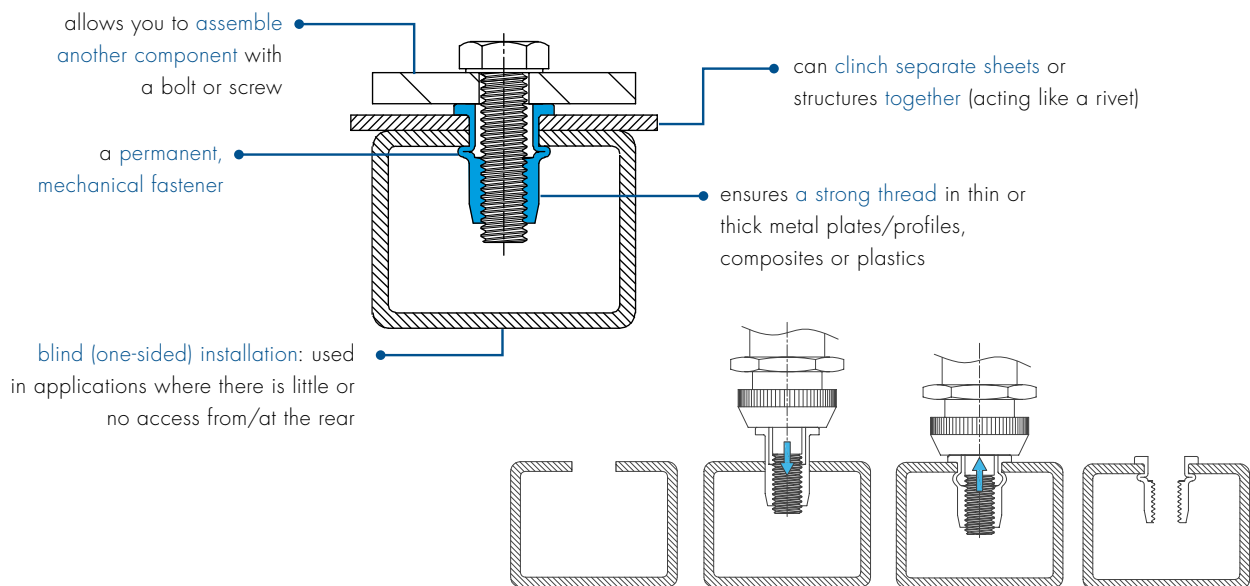

Installation in less than 3 seconds!

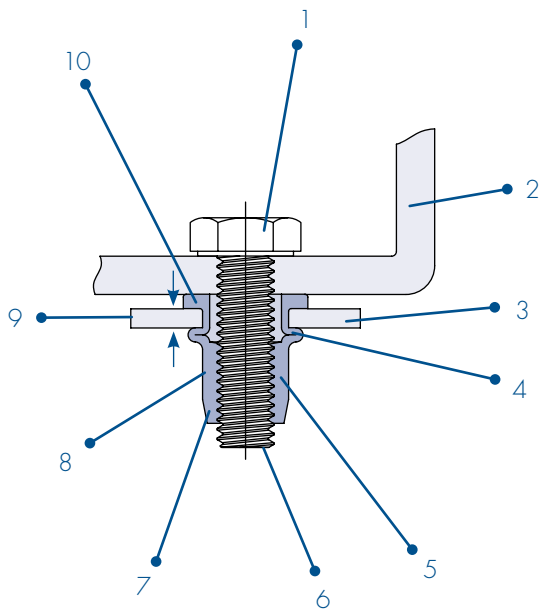

● Terminology

1. Screw or bolt inserted for assembly
2. Assembled part
3. Workpiece: can be 1 sheet/profile or several sheets/profiles which require clinching
4. Bulb or counter head: the chamber (unthreaded section) is deformed during setting
5. Strong, secure internal thread
6. Open or closed end: closed-end version prevents the ingress of dirt and fluids especially in combination with an underhead seal
7. Chamfer: leads the **Tubtara**® into the hole
8. Shank: round, full- or semi-hexagonal, knurled or splined version
9. Grip: the exact material thickness of the workpiece
10. Head: flat, countersunk, low profile, watertight, anti-turn head or customised head type

● Product Description

Steel	M5	RS	UFO	40
Stainless	M10	H	SPX	35
Aluminium	M8	-	UPO	80
Steel	M10	H	SPX	110
Steel	M4	KN	UKO	30
↓	↓	↓	↓	↓
material	thread	shank	head & shank	max grip
		RS: splined H: hexagonal KN: knurled - : round	U / S: Unigrip F: countersunk head P: flat head K: low profile head O: open end X: closed end	40 = 4 mm 35 = 3,5 mm 80 = 8 mm 110 = 11 mm 30 = 3 mm

● How to choose the appropriate **Tubtara**® ?

- What kind of material and surface treatment do you need?
- What is the required thread size?
- Choose the correct griprange for the required material thickness of the application.
- Choose the required head and shank style.
- Do you need an open- or closed-end version?
- Check the technical characteristics of your chosen **Tubtara**®.

We highly recommend testing the product in your specific application in advance.

Samples are available on request.





Stainless Steel 304

Round shank
Flat head
Open end
UPO / SPO

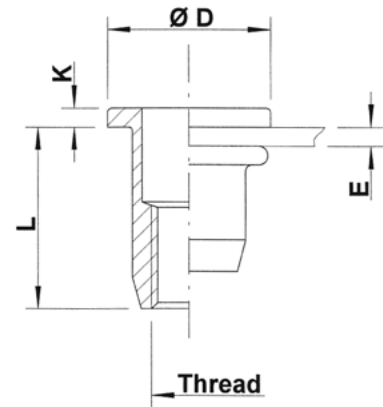
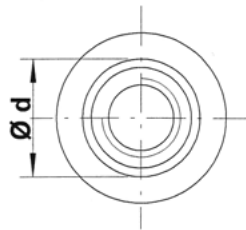

THREAD	TYPE	E = grip	L	b ^{+0,1} = drill dia	d = shank dia	D	K	kg/1000	ORDER CODE	BOX Small	BOX Large
M4	UPO20	0,5-2,0	11,0	6,0	6,0	9,0	1,0	1,5	544 010	(500)	7500
	UPO35	2,0-3,5	12,5						544 020	(500)	5000
M5	UPO30	0,5-3,0	11,5	7,0	7,0	10,0	1,0	1,8	545 040	(500)	4000
	UPO50	3,0-5,0	15,0						545 050	(500)	3000
M6	UPO30	0,5-3,0	14,5	9,0	9,0	12,0	1,5	4,1	546 020	(500)	2000
	UPO50	3,0-5,0	16,5						546 035	(500)	2000
	UPO70	5,0-7,0	18,5						546 050	(500)	2000
M8	UPO30	0,5-3,0	16,0	11,0	11,0	15,0	1,5	6,1	548 010	(500)	1250
	UPO55	3,0-5,5	18,5						548 020	(500)	1250
	UPO80	5,5-8,0	21,5						548 035	(500)	1000
M10	UPO30	0,8-3,0	18,5	12,1	12,0	15,0	1,0	5,9	540 020	(500)	1000
	UPO50	3,0-5,0	20,5						540 030	(500)	1000
M10	SPO35	0,8-3,5	21,5	13,0	13,0	17,0	1,5	10,2	540 600	(100)	750
	SPO60	3,5-6,0	24,0						540 605	(100)	750
M12	UPO40	1,0-4,0	25,0	16,0	16,0	23,0	2,0	19,1	542 020	(100)	400
	UPO70	3,0-7,0	28,0						542 050	(100)	300

Small box: only for DFS customers, not export - (xxx) handling cost can be charged

All dimensions in mm - Technical data subject to modification
Tolerances and characteristics see chapter "Technical Data"





Stainless Steel 304

Round shank
Flat head
Closed end

UPX / SPX

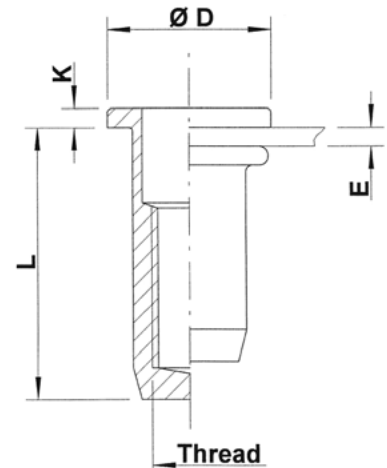
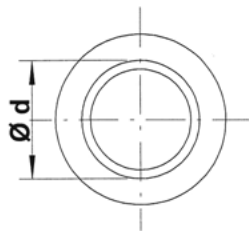

THREAD	TYPE	E = grip	L	b ^{+0,1} = drill dia	d = shank dia	D	K	kg/1000	ORDER CODE	BOX Small	BOX Large
M4	UPX20	0,5-2,0	15,0	6,0	6,0	9,0	1,0	2,2	544 110	(500)	5000
	UPX35	2,0-3,5	16,5					2,3	544 115*	-	-
M5	UPX30	0,5-3,0	17,5	7,0	7,0	10,0	1,0	3,0	545 180	(500)	2500
	UPX50	3,0-5,0	19,5					3,2	545 185	(500)	2500
M6	UPX30	0,5-3,0	21,5	9,0	9,0	12,0	1,5	6,6	546 100	(500)	1500
	UPX50	3,0-5,0	23,5					6,9	546 105	(500)	1500
M8	UPX30	0,5-3,0	23,5	11,0	11,0	15,0	1,5	9,9	548 065	(500)	1000
	UPX55	3,0-5,5	26,0					10,2	548 066	(500)	750
M10	SPX35	0,8-3,5	28,5	13,0	13,0	17,0	1,5	16,0	540 630	(100)	500
	SPX60	3,5-6,0	31,0					17,0	540 631	(100)	500
M12	UPX70	3,0-7,0	38,5	16,0	16,0	23,0	2,0	27,0	542 200*	-	-

Small box: only for DFS customers, not export - (xxx) handling cost can be charged

* **Non-stock item:** minimum order quantity required after depletion of stock

All dimensions in mm - Technical data subject to modification
Tolerances and characteristics see chapter "Technical Data"





Stainless Steel 304

Round shank
Countersunk head
Open end

UFO / SFO

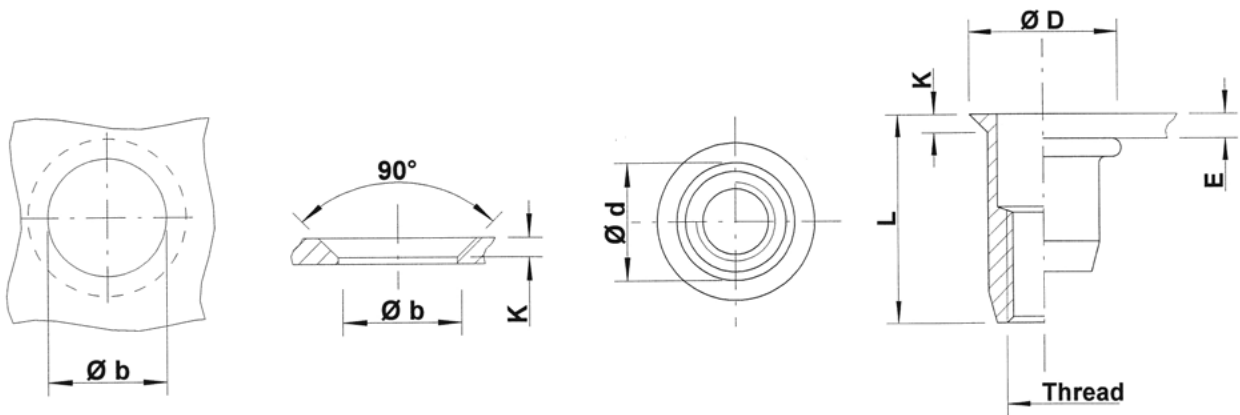

THREAD	TYPE	E = grip	L	b ^{+0,1} = drill dia	d = shank dia	D	K	kg/1000	ORDER CODE	BOX Small	BOX Large
M4	UFO30	1,2-3,0	12,0	6,0	6,0	8,0	1,0	1,3	544 120	(500)	7500
M5	UFO35	1,2-3,5	12,0	7,0	7,0	9,0	1,0	1,6	545 200	(500)	5000
M6	UFO45	1,7-4,5	17,0	9,0	9,0	12,0	1,5	4,2	546 125	(500)	2000
	UFO65	4,5-6,5	19,0					4,5	546 130*	-	-
M8	UFO45	1,7-4,5	17,5	11,0	11,0	14,0	1,5	5,5	548 070	(500)	1250
	UFO65	4,5-6,5	19,5					5,8	548 075	(500)	1250
M10	UFO45	1,7-4,5	20,0	12,1	12,0	15,0	1,5	5,9	540 090	(100)	1000
M10	SFO45	1,7-4,5	22,5	13,0	13,0	16,0	1,5	9,5	540 610	(100)	750
M12	UFO55	2,0-5,5	27,0	16,0	16,0	19,0	1,8	18,0	542 260*	-	-

Small box: only for DFS customers, not export - (xxx) handling cost can be charged

* **Non-stock item:** minimum order quantity required after depletion of stock

All dimensions in mm - Technical data subject to modification
Tolerances and characteristics see chapter 'Technical Information'



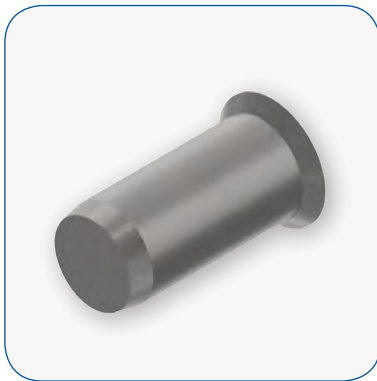

Stainless Steel 304

Round shank
Countersunk head
Closed end

UFX / SFX

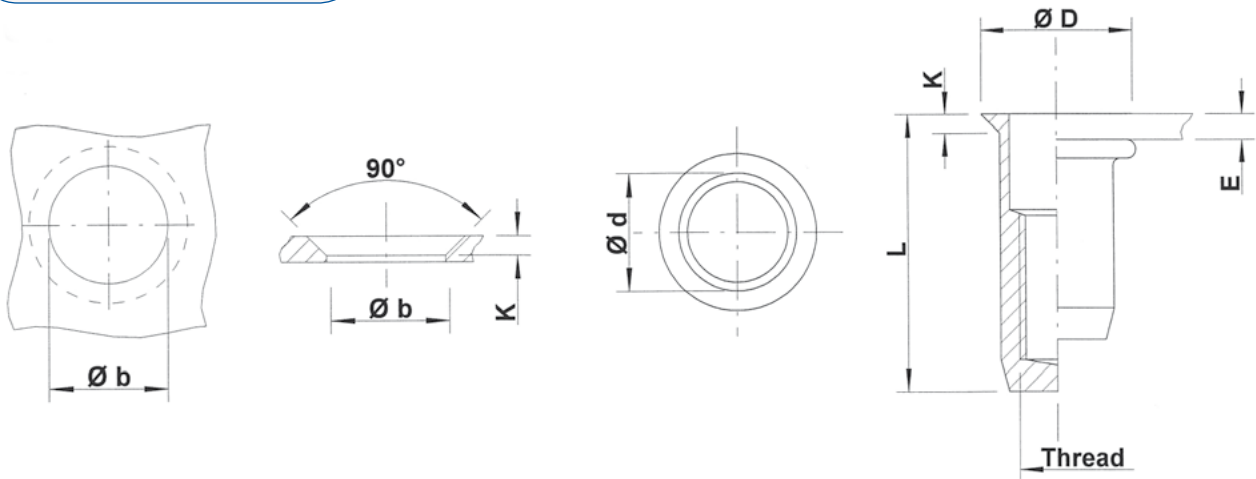

THREAD	TYPE	E = grip	L	b ^{+0,1} = drill dia	d = shank dia	D	K	kg/1000	ORDER CODE	BOX Small	BOX Large
M4	UFX30	1,2-3,0	16,0	6,0	6,0	8,0	1,0	2,0	544 210	(500)	5000
M5	UFX35	1,2-3,5	18,0	7,0	7,0	9,0	1,0	2,8	545 340	(500)	2500
M6	UFX45	1,7-4,5	24,0	9,0	9,0	12,0	1,5	6,7	546 260	(500)	1500
	UFX65	4,5-6,5	26,0					7,0	546 270	-	-
M8	UFX45	1,7-4,5	25,0	11,0	11,0	14,0	1,5	9,3	548 150	(500)	1000
	UFX65	4,5-6,5	27,0					9,6	548 155	(500)	750
M10	SFX45	1,7-4,5	30,5	13,0	13,0	16,0	1,5	14,3	540 615	(100)	500
M12	UFX55	2,0-5,5	37,0	16,0	16,0	19,0	1,8	24,8	542 360*	-	-

Small box: only for DFS customers, not export - (xxx) handling cost can be charged

* **Non-stock item:** minimum order quantity required after depletion of stock

All dimensions in mm - Technical data subject to modification

Tolerances and characteristics see chapter 'Technical Information'





Stainless Steel 304

Round shank
Low profile head
Open end

UKO / SKO

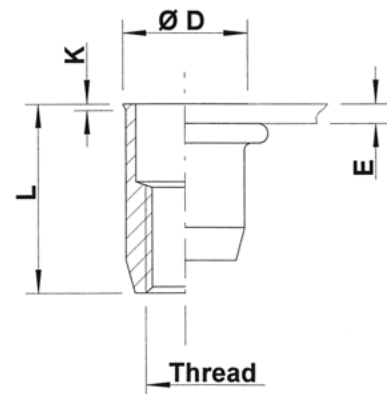
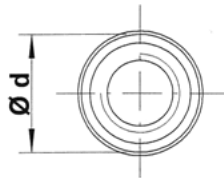
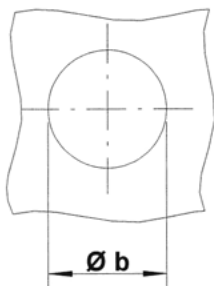

THREAD	TYPE	E = grip	L	b ^{+0,1} = drill dia	d = shank dia	D	K	kg/1000	ORDER CODE	BOX Small	BOX Large
M4	UKO20	0,5-2,0	11,0	6,0	6,0	6,5	0,5	1,1	544 220	1000	10000
M5	UKO30	0,5-3,0	12,0	7,0	7,0	7,5	0,5	1,5	545 400	1000	5000
	UKO50	3,0-5,0	15,0							(500)	5000
M6	UKO30	0,5-3,0	14,5	9,0	9,0	9,5	0,5	3,4	546 400	1000	3000
	UKO50	3,0-5,0	16,5							-	-
M8	UKO30	0,5-3,0	16,0	11,0	11,0	11,5	0,5	5,0	548 160	1000	2000
	UKO55	3,0-5,5	18,5							(500)	1500
M10	SKO35	0,8-3,5	21,0	13,0	13,0	13,5	0,5	8,5	540 620	(100)	1000
	SKO60	3,5-6,0	23,5							-	-
M12	UKO40	1,0-4,0	26,0	16,0	16,0	16,8	0,7	17,0	542 400*	-	-

Small box: only for DFS customers, not export - (xxx) handling cost can be charged

* **Non-stock item:** minimum order quantity required after depletion of stock

All dimensions in mm - Technical data subject to modification

Tolerances and characteristics see chapter 'Technical Information'





Stainless Steel 304

Round shank
Low profile head
Closed end

UKX

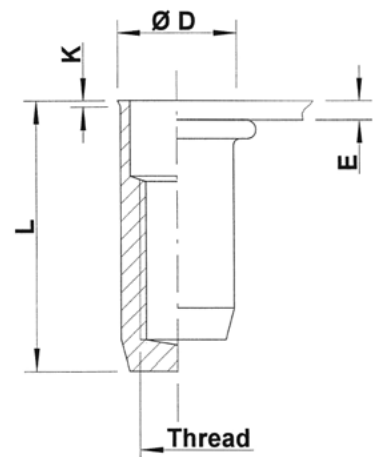
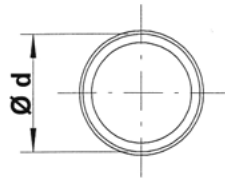

THREAD	TYPE	E = grip	L	b ^{+0,1} = drill dia	d = shank dia	D	K	kg/1000	ORDER CODE	BOX Small	BOX Large
M4	UKX20	0,5-2,0	15,5	6,0	6,0	6,5	0,5	1,9	544 250	(500)	5000
M5	UKX30	0,5-3,0	18,0	7,0	7,0	7,5	0,5	2,7	545 450	(500)	4000
M6	UKX30	0,5-3,0	21,5	9,0	9,0	9,5	0,5	5,8	546 450	(500)	2000
M8	UKX30	0,5-3,0	24,0	11,0	11,0	11,5	0,5	8,8	548 190	(500)	1250

Small box: only for DFS customers, not export - (xxx) handling cost can be charged

M10: programme in progress

All dimensions in mm - Technical data subject to modification

Tolerances and characteristics see chapter 'Technical Information'





Stainless Steel 304

Knurled shank
Flat head
Open end

UPO KN / SPO KN

improved
nominal knurl

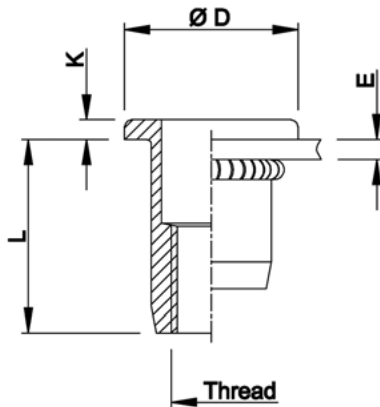
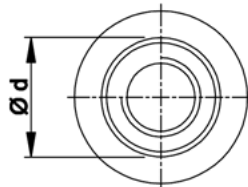
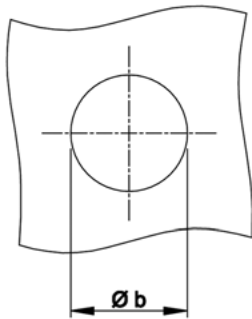

THREAD	TYPE	E = grip	L	b ^{+0,1} = drill dia	d = shank dia	D	K	kg/1000	ORDER CODE	BOX Small	BOX Large
M4	UPO20 KN	0,5-2,0	11,0	6,0	6,0	9,0	1,0	1,5	544 0107*	-	7500
M5	UPO30 KN	0,5-3,0	11,5	7,0	7,0	10,0	1,0	1,8	545 0407*	-	4000
	UPO50 KN	3,0-5,0	15,0						545 0507*	-	3000
M6	UPO30 KN	0,5-3,0	14,5	9,0	9,0	12,0	1,5	4,1	546 0207	(500)	2000
	UPO50 KN	3,0-5,0	16,5						546 0357*	-	2000
M8	UPO30 KN	0,5-3,0	16,0	11,0	11,0	16,0	1,5	6,1	548 0107*	-	1250
	UPO55 KN	3,0-5,5	18,5						548 0207*	-	1250
M10	SPO35 KN	0,8-3,5	21,5	13,0	13,0	17,0	1,5	10,2	540 6007*	-	750

Small box: only for DFS customers, not export - (xxx) handling cost can be charged

* **Non-stock item:** minimum order quantity required after depletion of stock

KN programme in progress

All dimensions in mm - Technical data subject to modification

Tolerances and characteristics see chapter 'Technical Information'





Stainless Steel 304

Knurled shank
Flat head
Closed end

UPX KN

improved
nominal knurl

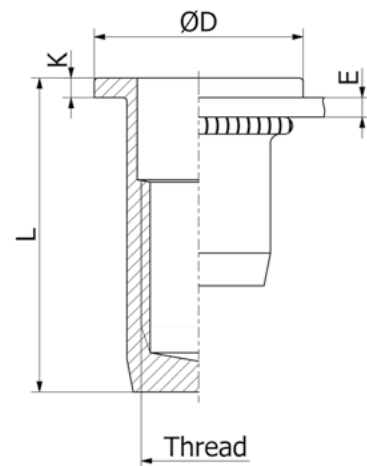
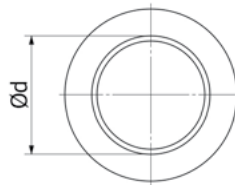
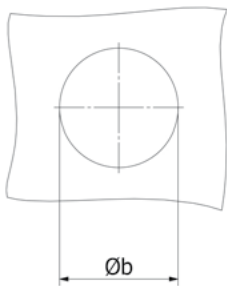

THREAD	TYPE	E = grip	L	b ^{+0,1} = drill dia	d = shank dia	D	K	kg/1000	ORDER CODE	BOX Small	BOX Large
M5	UPX30 KN	0,5-3,0	17,5	7,0	7,0	10,0	1,0	3,0	545 1807*	-	2500
M6	UPX30 KN	0,5-3,0	21,5	9,0	9,0	12,0	1,5	6,6	546 1007*	-	1500
M8	UPX30 KN	0,5-3,0	23,5	11,0	11,0	16,0	1,5	9,9	548 0657*	-	1000

Small box: only for DFS customers, not export - (xxx) handling cost can be charged

* **Non-stock item:** minimum order quantity required after depletion of stock

KN programme in progress

All dimensions in mm - Technical data subject to modification

Tolerances and characteristics see chapter 'Technical Information'





Stainless Steel 304

Knurled shank
Countersunk head with knurl
Open end

UFO KN / SFO KN

improved nominal knurl

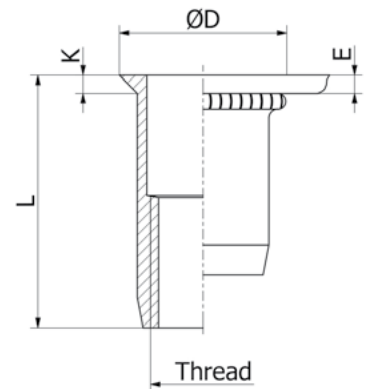
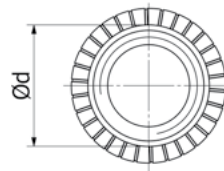
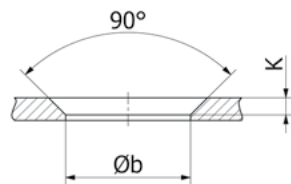
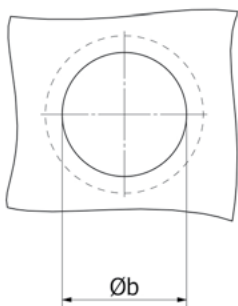

THREAD	TYPE	E = grip	L	b ^{+0,1} = drill dia	d = shank dia	D	K	kg/1000	ORDER CODE	BOX Small	BOX Large
M4	UFO30 KN	1,2-3,0	12,0	6,0	6,0	8,0	1,0	1,3	544 1207*	-	7500
M5	UFO35 KN	1,2-3,5	12,0	7,0	7,0	9,0	1,0	1,6	545 2007*	-	5000
M6	UFO45 KN	1,7-4,5	17,0	9,0	9,0	12,0	1,5	4,2	546 1257*	-	2000
M8	UFO45 KN	1,7-4,5	17,5	11,0	11,0	14,0	1,5	5,5	548 0707*	-	1250
M10	SFO45 KN	1,7-4,5	22,5	13,0	13,0	15,0	1,5	5,9	540 6107*	-	750

Small box: only for DFS customers, not export - (xxx) handling cost can be charged

* **Non-stock item:** minimum order quantity required after depletion of stock

KN programme in progress

All dimensions in mm - Technical data subject to modification
Tolerances and characteristics see chapter 'Technical Information'





Stainless Steel 304

Knurled shank
Countersunk head with knurl
Closed end

UFX KN / SFX KN

improved
nominal knurl

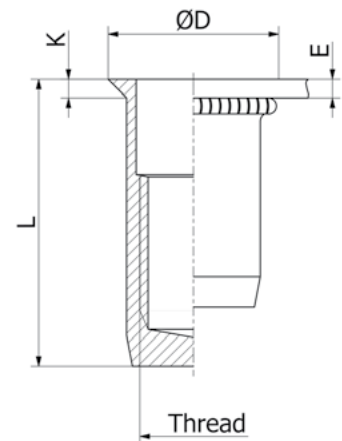
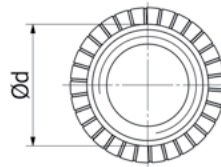
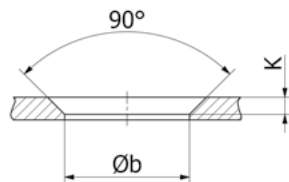
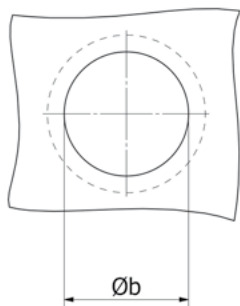

THREAD	TYPE	E = grip	L	b ^{+0,1} = drill dia	d = shank dia	D	K	kg/1000	ORDER CODE	BOX Small	BOX Large
M4	UFX30 KN	1,2-3,0	16,0	6,0	6,0	8,0	1,0	2,0	544 2107*	-	-
M5	UFX35 KN	1,2-3,5	18,0	7,0	7,0	9,0	1,0	2,9	545 3407*	-	-
M6	UFX45 KN	1,7-4,5	24,0	9,0	9,0	12,0	1,5	6,8	546 2607*	-	-
M8	UFX45 KN	1,7-4,5	25,0	11,0	11,0	14,0	1,5	9,3	5481 507*	-	-
M10	SFX45 KN	1,7-4,5	30,5	13,0	13,0	15,0	1,5	13,3	540 6157*	-	-

Small box: only for DFS customers, not export - (xxx) handling cost can be charged

* **Non-stock item:** minimum order quantity required after depletion of stock

KN programme in progress

All dimensions in mm - Technical data subject to modification

Tolerances and characteristics see chapter 'Technical Information'





Stainless Steel 304

Knurled shank
Low profile head
Open end

UKO KN / SKO KN

improved nominal knurl

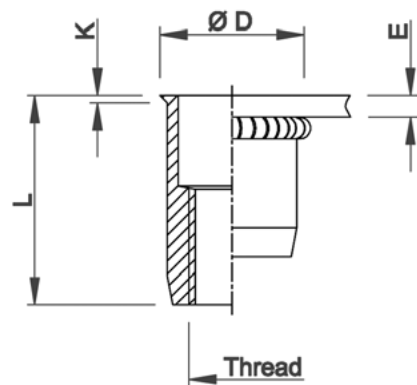
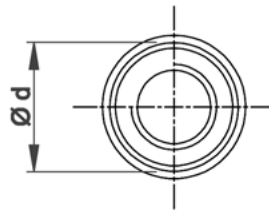
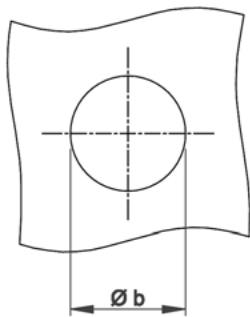

THREAD	TYPE	E = grip	L	b ^{+0,1} = drill dia	d = shank dia	D	K	kg/1000	ORDER CODE	BOX Small	BOX Large
M4	UKO20 KN	0,5-2,0	11,0	6,0	6,0	6,5	0,5	1,1	544 2207	(500)	10000
M5	UKO30 KN	0,5-3,0	12,0	7,0	7,0	7,5	0,5	1,5	545 4007	(500)	5000
	UKO50 KN	3,0-5,0	15,0								
M6	UKO30 KN	0,5-3,0	14,5	9,0	9,0	9,5	0,5	3,4	546 4007	(500)	3000
	UKO50 KN	3,0-5,0	16,5								
M8	UKO30 KN	0,5-3,0	16,0	11,0	11,0	11,5	0,5	5,0	548 1607	(500)	2000
	UKO55 KN	3,0-5,5	18,5								
M10	SKO35 KN	0,8-3,5	21,0	13,0	13,0	13,5	0,5	8,5	540 6207*	-	1000

Small box: only for DFS customers, not export - (xxx) handling cost can be charged

* **Non-stock item:** minimum order quantity required after depletion of stock

KN programme in progress

All dimensions in mm - Technical data subject to modification

Tolerances and characteristics see chapter 'Technical Information'



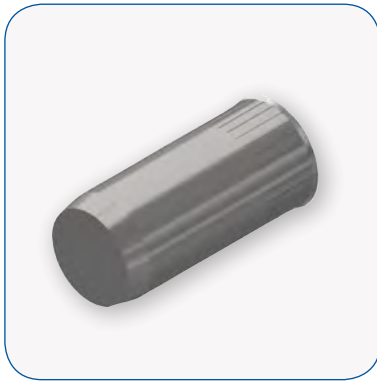

Stainless Steel 304

Knurled shank
Low profile head
Closed end

UKX KN

improved
nominal knurl

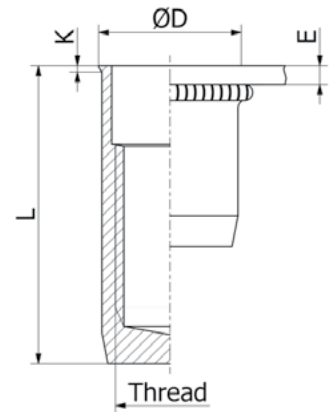
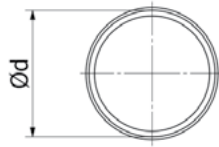
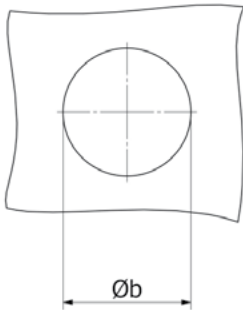

THREAD	TYPE	E = grip	L	b ^{+0,1} = drill dia	d = shank dia	D	K	kg/1000	ORDER CODE	BOX Small	BOX Large
M5	UKX30 KN	0,5-3,0	18,0	7,0	7,0	7,5	0,5	2,7	545 4507*	-	4000
M6	UKX30 KN	0,5-3,0	21,5	9,0	9,0	9,5	0,5	5,8	546 4507*	-	2000
M8	UKX30 KN	0,5-3,0	24,0	11,0	11,0	11,0	0,5	8,8	548 1907*	-	1250

Small box: only for DFS customers, not export - (xxx) handling cost can be charged

* **Non-stock item:** minimum order quantity required after depletion of stock

KN programme in progress

All dimensions in mm - Technical data subject to modification

Tolerances and characteristics see chapter 'Technical Information'





Stainless Steel 304

Semi-hexagonal shank
Flat head
Open end

HUPO / HSPO

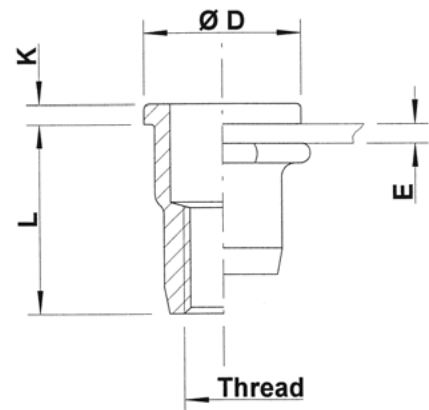
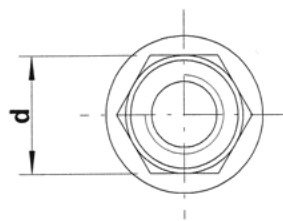
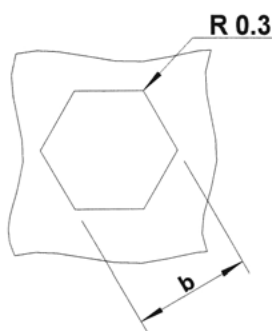

THREAD	TYPE	E = grip	L	b ^{+0,1} = hex hole	d = hex shank	D	K	kg/1000	ORDER CODE	BOX Small	BOX Large
M4	HUPO20	0,5-2,0	11,0	6,0	6,0	9,0	1,0	1,5	544 500	(500)	7500
	HUPO30	1,0-3,0	12,0	6,0	6,0	9,0	1,0	1,6	544 510*	-	-
M5	HUPO30	0,5-3,0	11,5	7,0	7,0	10,0	1,0	1,8	545 500	(500)	4000
	HUPO50	3,0-5,0	13,5	7,0	7,0	10,0	1,0	2,0	545 505	-	-
M6	HUPO30	0,5-3,0	14,5	9,0	9,0	12,0	1,5	4,0	546 460	(500)	2500
	HUPO50	3,0-5,0	16,5	9,0	9,0	12,0	1,5	4,3	546 485	-	2000
M8	HUPO30	0,5-3,0	16,0	11,0	11,0	15,0	1,5	6,1	548 250	(500)	1250
	HUPO55	3,0-5,5	18,5	11,0	11,0	15,0	1,5	6,4	548 270	(500)	1000
M10	HSPO35	0,8-3,5	21,5	13,0	13,0	17,0	1,5	11,0	540 632	(100)	750
	HSPO60	3,5-6,0	24,0	13,0	13,0	17,0	1,5	12,0	540 633	(100)	700
M12	HUPO70	3,0-7,0	28,0	16,0	16,0	23,0	2,0	22,0	542 640	(100)	300

Small box: only for DFS customers, not export - (xxx) handling cost can be charged

* **Non-stock item:** minimum order quantity required after depletion of stock

All dimensions in mm - Technical data subject to modification

Tolerances and characteristics see chapter 'Technical Information'





Stainless Steel 304

Semi-hexagonal shank
Flat head
Closed end

HUPX / HSPX

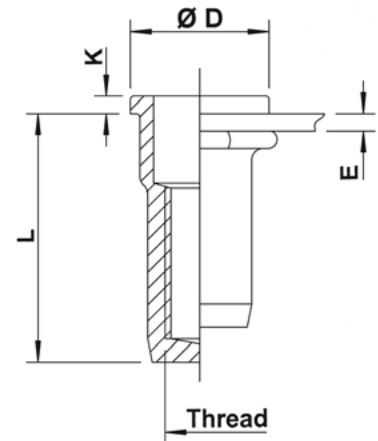
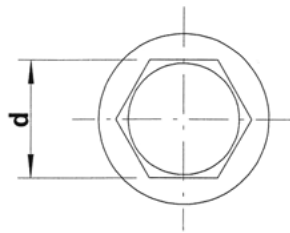
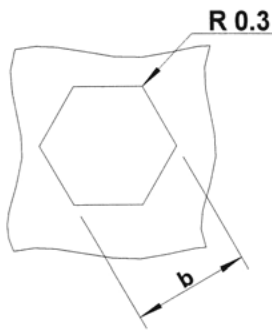

THREAD	TYPE	E = grip	L	b ^{+0,1} = hex hole	d = hex shank	D	K	kg/1000	ORDER CODE	BOX Small	BOX Large
M4	HUPX20	0,5-2,0	15,0	6,0	6,0	9,0	1,0	2,2	544 520	(500)	5000
	HUPX30	1,0-3,0	16,0					2,3	544 530*	-	-
M5	HUPX30	0,5-3,0	17,5	7,0	7,0	10,0	1,0	3,0	545 520	(500)	2500
	HUPX50	3,0-5,0	19,5					3,2	545 525	(500)	2000
M6	HUPX30	0,5-3,0	21,5	9,0	9,0	12,0	1,5	6,6	546 470	(500)	1500
	HUPX50	3,0-5,0	23,5					6,9	546 475	(500)	1250
M8	HUPX30	0,5-3,0	23,5	11,0	11,0	15,0	1,5	9,6	548 260	(500)	750
	HUPX55	3,0-5,5	26,0					10,0	548 280	(500)	1000
M10	HSPX35	0,8-3,5	28,5	13,0	13,0	17,0	1,5	16,0	540 635	(100)	500
	HSPX60	3,5-6,0	31,0					17,0	540 636	(100)	500
M12	HUPX70	3,0-7,0	38,5	16,0	16,0	23,0	2,0	28,0	542 680	-	-

Small box: only for DFS customers, not export - (xxx) handling cost can be charged

* **Non-stock item:** minimum order quantity required after depletion of stock

All dimensions in mm - Technical data subject to modification

Tolerances and characteristics see chapter 'Technical Information'





Stainless Steel 304

Semi-hexagonal shank
Low profile head
Open end

HUKO / HSKO

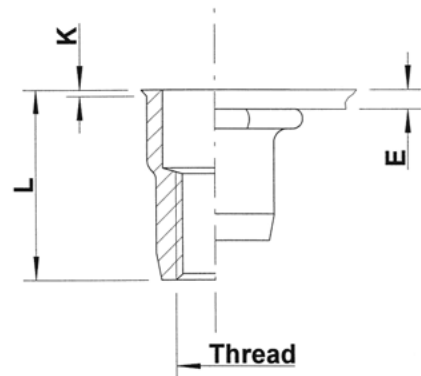
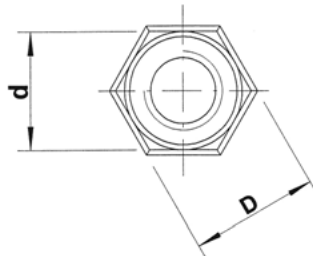
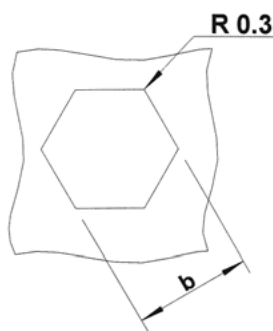

THREAD	TYPE	E = grip	L	b ^{+0,1} = hex hole	d = hex shank	D = hex head	K	kg/1000	ORDER CODE	BOX Small	BOX Large
M4	HUKO20	0,5-2,0	11,0	6,0	6,0	6,5	0,5	1,2	544 600	1000	7500
	HUKO30	2,0-3,0	11,0						544 909*	-	7500
M5	HUKO30	0,5-3,0	12,0	7,0	7,0	7,5	0,5	1,5	545 600	1000	5000
	HUKO50	3,0-5,0	14,0						545 605	(500)	5000
M6	HUKO30	0,5-3,0	14,5	9,0	9,0	9,7	0,5	3,3	546 500	1000	3000
	HUKO50	3,0-5,0	16,5						546 525	(500)	2500
	HUKO70	5,0-7,0	18,5						546 580*	-	2000
M8	HUKO30	0,5-3,0	16,0	11,0	11,0	11,8	0,5	4,9	548 300	500	2000
	HUKO55	3,0-5,5	18,5						548 305	(500)	1500
	HUKO80	5,5-8,0	21,0						548 310*	-	-
M10	HSKO35	0,8-3,5	21,0	13,0	13,0	13,8	0,7	8,4	540 640	(100)	1000
	HSKO60	3,5-6,0	23,5						540 645*	-	750
M12	HUKO70	4,0-7,0	28,5	16,0	16,0	17,5	1,1	22,0	542 840	-	-

Small box: only for DFS customers, not export - (xxx) handling cost can be charged

* **Non-stock item:** minimum order quantity required after depletion of stock

All dimensions in mm - Technical data subject to modification
Tolerances and characteristics see chapter 'Technical Information'





Stainless Steel 304

Semi-hexagonal shank
Low profile head
Closed end

HUKX / HSKX

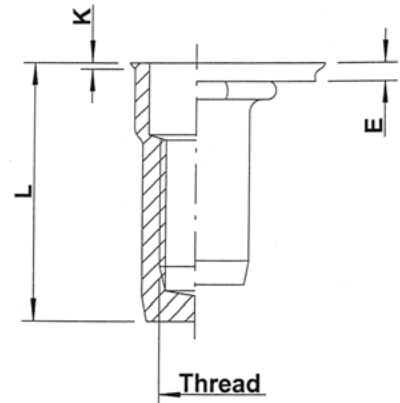
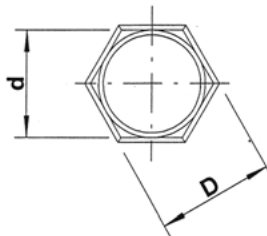
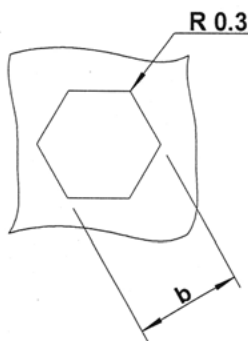

THREAD	TYPE	E = grip	L	b ^{+0,1} = hex hole	d = hex shank	D = hex head	K	kg/1000	ORDER CODE	BOX Small	BOX Large
M4	HUKX20	0,5-2,0	15,5	6,0	6,0	6,5	0,5	1,8	544 620	(500)	5000
	HUKX30	2,0-3,0	16,5					1,9	544 640*	-	-
M5	HUKX30	0,5-3,0	18,0	7,0	7,0	7,5	0,5	2,7	545 620	(500)	4000
	HUKX50	3,0-5,0	20,5					2,9	545 640	(500)	3000
M6	HUKX30	0,5-3,0	21,5	9,0	9,0	9,7	0,5	5,7	546 540	(500)	2000
	HUKX50	3,0-5,0	23,5					6,1	546 565	(500)	2000
	HUKX70	5,0-7,0	25,5					6,5	546 590*	-	-
M8	HUKX30	0,5-3,0	24,0	11,0	11,0	11,8	0,5	8,7	548 320	(500)	1000
	HUKX55	3,0-5,5	26,5					9,1	548 340	(500)	1000
	HUKX80	5,5-8,0	29,0					9,5	548 350*	-	-
M10	HSKX35	0,8-3,5	29,5	13,0	13,0	13,8	0,7	14,2	540 660	-	-
	HSKX60	3,5-6,0	32,0					15,2	540 670*	-	-
M12	HUKX70	4,0-7,0	39,0	16,0	16,0	17,5	1,1	28,7	542 880	(100)	300

Small box: only for DFS customers, not export - (xxx) handling cost can be charged

* **Non-stock item:** minimum order quantity required after depletion of stock

All dimensions in mm - Technical data subject to modification
Tolerances and characteristics see chapter 'Technical Information'





Stainless Steel 316

(contains > 2% Molybden)

Round shank
Flat head
Open end

UPO / SPO

extra high
corrosion resistance

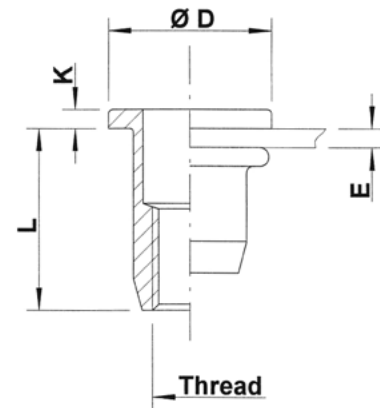
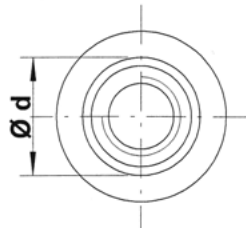

THREAD	TYPE	E = grip	L	b ^{+0,1} = drill dia	d = shank dia	D	K	kg/1000	ORDER CODE	BOX Small	BOX Large
M4	UPO20	0,5-2,0	11,0	6,0	6,0	9,0	1,0	1,5	554 010	(500)	3000
	UPO35	2,0-3,5	12,5						554 020*	-	-
M5	UPO30	0,5-3,0	11,5	7,0	7,0	10,0	1,0	1,8	555 040	(500)	2000
	UPO50	3,0-5,0	15,0						555 050	-	-
M6	UPO30	0,5-3,0	14,5	9,0	9,0	12,0	1,5	4,1	556 020	(500)	1000
	UPO50	3,0-5,0	16,5						556 035	(500)	1000
	UPO70	5,0-7,0	18,5						556 050	(500)	750
M8	UPO30	0,5-3,0	16,0	11,0	11,0	15,0	1,5	6,1	558 010	-	500
	UPO55	3,0-5,5	18,5						558 020	-	500
	UPO80	5,5-8,0	21,5						558 035	-	500
M10	SPO35	0,8-3,5	21,5	13,0	13,0	17,0	1,5	10,2	550 600	(100)	250
	SPO60	3,5-6,0	24,0						550 605	(100)	350

Small box: only for DFS customers, not export - (xxx) handling cost can be charged

* **Non-stock item:** minimum order quantity required after depletion of stock

All dimensions in mm - Technical data subject to modification

Tolerances and characteristics see chapter 'Technical Information'





Stainless Steel 316

(contains > 2% Molybden)

Round shank
Flat head
Closed end

UPX / SPX

extra high
corrosion resistance

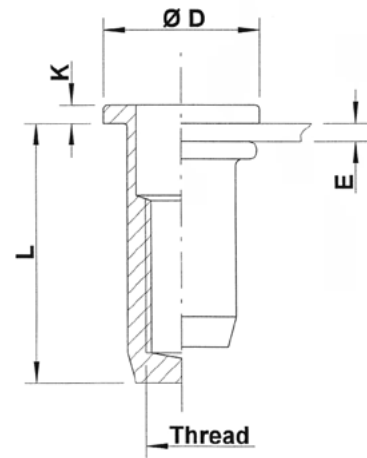
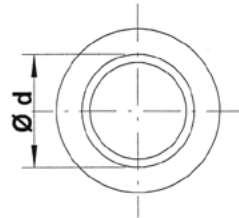
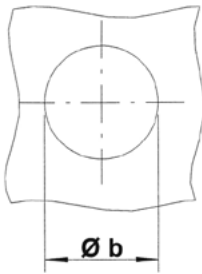

THREAD	TYPE	E = grip	L	b ^{+0,1} = drill dia	d = shank dia	D	K	kg/1000	ORDER CODE	BOX Small	BOX Large
M4	UPX20	0,5-2,0	15,0	6,0	6,0	9,0	1,0	2,2	554 110	(500)	1500
	UPX35	2,0-3,5	16,5					2,3	554 115*	-	-
M5	UPX30	0,5-3,0	17,5	7,0	7,0	10,0	1,0	3,0	555 180	(500)	1500
	UPX50	3,0-5,0	19,5					3,2	555 185	-	1500
M6	UPX30	0,5-3,0	21,5	9,0	9,0	12,0	1,5	6,6	556 100	(500)	750
	UPX50	3,0-5,0	23,5					6,9	556 105	(500)	750
M8	UPX30	0,5-3,0	23,5	11,0	11,0	15,0	1,5	9,9	558 065	(500)	1000
	UPX55	3,0-5,5	26,0					10,2	558 066	-	400
M10	SPX35	0,8-3,5	28,5	13,0	13,0	17,0	1,5	16,0	550 630*	-	-
	SPX60	3,5-6,0	31,0					17,0	550 631*	-	-

Small box: only for DFS customers, not export - (xxx) handling cost can be charged

* **Non-stock item:** minimum order quantity required after depletion of stock

All dimensions in mm - Technical data subject to modification

Tolerances and characteristics see chapter 'Technical Information'





Stainless Steel 316

(contains > 2% Molybden)

Round shank
Countersunk head
Open end

UFO / SFO

extra high
corrosion resistance

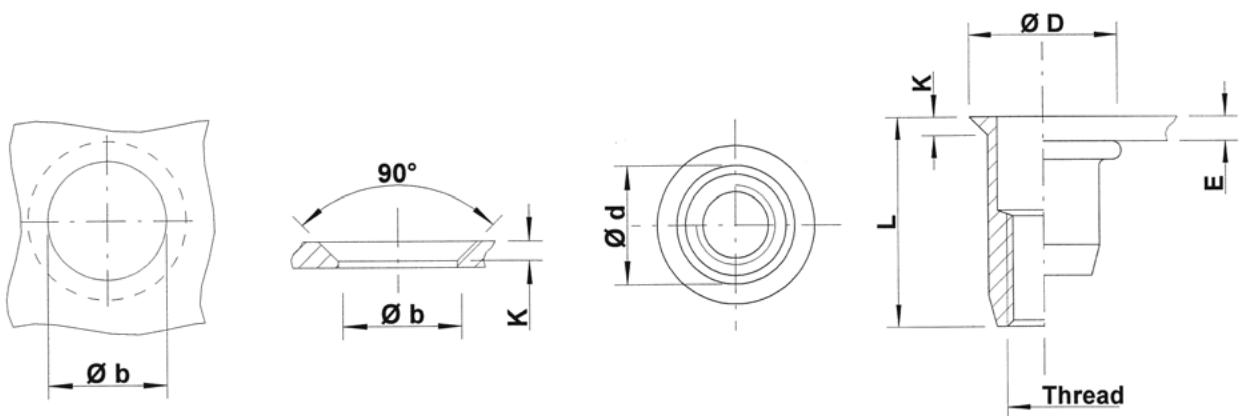

THREAD	TYPE	E = grip	L	b ^{+0,1} = drill dia	d = shank dia	D	K	kg/1000	ORDER CODE	BOX Small	BOX Large
M4	UFO30	1,2-3,0	12,0	6,0	6,0	8,0	1,0	1,3	554 120*	-	-
M5	UFO35	1,2-3,5	12,0	7,0	7,0	9,0	1,0	1,6	555 200	(500)	2000
M6	UFO45	1,7-4,5	17,0	9,0	9,0	12,0	1,5	4,2	556 125	(500)	1000
M8	UFO45	1,7-4,5	17,5	11,0	11,0	14,0	1,5	5,5	558 070	(500)	750
M10	SFO45	1,7-4,5	22,5	13,0	13,0	16,0	1,5	9,5	550 610*	-	350

Small box: only for DFS customers, not export - (xxx) handling cost can be charged

* Non-stock item: minimum order quantity required after depletion of stock

All dimensions in mm - Technical data subject to modification
Tolerances and characteristics see chapter 'Technical Information'





Stainless Steel 316

(contains > 2% Molybden)

Round shank
Countersunk head
Closed end

UFX / SFX

extra high
corrosion resistance

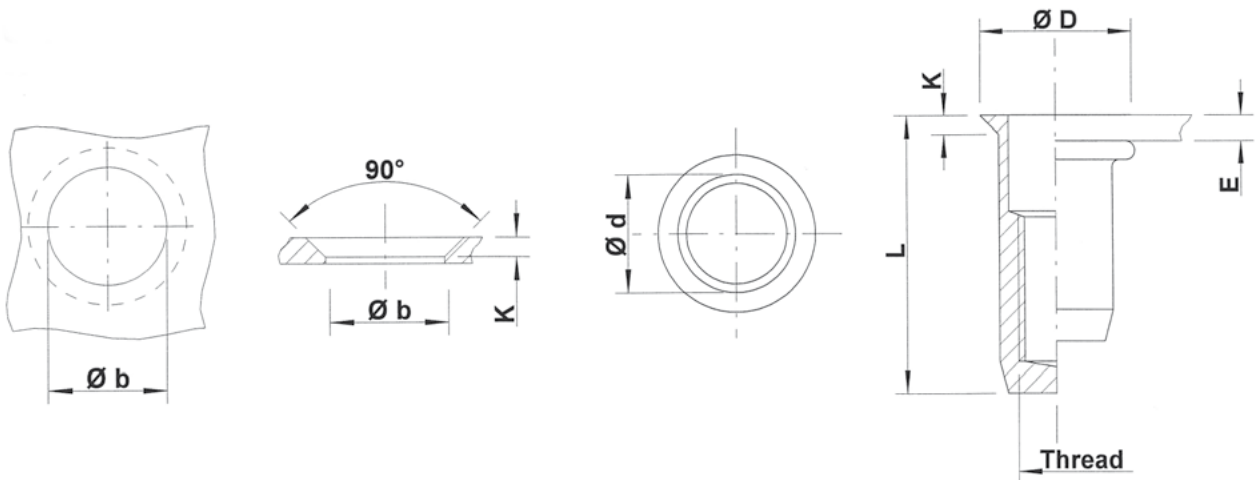

THREAD	TYPE	E = grip	L	b ^{+0,1} = drill dia	d = shank dia	D	K	kg/1000	ORDER CODE	BOX Small	BOX Large
M4	UFX30	1,2-3,0	16,0	6,0	6,0	8,0	1,0	2,0	554 210*	-	-
M5	UFX35	1,2-3,5	18,0	7,0	7,0	9,0	1,0	2,8	555 340	(500)	1000
M6	UFX45	1,7-4,5	24,0	9,0	9,0	12,0	1,5	6,7	556 260	(500)	750
M8	UFX45	1,7-4,5	25,0	11,0	11,0	14,0	1,5	9,3	558 150	-	500
M10	SFX45	1,7-4,5	30,5	13,0	13,0	16,0	1,5	14,3	550 615*	-	250

Small box: only for DFS customers, not export - (xxx) handling cost can be charged

* **Non-stock item:** minimum order quantity required after depletion of stock

All dimensions in mm - Technical data subject to modification

Tolerances and characteristics see chapter 'Technical Information'





Stainless Steel 316

(contains > 2% Molybden)

Round shank
Low profile head
Open end

UKO / SKO

extra high
corrosion resistance

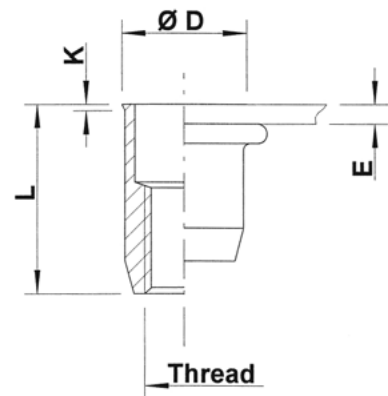
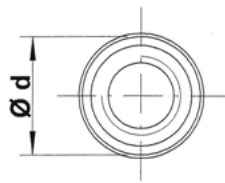
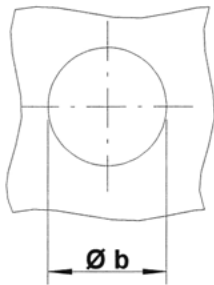

THREAD	TYPE	E = grip	L	b ^{+0,1} = drill dia	d = shank dia	D	K	kg/1000	ORDER CODE	BOX Small	BOX Large
M4	UKO20	0,5-2,0	11,0	6,0	6,0	6,5	0,5	1,1	554 220	(500)	3000
M5	UKO30	0,5-3,0	12,0	7,0	7,0	7,5	0,5	1,5	555 400	(500)	2000
	UKO50	3,0-5,0	15,0								
M6	UKO30	0,5-3,0	14,5	9,0	9,0	9,5	0,5	3,4	556 400	(500)	1000
	UKO50	3,0-5,0	16,5								
M8	UKO30	0,5-3,0	16,0	11,0	11,0	11,5	0,5	5,0	558 160	-	500
	UKO55	3,0-5,5	18,5								
M10	SKO35	0,8-3,5	21,0	13,0	13,0	13,5	0,7	8,5	550 620	(100)	500
	SKO60	3,5-6,0	23,5								

Small box: only for DFS customers, not export - (xxx) handling cost can be charged

All dimensions in mm - Technical data subject to modification

Tolerances and characteristics see chapter 'Technical Information'





Stainless Steel 316

(contains > 2% Molybden)

Round shank
Low profile head
Closed end

UKX

extra high
corrosion resistance

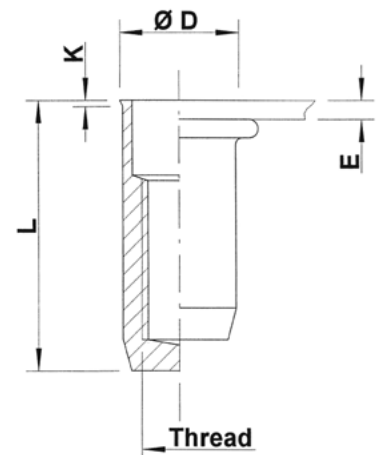
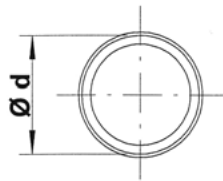

THREAD	TYPE	E = grip	L	b ^{+0,1} = drill dia	d = shank dia	D	K	kg/1000	ORDER CODE	BOX Small	BOX Large
M4	UKX20	0,5-2,0	15,5	6,0	6,0	6,5	0,5	1,9	554 250	(500)	2000
M5	UKX30	0,5-3,0	18,0	7,0	7,0	7,5	0,5	2,7	555 450	(500)	1500
M6	UKX30	0,5-3,0	21,5	9,0	9,0	9,5	0,5	5,8	556 450	(500)	1000
M8	UKX30	0,5-3,0	24,0	11,0	11,0	11,5	0,5	8,8	558 190	-	500

Small box: only for DFS customers, not export - (xxx) handling cost can be charged

M10: programme in progress

All dimensions in mm - Technical data subject to modification

Tolerances and characteristics see chapter 'Technical Information'





Stainless Steel 316

(contains > 2% Molybden)

Semi-hexagonal shank
Flat head
Open end

HUPO / HSPO

extra high
corrosion resistance

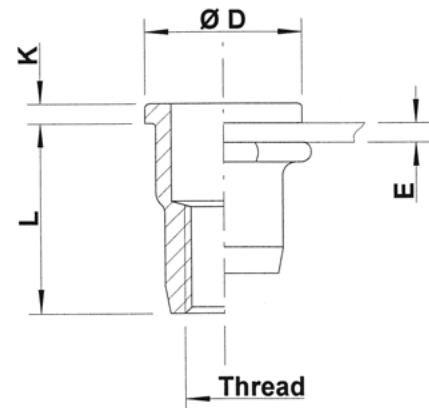
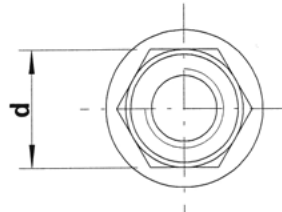
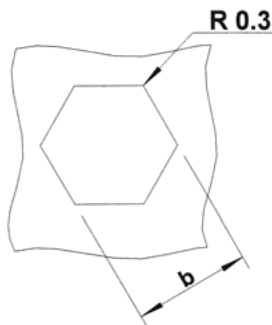

THREAD	TYPE	E = grip	L	b ^{+0,1} = hex hole	d = hex shank	D	K	kg/1000	ORDER CODE	BOX Small	BOX Large
M4	HUPO20	0,5-2,0	11,0	6,0	6,0	9,0	1,0	1,5	554 500	(500)	2500
M5	HUPO30	0,5-3,0	11,5	7,0	7,0	10,0	1,0	1,8	555 500	(500)	2000
	HUPO50	3,0-5,0	13,5						555 505*	-	-
M6	HUPO30	0,5-3,0	14,5	9,0	9,0	12,0	1,5	4,0	556 460	(500)	1000
	HUPO50	3,0-5,0	16,5						556 485*	-	1000
M8	HUPO30	0,5-3,0	16,0	11,0	11,0	15,0	1,5	6,1	558 250	-	500
	HUPO55	3,0-5,5	18,5						558 270*	-	500
M10	HSPO35	0,8-3,5	21,5	13,0	13,0	17,0	1,5	11,0	550 632	(100)	400
	HSPO60	3,5-6,0	24,0						550 633*	-	350

Small box: only for DFS customers, not export - (xxx) handling cost can be charged

* **Non-stock item:** minimum order quantity required after depletion of stock

All dimensions in mm - Technical data subject to modification
Tolerances and characteristics see chapter 'Technical Information'





Stainless Steel 316

(contains > 2% Molybden)

Semi-hexagonal shank
Flat head
Closed end

HUPX / HSPX

extra high
corrosion resistance

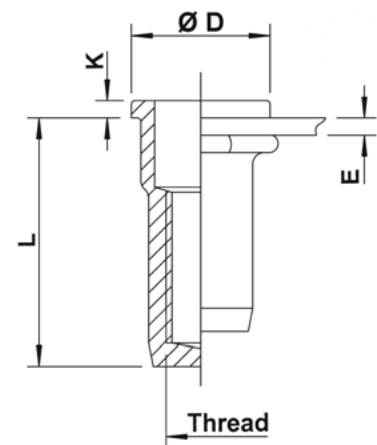
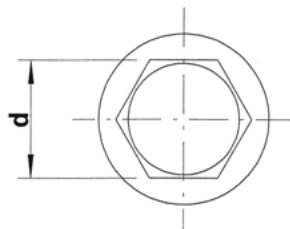
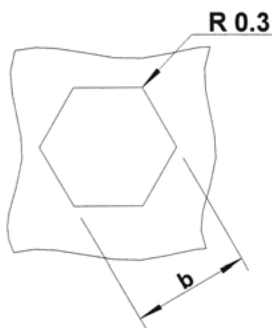

THREAD	TYPE	E = grip	L	b ^{+0,1} = hex hole	d = hex shank	D	K	kg/1000	ORDER CODE	BOX Small	BOX Large
M4	HUPX20	0,5-2,0	15,0	6,0	6,0	9,0	1,0	2,2	554 520	(500)	2000
M5	HUPX30	0,5-3,0	17,5	7,0	7,0	10,0	1,0	3,0	555 520	(500)	1500
	HUPX50	3,0-5,0	19,5					3,2	555 525	(500)	1200
M6	HUPX30	0,5-3,0	21,5	9,0	9,0	12,0	1,5	6,6	556 470	(500)	750
	HUPX50	3,0-5,0	23,5					6,9	556 475	(500)	750
M8	HUPX30	0,5-3,0	23,5	11,0	11,0	15,0	1,5	9,6	558 260	-	500
	HUPX55	3,0-5,5	26,0					10,0	558 280	-	500
M10	HSPX35	0,8-3,5	28,5	13,0	13,0	17,0	1,5	16,0	550 635	(100)	250
	HSPX60	3,5-6,0	31,0					17,0	550 636*	-	-

Small box: only for DFS customers, not export - (xxx) handling cost can be charged

* **Non-stock item:** minimum order quantity required after depletion of stock

All dimensions in mm - Technical data subject to modification

Tolerances and characteristics see chapter 'Technical Information'





Stainless Steel 316

(contains > 2% Molybden)

Semi-hexagonal shank
Low profile head
Open end

HUKO / HSKO

extra high
corrosion resistance

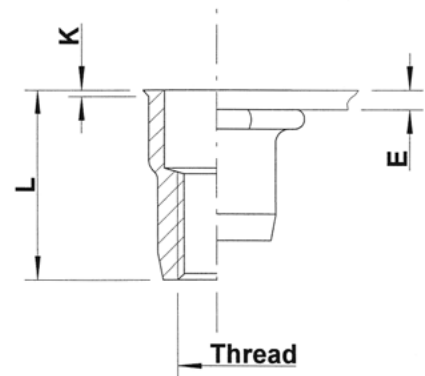
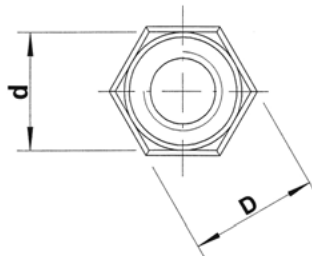
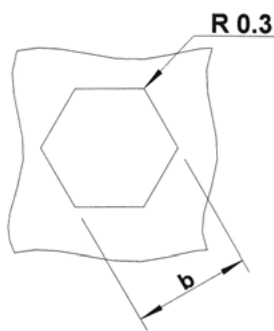

THREAD	TYPE	E = grip	L	b ^{+0,1} = hex hole	d = hex shank	D = hex head	K	kg/1000	ORDER CODE	BOX Small	BOX Large
M4	HUKO20	0,5-2,0	11,0	6,0	6,0	6,5	0,5	1,2	554 600	(500)	3000
M5	HUKO30	0,5-3,0	12,0	7,0	7,0	7,5	0,5	1,5	555 600	(500)	5000
	HUKO50	3,0-5,0	14,0							-	-
M6	HUKO30	0,5-3,0	14,5	9,0	9,0	9,7	0,5	3,3	556 500	(500)	1000
	HUKO50	3,0-5,0	16,5							-	1000
M8	HUKO30	0,5-3,0	16,0	11,0	11,0	11,8	0,5	4,9	558 300	500	2000
	HUKO55	3,0-5,5	18,5							-	750
M10	HSKO35	0,8-3,5	21,0	13,0	13,0	13,8	0,7	8,4	550 640	(100)	500
	HSKO60	3,5-6,0	23,5							(100)	300

Small box: only for DFS customers, not export - (xxx) handling cost can be charged

* **Non-stock item:** minimum order quantity required after depletion of stock

All dimensions in mm - Technical data subject to modification
Tolerances and characteristics see chapter 'Technical Information'





Stainless Steel 316

(contains > 2% Molybden)

Semi-hexagonal shank
Low profile head
Closed end

HUKX / HSKX

extra high
corrosion resistance

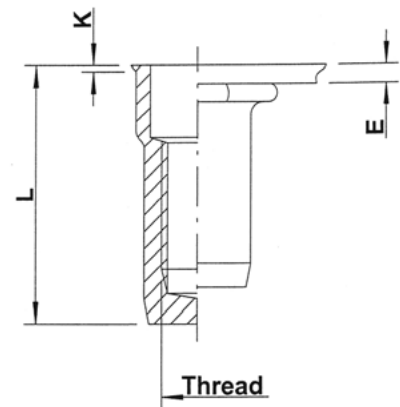
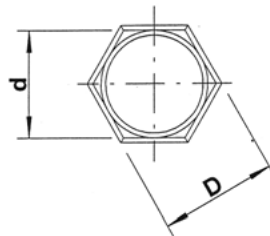
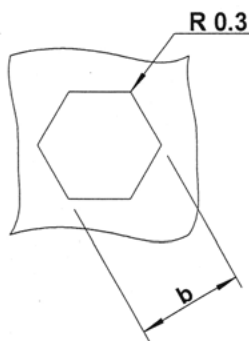

THREAD	TYPE	E = grip	L	b ^{+0,1} = hex hole	d = hex shank	D = hex head	K	kg/1000	ORDER CODE	BOX Small	BOX Large
M4	HUKX20	0,5-2,0	15,5	6,0	6,0	6,5	0,5	1,8	554 620	(500)	2500
M5	HUKX30	0,5-3,0	18,0	7,0	7,0	7,5	0,5	2,7	555 620	(500)	2000
	HUKX50	3,0-5,0	20,5					3,0	555 640	(500)	1500
M6	HUKX30	0,5-3,0	21,5	9,0	9,0	9,7	0,5	5,7	556 540	(500)	1000
	HUKX50	3,0-5,0	23,5					6,1	556 565	-	750
M8	HUKX30	0,5-3,0	24,0	11,0	11,0	11,8	0,5	8,7	558 320	-	500
	HUKX55	3,0-5,5	26,5					9,1	558 340	-	500
M10	HSKX35	0,8-3,5	29,5	13,0	13,0	13,8	0,7	14,2	550 660	-	-
	HSKX60	3,5-6,0	32,0					15,2	550 670	-	-
M12	HUKX70	4,0-7,0	39,0	16,0	16,0	17,5	1,1	28,7	552 880	(100)	300

Small box: only for DFS customers, not export - (xxx) handling cost can be charged

* **Non-stock item:** minimum order quantity required after depletion of stock

All dimensions in mm - Technical data subject to modification

Tolerances and characteristics see chapter 'Technical Information'





Steel

Round shank
Flat head
Open end

Zinktop 480h, Cr^{VI}- free

UPO / SPO

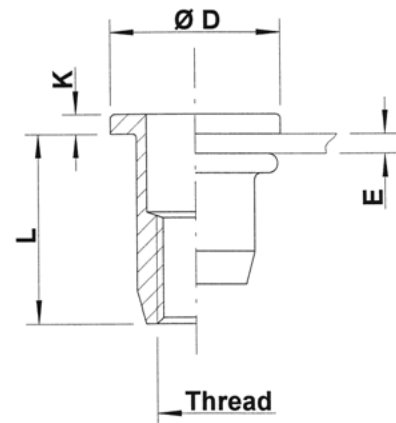
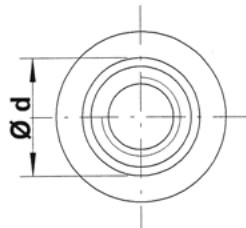
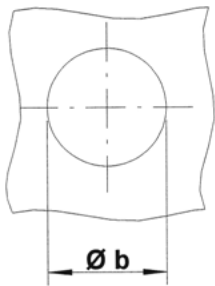

THREAD	TYPE	E = grip	L	b ^{+0,1} = drill dia	d = shank dia	D	K	kg/1000	ORDER CODE	BOX Small	BOX Large
M3	UPO20	0,5-2,0	9,75	5,0	5,0	8,0	0,75	1,0	523 029	2000 (2000)	10000 10000
	UPO30	2,0-3,0	10,75						523 049		
M4	UPO30	0,5-3,0	10,75	6,0	6,0	10,0	0,75	1,5	524 029	2000 (2000)	5000 5000
	UPO45	3,0-4,5	12,25						524 049		
M5	UPO30	0,5-3,0	12,0	7,0	7,0	11,0	1,0	2,1	525 029	2000 (2000)	4000 3000
	UPO55	3,0-5,5	15,0						525 049		
M6	UPO30	0,5-3,0	14,5	9,0	9,0	13,0	1,5	4,3	526 029	1000 (1000)	2000 2000
	UPO55	3,0-5,5	16,5						526 069		
	UPO80	5,5-8,0	19,0						526 089		
M8	UPO30	0,5-3,0	16,0	11,0	11,0	16,0	1,5	6,4	528 022	500 (500)	1250 1200
	UPO55	3,0-5,5	18,5						528 069		
	UPO80	5,5-8,0	21,5						528 089		
M10	UPO35	0,8-3,5	19,75	12,5	12,4	18,5	2,25	9,8	520 029	(400)	750 700
	UPO60	3,5-6,0	22,75						520 049		
M10	SPO35	0,8-3,5	21,0	13,0	13,0	19,0	2,0	11,4	520 609	(400)	750 500
	SPO60	3,5-6,0	24,0						520 629		
M12	UPO40	1,0-4,0	25,0	16,0	16,0	23,0	2,0	19,6	522 029	(200)	400 300
	UPO70	4,0-7,0	28,0						522 059		

Small box: only for DFS customers, not export - (xxx) handling cost can be charged

All dimensions in mm - Technical data subject to modification

Tolerances and characteristics see chapter 'Technical Information'





Steel

Round shank
Flat head
Closed end

Zinktop 480h, Cr^{VI}- free

UPX

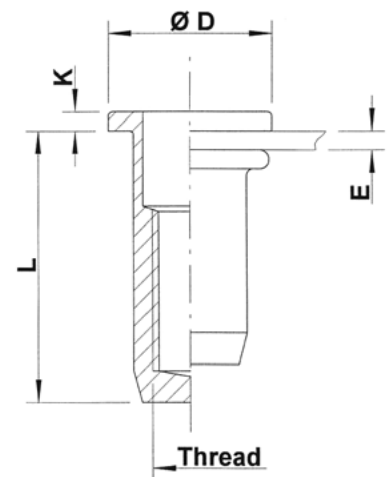
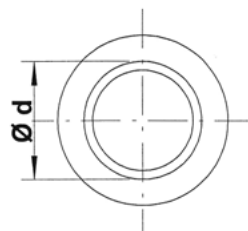
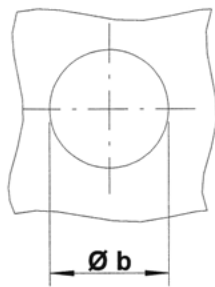

THREAD	TYPE	E = grip	L	b ^{+0,1} = drill dia	d = shank dia	D	K	kg/1000	ORDER CODE	BOX Small	BOX Large
M4	UPX30	0,5-3,0	14,75	6,0	6,0	10,0	0,75	2,1	524 189	(2000)	5000
	UPX45	3,0-4,5	16,25					2,1	524 229*	-	4000
M5	UPX30	0,5-3,0	18,0	7,0	7,0	11,0	1,0	3,4	525 169	(2000)	2500
	UPX55	3,0-5,5	20,5					3,6	525 189	(2000)	2500
M6	UPX30	0,5-3,0	21,5	9,0	9,0	13,0	1,5	6,8	526 169	(1000)	1500
	UPX55	3,0-5,5	24,5					7,1	526 209	(1000)	1250
	UPX80	5,5-8,0	27,0					7,4	526 239	-	-
M8	UPX30	0,5-3,0	22,5	11,0	11,0	16,0	1,5	10,1	528 189	(500)	1000
	UPX55	3,0-5,5	25,5					10,9	528 209	(500)	750
	UPX80	5,5-8,0	28,0					11,5	528 239	-	-
M10	UPX35	0,8-3,5	28,5	12,5	12,4	18,5	2,25	14,5	520 139	-	-
	UPX60	3,5-6,0	31,5					15,5	520 159*	-	-
M12	UPX70	3,0-7,0	38,0	16,0	16,0	23,0	2,0	30,0	522 209	-	-

Small box: only for DFS customers, not export - (xxx) handling cost can be charged

* **Non-stock item:** minimum order quantity required after depletion of stock

All dimensions in mm - Technical data subject to modification
Tolerances and characteristics see chapter 'Technical Information'





Steel

Round shank
Countersunk head
Open end

Zinktop 480h, Cr^{VI}- free

UFO

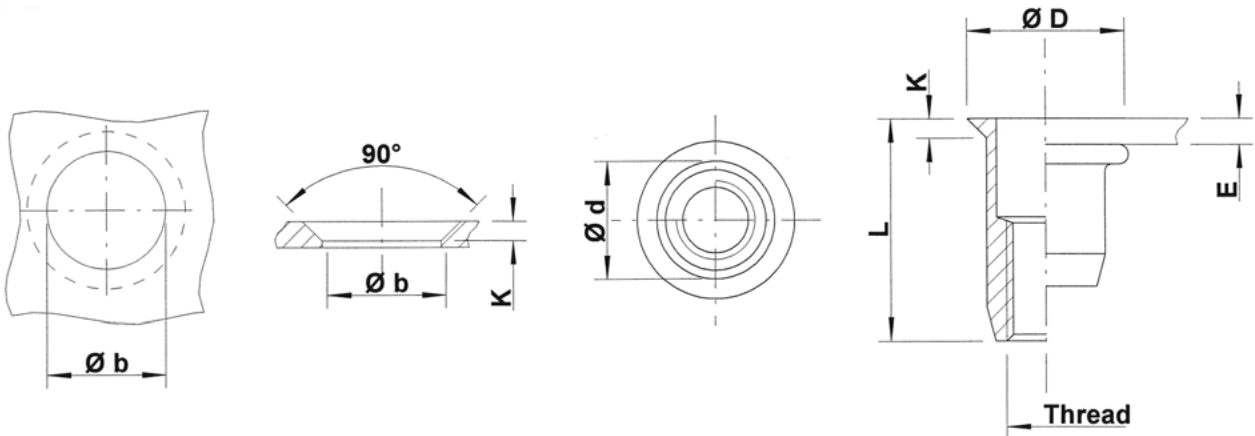

THREAD	TYPE	E = grip	L	b ^{+0,1} = drill dia	d = shank dia	D	K	kg/1000	ORDER CODE	BOX Small	BOX Large
M3	UFO35	1,7-3,5	11,25	5,0	5,0	8,0	1,5	1,1	523 209	(2000)	10000
M4	UFO35	1,7-3,5	11,5	6,0	6,0	9,0	1,5	1,3	524 309	2000	7500
	UFO50	3,5-5,0	13,0					1,5	524 329	(2000)	5000
M5	UFO40	1,7-4,0	13,0	7,0	7,0	10,0	1,5	2,0	525 269	2000	5000
	UFO65	4,0-6,5	16,0					2,3	525 289	(2000)	4000
M6	UFO45	1,7-4,5	17,0	9,0	9,0	12,0	1,5	4,2	526 309	1000	2000
	UFO65	4,5-6,5	19,0					4,7	526 329	(1000)	2000
M8	UFO45	1,7-4,5	19,0	11,0	11,0	14,0	1,5	6,3	528 269	500	1250
	UFO65	4,5-6,5	21,0					7,0	528 289	(500)	1250
M10	UFO45	1,7-4,5	21,0	12,5	12,4	15,4	1,5	7,6	520 229	(400)	1000
	UFO65	4,5-6,5	23,0					8,2	520 249	(400)	750
M12	UFO45	2,0-4,5	26,0	16,0	16,0	19,0	1,8	16,9	522 269	(200)	500
	UFO75	4,5-7,5	29,0					18,0	522 289	(200)	400

Small box: only for DFS customers, not export - (xxx) handling cost can be charged

All dimensions in mm - Technical data subject to modification
Tolerances and characteristics see chapter 'Technical Information'





Steel

Countersunk head
Round shank
Closed end

Zinktop 480h, Cr^{VI} - free

UFX

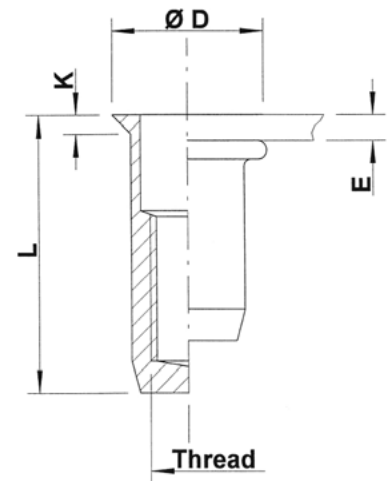
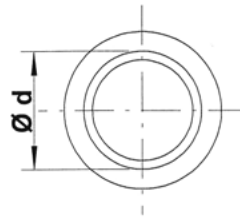
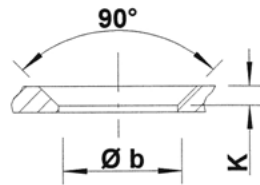
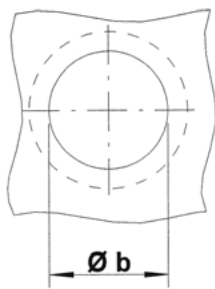

THREAD	TYPE	E = grip	L	b ^{+0,1} = drill dia	d = shank dia	D	K	kg/1000	ORDER CODE	BOX Small	BOX Large
M4	UFX35	1,7-3,5	15,5	6,0	6,0	9,0	1,5	2,0	524 449	(2000)	5000
	UFX50	3,5-5,0	17,0					2,2	524 469*	-	5000
M5	UFX40	1,7-4,0	18,0	7,0	7,0	10,0	1,5	3,0	525 389	(2000)	3000
	UFX65	4,0-6,5	20,5					3,4	525 409*	-	3000
M6	UFX45	1,7-4,5	22,0	9,0	9,0	12,0	1,5	6,1	526 409	(1000)	1500
	UFX65	4,5-6,5	24,0					6,5	526 429*	-	1500
M8	UFX45	1,7-4,5	25,0	11,0	11,0	14,0	1,5	9,2	528 369	(500)	1000
	UFX65	4,5-6,5	28,0					10,1	528 389*	-	750
M10	UFX45	1,7-4,5	29,5	12,5	12,4	15,4	1,5	12,3	520 269*	-	-

Small box: only for DFS customers, not export - (xxx) handling cost can be charged

* **Non-stock item:** minimum order quantity required after depletion of stock

All dimensions in mm - Technical data subject to modification

Tolerances and characteristics see chapter 'Technical Information'





Steel

Round shank
Low profile head
Open end

Zinktop 480h, Cr^{VI} - free

UKO

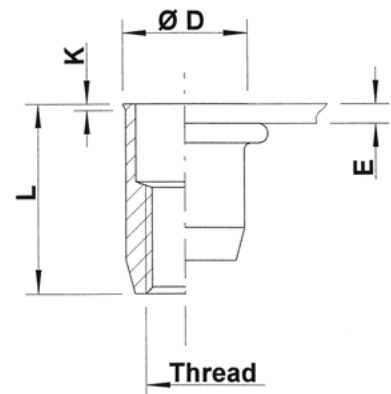
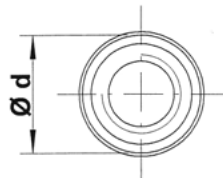
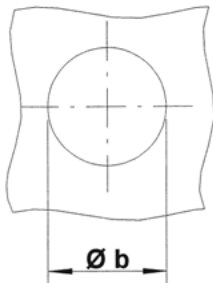

THREAD	TYPE	E = grip	L	b ^{+0,1} = drill dia	d = shank dia	D	K	kg/1000	ORDER CODE	BOX Small	BOX Large
M4	UKO30	0,5-3,0	10,75	6,0	6,0	6,5	0,5	1,1	524 529	2000	10000
	UKO50	3,0-5,0	12,75								
M5	UKO30	0,5-3,0	12,0	7,0	7,0	7,5	0,5	1,6	525 469	2000	5000
	UKO55	3,0-5,5	15,0								
M6	UKO30	0,5-3,0	14,5	9,0	9,0	9,5	0,5	3,4	526 469	1000	3000
	UKO55	3,0-5,5	16,5								
M8	UKO30	0,5-3,0	16,0	11,0	11,0	11,5	0,5	5,0	528 449	500	2000
	UKO55	3,0-5,5	18,5								
M10	UKO35	0,8-3,5	19,5	12,5	12,4	12,9	0,5	6,7	520 459	400	1250

Small box: only for DFS customers, not export - (xxx) handling cost can be charged

All dimensions in mm - Technical data subject to modification

Tolerances and characteristics see chapter 'Technical Information'





Steel

Round shank
Low profile head
Closed end

Zinktop 480h, Cr^{VI}- free

UKX

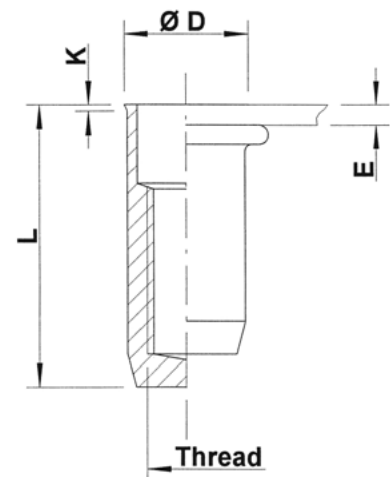
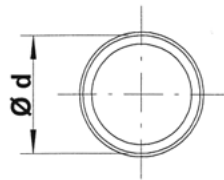
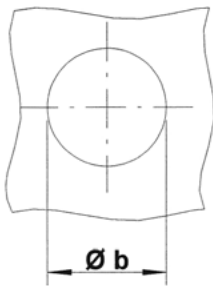

THREAD	TYPE	E = grip	L	b ^{+0,1} = drill dia	d = shank dia	D	K	kg/1000	ORDER CODE	BOX Small	BOX Large
M4	UKX30	0,5-3,0	15,0	6,0	6,0	6,5	0,5	1,8	524 579	(2000)	5000
M5	UKX30	0,5-3,0	18,0	7,0	7,0	7,5	0,5	2,8	525 559	(2000)	4000
M6	UKX30	0,5-3,0	21,5	9,0	9,0	9,5	0,5	5,8	526 519	(1000)	2000
M8	UKX30	0,5-3,0	22,5	11,0	11,0	11,5	0,5	8,3	528 479	(500)	1250
M10	UKX35	0,8-3,5	28,0	12,5	12,4	12,9	0,5	11,4	520 469*	-	-

Small box: only for DFS customers, not export - (xxx) handling cost can be charged

* **Non-stock item:** minimum order quantity required after depletion of stock

All dimensions in mm - Technical data subject to modification

Tolerances and characteristics see chapter 'Technical Information'





Steel

Knurled shank
Flat head
Open end

Zinktop 480h, Cr^{VI} - free

UPO KN / SPO KN

improved
nominal knurl

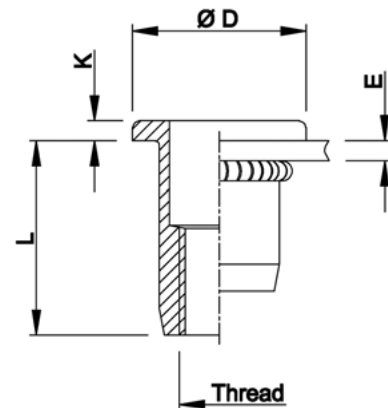
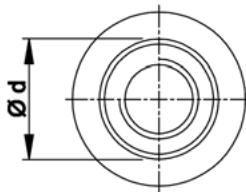
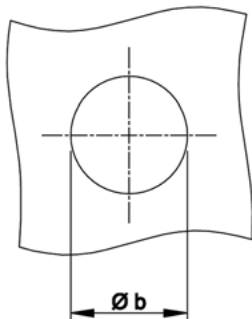

THREAD	TYPE	E = grip	L	b ^{+0,1} = drill dia	d = shank dia	D	K	kg/1000	ORDER CODE	BOX Small	BOX Large
M4	UPO30 KN	0,5-3,0	10,75	6,0	6,0	10,0	0,75	1,5	524 0297	(1000)	5000
	UPO45 KN	3,0-4,5	12,25						524 0497*	-	5000
M5	UPO30 KN	0,5-3,0	12,0	7,0	7,0	11,0	1,0	2,1	525 0297	(1000)	4000
	UPO55 KN	3,0-5,5	15,0						525 0497*	-	3000
M6	UPO30 KN	0,5-3,0	14,5	9,0	9,0	13,0	1,5	4,3	526 0297	(1000)	2000
	UPO55 KN	3,0-5,5	16,5						526 0697*	-	2000
M8	UPO30 KN	0,5-3,0	16,0	11,0	11,0	16,0	1,5	6,4	528 0227	(500)	1250
	UPO55 KN	3,0-5,5	18,5						528 0697*	-	1200
M10	SPO35 KN	0,8-3,5	21,0	13,0	13,0	19,0	2,0	11,4	520 6097*	-	750

Small box: only for DFS customers, not export - (xxx) handling cost can be charged

* **Non-stock item:** minimum order quantity required after depletion of stock

KN programme in progress

All dimensions in mm - Technical data subject to modification

Tolerances and characteristics see chapter 'Technical Information'





Steel

Knurled shank
Flat head
Closed end

Zinktop 480h, Cr^{VI}- free

UPX KN

improved
nominal knurl

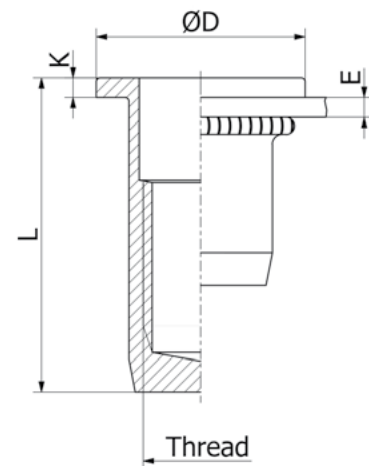
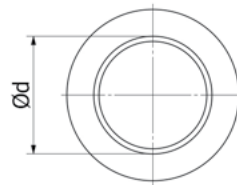
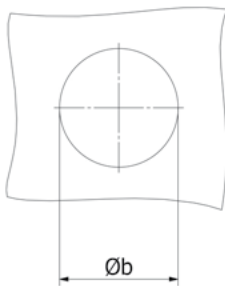

THREAD	TYPE	E = grip	L	b ^{+0,1} = drill dia	d = shank dia	D	K	kg/1000	ORDER CODE	BOX Small	BOX Large
M5	UPX30 KN	0,5-3,0	18,0	7,0	7,0	11,0	1,0	3,4	525 1697*	-	-
	UPX55 KN	3,0-5,5	20,5					3,6	525 1897*	-	-
M6	UPX30 KN	0,5-3,0	21,5	9,0	9,0	13,0	1,5	6,8	526 1697*	-	-
	UPX55 KN	3,0-5,5	24,5					7,1	526 2097*	-	-
M8	UPX30 KN	0,5-3,0	22,5	11,0	11,0	16,0	1,5	10,1	528 1897*	-	-
	UPX55 KN	3,0-5,5	25,5					10,9	528 2097*	-	-

Small box: only for DFS customers, not export - (xxx) handling cost can be charged

* **Non-stock item:** minimum order quantity required after depletion of stock

KN programme in progress

All dimensions in mm - Technical data subject to modification

Tolerances and characteristics see chapter 'Technical Information'





Steel

Knurled shank
Countersunk head with knurl
Open end

Zinktop 480h, Cr^{VI}- free

UFO KN / SFO KN

improved
nominal knurl

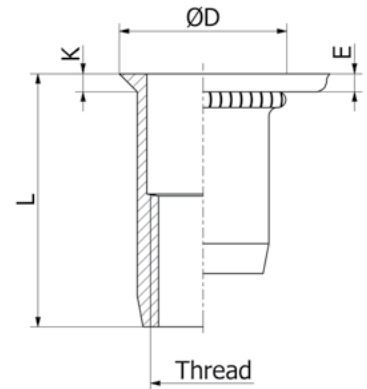
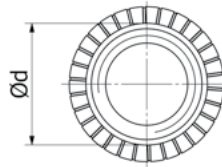
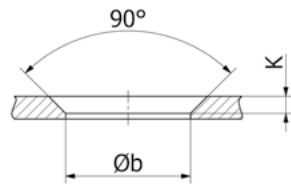
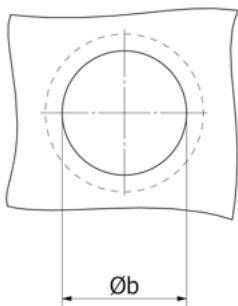

THREAD	TYPE	E = grip	L	b ^{+0,1} = drill dia	d = shank dia	D	K	kg/1000	ORDER CODE	BOX Small	BOX Large
M4	UFO35 KN	1,7-3,5	11,5	6,0	6,0	9,0	1,5	1,3	524 3097*	-	7500
M5	UFO40 KN	1,7-4,0	13,0	7,0	7,0	10,0	1,5	2,0	525 2697*	-	5000
M6	UFO45 KN	1,7-4,5	17,0	9,0	9,0	12,0	1,5	4,2	526 3097*	-	2000
M8	UFO45 KN	1,7-4,5	19,0	11,0	11,0	14,0	1,5	6,3	528 2697*	-	1250
M10	SFO45 KN	1,7-4,5	21,0	13,0	13,0	16,0	1,5	10,0	520 2297*	-	-

Small box: only for DFS customers, not export - (xxx) handling cost can be charged

* **Non-stock item:** minimum order quantity required after depletion of stock

KN programme in progress

All dimensions in mm - Technical data subject to modification
Tolerances and characteristics see chapter 'Technical Information'



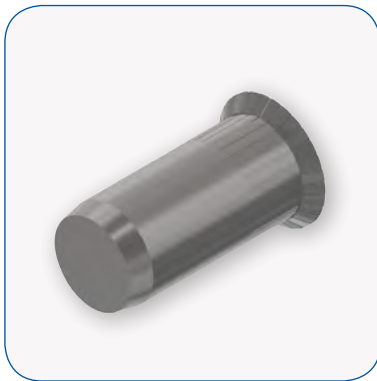

Steel

Knurled shank
Countersunk head with knurl
Closed end

Zinktop 480h, Cr^{VI}- free

UFX KN / SFX KN

improved
nominal knurl

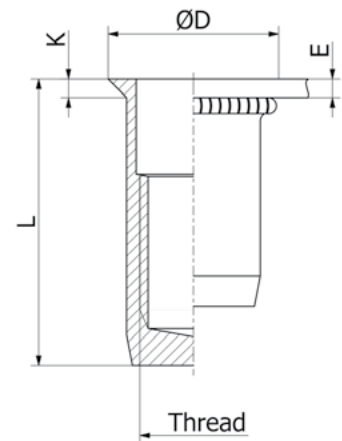
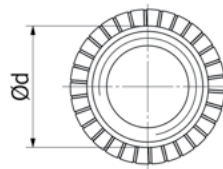
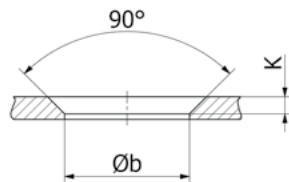
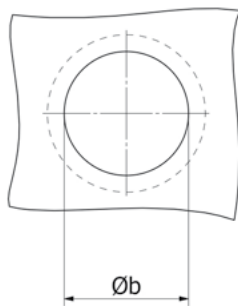

THREAD	TYPE	E = grip	L	b ^{+0,1} = drill dia	d = shank dia	D	K	kg/1000	ORDER CODE	BOX Small	BOX Large
M4	UFX35 KN	1,7-3,5	11,5	6,0	6,0	9,0	1,5	2,0	524 4497*	-	-
M5	UFX40 KN	1,7-4,0	13,0	7,0	7,0	10,0	1,5	3,0	525 3897*	-	-
M6	UFX45 KN	1,7-4,5	17,0	9,0	9,0	12,0	1,5	6,1	526 4097*	-	-
M8	UFX45 KN	1,7-4,5	19,0	11,0	11,0	14,0	1,5	9,2	528 3697*	-	-
M10	SFX45 KN	1,7-4,5	21,0	13,0	13,0	16,0	1,5	15,7	520 8197*	-	-

Small box: only for DFS customers, not export - (xxx) handling cost can be charged

* **Non-stock item:** minimum order quantity required after depletion of stock

KN programme in progress

All dimensions in mm - Technical data subject to modification

Tolerances and characteristics see chapter 'Technical Information'





Steel

Knurled shank
Low profile head
Open end

Zinktop 480h, Cr^{VI}- free

UKO KN / SKO KN

improved
nominal knurl

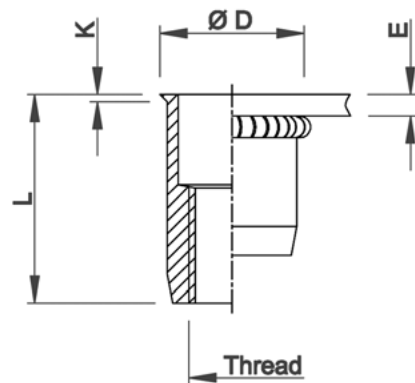
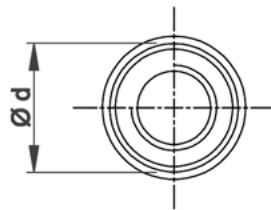

THREAD	TYPE	E = grip	L	b ^{+0,1} = drill dia	d = shank dia	D	K	kg/1000	ORDER CODE	BOX Small	BOX Large
M4	UKO30 KN	0,5-3,0	10,75	6,0	6,0	6,5	0,5	1,1	524 5297	(2000)	10000
	UKO50 KN	3,0-5,0	12,75	6,0	6,0	6,5	0,5	1,2	524 5397*	-	7500
M5	UKO30 KN	0,5-3,0	12,0	7,0	7,0	7,5	0,5	1,6	525 4697	(2000)	5000
	UKO55 KN	3,0-5,5	15,0	7,0	7,0	7,5	0,5	1,8	525 4897*	-	4000
M6	UKO30 KN	0,5-3,0	14,5	9,0	9,0	9,5	0,5	3,4	526 4697	(1000)	3000
	UKO55 KN	3,0-5,5	16,5	9,0	9,0	9,5	0,5	3,7	526 4897*	-	2500
M8	UKO30 KN	0,5-3,0	16,0	11,0	11,0	11,5	0,5	5,0	528 4497	(500)	2000
	UKO55 KN	3,0-5,5	18,5	11,0	11,0	11,5	0,5	5,5	528 4597*	-	1500
M10	SKO35 KN	0.8-3.5	19,5	13,0	13,0	13,5	0,5	9,2	520 8497*	-	-

Small box: only for DFS customers, not export - (xxx) handling cost can be charged

* **Non-stock item:** minimum order quantity required after depletion of stock

KN programme in progress

All dimensions in mm - Technical data subject to modification

Tolerances and characteristics see chapter 'Technical Information'



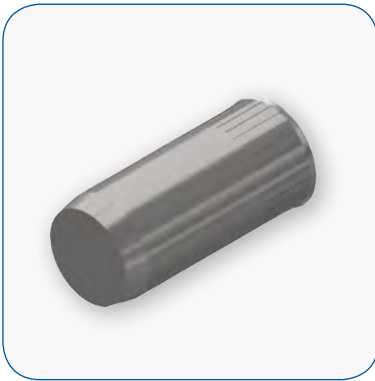

Steel

Knurled shank
Low profile head
Closed end

Zinktop 480h, Cr^{VI}- free

UKX KN

improved
nominal knurl

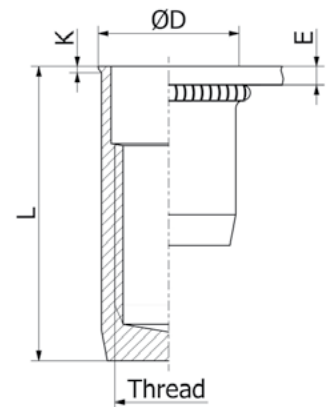
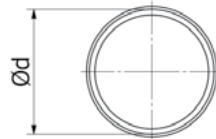
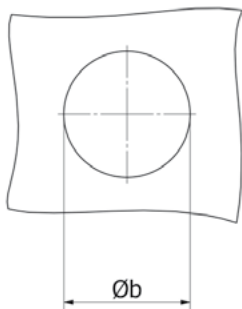

THREAD	TYPE	E = grip	L	b ^{+0,1} = drill dia	d = shank dia	D	K	kg/1000	ORDER CODE	BOX Small	BOX Large
M5	UKX30 KN	0,5-3,0	18,0	7,0	7,0	7,5	0,5	2,8	525 5597*	-	-
	UKX55 KN	3,0-5,5	20,5	7,0	7,0	7,5	0,5	3,0	525 5297*	-	-
M6	UKX30 KN	0,5-3,0	21,5	9,0	9,0	9,5	0,5	5,8	526 5197*	-	-
	UKX55 KN	3,0-5,5	24,0	9,0	9,0	9,5	0,5	6,0	526 5097*	-	-
M8	UKX30 KN	0,5-3,0	22,5	11,0	11,0	11,5	0,5	8,3	528 4797*	-	-
	UKX55 KN	3,0-5,5	25,0	11,0	11,0	11,5	0,5	8,7	528 4697*	-	-

Small box: only for DFS customers, not export - (xxx) handling cost can be charged

* **Non-stock item:** minimum order quantity required after depletion of stock

KN programme in progress

All dimensions in mm - Technical data subject to modification

Tolerances and characteristics see chapter 'Technical Information'





Steel

Full-hexagonal shank⁽¹⁾
 Flat head
 Open end

Zinktop 480h, Cr^{VI}- free

HUPO / HSPO

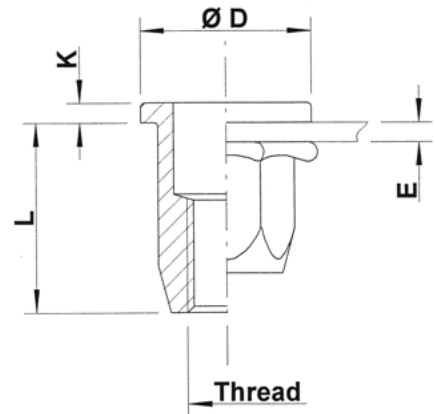
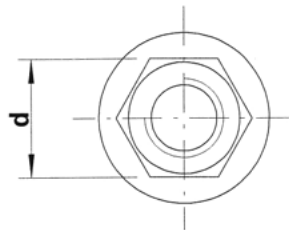
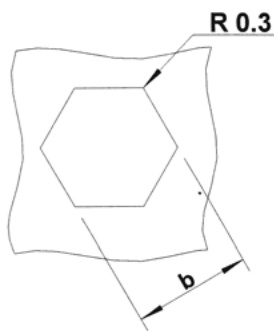

THREAD	TYPE	E = grip	L	b ^{+0,1} = hex hole	d = hex shank	D	K	kg/1000	ORDER CODE	BOX Small	BOX Large
M4	HUPO20	0,5-2,0	10,0	6,0	6,0	9,0	1,0	1,4	524 589	2000	7000
M5	HUPO30	0,5-3,0	13,0	7,0	7,0	10,0	1,0	2,3	525 569	(2000)	4000
	HUPO55	3,0-5,5	15,5					2,4	525 579	-	-
M6	HUPO30	0,5-3,0	14,5	9,0	9,0	13,0	1,5	4,7	526 529	1000	2000
	HUPO55	3,0-5,5	16,5					4,8	526 549	(1000)	1750
M8	HUPO30	0,5-3,0	16,5	11,0	11,0	16,0	1,5	7,0	528 482	(500)	1200
	HUPO55	3,0-5,5	19,0					7,5	528 509	(500)	1000
	HUPO80	5,5-8,0	22,0					8,1	528 609	(500)	750
M10	HSPO35	0,8-3,5	21,0	13,0	13,0	19,0	2,0	11,6	520 649	(400)	700
	HSPO60	3,5-6,0	23,5					12,3	520 659	(400)	500
M12 ⁽¹⁾	HUPO40	1,0-4,0	25,0	16,0	16,0	23,0	2,0	19,6	522 509	(200)	350

Small box: only for DFS customers, not export - (xxx) handling cost can be charged

⁽¹⁾ Except M12: semi-hexagonal shank

All dimensions in mm - Technical data subject to modification
 Tolerances and characteristics see chapter 'Technical Information'

Semi-hexagonal programme available on demand





Steel

Full-hexagonal shank
Flat head
Closed end

Zinktop 480h, Cr^{VI} - free

HUPX / HSPX

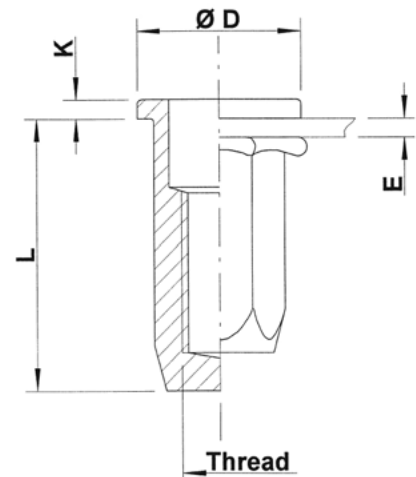
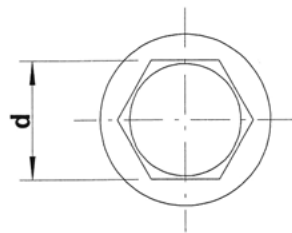
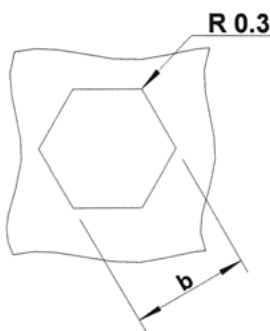

THREAD	TYPE	E = grip	L	b ^{+0,1} = hex hole	d = hex shank	D	K	kg/1000	ORDER CODE	BOX Small	BOX Large
M4	HUPX20	0,5-2,0	14,5	6,0	6,0	9,0	1,0	2,2	524 609	(1000)	5000
M5	HUPX30	0,5-3,0	19,0	7,0	7,0	10,0	1,0	3,6	525 589	(1000)	2500
	HUPX55	3,0-5,5	21,5					3,9	525 599	(1000)	2500
M6	HUPX30	0,5-3,0	21,5	9,0	9,0	13,0	1,5	7,4	526 569	(500)	1250
	HUPX55	3,0-5,5	23,5					7,6	526 579	(500)	1250
M8	HUPX30	0,5-3,0	24,5	11,0	11,0	16,0	1,5	11,6	528 529	(500)	750
	HUPX55	3,0-5,5	27,0					12,2	528 539	(500)	700
M10	HSPX35	0,8-3,5	31,0	13,0	13,0	19,0	2,0	19,0	520 654	-	400
	HSPX60	3,5-6,0	33,5					19,4	520 658	-	400

Small box: only for DFS customers, not export - (xxx) handling cost can be charged

All dimensions in mm - Technical data subject to modification

Tolerances and characteristics see chapter 'Technical Information'

Semi-hexagonal programme available on demand





Steel

Full-hexagonal shank
Low profile head
Open end

Zinktop 480h, Cr^{VI}- free

HUKO / HSKO

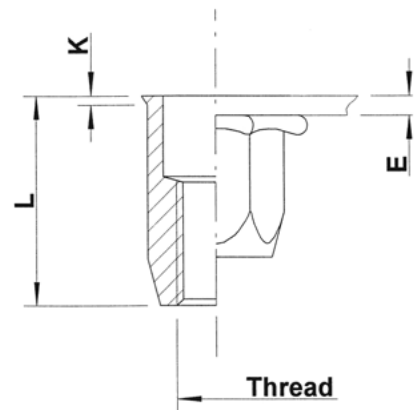
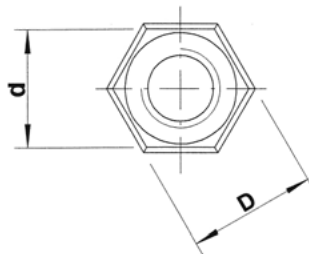
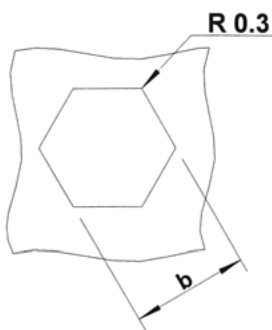

THREAD	TYPE	E = grip	L	b ^{+0,1} = hex hole	d = hex shank	D = hex head	K	kg/1000	ORDER CODE	BOX Small	BOX Large
M4	HUKO20	0,5-2,0	11,0	6,0	6,0	6,6	0,6	1,2	524 629	2000	7500
M5	HUKO30	0,5-3,0	14,0	7,0	7,0	7,7	0,6	2,0	525 609	2000	5000
	HUKO55	3,0-5,5	16,5					2,3	525 629	(2000)	4000
M6	HUKO30	0,5-3,0	16,0	9,0	9,0	9,8	0,7	4,2	526 589	1000	2500
	HUKO55	3,0-5,5	18,5					4,6	526 609	(1000)	2000
M8	HUKO30	0,5-3,0	18,0	11,0	11,0	11,8	0,7	6,2	528 549	500	1250
	HUKO55	3,0-5,5	20,5					6,9	528 569	(500)	1250
	HUKO80	5,5-8,0	23,0					7,6	528 579*	-	-
M10	HSKO35	0,8-3,5	23,0	13,0	13,0	13,8	0,7	10,5	520 669	(400)	750
	HSKO60	3,5-6,0	25,5					11,0	520 679	(400)	700

Small box: only for DFS customers, not export - (xxx) handling cost can be charged

* **Non-stock item:** minimum order quantity required after depletion of stock

All dimensions in mm - Technical data subject to modification

Tolerances and characteristics see chapter 'Technical Information'

Semi-hexagonal programme available on demand





Steel

Full-hexagonal shank
Low profile head
Closed end

Zinktop 480h, Cr^{VI} - free

HUKX / HSKX

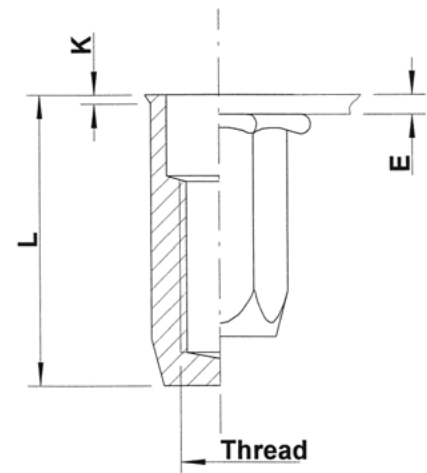
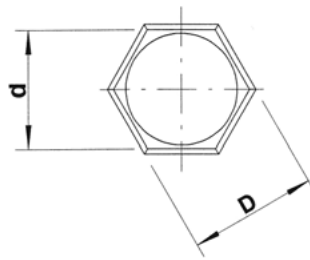
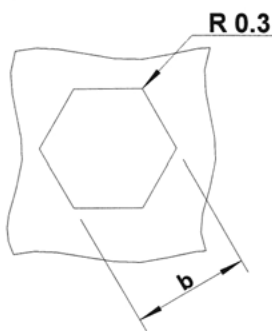

THREAD	TYPE	E = grip	L	b ^{+0,1} = hex hole	d = hex shank	D = hex head	K	kg/1000	ORDER CODE	BOX Small	BOX Large
M4	HUKX20	0,5-2,0	15,5	6,0	6,0	6,6	0,6	2,0	524 649	2000	5000
M5	HUKX30	0,5-3,0	20,0	7,0	7,0	7,7	0,6	3,3	525 649	2000	3000
	HUKX55	3,0-5,5	22,5					3,6	525 659	-	2000
M6	HUKX30	0,5-3,0	22,0	9,0	9,0	9,8	0,7	6,6	526 629	1000	1750
	HUKX55	3,0-5,5	24,5					6,9	526 639	(1000)	1250
M8	HUKX30	0,5-3,0	25,0	11,0	11,0	11,8	0,7	10,5	528 589	(500)	1000
	HUKX55	3,0-5,5	27,5					10,7	528 590	(500)	750
M10	HSKX35	0,8-3,5	32,0	13,0	13,0	13,8	0,7	18,9	520 645	-	400

Small box: only for DFS customers, not export - (xxx) handling cost can be charged

All dimensions in mm - Technical data subject to modification

Tolerances and characteristics see chapter 'Technical Information'

Semi-hexagonal programme available on demand





Steel

Splined shank
Flat head
Open end

Zinktop 480h, Cr^{VI} - free

UPO RS

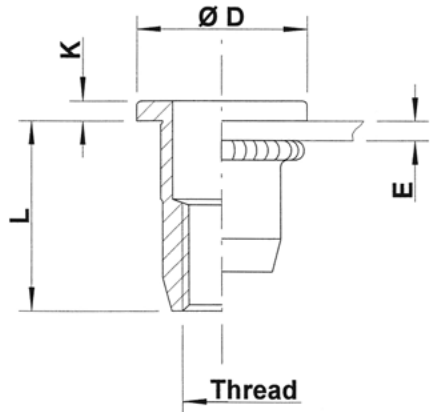
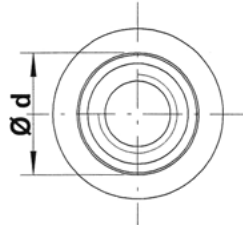
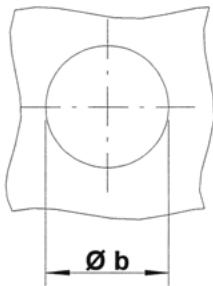

THREAD	TYPE	E = grip	L	b ^{+0,1} = drill dia	d = splined shank	D	K	kg/1000	ORDER CODE	BOX Small	BOX Large
M4	UPO30 RS	0,5-3,0	10,75	6,4	6,3	10,0	0,75	1,5	524 709	2000	5000
	UPO45 RS	3,0-4,5	12,25						524 729*	-	5000
M5	UPO30 RS	0,5-3,0	12,0	7,4	7,3	11,0	1,0	2,2	525 709	(2000)	4000
	UPO55 RS	3,0-5,5	15,0						525 729	(2000)	3000
M6	UPO30 RS	0,5-3,0	14,5	9,4	9,3	13,0	1,5	4,4	526 709	(1000)	2000
	UPO55 RS	3,0-5,5	16,5						526 729	(1000)	2000
M8	UPO30 RS	0,5-3,0	16,0	11,5	11,4	16,0	1,5	6,5	528 709	(500)	1250
	UPO55 RS	3,0-5,5	18,5						528 729	(500)	1200
M10	UPO35 RS	0,8-3,5	19,75	13,0	12,9	18,5	2,25	10,0	520 709	(400)	750
	UPO60 RS	3,5-6,0	22,75						520 729	(400)	700

Small box: only for DFS customers, not export - (xxx) handling cost can be charged

* **Non-stock item:** minimum order quantity required after depletion of stock

All dimensions in mm - Technical data subject to modification

Tolerances and characteristics see chapter 'Technical Information'





Steel

Splined shank
Countersunk head
Open end

Zinktop 480h, Cr^{VI} - free

UFO RS

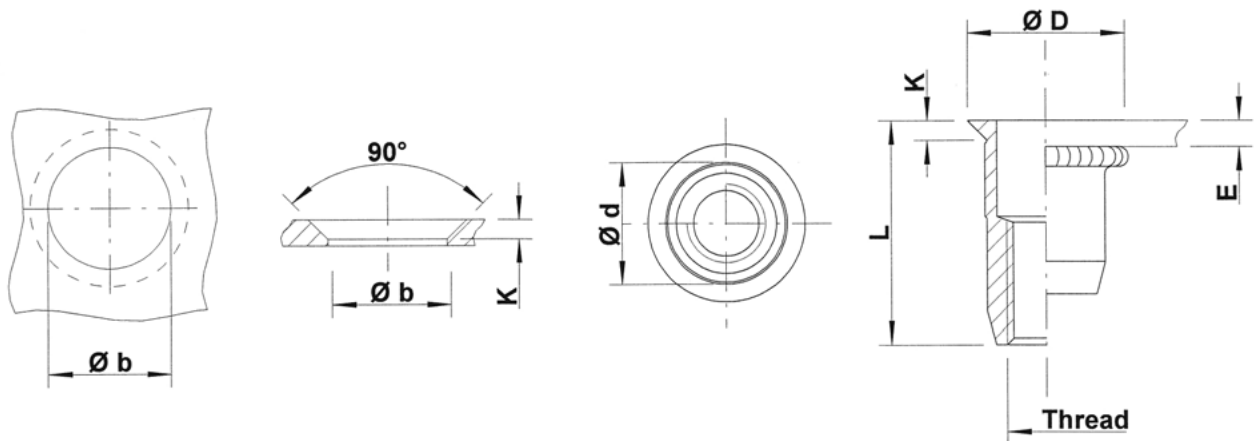

THREAD	TYPE	E = grip	L	b ^{+0,1} = drill dia	d = splined shank	D	K	kg/1000	ORDER CODE	BOX Small	BOX Large
M4	UFO35 RS	1,7-3,5	11,5	6,4	6,3	9,0	1,5	1,4	524 749	(2000)	7500
	UFO50 RS	3,5-5,0	13,0					1,5	524 769*	-	5000
M5	UFO40 RS	1,7-4,0	13,0	7,4	7,3	10,0	1,5	2,1	525 749	(2000)	5000
	UFO65 RS	4,0-6,5	16,0					2,4	525 769*	-	4000
M6	UFO45 RS	1,7-4,5	17,0	9,4	9,3	12,0	1,5	4,4	526 769	(1000)	2000
	UFO65 RS	4,5-6,5	19,0					4,7	526 789	(1000)	2000
M8	UFO45 RS	1,7-4,5	19,0	11,5	11,4	14,0	1,5	6,4	528 749	(500)	1250
	UFO65 RS	4,5-6,5	21,0					6,8	528 769	(500)	1250
M10	UFO45 RS	1,7-4,5	21,0	13,0	12,9	15,4	1,5	7,9	520 749	(400)	750
	UFO65 RS	4,5-6,5	23,0					8,5	520 769	(400)	750

Small box: only for DFS customers, not export - (xxx) handling cost can be charged

* **Non-stock item:** minimum order quantity required after depletion of stock

All dimensions in mm - Technical data subject to modification

Tolerances and characteristics see chapter 'Technical Information'





Aluminium

Round shank
Flat head
Open end
UPO

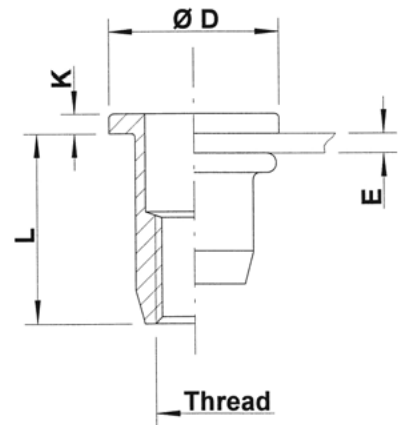
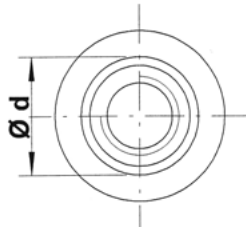
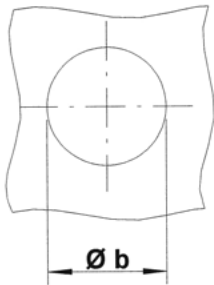

THREAD	TYPE	E = grip	L	b ^{+0,1} = drill dia	d = shank dia	D	K	kg/1000	ORDER CODE	BOX Small	BOX Large
M3	UPO20	0,5-2,0	9,75	5,0	5,0	8,0	0,75	0,4	513 050	(2000)	10000
	UPO30	2,0-3,0	10,75						513 100	(2000)	10000
M4	UPO30	0,5-3,0	10,75	6,0	6,0	10,0	0,75	0,5	514 025	2000	5000
	UPO45	3,0-4,5	12,25						514 050	(2000)	5000
M5	UPO30	0,5-3,0	12,0	7,0	7,0	11,0	1,0	0,7	515 025	(2000)	4000
	UPO55	3,0-5,5	15,0						515 050	(2000)	3000
M6	UPO30	0,5-3,0	14,5	9,0	9,0	13,0	1,5	1,5	516 025	(1000)	2000
	UPO55	3,0-5,5	16,5						516 075	(1000)	2000
	UPO80	5,5-8,0	19,0					516 090*	-	1500	
M8	UPO30	0,5-3,0	16,0	11,0	11,0	16,0	1,5	2,2	518 025	(500)	1250
	UPO55	3,0-5,5	18,5						518 050	(500)	1250
	UPO80	5,5-8,0	21,5					518 055*	-	1000	
M10	UPO35	0,8-3,5	19,75	12,5	12,4	18,5	2,25	3,3	510 025	(400)	750
	UPO60	3,5-6,0	22,75						510 050*	-	700

Small box: only for DFS customers, not export - (xxx) handling cost can be charged

* **Non-stock item:** minimum order quantity required after depletion of stock

All dimensions in mm - Technical data subject to modification
Tolerances and characteristics see chapter 'Technical Information'





Aluminium

Round shank
Flat head
Closed end

UPX

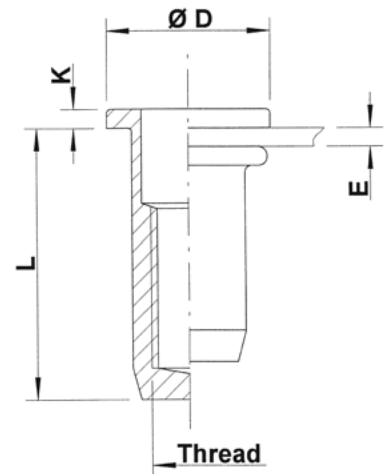
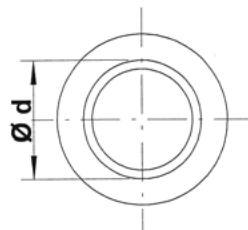

THREAD	TYPE	E = grip	L	b ^{+0,1} = drill dia	d = shank dia	D	K	kg/1000	ORDER CODE	BOX Small	BOX Large
M3	UPX20	0,5-2,0	13,25	5,0	5,0	8,0	0,75	0,5	513 400*	-	7500
M4	UPX30	0,5-3,0	14,75	6,0	6,0	10,0	0,75	0,7	514 200	(2000)	5000
	UPX45	3,0-4,5	16,25					0,7	514 225*	-	4000
M5	UPX30	0,5-3,0	18,0	7,0	7,0	11,0	1,0	1,1	515 175	(2000)	2500
	UPX55	3,0-5,5	20,5					1,2	515 200*	-	2500
M6	UPX30	0,5-3,0	21,5	9,0	9,0	13,0	1,5	2,3	516 175	(1000)	1500
	UPX55	3,0-5,5	24,5					2,5	516 200*	-	1500
M8	UPX30	0,5-3,0	22,5	11,0	11,0	16,0	1,5	3,5	518 125	(500)	750
	UPX55	3,0-5,5	25,5					3,9	518 150*	-	750

Small box: only for DFS customers, not export - (xxx) handling cost can be charged

* **Non-stock item:** minimum order quantity required after depletion of stock

All dimensions in mm - Technical data subject to modification

Tolerances and characteristics see chapter 'Technical Information'





Aluminium

Round shank
Countersunk head
Open end

UFO

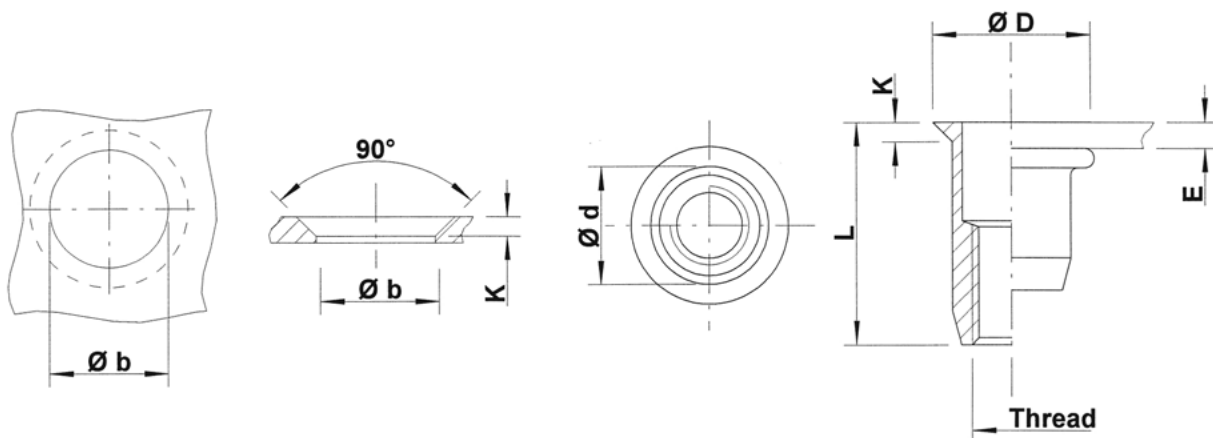

THREAD	TYPE	E = grip	L	b ^{+0,1} = drill dia	d = shank dia	D	K	kg/1000	ORDER CODE	BOX Small	BOX Large
M3	UFO35	1,7-3,5	11,25	5,0	5,0	8,0	1,5	0,4	513 550	(2000)	10000
M4	UFO35	1,7-3,5	11,5	6,0	6,0	9,0	1,5	0,5	514 350	(2000)	7500
	UFO50	3,5-5,0	13,0						514 375	(2000)	5000
M5	UFO40	1,7-4,0	13,0	7,0	7,0	10,0	1,5	0,7	515 250	(2000)	5000
	UFO65	4,0-6,5	16,0						515 275	(2000)	4000
M6	UFO45	1,7-4,5	17,0	9,0	9,0	12,0	1,5	1,5	516 250	(1000)	2000
	UFO65	4,5-6,5	19,0						516 275	(1000)	2000
M8	UFO45	1,7-4,5	19,0	11,0	11,0	14,0	1,5	2,1	518 175	(500)	1250
	UFO65	4,5-6,5	21,0						518 200	(500)	1250
M10	UFO45	1,7-4,5	21,0	12,5	12,4	15,4	1,5	2,5	510 250	(500)	1000
	UFO65	4,5-6,5	23,0						510 275*	(500)	1000

Small box: only for DFS customers, not export - (xxx) handling cost can be charged

* Non-stock item: minimum order quantity required after depletion of stock

All dimensions in mm - Technical data subject to modification
Tolerances and characteristics see chapter 'Technical Information'





Aluminium

Round shank
Countersunk head
Closed end

UFX

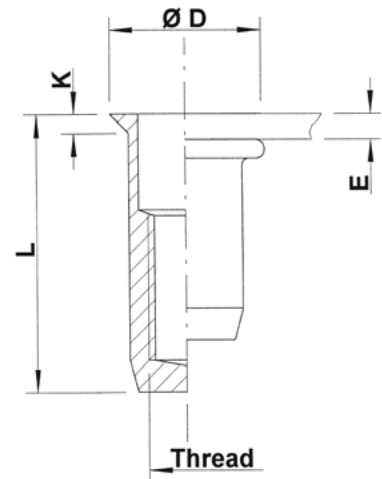
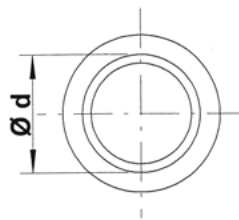
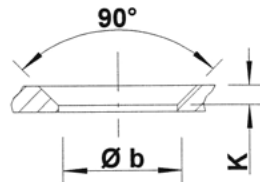
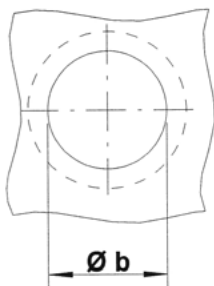

THREAD	TYPE	E = grip	L	b ^{+0,1} = drill dia	d = shank dia	D	K	kg/1000	ORDER CODE	BOX Small	BOX Large
M4	UFX35	1,7-3,5	15,5	6,0	6,0	9,0	1,5	0,7	514 450	(2000)	5000
	UFX50	3,5-5,0	17,0	6,0	6,0	9,0	1,5	0,7	514 475*	-	5000
M5	UFX40	1,7-4,0	18,0	7,0	7,0	10,0	1,5	1,0	515 375	(2000)	3000
	UFX65	4,0-6,5	20,5	7,0	7,0	10,0	1,5	1,1	515 400*	-	3000
M6	UFX45	1,7-4,5	22,0	9,0	9,0	12,0	1,5	2,1	516 400	(1000)	1500
	UFX65	4,5-6,5	24,0	9,0	9,0	12,0	1,5	2,3	516 425*	-	1500
M8	UFX45	1,7-4,5	25,0	11,0	11,0	14,0	1,5	3,3	518 325*	-	1000
	UFX65	4,5-6,5	28,0	11,0	11,0	14,0	1,5	3,7	518 350*	-	750

Small box: only for DFS customers, not export - (xxx) handling cost can be charged

* **Non-stock item:** minimum order quantity required after depletion of stock

All dimensions in mm - Technical data subject to modification

Tolerances and characteristics see chapter 'Technical Information'





Aluminium

Round shank
Low profile head
Open end

UKO

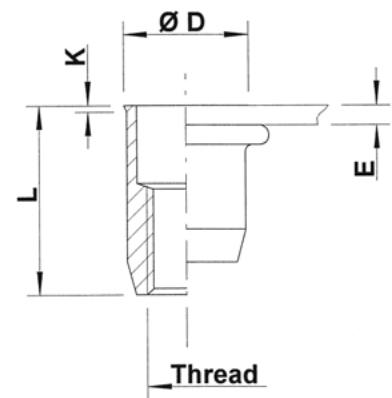
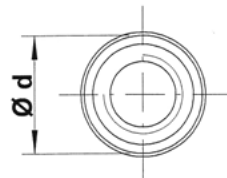
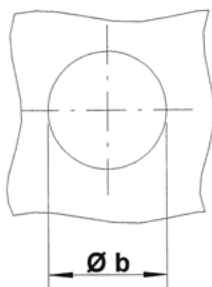

THREAD	TYPE	E = grip	L	b ^{+0,1} = drill dia	d = shank dia	D	K	kg/1000	ORDER CODE	BOX Small	BOX Large
M4	UKO30	0,5-3,0	10,75	6,0	6,0	6,5	0,5	0,4	514 525	(2000)	10000
M5	UKO30	0,5-3,0	12,0	7,0	7,0	7,5	0,5	0,5	515 500	(2000)	5000
M6	UKO30	0,5-3,0	14,5	9,0	9,0	9,5	0,5	1,2	516 500	(1000)	3000
M8	UKO30	0,5-3,0	16,0	11,0	11,0	11,5	0,5	1,8	518 450	(500)	2000

Small box: only for DFS customers, not export - (xxx) handling cost can be charged

All dimensions in mm - Technical data subject to modification
Tolerances and characteristics see chapter 'Technical Information'



Trusted and carefree watertight Tubtara-sheet assemblies



● Watertight HX closed-end Tubtara® with o-ring seal (mechanical)

- Large flanged head with a cylindrical groove and O-ring seal mounted underneath
- O-ring seal slides into the groove and is - independent from setting force - compressed between head and plate during installation
- Metal-to-metal contact after setting, therefore assuring spin out resistance
- HX concept guarantees a seal away from possible burrs or sharp hole edges
- Seal fully protected against UV-light influences
- Excellent protection against ingress of fluids, moisture, oil or dirt even under high pressures up to at least 10 bar ¹
- Different seal material like Viton, EPDM or Silicone possible
- IP 68 guaranteed under Dejong test conditions

● Watertight (H)DPX Tubtara® with applied sealant under head (chemical)

- Non-reactive peripheral seal, made of flexible organic based material, applied under the head
- Seal material is gap filling, forming a robust seal between mating surfaces
- Slight variations in seal thickness may influence head height and grip range
- Seal is resistant to many automotive oils, antifreeze and transmission fluids
- Seal can be applied on stocked standard Tubtara parts (all materials and shank types)
- IP 67 guaranteed under Dejong test conditions

Seal type	Seal material	Seal colour	Head type	IP class	Temperature range	Sealing capacity	UV shielded	Shore hardness	Standard / on request
HX	NBR	black	large HX	IP68 ¹	-30°C +120°C	tested till 10 bar IP68 ¹	YES	approx. 70	ST
HX	EPDM	black	large HX	IP68 ¹	-50°C +120°C	tested till 10 bar IP68 ¹	YES	approx. 70	OR
HX	Viton	black	large HX	IP68 ¹	-20° +200°C	tested till 10 bar IP68 ¹	YES	approx. 75	OR
D1	polyurethane resin	blue	P, F ³	IP67 ¹	-40°C - 100°C (150°C peak)	> 150 bar	NO	approx. 50 A	ST
D2	polyurethane acrylate	green	P, F ³	IP67 ¹	-40°C - 100°C	> 150 bar	NO	50 - 65 A	OR
D3	silicone	red	P, F ³	IP67 ²	-50°C +300°C	> 150 bar	NO	43 A	OR
D4	acrylate	light blue	K ³	IP34 - IP67 ²	-60°C +160°C	Low (weak seal)	NO	-	OR
D5	epoxy based	yellow	P, F ³	IP67 ²	-40°C +150°C	> 150 bar	NO	50 D	OR

¹ according to Dejong test conditions

² depending on quality hole and handling, subject to testing

³ P: flat head - F: countersunk head subject to testing - K: low profile head





Stainless Steel 304

Semi-hexagonal shank
Flat head with underhead seal
Closed end

HX

watertight
10 bar (IP68¹)

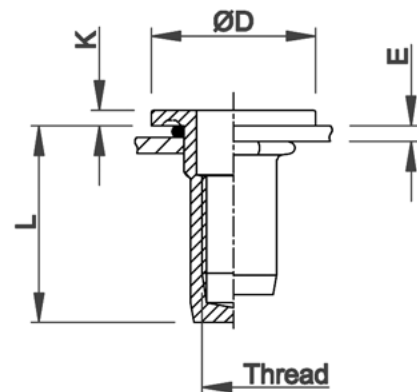
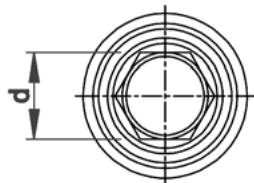
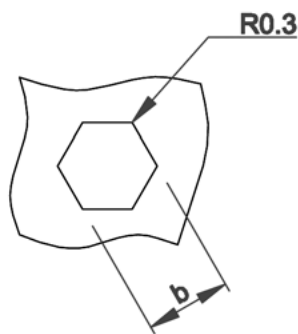

THREAD	TYPE	E = grip	L	b ^{+0,1} = hex hole	d = hex shank	D	K	kg/1000	ORDER CODE	BOX Small	BOX Large
M5	HX3001	0,5-3,0	19,0	7,0	7,0	13,5	1,5	3,8	545 905	(500)	2500
	HX4501	3,0-4,5	20,5	7,0	7,0	13,5	1,5	4,0	545 910	-	-
M6	HX3001	0,5-3,0	21,5	9,0	9,0	16,0	1,5	7,5	546 903	(500)	1250
	HX4501	2,0-4,5	24,4	9,0	9,0	16,0	1,5	8,3	546 907	-	-
M8	HX3001	0,5-3,0	25,0	11,0	11,0	21,0	2,0	13,1	548 902	-	500
	HX5501	3,0-5,5	27,5	11,0	11,0	21,0	2,0	13,6	548 905	-	-

Small box: only for DFS customers, not export - (xxx) handling cost can be charged

Other gripranges, M10 and M12 in progress

All dimensions in mm - Technical data subject to modification

Tolerances and characteristics see chapter 'Technical Information'

¹ IP 68 guaranteed under Dejongd test conditions





Stainless Steel 316

(contains > 2% Molybden)

Semi-hexagonal shank
Flat head with underhead seal
Closed end

HX

watertight
10 bar (IP68¹)

extra high
corrosion resistance

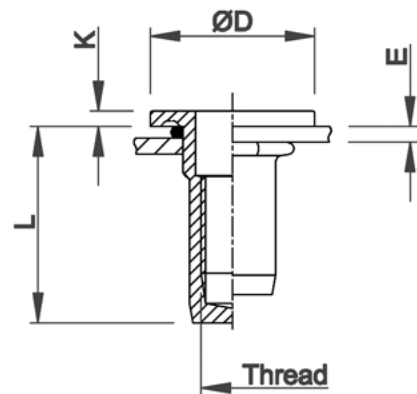
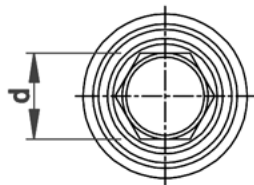
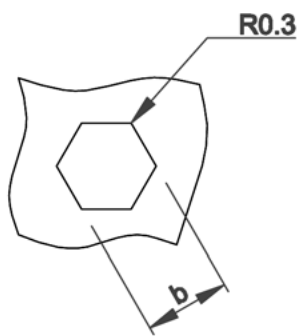

THREAD	TYPE	E = grip	L	b ^{+0,1} = hex hole	d = hex shank	D	K	kg/1000	ORDER CODE	BOX Small	BOX Large
M5	HX3001	0,5-3,0	19,0	7,0	7,0	13,5	1,5	3,8	555 905	(500)	2500
	HX4501	3,0-4,5	20,5					4,0	555 910	-	-
M6	HX3001	0,5-3,0	21,5	9,0	9,0	16,0	1,5	7,5	556 903	(500)	500
	HX4501	2,0-4,5	24,4					8,3	556 906	-	650
M8	HX3001	0,5-3,0	25,0	11,0	11,0	21,0	2,0	13,1	558 902	-	500
	HX5501	3,0-5,5	27,5					13,6	558 905	-	-

Small box: only for DFS customers, not export - (xxx) handling cost can be charged

Other grip ranges, M10 and M12 in progress

All dimensions in mm - Technical data subject to modification
Tolerances and characteristics see chapter 'Technical Information'

¹ IP68 guaranteed under Dejongd test conditions





Steel

Full-hexagonal shank
Flat head with underhead seal
Closed end

Zinktop 480h, Cr^{VI} - free

HX

watertight
10 bar (IP68¹)

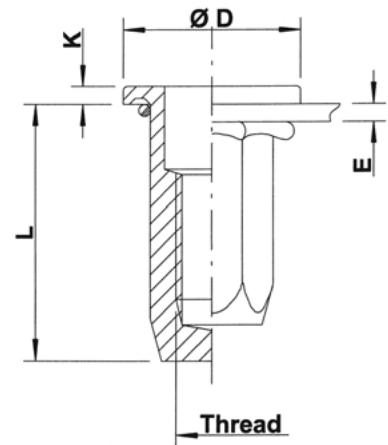
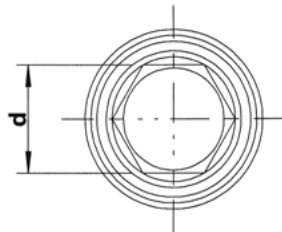
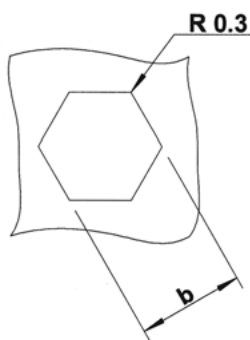

THREAD	TYPE	E = grip	L	b ^{+0,1} = hex hole	d = hex shank	D	K	kg/1000	ORDER CODE	BOX Small	BOX Large
M5	HX3001	0,5-3,0	19,0	7,0	7,0	13,0	1,5	4,3	525 925	(1000)	2500
M6	HX3001	0,5-3,0	21,5	9,0	9,0	15,0	1,5	8,0	526 942	(1000)	1250
	HX5501	3,0-5,5	24,0					8,3	526 949*	-	1250
M8	HX3001	0,5-3,0	26,7	11,0	11,0	20,0	2,0	14,8	528 935	-	500
	HX6001	3,0-6,0	29,7					15,4	528 943	-	500
	HX8001	6,0-8,0	31,7					16,0	528 958	-	-

Small box: only for DFS customers, not export - (xxx) handling cost can be charged

* **Non-stock item:** minimum order quantity required after depletion of stock

Other gripranges, M10 and M12 in progress

All dimensions in mm - Technical data subject to modification
Tolerances and characteristics see chapter 'Technical Information'

¹ IP 68 guaranteed under Depond test conditions





Stainless Steel 304

Round shank
Flat head with underhead seal
Closed end

DPX

watertight IP67¹

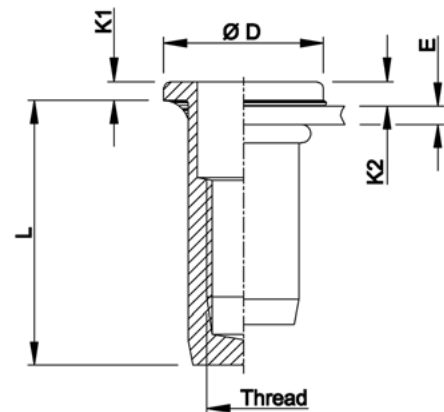
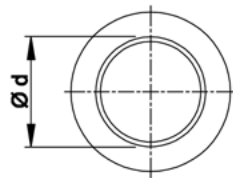
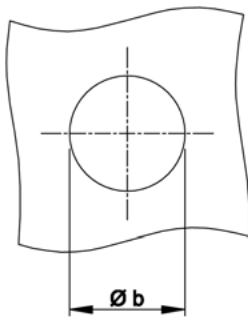

THREAD	TYPE	E = grip	L	b ^{+0,1} = drill dia	d = shank dia	D	K1	K2	kg/1000	ORDER CODE	BOX Small	BOX Large
M4	DPX15	0,5-1,5	15,0	6,0	6,0	9,0	1,0	1,3	2,3	544 1105	(1000)	5000
M5	DPX25	0,5-2,5	17,5	7,0	7,0	10,0	1,0	1,3	3,1	545 1805	(500)	2500
	DPX45	2,5-4,5	19,5									
M6	DPX25	0,5-2,5	21,5	9,0	9,0	12,0	1,5	1,9	6,7	546 1005	(500)	1500
	DPX45	2,5-4,5	23,5									
M8	DPX25	0,5-2,5	23,5	11,0	11,0	15,0	1,5	2,0	10,0	548 0655	(500)	1000
	DPX50	2,5-5,0	26,0									

Small box: only for DFS customers, not export - (xxx) handling cost can be charged

Delivery time: minimum 3 weeks based on stock availability of standard Tubtara®

Other gripranges, M10 and M12 on demand

All dimensions in mm - Technical data subject to modification

Tolerances and characteristics see chapter "Technical Information"

¹ IP 67 guaranteed under Dejongd test conditions

K2: Reference values only. Several factors (seal thickness, hole size, setting force ...) influence head and seal thickness after installation.





Stainless Steel 304

Semi-hexagonal shank
Flat head with underhead seal
Closed end

HDPX

watertight IP67¹

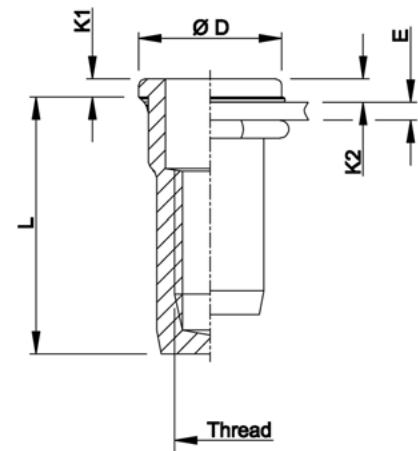
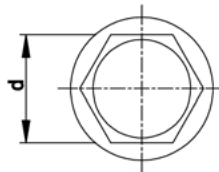
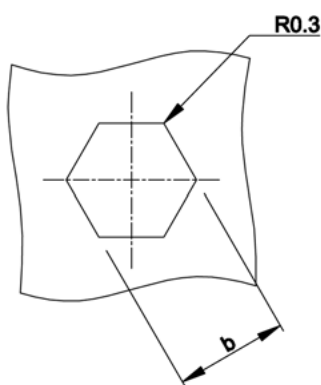

THREAD	TYPE	E = grip	L	b ^{+0,1} = hex hole	d = hex shank	D	K1	K2	kg/1000	ORDER CODE	BOX Small	BOX Large
M4	HDPX15	0,5-1,5	15,0	6,0	6,0	9,0	1,0	1,3	2,3	544 5205	(1000)	5000
M5	HDPX20	0,5-2,0	17,5	7,0	7,0	10,0	1,0	1,3	3,1	545 5205	(500)	2500
M6	HDPX20	0,5-2,0	21,5	9,0	9,0	12,0	1,5	1,9	6,7	546 4705	(500)	1500
	HDPX40	2,0-4,0	23,5									
M8	HDPX20	0,5-2,0	23,5	11,0	11,0	15,0	1,5	2,0	9,8	548 2605	(500)	750
	HDPX45	2,0-4,5	26,0									

Small box: only for DFS customers, not export - (xxx) handling cost can be charged

Delivery time: minimum 3 weeks based on stock availability of standard Tubtara®
Other grip ranges, M10 and M12 on demand

All dimensions in mm - Technical data subject to modification
Tolerances and characteristics see chapter "Technical Information"

¹ IP 67 guaranteed under Dejong test conditions

K2: Reference values only. Several factors (seal thickness, hole size, setting force ...) influence head and seal thickness after installation.





Stainless Steel 316

(contains > 2% Molybden)

Round shank
Flat head with underhead seal
Closed end

DPX

watertight IP67¹

extra high
corrosion resistance

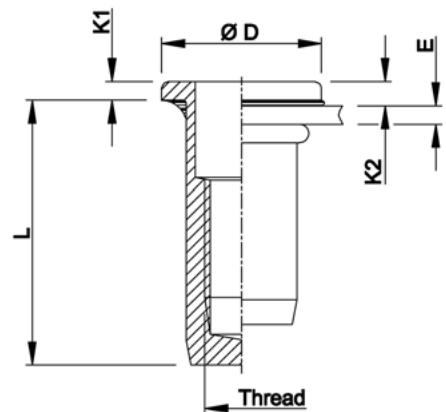
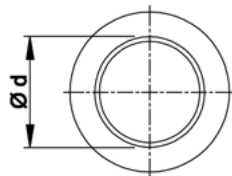
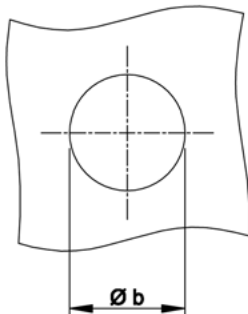

THREAD	TYPE	E = grip	L	b ^{+0,1} = drill dia	d = shank dia	D	K1	K2	kg/1000	ORDER CODE	BOX Small	BOX Large
M4	DPX15	0,5-1,5	15,0	6,0	6,0	9,0	1,0	1,3	2,3	554 1105	(500)	1500
M5	DPX25	0,5-2,5	17,5	7,0	7,0	10,0	1,0	1,3	3,1	555 1805	(500)	1500
	DPX45	2,5-4,5	19,5									
M6	DPX25	0,5-2,5	21,5	9,0	9,0	12,0	1,5	1,9	6,7	556 1005	(500)	750
M8	DPX25	0,5-2,5	23,5	11,0	11,0	15,0	1,5	2,0	10,0	558 0655	(500)	1000

Small box: only for DFS customers, not export - (xxx) handling cost can be charged

Delivery time: minimum 3 weeks based on stock availability of standard **Tubtara**®
Other grip ranges and dimensions on demand

All dimensions in mm - Technical data subject to modification
Tolerances and characteristics see chapter "Technical information"

¹ IP 67 guaranteed under Dejongd test conditions

K2: Reference values only. Several factors (seal thickness, hole size, setting force ...) influence head and seal thickness after installation.





Stainless Steel 316

(contains > 2% Molybden)

Semi-hexagonal shank
Flat head with underhead seal
Closed end

HDPX

watertight IP67¹

extra high
corrosion resistance

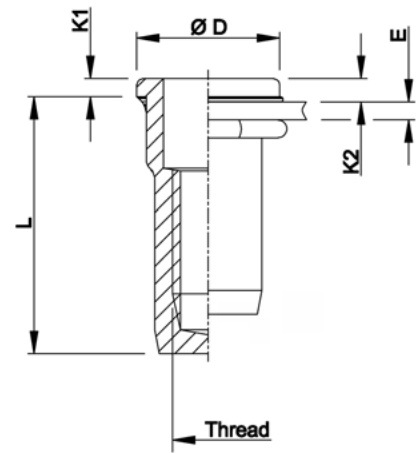
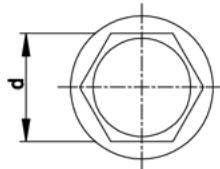
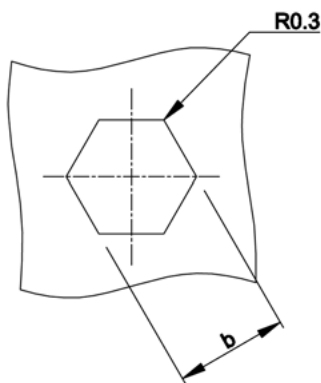

THREAD	TYPE	E = grip	L	b ^{+0,1} = hex hole	d = hex shank	D	K1	K2	kg/1000	ORDER CODE	BOX Small	BOX Large
M4	HDPX15	0,5-1,5	15,0	6,0	6,0	9,0	1,0	1,3	2,3	554 5205	(500)	2000
M5	HDPX20	0,5-2,0	17,5	7,0	7,0	10,0	1,0	1,3	3,1	555 5205	(500)	1500
M6	HDPX20	0,5-2,0	21,5	9,0	9,0	12,0	1,5	1,9	6,7	556 4705	(500)	750
	HDPX40	2,0-4,0	23,5									
M8	HDPX20	0,5-2,0	23,5	11,0	11,0	15,0	1,5	2,0	9,8	558 2605	-	500
	HDPX45	2,0-4,5	26,0									

Small box: only for DFS customers, not export - (xxx) handling cost can be charged

Delivery time: minimum 3 weeks based on stock availability of standard Tubtara®
Other gripranges and dimensions on demand

All dimensions in mm - Technical data subject to modification
Tolerances and characteristics see chapter "Technical Information"

¹ IP 67 guaranteed under Dejongd test conditions

K2: Reference values only. Several factors (seal thickness, hole size, setting force ...) influence head and seal thickness after installation.



Application-oriented solutions:

Customised features



Different materials and coatings



Specific anti-rotation head



Special thread requirements

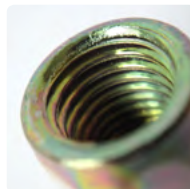

Setting in engineered plastics



- In-house R&D and technical support for specific applications



Dejond has more than 60 years of experience in developing and manufacturing **Tubtara**® blind rivet nuts. **Tubtara**® has become synonymous with high quality performance, innovation, in-house R&D and technical support. Always one step ahead of industry demand.

Tubtara® blind rivet nuts can be tailor-made in accordance with your specifications and to suit the demands of almost every application. Our in-house R&D engineers always strive to manufacture the best possible blind rivet nut fit. These customised solutions offer additional features to the standard **Tubtara**® such as increased torque-to-turn, sealing, controlled deformation, integration into parent material, centering, pressure spread, compatibility with other fasteners or tools, special thread requirements etc. The Tubtara's designed for the latest aerospace programmes for instance are used in composite material and aluminium structures on wing parts and seats.

Besides blind rivet nuts, Dejond also concentrates on cold forming selected parts according to customers' drawings for very specific applications.

For a detailed summary, visit www.tubtara.com and click on 'customised solutions'.



Our brochure on customised solutions
available in different languages



Please take the following into consideration when ordering custom-made rivet nuts:

- Give us an accurate description of the application.
- If possible, include a drawing with indication of sizes, tolerances, material type and exact sheet thickness (incl. tolerances).
- Tell us about other special features or important remarks we need to know.
- If possible, provide us with a sample of the application and/or existing fastener solution.
- Indicate any special technical requirements such as torque value, mount load, tensile or thread strength, etc..
- Specify which type of setting equipment will be used.

Our R&D people will evaluate your request and our Sales Department will provide you with information.

Some examples of additional features providing innovative solutions for your problems:

- Increased torque-to-turn / spin-out resistance
- Spacer function
- Controlled deformation
- (Full) integration into parent material (e.g. composites)
- Flush installation
- Seal function
- Visual identification
- Centering
- Search function (for automatic installation)
- Pressure spread
- Facilitate field repair (increased torque-to-turn resistance)
- Compatibility with available fasteners
- Compatibility with available tools
- Drip / dry function (paint, oil, ...)
- Blind installation / limited space
- Special thread requirements
- (Electrical) conductivity
- Increased push-out force
- Increased pull-out force (thread strength)
- Anti-vibration
- Customised grip (range)

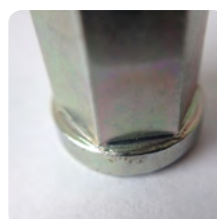
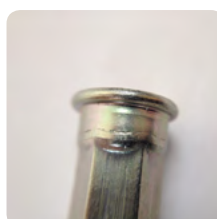
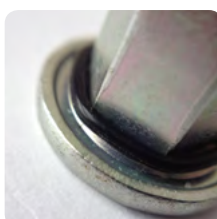
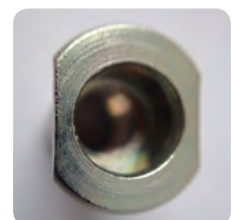
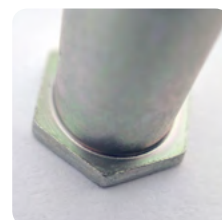
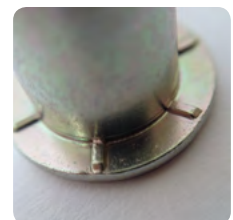
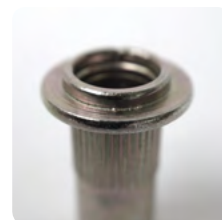



Stainless Steel A5 & A6

Standard shank versions
Standard head types
Open or closed end
1st and 2nd grips

superior corrosion
protection

Cold formed Tubtara® in high alloy austenitic stainless steel A5 and A6



● Material

Stainless steel A5 : 316 Ti – WNr 1.4571
Stainless steel A6 : 904L – WNr 1.4539

● Applications

- extremely demanding, chloride bearing applications where even A4 fasteners in stainless 316 offer insufficient corrosion protection
- A6 grade is also armoured against strong acid bearing environments
- civil engineering, tunnel infrastructures, ceiling panels in swimming pools etc.

● Important advantages

- Superior corrosion protection, mainly thanks to considerable nickel and molybdenum content
- A6 guarantees increased protection against pitting and crevice corrosion, reaching a PRE (pitting resistance equivalent) value of 35 (compared to PRE 25 for stainless 316)

● Samples

Following samples available from stock: stainless A6 M6 UPO 30 – stainless A5 M8 UPO30 / M8 UPO 65 / M8 UFO 45 / M8 UFO 65 / M8 UFX 45 / M8 UKO 30 / M8 HUKO 30

Development of other dimensions upon request





Seal Inox® topcoat on stainless steel

Semi-hexagonal or knurled shank
Standard head types
Open or closed end
Different grips

Seal Inox® topcoat on stainless Tubtara® prevents galling

● What is Seal Inox®?

Seal Inox® is a topcoat that makes it easier to assemble stainless steel threaded parts. The integrated lubricant additive in this topcoat prevents gripping during assembly, also called 'galling'.

Galling is caused by adhesion of two sliding surfaces under increased friction and often occurs between stainless steel threaded connections.

Characteristics :

- thin dry layer
- can be applied in single or two layers [to avoid any assembly problem, we recommend to use a (hex) hole tolerance of 0.05 - 0.15 mm instead of 0 - 0.1 mm]
- visually distinguishable grey treatment, other colours on request
- friction coefficient 0.09 – 0.14 (according to DIN EN ISO 16047)
- temperature resistance 180°C
- conforms to ELV and RoHS, Cr⁶⁺ free

● Benefits of a Seal Inox® topcoat on stainless Tubtara® blind rivet nuts

- reduces friction and prevents galling
- provides a higher clamping force
- reduces assembly time
- slows down contact corrosion
- protects against various chemicals e.g. chlorides, acids and oils
- can be applied on our different stainless steel qualities: 304, 316, 316Ti, 904L
- is preferentially applied on hexagonal or knurled Tubtara's since Seal Inox® will be present on both inside and outside surfaces, thus potentially reducing torque-to-turn for round Tubtara's

Galling between a stainless bolt or screw and a stainless Tubtara® can occur when the assembly is done with a power tool (often at high speeds), but also when the bolt or screw is assembled and tightened by hand.

● Availability

Seal Inox® is only applied to order (non-standard).
Prices and lead times available on request.





Stainless Steel 304

Round shank
Anti-turn head
Open end

ATO

easy repair solution:
extra high
torque-to-turn values

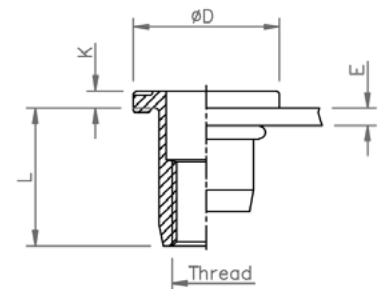
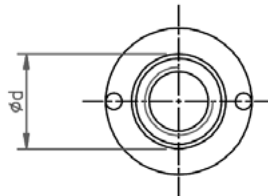
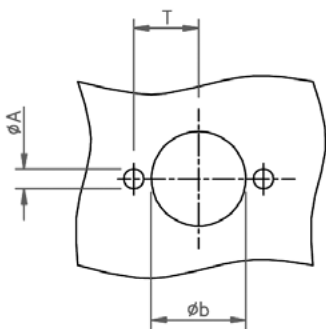

THREAD	TYPE	E = grip	L	b ^{+0,1} = drill dia	d = shank dia	D	K	A	T	kg/ 1000	ORDER CODE	BOX Small	BOX Large
M6	ATO30	0,5-3,0	14,5	9,0	9,0	14,0	1,5	1,8	6,25	-	-	-	-
M8	ATO30	0,5-3,0	16,0	11,0	11,0	17,0	2,0	2,3	7,50	7,4	548 1010*	-	1200
	ATO55	3,0-5,5	18,5								548 1020*	-	1000
M10	ATO35	0,8-3,5	21,0	13,0	13,0	19,0	2,0	3,0	8,75	11,3	540 1600*	-	750

Tool to position Ø A:

M6	AT 206*
M8	AT 208*
M10	AT 210*



Small box: only for DFS customers, not export - (xxx) handling cost can be charged

Samples available from stock

* **Non-stock item:** minimum order quantity required after depletion of stock

All dimensions in mm - Technical data subject to modification
Tolerances and characteristics see chapter 'Technical Information'





Steel

Round shank
Anti-turn head
Open end

Zinktop 480h, Cr^{VI} - free
ATO

easy repair solution:
extra high
torque-to-turn values

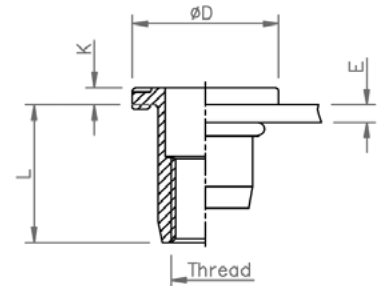
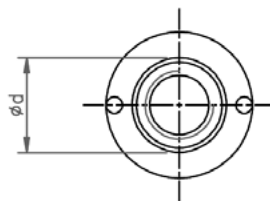
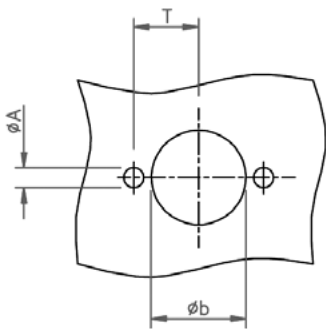

THREAD	TYPE	E = grip	L	b ^{+0,1} = drill dia	d = shank dia	D	K	A	T	kg/1000	ORDER CODE	BOX Small	BOX Large
M6	ATO30	0,5-3,0	14,5	9,0	9,0	14,0	1,5	1,8	6,25	4,6	526 1029*	-	1750
M8	ATO30	0,5-3,0	16,0	11,0	11,0	17,0	2,0	2,3	7,5	7,4	528 1022*	-	1200
M10	ATO35	0,8-3,5	21,0	13,0	13,0	19,0	2,0	3,0	8,75	11,4	520 1609*	-	750

Tool to position Ø A:

M6	AT 206*
M8	AT 208*
M10	AT 210*



Small box: only for DFS customers, not export - (xxx) handling cost can be charged

Samples available from stock

* **Non-stock item:** minimum order quantity required after depletion of stock

All dimensions in mm - Technical data subject to modification
Tolerances and characteristics see chapter 'Technical Information'





Stainless Steel 304

Round shank
Low profile head
Open end

UKO
UNIFIED THREAD

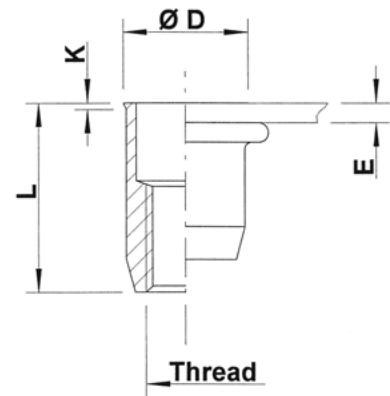
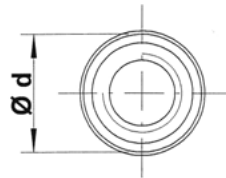
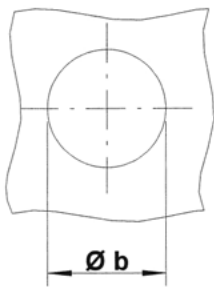

THREAD	TYPE	E = grip	L	b ^{+0,1} = drill dia	d = shank dia	D	K	kg/1000	ORDER CODE	BOX Large
10-32 UNF	UKO30	0,5-3,0	12,0	7,0	7,0	7,5	0,5	1,5	549 500	5000
1/4-20 UNC	UKO30	0,5-3,0	14,5	9,0	9,0	9,5	0,5	3,4	547 660	3000
5/16-18 UNC	UKO30	0,5-3,0	16,0	11,0	11,0	11,5	0,5	5,0	547 830	2000

All dimensions in mm

THREAD	TYPE	E = grip	L	b ^{+0.004} = drill dia	d = shank dia	D	K	lbs/1000	ORDER CODE	BOX Large
10-32 UNF	UKO30	.020-.118	0.472	0.276	0.276	0.295	.020	3.30	549 500	5000
1/4-20 UNC	UKO30	.020-.118	0.571	0.354	0.354	0.374	.020	7.49	547 660	3000
5/16-18 UNC	UKO30	.020-.118	0.630	0.433	0.433	0.453	.020	11.00	547 830	2000

All dimensions in inches - Technical data subject to modification
Tolerances and characteristics see chapter 'Technical Information'





Stainless Steel 304

Semi-hexagonal shank
Low profile head
Open end

**HUKO
UNIFIED THREAD**

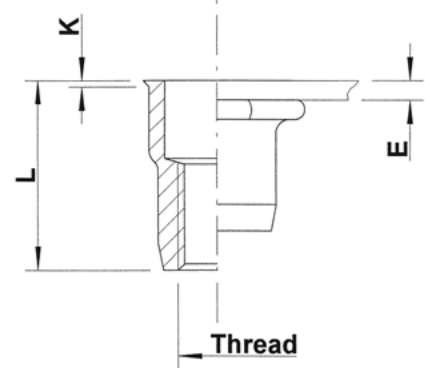
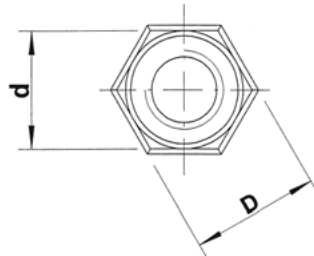
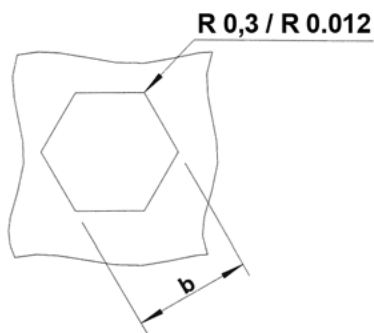

THREAD	TYPE	E = grip	L	b ^{+0,1} = hex hole	d = hex shank	D = hex head	K	kg/1000	ORDER CODE	BOX Large
10-32 UNF	HUKO30	0,5-3,0	12,0	7,0	7,0	7,5	0,5	1,5	549 530	5000
1/4-20 UNC	HUKO30	0,5-3,0	14,5	9,0	9,0	9,7	0,5	3,3	547 690	3000
5/16-18 UNC	HUKO30	0,5-3,0	16,0	11,0	11,0	11,8	0,5	4,9	547 850	2000

All dimensions in mm

THREAD	TYPE	E = grip	L	b ^{+0,004} = hex hole	d = hex shank	D = hex head	K	lbs/1000	ORDER CODE	BOX Large
10-32 UNF	HUKO30	.020-.118	0.472	0.276	0.276	0.295	.020	3.30	549 530	5000
1/4-20 UNC	HUKO30	.020-.118	0.571	0.354	0.354	0.382	.020	7.27	547 690	3000
5/16-18 UNC	HUKO30	.020-.118	0.630	0.433	0.433	0.465	.020	10.79	547 850	2000

All dimensions in inches - Technical data subject to modification
Tolerances and characteristics see chapter 'Technical Information'



Setting equipment & tooling

A **Tubtara**® can be set with a hand-, (oleo-)pneumatic or battery tool, a press or an automatic installation unit.

- Hand tool

DFS 309 T								
	Tubtara® blind rivet nuts							
	M3	M4	M5	M6	M8	M10	M12	M14
Steel		•	•	•	•	•		
Stainless steel		•	•	•	•	•		
Aluminium		•	•	•	•	•	•	
	blind rivet bolts							
	M3	M4	M5	M6	M8	M10	M12	M14
Steel			•	•	•			
Stainless steel			•	•	•			
Aluminium			•	•	•			

Heavy duty hand tool for field and low volume production use
Push and pull mechanism

Tooling is included except for M12

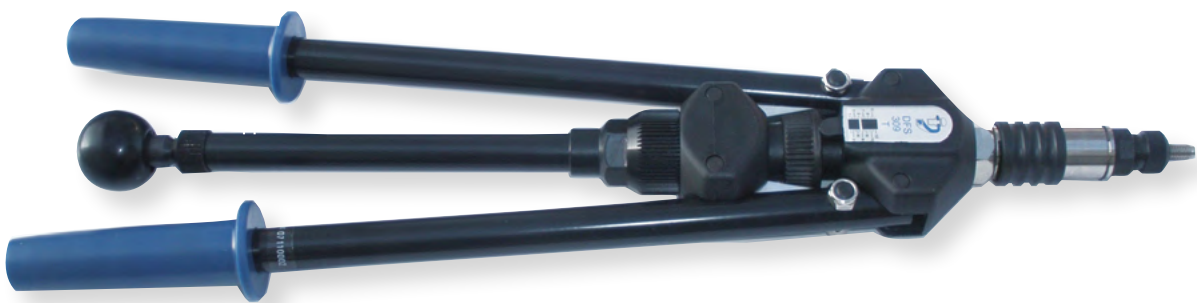



DFS 307 T								
	Tubtara® blind rivet nuts							
	M3	M4	M5	M6	M8	M10	M12	M14
Steel	•	•	•					
Stainless steel	•	•	•					
Aluminium	•	•	•	•				

Compact & practical hand tool for light duty assembly.

DFS 311 T								
	Tubtara® blind rivet nuts							
	M3	M4	M5	M6	M8	M10	M12	M14
Steel				•	•	•	•	
Stainless steel				•	•	•		
Aluminium				•	•	•	•	



Strong and reliable hand tool for heavy duty assembly in the field.



NM 1								
	Tubtara® blind rivet nuts							
	M3	M4	M5	M6	M8	M10	M12	M14
Steel		•	•	•	•	•	•	
Stainless steel		•	•	•				
Aluminium		•	•	•	•	•	•	

Small hand tool for prototype work and repairs

Setting method

Select one of the **Tubtara**® blind rivet nuts out of our production and a setting tool adequate for the application. Take a test workpiece and drill an appropriate hole

STEP 1

Screw the **Tubtara**® blind rivet nut (A) on the mandrel (B) of the setting tool. In the case of the open version, the mandrel should protrude about 1 mm. For closed rivet nuts, continue screwing until you feel resistance. Screw the anvil (C) against the head of the **Tubtara**® and block it with the locking nut (D).

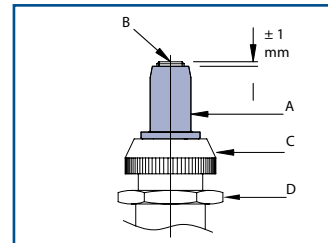

STEP 2

Insert the **Tubtara**® blind rivet nut, mounted on the setting tool, into the hole of the workpiece

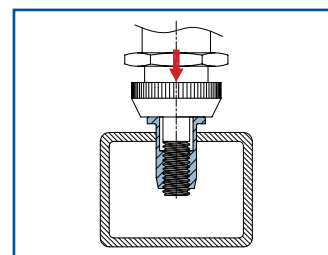

STEP 3

Set the **Tubtara**®. The Tubtara's deformation chamber now forms the counter head (bulb) on the underside of the workpiece

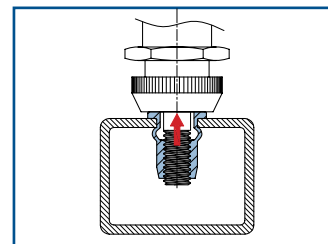

STEP 4

Unscrew the mandrel from the **Tubtara**®.

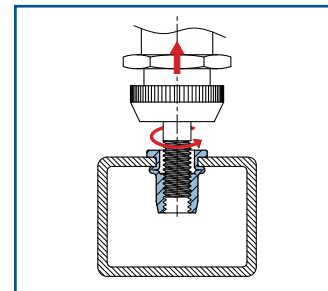

STEP 5

The **Tubtara**® blind rivet nut is now set. You can now easily insert your bolt or screw to assemble another component.

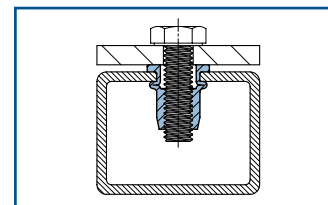

● Countersunk heads

Are you using a **Tubtara**® blind rivet nut with a countersunk head? Always countersink at 90° so that the head of the installed **Tubtara**® protrudes about 0.1 mm above your workpiece. This ensures direct contact with the assembled component.

Don't have the possibility to countersink?
Use a low profile head

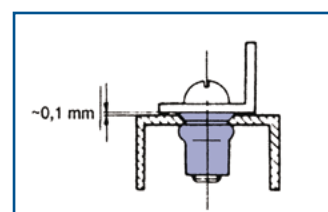

Materials

The **Tubtara**® is available from stock in steel, aluminium and stainless steel 304 & 316.

For critical bearing environments, we can also offer the following solutions to cope with most environmental conditions :

- superior cold formed stainless A5 or A6 quality on demand,
- several finishing options on stainless like Cadmium, ZnNi, Seal Inox®,
- passivated stainless steel.

Available from stock:

Material			W Nr
Aluminium	AlMg2,5	5052	3.3523
Steel	C8C	QST 34-3	1.0213
Stainless steel A2	304Cu		1.4567
Stainless steel A4	316Cu		1.4578

Available on request :

Material		W Nr
Stainless steel A5	316Ti	1.4571
Stainless steel A6	904L	1.4539

Material specifications are always subject to modifications.

● How to choose the right material ?

Choosing the right material and coating for your **Tubtara**® blind rivet nuts is very important for obtaining optimal functionality during the whole life cycle, especially when environmental conditions are unknown or critical. Influences can be chemical (elements dissolved in water), abrasive (sand), heat, friction, contact with other metals, corrosive environments, etc.

The ideal material choice is not always easy and all conditions should be taken into account. We therefore strongly advise to check the following tables and do some tests in the specific application environment in advance.



● Requirements & solutions

	Aluminium	Steel with appropriate coating	Stainless A2	Stainless A4	Stainless A5	Stainless A6
colour distinction		xxx				
visual identification		xxx				
weight-saving	xxx		x	x	x	x
durable	x	x → xxx	xx	xxx	xxx	xxx
easily recycable	xxx	xxx	xxx	xxx	xxx	xxx
electrical conductivity	xxx	xx	xx	xx	xx	xx
high/low temperature properties	x	xx	xx	xxx	xxx	xxx
non-magnetic	xxx		x	x	x	x
increased corrosion resistance	xx	o	xxx	xxx	xxx	xxx
resistant to atmospheric exposure	xx	o	xxx	xxx	xxx	xxx
resistant to chloride atmospheres		o		xxx	xxx	xxx
resistant to polluted environments		o		xxx	xxx	xxx
resistant to harsh environments		o			xxx	xxx
resistant to process fluids		o			xxx	xxx
top coating possible		xxx				
passivation possible			x	x	x	x

Legend	
o	possible influence
x	small influence
xx	larger influence
xxx	largest influence

● Galvanic couples

A suited material choice is not always easy and all conditions should be taken into account. The table below shows some connection guidelines for corrosion:

		Blind rivet nut material		
		zinc plated steel	aluminium	stainless steel 304 & 316
base metal wherein Tubtara is set	aluminium			
	zinc plated steel			
	brass, copper	T T®	T T®	
	stainless steel 4xx	T T®	T T®	
	stainless steel 304 & 316	T T®	T T®	

Legend	
	base metal and Tubtara ® ok
	base metal corrodes where in contact with Tubtara ®
T T®	base metal ok but Tubtara ® will corrode
	corrosion base metal heavily increased by Tubtara ®

We strongly advise to do some tests in the specific application environment. Samples are available on request.

Coatings

A suitable coating choice can offer additional characteristics to your **Tubtara®**.

- Coating on steel available from stock

Zinktop

High-quality Cr⁶⁺ & Ni free plating
 Conforms with ROHS 2, Reach, ELV directives
 96 h white rust - 480 h red rust
 10µ ±2µ

- Survey available coating offer



photo	coating description	standard / on request	salt spray test (h) ISO 9227		colour / aspect	corrosion protection	RoHS / Reach compliant	remarks
			white rust	red rust				
1	Zinc blue/white Cr ³⁺	REQ	24	72	blue/white	*	☑	Cr ⁶⁺ free
2	Zinc black Cr ³⁺	REQ	48	96	black	*	☑	Cr ⁶⁺ free
3	Zinc yellow Cr ³⁺	REQ	96	240	light yellow	**	☑	Cr ⁶⁺ free
4	Zinktop	ST	96	480	light grey	****	☑	Cr ⁶⁺ and Ni free
5	Zinktop Cobalt free	REQ	96	480	light grey	****	☑	Cr ⁶⁺ , Ni and Co free
6	Ultra 1000	REQ	240	1000	light grey	*****	☑	Cr ⁶⁺ and Ni free
7	ZnNi (Zinc Nickel)	REQ	quality according to customer's specs					
8	Vibraseal®	REQ	x	x	red, green			seals + anti-vibration
9	Gleitmo®	REQ	x	x	-			friction reduction
10	Seal Inox®	REQ	x	x	matt grey	*****		avoids galling
11	Passivation	REQ				*****		only on stainless steel

The Ultra 1000 is more than doubling the resistance to red rust in the salt spray test compared to the standard Zinktop. The offer of blue and black trivalent coatings, as well as the Cobalt free Zinktop, are developed to tackle imminent Reach regulations and can be delivered on demand.

* Zinc yellow Cr⁶⁺ plating is no longer standard and has been omitted from this catalogue. Due to REACH phase out, production of steel yellow hexavalent chromated parts has discontinued completely. For availability, only until depletion of stock, please contact our customer service.

● **Stainless Steel**

All stainless steel Tubtara's have been treated by a special process to obtain a natural passivation layer, improving the corrosion resistance compared to common stainless steel parts in the market.

Optional coatings on stainless steel are

- Gleitmo® / Seal Inox®
- full passivation.

● **Why use a coating ?**

Requirements & solutions :

	Zinktop on steel	Coloured plating on steel	Passivation on stainless steel	Gleitmo®	Vibraseal®	Seal Inox®	Molykote®
appropriate visual aspects		+					
colour distinction		+			o	o	
to avoid galling				+		+	+
reduction of friction				+		+	+
increase of friction				-		-	-
to avoid galvanic couple	o	o	+		+	+	
electrical conductivity	+				-	-	-
anti-vibration function					+		
increased corrosion resistance	+		+			+	
seal function					+	+	
UV illumination				+			

Legend	
-	negative influence
o	possible influence
+	positive influence

We strongly advise to do some tests in the specific application environment. Samples are available on request.



Technical Data

● General tolerances

	Head form	Dimensions in mm	Dimensions in inches
D (head diameter)	Flat head Countersunk head Low profile head	$\pm 0,35$ 0 -0,5 -0,15 +0,3	$\pm.014$ 0 -.020 -.006 +.012
K (head thickness)	Flat head Countersunk head Low profile head	$\pm 0,15$ 0 +0,3 -0,05 +0,3	$\pm.006$ 0 +.012 -.002 +.012
L (length)	General Stainless M10 shank 13 mm	$\pm 0,35$ $\pm 0,5$	$\pm.014$ $\pm.020$
Metric thread= 6H			
Shank size	General (incl. KN) Splined shank (RS) M10 shank 12,4 mm	-0,02 -0,15 $\pm 0,08$ $\pm 0,08$	-.001 -.006 $\pm.003$ $\pm.003$

Example:

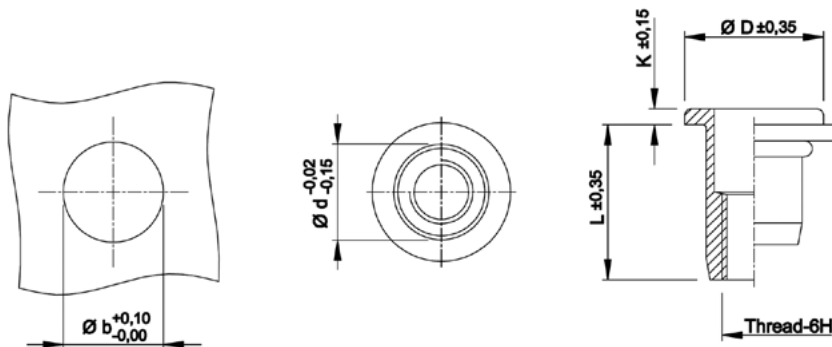

● Recommended tightening torque values (Nm)

Max. recommended torque to avoid damaging the threaded connection and ensure optimal screw-nut assembly:

	M3	M4	M5	M6	M8	M10	M12
Aluminium	2,0	2,2	4,5	9,5	17,0	30,0	
Steel	2,5	3,0	5,9	11,0	25,0	49,0	80,0
Stainless Steel	2,5	3,0	5,9	11,0	25,0	49,0	80,0

Recommendations for 8.8 bolts in steel and class A2-70 bolts in stainless steel.

● Mechanical properties

The tables below show some indicative standard values for Tubtara's with round or hexagonal shank and flat head in first grip for middle sheet thickness within range.

Mechanical reference values

product	material	pull-out	max. torque	torque-to-turn	shear test
		kN	Nm	Nm	kN
Round shank					
M3 UPO 20	Steel C8C	> 5,8	> 2,0	1,8	1,9
	Alu 5052	> 3,1	1,9	0,8	0,6
	SS 304Cu	-	-	-	-
M4 UPO 30	Steel C8C	> 10,8	> 7,5	2,7	2,6
M4 UPO 30	Alu 5052	> 4,5	4,9	1,4	1,1
M4 UPO 20	SS 304Cu	> 11,0	7,1	2,6	3,5
M5 UPO 30	Steel C8C	> 12,0	> 10,0	4,7	3,5
	Alu 5052	> 5,2	4,9	1,5	1,6
	SS 304Cu	> 14,5	> 16,0	3,0	4,8
M6 UPO 30	Steel C8C	> 21,0	> 19,0	7,0	5,0
	Alu 5052	> 10,5	16,0	3,2	2,4
	SS 304Cu	> 27,0	> 22,0	6,8	7,3
M8 UPO 30	Steel C8C	> 33,0	> 50,0	13,0	6,0
	Alu 5052	> 15,0	33,0	5,3	2,9
	SS 304Cu	> 40,0	> 70,0	9,0	9,0
M10 UPO 35	Steel C8C	> 40,0	> 70,0	15,0	8,0
	Alu 5052	> 20,0	39,5	7,0	3,7
	SS 304Cu	> 43,0	> 70,0	8,0	8,5
M10 SPO 35	Steel C8C	> 40,0	> 70,0	15,0	8,0
	Alu 5052	-	-	-	-
	SS 304Cu	> 43,0	> 70,0	13,0	8,4
M12 UPO 40	Steel C8C	> 63,0	> 120,0	32,0	11,5
	Alu 5052	-	-	-	-
	SS 304Cu	> 70,0	> 130,0	25,0	14,0
Hexagonal shank					
M4 HUPO 20	Steel C8C	> 8,8	> 7,5	> 5,5	2,6
	SS 304Cu	> 10,8	> 7,1	6,0	3,7
M5 HUPO 30	Steel C8C	> 12,0	12,0	> 6,5	3,6
	SS 304Cu	> 15,5	15,0	> 9,0	4,8
M6 HUPO 30	Steel C8C	23,0	> 24,5	> 21,0	5,1
	SS 304Cu	24,5	> 23,0	> 22,0	7,2

product	material	pull-out	max. torque	torque-to-turn	shear test
		kN	Nm	Nm	kN
M8 HUPO 30	Steel C8C	32,8	> 50,0	> 30,0	6,6
	SS 304Cu	39,0	> 64,0	32,0	9,4
M10 HSPO 35	Steel C8C	> 40,0	> 70,0	50,0	7,9
	SS 304Cu	> 43,0	> 70,0	> 50,0	10,2
M12 HUPO 40	Steel C8C	> 63,0	> 120,0	68,0	12,5
	SS 304Cu	> 70,0-	> 130,0	> 70,0	14,6

- Bolts class 8.8 were used
- > : value will be higher, but test could not be completed due to breakage of bolt or min. value is used as reference
- Steel plate (HRB 55) was used to set the **Tubtara®** (approximately middle of grip range)
- Shear test in most cases the **Tubtara** is pulled out of the sheet without shearing.

Geometrical reference values (open end parts)

product	material	setting force	stroke	size bulb forming	length under plate
		kN	mm	mm	mm
Round shank					
M3 UPO 20	Steel C8C	4,0	2,6	6,6 to 6,7	5,9 to 6,1
	Alu 5052	2,3	1,9	6,0 to 6,1	6,4 to 6,6
	SS 304Cu	-	-	-	-
M4 UPO 30	Steel C8C	4,5	2,8	7,8 to 7,9	6,7 to 6,8
M4 UPO 30	Alu 5052	2,2	2,7	7,7 to 7,8	6,8 to 7,0
M4 UPO 20	SS 304Cu	6,0	2,4	7,3 to 7,4	7,6 to 7,8
M5 UPO 30	Steel C8C	6,5	3,8	9,4 to 9,5	7,3 to 7,4
	Alu 5052	3,4	3,6	9,3 to 9,4	7,3 to 7,4
	SS 304Cu	8,0	3,5	8,9 to 9,2	7,3 to 7,5
M6 UPO 30	Steel C8C	9,5	4,0	11,6 to 11,8	9,3 to 9,6
	Alu 5052	4,9	3,3	11,2 to 11,3	10,0 to 10,2
	SS 304Cu	13,0	4,0	11,3 to 11,6	9,6 to 10,0
M8 UPO 30	Steel C8C	12,0	4,0	13,6 to 13,8	10,9 to 11,2
	Alu 5052	5,5	3,8	13,6 to 13,8	11,1 to 11,3
	SS 304Cu	15,4	4,2	13,6 to 13,7	11,3 to 11,6
M10 UPO 35	Steel C8C	14,5	4,4	15,7 to 15,8	14,4 to 14,5
	Alu 5052	8,0	4,7	15,6 to 15,9	14,1 to 14,4
	SS 304Cu	15,5	4,0	14,8 to 15,0	13,6 to 14,0
M10 SPO 35	Steel C8C	15,5	4,5	16,1 to 16,3	15,5 to 15,7
	Alu 5052	-	-	-	-
	SS 304Cu	23,5	4,6	15,9 to 16,1	16,6 to 16,9

product	material	setting force	stroke	size bulb forming	length under plate
		kN	mm	mm	mm
M12 UPO 40	Steel C8C	20,5	6,5	20,8 to 21,0	17,5 to 18,0
	Alu 5052	-	-	-	-
	SS 304Cu	30,0	7,0	20,5 to 21,5	17,0 to 17,5
Hexagonal shank					
M4 HUPO 20	Steel C8C	5,5	2,8	7,6 to 8,3	6,1 to 6,4
	SS 304Cu	5,3	2,5	7,5 to 7,9	7,5 to 7,9
M5 HUPO 30	Steel C8C	6,1	4,0	9,8 to 10,4	7,8 to 8,2
	SS 304Cu	7,2	3,3	9,1 to 9,5	7,1 to 7,3
M6 HUPO 30	Steel C8C	11,5	3,6	11,4 to 12,5	9,7 to 10,1
	SS 304Cu	10,0	4,3	11,9 to 12,3	9,0 to 9,3
M8 HUPO 30	Steel C8C	14,0	4,6	14,3 to 15,4	10,7 to 11,1
	SS 304Cu	14,0	4,5	14,0 to 14,5	10,7 to 11,1
M10 HSPO 35	Steel C8C	18,0	5,5	17,5 to 18,6	14,4 to 14,7
	SS 304Cu	19,0	6,0	17,0 to 17,6	16,0 to 16,7
M12 HUPO 40	Steel C8C	21,0	6,6	20,7 to 21,6	15,0 to 16,1
	SS 304Cu	25,0	7,0	21,0 to 22,0	17,0 to 17,5

Length under plate of open end parts: values obtained after setting.

To obtain the length under the plate after setting of **closed end parts**, you can add the following sizes to the above-mentioned:

Steel and aluminium (mm)	
M3	3,5
M4	4,5
M5	6,0
M6	7,0
M8	8,0
M10	10,0
M12	10,0

Stainless steel (mm)	
M4	4,5
M5	6,0
M6	7,0
M8	8,0
M10	7,0
M12	10,0

In some cases the real length will be shorter. All dimensions can be checked on the technical data sheets in our catalogue.

In practice, variations may result from differing setting and environmental conditions. The values mentioned can be used as a reference and optimised by using additional features. We strongly advise customers to perform their own tests in the correct material thickness and specific application.

Grip range influences

The following values can be used as a guidance for other versions :

TYPE	Grip	ALUMINIUM			STEEL			STAINLESS STEEL 304 + 316		
		SETTING FORCE	STROKE	PULL-OUT	SETTING FORCE	STROKE	PULL-OUT	SETTING FORCE	STROKE	PULL-OUT
	mm	N	mm	N	N	mm	N	N	mm	N
M3 UPO 20	1,0	2000	2,0	3750	4000	2,5	> 5000			
	2,0	2600	1,5	3280	4750	2,0	> 5000			
M3 UPO 30	2,0	1850	1,5	3900	3700	2,5	> 5000			
	3,0	2050	1,0	3968	4750	2,0	> 5000			
M4 UPO 20	1,0							4900	2,0	> 9000
	2,0							5500	1,5	> 9000
M4 UPO 30	1,0	2100	3,0	5170	4300	2,5	> 8000			
	3,0	2430	1,0	4330	5650	1,5	> 8000			
M4 UPO 35	2,0							5500	2,6	> 9000
	3,5							6000	1,7	> 9000
M4 UPO 45	3,0	2050	2,8	4838	4200	2,5	> 8000			
	4,5	2875	1,5	4421	5000	1,5	> 8000			
M5 UPO 30	1,0	3050	3,5	5500	6150	3,5	12240	7500	3,0	> 15000
	3,0	3650	2,0	5000	7200	2,5	9600	8500	1,7	> 15000
M5 UPO 50	3,0							7500	4,0	> 15000
	5,0							8500	2,0	> 15000
M5 UPO 55	3,0	3000	3,5	6450	5750	4,0	11800			
	5,5	4300	1,5	5525	9650	2,0	10300			
M6 UPO 30	1,0	4500	3,0	11000	9400	4,0	21200	11850	4,0	> 24000
	3,0	5750	2,0	10000	12000	3,0	18500	14460	3,0	> 24000
M6 UPO 50	3,0							13500	4,5	> 24000
	5,0							15000	2,8	> 24000
M6 UPO 55	3,0	4500	3,5	11000	9000	3,5	22700			
	5,5	6100	1,8	10000	11000	2,0	19700			
M6 UPO 80	5,5	4950	4,7	9160	8700	4,0	19900			
	8,0	5400	2,0	8200	11750	2,5	17200			
M8 UPO 30	1,0	5000	3,0	14900	11500	4,0	30400	14500	4,2	> 41000
	3,0	6600	2,0	14000	13750	2,5	26100	18000	2,8	> 41000
M8 UPO 55	3,0	5400	4,0	15500	11500	4,0	32500	14500	5,5	> 41000
	5,5	7400	2,0	11200	15500	2,5	31900	18500	3,0	> 41000

TYPE	Grip	ALUMINIUM			STEEL			STAINLESS STEEL 304 + 316		
		SETTING FORCE	STROKE	PULL-OUT	SETTING FORCE	STROKE	PULL-OUT	SETTING FORCE	STROKE	PULL-OUT
	mm	N	mm	N	N	mm	N	N	mm	N
M8 UPO 80	5,5	5900	4,0	16100	10700	4,0	32400			
	8,0	7850	2,0	13600	14700	2,5	26500			
M10 UPO 30	1,0							14500	3,5	> 45000
	3,0							18500	2,5	> 45000
M10 UPO 35	1,0	6750	4,0	22100	13600	4,5	39600			
	3,5	9000	2,5	17700	17000	2,5	32400			
M10 UPO 50	3,0							14500	3,5	> 39500
	5,0							18500	2,5	> 37000
M10 UPO 60	3,5	9000	5,0	25250	14900	4,0	42300			
	6,0	13000	3,0	23000	17900	2,5	31700			
M10 SPO 35	1,0				13500	4,5	40500	19500	4,5	> 45000
	3,5				16100	2,5	36100	26500	3,5	> 45000
M10 SPO 60	3,5				15900	5,5	48000	21000	5,5	> 45000
	6,0				20400	3,0	37500	25000	3,5	> 45000
M12 UPO 40	1,0				19500	5,5	> 50000	26000	8,0	> 75000
	4,0				25000	4,0	> 50000	34000	5,0	> 70000
M12 UPO 70	4,0				19500	5,5	> 50000	28000	8,0	> 75000
	7,0				25000	4,0	> 50000	37000	5,0	> 70000

Setting Force or Upset Load: Force (in Newton) necessary to deform the **Tubtara®** referred to in an adequate way.

Upset Stroke: Stroke (in mm) that should be set on the setting tool to give the **Tubtara®** referred to, the adequate deformation.

Pull-out or Ultimate Thread Strength: Surpassing this ultimate force (in Newton), the thread of the set **Tubtara®** will be pulled out.

The mentioned values are average reference values only.

We strongly advise the customer to do his own tests in the proper material thickness and specific application.

Semi-hex parts have a setting force which is 10 to 15% lower than full hex or round parts but have the same fixation strength.

● **Testing methods**

In addition to the standard inspections during the production process the following tests can be done on customer's request :

- Pull-out test
- Maximum torque
- Push-out test
- Shear test
- Torque-to-turn
- Length under plate
- Size bulb forming

● **HX Tubtara[®] with seal under the head**

Information about NBR O-Ring & compatibility with other products					
Shore Hardness	70 - 95	Aromatic Hydrocarbons	x	Lye	x
Hydraulic fluids	xxxx	Aliphatic Hydrocarbons	xxx	Chlorinated Hydrocarbons	x
Fuel Oils	xx	Water under 80°C	xxx	Ozone & Sunlight	x
Organic Oils	xxxx	Water over 80°C	x	Temperature range °C	-35 +120
Brake Fluid	-	Alcohols	xx	Electr. properties	-
Silicone & Grease	xx	Ketone	-	Compression sets	xxx
Gasoline	xxx	Acid (concentrated)	-	Flame resistance	No
Aromatic fluids up to 50 %	xx	Acid (diluted)	x		
Kerosene	xxx				

Key: xxxx very good --> x satisfactory - not suitable.

Storage: protect against UV-light; store in a dry and dark place (all boxes are marked)

Seals in other materials like Viton or EPDM on request.

● **(H)DPX Tubtara[®] with seal under the head**

Information about the non-reactive, peripheral seal, made of flexible organic based material:

Material	Polyurethane	Reusability	yes
Colour	blue	Bead form	concave
Sealing capacity	> 150 bar	Cure method	heat cure
Temperature range	-40 +100 °C**	Waterproof	IP67 *
Shore hardness	50 A range		

Compatibility with other products : resistant to many automotive oils, antifreeze and transmission fluids.

* The seal reassures an IP67 waterproof Tubtara[®]-sheet assembly if correctly installed (only guaranteed under Dejong test conditions, certificates available)

Storage : min. 4 years shelf-life if stored in dry conditions (room temperature)

** For continuous usage, 150°C possible for intermittent use subject testing.

● Conversion table

Multiply	by	To get
millimeter (mm)	.03937	inch (in)
inch (in)	25,4	millimeter (mm)
kilogram (kg)	2,2046	pound (lb)
pound (lb)	0,4536	kilogram (kg)
Newton (N)	0,2248	pound-force (lbf)
Newton metre (Nm)	8,8507	pound-inch (Lb-In)

3D drawings

See our website www.tubtara.com and click on '3D drawings'

3D and 2D drawings available for all **Tubtara**® stainless steel blind rivet nuts:

- downloadable in installed or uninstalled condition
- user input option for exact grip
- multiple formats supported (DWG, STP, SolidWorks, Autodesk, Spaceclaim, AutoCAD, etc.)
- ability to insert **Tubtara**® CAD drawings directly into the product design

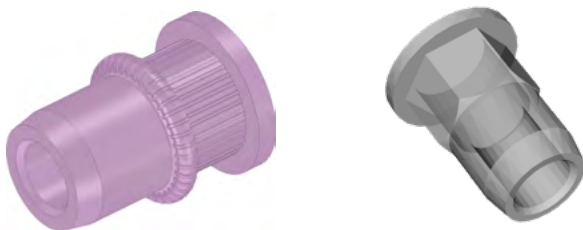

External website hosted by "Traceparts online":

www.tracepartsonline.net/ws/dejond

Quality

Statements on Reach / RoHS / Conflict Minerals:

- see our website www.tubtara.com or www.dejond.com
- contact our customer service for updated information.

EN 9100 - AS 9100 - JISQ 9100 certified



DEJOND IS NOT LIABLE FOR ANY PRINTING ERRORS AND RESERVES THE RIGHT TO CHANGE ALL DATA CONTAINED IN THIS CATALOGUE WITHOUT PRIOR NOTICE

Information cannot be copied or reproduced without permission of Dejond nv

General conditions available on our website www.dejond.com

Any dispute will fall within the exclusive jurisdiction of the courts of Antwerp

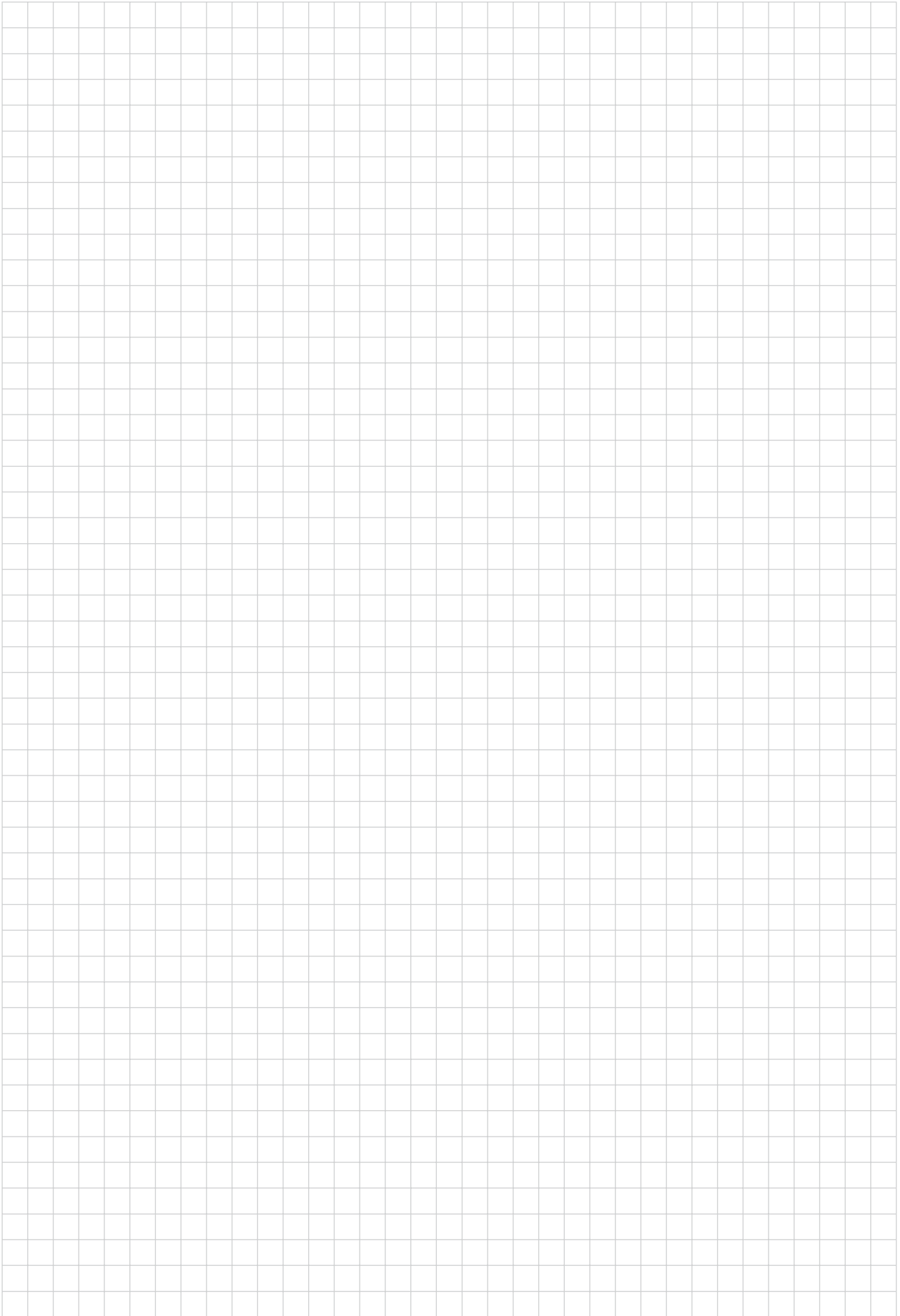

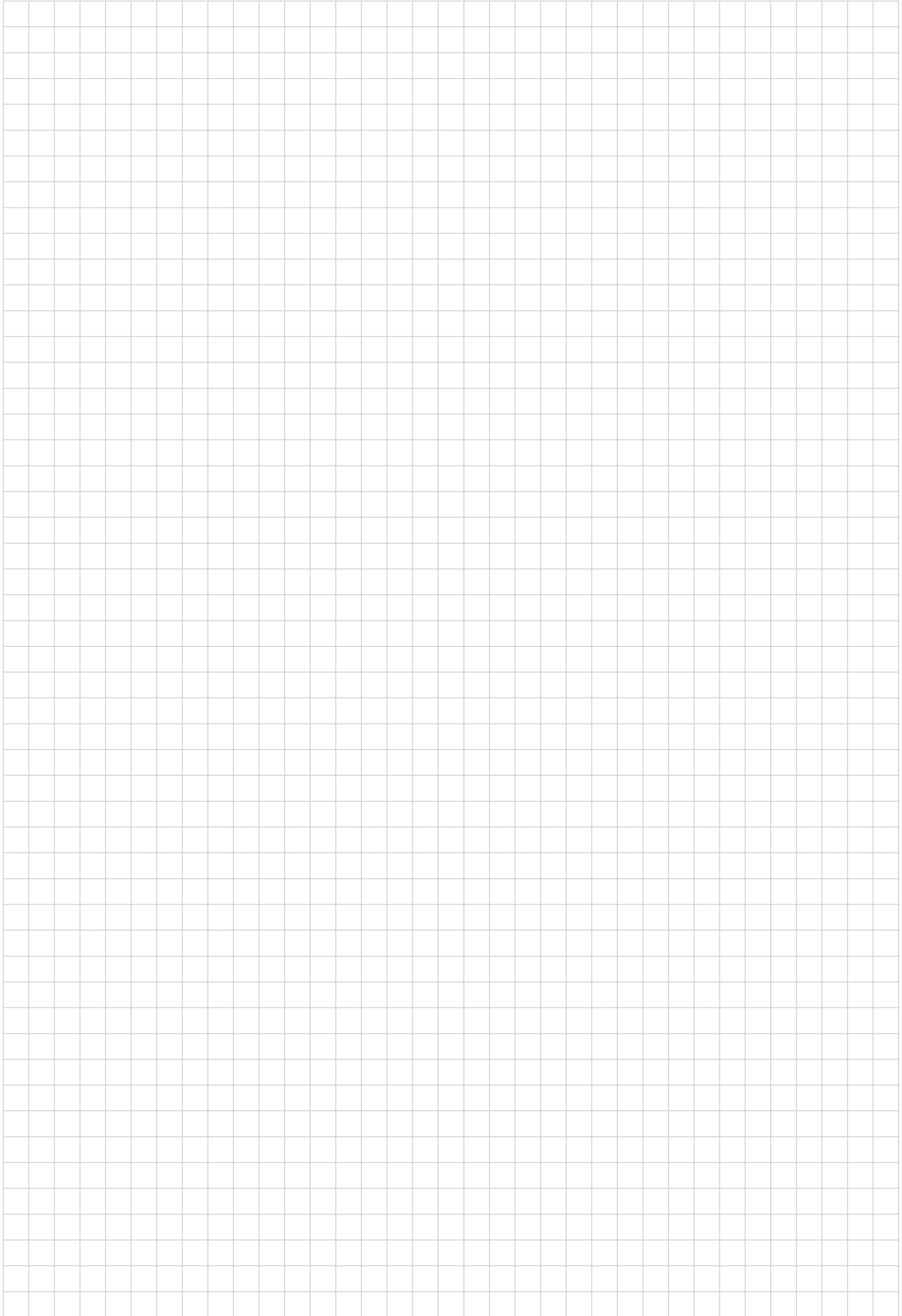



Tubtara® blind rivet nuts manufactured by Dejong Cold Forming Devison

A leading fastener brand because of:

- EN 9100 certification, approved for aerospace and defence
- Excellent and consistent quality thanks to a highly controlled production process
- In-house R&D team providing profound technical support
- Engagement to think along with the customer
- Product developments and customised solutions for every application
- Reliable production lead times
- Worldwide distributor network of dedicated fastener specialists
- Pro-active and personalised customer service and tech sales support
- High stock levels ensuring quick deliveries
- Specialised in cold formed stainless steel and watertight solutions
- Made in Belgium since 1954

For more information, visit our website:

www.tubtara.com



Dejong nv
Terbekehofdreef 55-59
2610 Wilrijk (Antwerp)
Belgium - Europe

T +32 3 820 34 36
tubtara@dejong.com

www.tubtara.com

