

HB Hysteresis Brakes and MHB Matched Brakes

FEATURES

- Torque up to 3500 oz-in/26 N·m
- Speed up to 20,000 rpm
- Power up to 2400 W
- Available in Metric or English dimensions
- Torque independent of speed
- Long, maintenance-free life
- Operational smoothness
- Superior torque repeatability
- Broad speed range
- Excellent environmental stability



DESCRIPTION

Magtrol pioneered the technology of applying the principles of hysteresis to meet the critical needs for reliable, smooth and adjustable torque control. Magtrol's Hysteresis Brakes produce torque strictly through a magnetic air gap without the use of magnetic particles or friction components. This method of braking provides far superior operating characteristics (smoother torque, longer life, superior repeatability, high degree of controllability, and less maintenance and down time) which make them the preferred choice for precise tension control during the processing of nearly any material, web or strand.

MATCHED BRAKES

In tension control applications that have multiple webs or multiple strands, it is very desirable to match the tension of each web or strand. This is most commonly attained by using a closed-loop servo control system which controls current to a braking device through the use of dancer arms, follower arms and in-line tension transducers. The problem with such systems is that each web or strand must be individually controlled, increasing the cost and complicating the system with multiple sensors and power supplies.

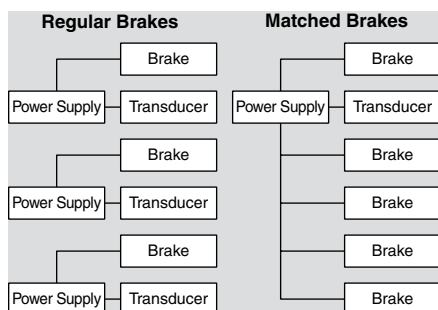

To solve this problem, Magtrol developed a system to assure that every brake of a given model designation will be matched—at a predetermined torque and current

point—to other brakes of the same model designation. Regardless of material and manufacturing tolerances, each brake is matched at the selected match point to within a tolerance of $\pm 1\%$. The maximum deviation in torque from brake to brake at any point along their torque/current curve (from 0 torque up to the selected matched torque point) is less than $\pm 4\%*$ of the selected matched torque value. With this level of matching, a system with multiple tension rollers would provide tension consistency within $\pm 1\%$ if set at the matched point with all brakes receiving the same current. The matched point can be any value between 50% and 100% of rated torque, which allows the brakes to be optimized for specific applications. Unless otherwise specified, all brakes are matched at 100 rpm.

APPLICATIONS

- Precise control of wire tension during wind, hook and cut operation of high-speed automated winding machines
- Frictionless, non-breakaway force for tensioning materials during slitting and many other material processing operations
- Load simulation applications for life testing on electric motors, actuators, small gas engines, gearboxes, and many other rotating devices and assemblies
- Open-loop control for maintaining precise tension during winding process in transformer and coil winding operations
- Holding of backdriving loads
- Ultimate tension control, regardless of control scheme—dancer roll, follower arm, photo or ultrasonic sensors
- Precise load control and programmed repeatability in fitness machines

**Contact Magtrol for more information*

PRINCIPLES OF HYSTERESIS

Overview

The hysteresis effect in magnetism is applied to torque control by the use of two basic components – a reticulated pole structure and a specialty steel rotor/shaft assembly – fastened together but not in physical contact. Until the field coil is energized, the drag cup can spin freely on the ball bearings. When a magnetizing force from either a field coil or magnet is applied to the pole structure, the air gap becomes a flux field. The rotor is magnetically restrained, providing a braking action between the pole structure and rotor.

Because torque is produced strictly through a magnetic air gap, without the use of friction or shear forces, Magtrol Hysteresis Brakes provide absolutely smooth, infinitely controllable torque loads, independent of speed, and they operate quietly without any physical contact of interactive members. As a result, with the exception of shaft bearings, no wear components exist.

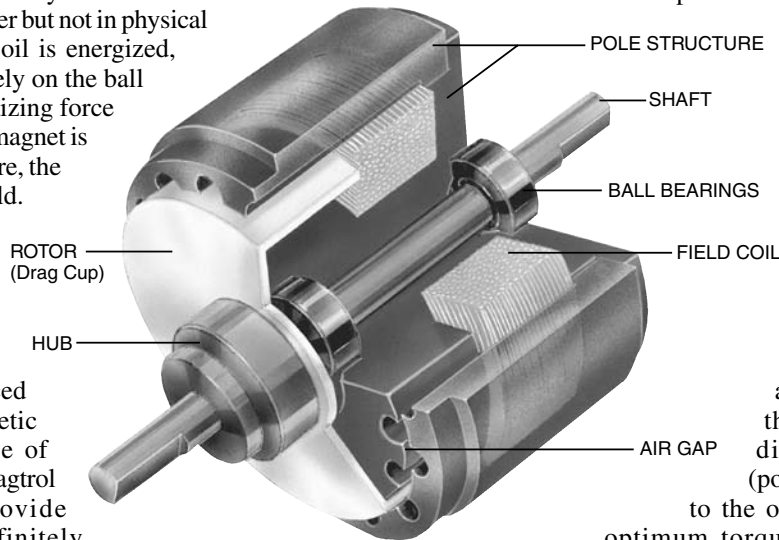

Control

In an electrically operated Hysteresis Brake, adjustment and control of torque is provided by a field coil. This allows for complete control of torque by adjusting DC current to the field coil. Adjustability from a minimum value (bearing drag) to a maximum value of rated torque is possible. Additional torque in the range of 15-25% above rated torque may be available on some brakes.

The amount of braking torque transmitted by the brake is proportional to the amount of current flowing through the field coil. The direction of current flow (polarity) is of no consequence to the operation of the brake. For optimum torque stability, a DC supply with current regulation is recommended. This will help to minimize torque drift attributable to changes in coil temperature and in-line voltage, which can result in changes in coil current, and consequently, in torque.

ADVANTAGES OF HYSTERESIS DEVICES

Long, Maintenance-Free Life

Magtrol Hysteresis Brakes produce torque strictly through a magnetic air gap, making them distinctly different from mechanical-friction and magnetic particle devices. Because hysteresis devices do not depend on friction or shear forces to produce torque, they do not suffer the problems of wear, particle aging, and seal leakage. As a result, hysteresis devices typically have life expectancies many times that of friction and magnetic particle devices.

Life Cycle Cost Advantages

While the initial cost of hysteresis devices may be the same or slightly more than that of their counterparts, the high cost of replacing, repairing and maintaining friction and magnetic particle devices often makes hysteresis devices the most cost-effective means of tension and torque control available.

Excellent Environmental Stability

Magtrol hysteresis devices can withstand significant variation in temperature and other operating conditions. In addition, because they have no particles or contacting active parts, Hysteresis Brakes are extremely clean. Magtrol devices are used in food and drug packaging operations, in clean rooms, and environmental test chambers.

Operational Smoothness

Because they do not depend on mechanical friction or particles in shear, Hysteresis Brakes are absolutely smooth at any speed. This feature is often critical in wire drawing, packaging and many other converting applications.

Superior Torque Repeatability

Because torque is generated magnetically without any contacting parts or particles, Hysteresis Brakes provide superior torque repeatability. Friction and magnetic particle devices are usually subject to wear and aging with resultant loss of repeatability. Magtrol devices will repeat their performance precisely, to ensure the highest level of process control.

Broad Speed Range

Magtrol hysteresis devices offer the highest slip speed range of all electric torque control devices. Depending on size, kinetic power requirements and bearing loads, many Magtrol Brakes can be operated at speeds in excess of 10,000 rpm. In addition, full torque is available even at zero slip speed and torque remains absolutely smooth at any slip speed.

ENGLISH RATINGS (FOR METRIC RATING SEE PAGE 5)

Hysteresis Brake Model	Matched Brake Model	Min. Torque at Rated Current	Rated Current	Voltage*	Maximum Speed	Kinetic Power**	
						5 Minutes	Continuous
		<i>oz·in</i>	<i>mA</i>	<i>VDC</i>	<i>rpm</i>	<i>W</i>	<i>W</i>
---	MHB-2.5	2.5	98	26.0	20 000	20	7
HB-2.5	---	2.5	146	25.0	20 000	20	5
HB-10	MHB-10	10	133	24.0	20 000	45	12
HB-16	---	16	192	24.0	20 000	75	20
HB-38	MHB-38	38	250	26.3	15 000	90	25
HB-50	MHB-50	50	253	24.0	15 000	90	23
HB-140	MHB-140	140	253	24.0	12 000	300	75
HB-250	MHB-250	250	270	25.9	10 000	450	110
HB-450	MHB-450	450	442	22.1	8 000	670	160
HB-750	MHB-750	750	383	23.0	7 000	1 000	200
HB-840	---	840	600	24.0	6 000	1 340	300
HB-1750	MHB-1750	1750	500	26.0	6 000	1 200	350
HB-3500	---	3500	1000	26.0	6 000	2 400	600

Hysteresis Brake Model	Matched Brake Model	Drag Torque De-energized @ 1000 rpm	Nominal Power	Resistance at 25°C ±10%	External Inertia	Angular Acceleration	Weight
		<i>oz·in</i>	<i>W</i>	Ω	<i>lb·in·s²</i>	<i>rad/s²</i>	<i>lb</i>
---	MHB-2.5	0.05	2.53	262	3.8×10^{-6}	41 100	0.24
HB-2.5	---	0.05	3.70	171	3.8×10^{-6}	41 100	0.24
HB-10	MHB-10	0.10	3.18/	180	3.3×10^{-5}	18 939	0.49
HB-16	---	0.10	4.60	125	5.6×10^{-5}	17 900	0.65
HB-38	MHB-38	0.20	6.60	105	8.6×10^{-5}	27 600	1.06
HB-50	MHB-50	0.20	6.10	95	1.478×10^{-4}	21 000	1.72
HB-140	MHB-140	0.70	6.10	95	9.1×10^{-4}	9 620	4.06
HB-250	MHB-250	1.00	7.00	96	2.75×10^{-3}	5 680	7.73
HB-450	MHB-450	2.00	9.80	50	6.55×10^{-3}	4 290	12.90
HB-750	MHB-750	7.00	8.80	60	1.283×10^{-2}	3 450	28.30
HB-840	---	4.00	14.40	40	1.31×10^{-2}	4 010	26.30
HB-1750	MHB-1750	13.00	13.00	52	5.28×10^{-2}	2 070	54.00
HB-3500	---	19.20	26.00	26	1.056×10^{-1}	2 070	110.00

* Other coil voltages are available.

** Kinetic power ratings are maximum values based on limiting coil and/or bearing temperature to approximately 100 °C, and should not be exceeded. Actual values in service may vary ±50% depending on mounting, ventilation, ambient temperature, etc.

ENGLISH BRAKE DIMENSIONS

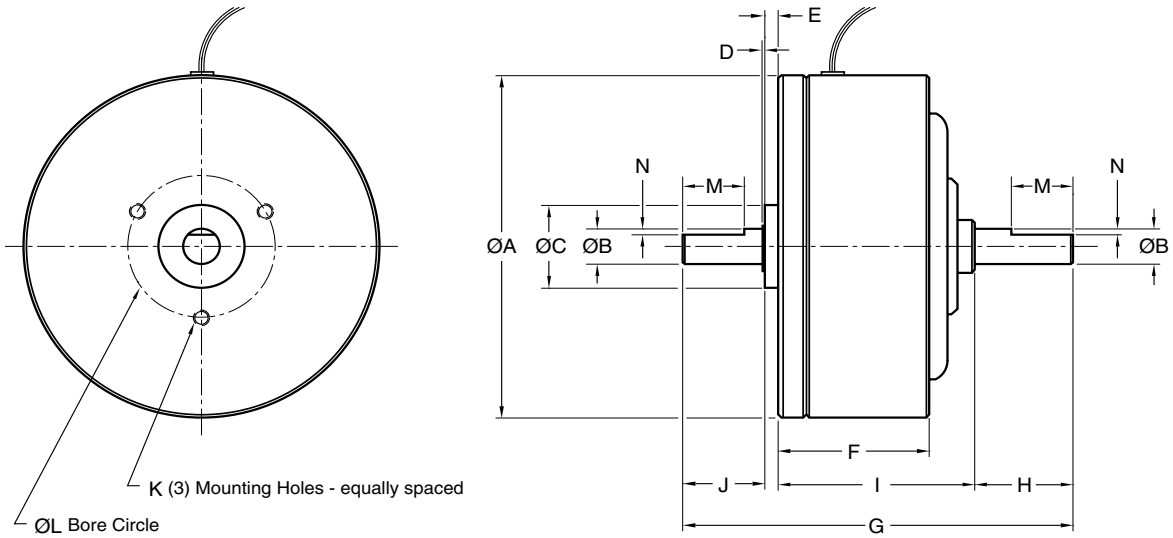

Hysteresis Brake Model	Matched Brake Model	ØA	ØB	ØC	D	E	F	G	H	I	J	K	L	M	N
---	MHB-2.5	1.250	0.1250	0.375	0.010	0.030	0.73	1.564	0.30	0.94	0.29	#4-40 × 0.16	0.750	---	---
HB-2.5	---	1.250	0.1250	0.375	0.012	0.030	0.73	1.564	0.29	0.94	0.29	#4-40 × 0.16	0.750	---	---
HB-10	MHB-10	1.800	0.1875	0.500	0.021	0.096	0.82	2.120	0.50	1.00	0.50	#4-40 × 0.19	0.687	0.375	0.025
HB-16	---	1.970	0.1875	0.500	0.015	0.096	0.81	2.109	0.51	0.95	0.55	#4-40 × 0.19	0.750	0.375	0.025
HB-38	MHB-38	2.155	0.2500	0.625	0.032	0.096	1.25	3.000	0.56	1.69	0.63	#6-32 × 0.25	0.906	0.375	0.025
HB-50	MHB-50	2.360	0.2500	0.625	0.033	0.096	1.56	3.000	0.56	1.69	0.63	#6-32 × 0.25	0.906	0.375	0.025
HB-140	MHB-140	3.624	0.3750	0.875	0.025	0.140	1.53	3.968	1.00	2.00	0.80	#8-32 × 0.37	1.500	0.625	0.060
HB-250	MHB-250	4.437	0.5000	1.125	0.035	0.156	1.98	4.718	1.06	2.53	0.93	#10-32 × 0.50	1.750	0.625	0.060
HB-450	MHB-450	5.420	0.5000	1.125	0.035	0.156	2.06	5.156	1.06	2.87	1.03	#10-32 × 0.38	1.750	0.630	0.060
HB-750	MHB-750	6.220	0.6250	1.375	0.035	0.163	2.87	6.930	1.50	3.74	1.50	¼-20 × 0.44	2.750	0.750	0.060
HB-840	---	5.485	0.5000	*	*	*	4.13	7.750	1.00	*	1.00	*	*	0.625	0.060
HB-1750	MHB-1750	8.900	1.0000	2.000	0.055	0.250	3.00	8.312	2.04	4.18	1.79	¼-20 × 0.50	3.000	#807 woodruff keyway (2 places)	
HB-3500	MHB-3500	8.900	1.0000	*	*	*	6.00	12.460	2.04	*	2.04	*	*	#807 woodruff keyway (2 places)	

* HB-840 and HB-3500 are double brake assemblies that require base mounting. See base mounting under "Brake Options" for details. Magtrol manufactures double brakes to increase torque capability. For more information and a drawing, contact Magtrol.

METRIC RATINGS

Hysteresis Brake Model	Matched Brake Model	Min. Torque at Rated Current <i>Nm</i>	Rated Current <i>mA</i>	Voltage* <i>VDC</i>	Maximum Speed <i>rpm</i>	Kinetic Power**	
						5 Minutes <i>W</i>	Continuous <i>W</i>
HB-3M-2	MHB-3M-2	0.02	145	25.0	20 000	20	5
HB-10M-2	MHB-10M-2	0.07	133	24.0	20 000	35	8
HB-20M-2	MHB-20M-2	0.14	217	26.0	20 000	50	12
HB-50M-2	MHB-50M-2	0.35	253	24.0	15 000	90	23
HB-140M-2	MHB-140M-2	1.00	253	24.0	12 000	300	75
HB-250M-2	MHB-250M-2	1.75	270	25.9	10 000	450	110
HB-450M-2	MHB-450M-2	3.20	442	22.1	8 000	670	160
HB-750M-2	MHB-750M-2	5.00	383	23.0	7 000	1 000	200
HB-1750M-2	MHB-1750M-2	§ 13.00	600	31.2	6 000	1 200	350
HB-3500M-2	---	§§ 26.00	1200	31.2	6 000	2 400	600

Hysteresis Brake Model	Matched Brake Model	Drag Torque De-energized @ 1000 rpm	Nominal Power	Resistance at 25°C ±10%	External Inertia	Angular Acceleration	Weight
		<i>Nm</i>	<i>W</i>	Ω	<i>kg-cm²</i>	<i>rad/s²</i>	<i>kg</i>
HB-3M-2	MHB-3M-2	3.53×10^{-4}	3.59	171	4.30×10^{-3}	46 600	0.11
HB-10M-2	MHB-10M-2	7.06×10^{-4}	3.18	180	4.35×10^{-2}	16 100	0.22
HB-20M-2	MHB-20M-2	7.77×10^{-4}	5.60	120	4.58×10^{-2}	30 600	0.29
HB-50M-2	MHB-50M-2	1.55×10^{-3}	6.10	95	1.67×10^{-1}	21 000	0.78
HB-140M-2	MHB-140M-2	5.42×10^{-3}	6.10	95	1.00×10^0	9 620	1.85
HB-250M-2	MHB-250M-2	7.77×10^{-3}	7.00	96	3.45×10^0	5 680	3.50
HB-450M-2	MHB-450M-2	1.51×10^{-2}	9.80	50	7.50×10^0	4 290	5.86
HB-750M-2	MHB-750M-2	5.00×10^{-2}	8.80	60	1.45×10^1	3 450	12.85
HB-1750M-2	MHB-1750M-2	9.18×10^{-2}	13.00	52	6.25×10^1	2 070	24.50
HB-3500M-2	---	1.36×10^{-1}	26.00	28	1.25×10^2	2 070	50.00

§ 13 Nm is attainable @ approx. 600 mA. This value may decrease to 12.36 N-m if the brake is powered by any power supply or controller limited to 500 mA.

§§ 26 Nm is attainable @ approx. 1200 mA. This value may decrease to 24.72 N-m if the brake is powered by any power supply or controller limited to 1000 mA.

* 90 volt and non-standard coil voltages are available. 12 VDC coils are available on HB-3M-2 through HB-450M-2 models.

** Kinetic power ratings are maximum values based on limiting coil and/or bearing temperature to approximately 100 °C, and should not be exceeded. Actual values in service may vary ±50% depending on mounting, ventilation, ambient temperature, etc.

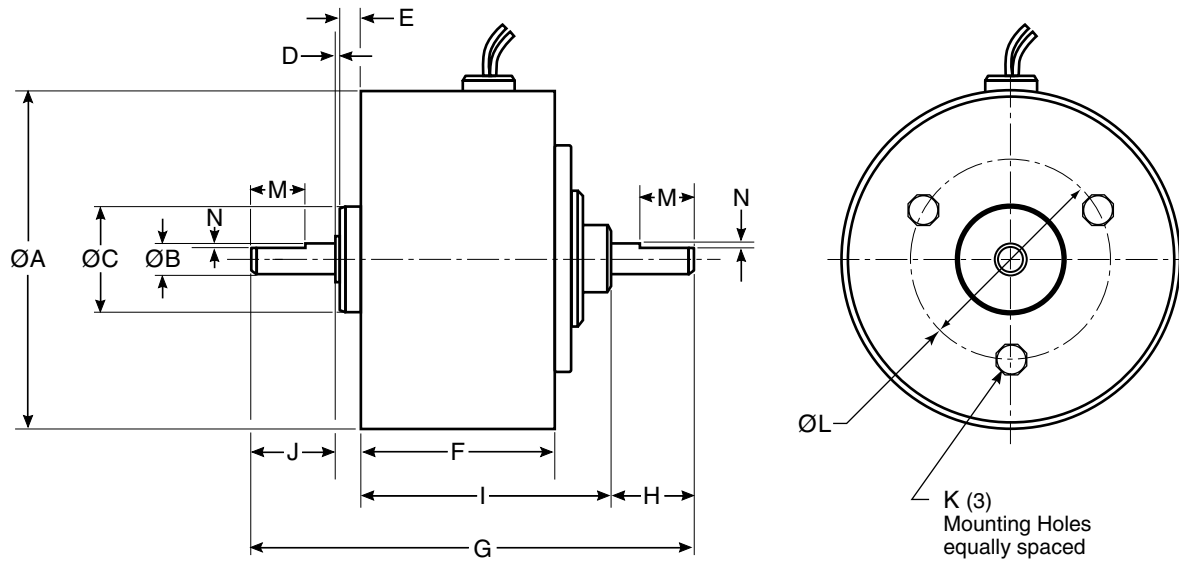
METRIC BRAKE DIMENSIONS

Hysteresis Brake Model	Matched Brake Model	ØA	ØB	ØC	D	E	F	G	H	I	J	K	ØL	M	N
HB-3M-2	MHB-3M-2	31.8	3.00	10.00	0.6	2.0	18.6	42.0	8.0	23.6	8.0	M2.5 × 4	19.0	---	---
HB-10M-2	MHB-10M-2	45.7	5.00	14.00	0.7	2.4	20.7	52.6	12.0	25.5	12.0	M2.5 × 5	19.0	9.5	0.7
HB-20M-2	MHB-20M-2	50.0	5.00	14.00	0.7	1.8	23.5	55.8	13.0	27.3	13.0	M3 × 6	21.0	9.5	0.7
HB-50M-2	MHB-50M-2	60.0	7.00	17.00	0.7	2.0	39.7	76.5	15.0	42.8	16.0	M4 × 8	25.0	10.0	0.7
HB-140M-2	MHB-140M-2	92.0	10.00	22.00	0.8	2.5	39.0	100.0	25.0	50.8	21.0	M4 × 9	38.0	16.0	1.0
HB-250M-2	MHB-250M-2	112.7	12.00	28.00	0.7	3.9	50.4	123.1	27.0	64.2	27.0	M5 × 10	45.0	4x4x20 round end keyway (2 places)	
HB-450M-2	MHB-450M-2	137.7	15.00	32.00	0.9	3.5	52.4	131.5	27.0	73.0	27.0	M5 × 10	60.0	5x5x20 round end keyway (2 places)	
HB-750M-2	MHB-750M-2	158.0	17.00	35.00	0.9	4.0	73.0	176.0	38.0	95.0	38.0	M6 × 10	70.0	5x5x20 round end keyway (2 places)	
HB-1750M-2	MHB-1750M-2	226.1	25.00	52.00	1.2	6.0	76.2	213.0	50.0	105.8	50.0	M6 × 12	100.0	8x7x25 round end keyway (2 places)	
HB-3500M-2*	---	226.0	25.00	N/A	N/A	N/A	152.4	312.0	50.0	212.0	50.0	N/A	N/A	8x7x25 round end keyway (2 places)	

* The HB-3500M-2 is a double brake assembly that requires base mounting. See base mounting under "Brake Options" for details. Magtrol manufactures double brakes to increase torque capability. For more information and a drawing, contact Magtrol.

PILLOW BLOCK DIMENSIONS

Pillow Block Assemblies are an available option for all brake units except the HB-3500 and HB-3500M.

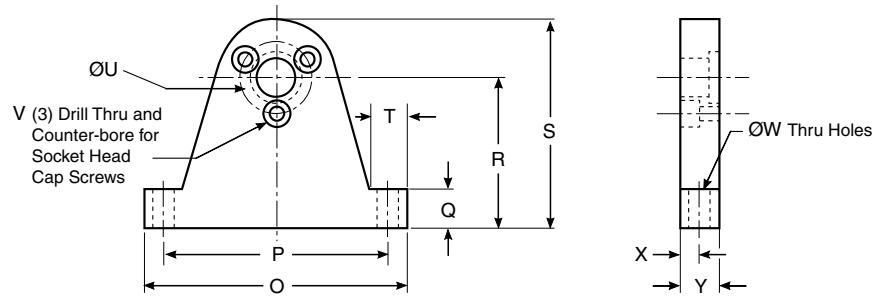

ENGLISH DIMENSIONS												
Pillow Block Model	For Brake Models	O	P	Q	R	S	T	ØU	V	ØW	X	Y
4736	HB-2.5, MHB-2.5	1.75	1.500	0.31	1.000	1.500	0.25	0.750	#4-40	0.125	0.125	0.25
4702	HB-8, MHB-10.5	2.50	2.125	0.37	1.437	2.120	0.38	0.687	#4-40	0.201	0.187	0.38
4703	HB-16	2.50	2.125	0.37	1.437	2.120	0.38	0.750	#4-40	0.201	0.187	0.38
4705	HB-32, HB-50, MHB-38, MHB-50	2.50	2.125	0.37	1.437	2.120	0.38	0.906	#6-32	0.201	0.187	0.38
4711	HB-140, MHB-140	4.00	3.500	0.37	2.000	3.190	0.50	1.500	#8-32	0.201	0.250	0.50
4714	HB-250, MHB-250	4.00	3.500	0.37	2.375	3.690	0.50	1.750	#10-32	0.201	0.250	0.50
4717	HB-450, MHB-450	4.62	4.000	0.50	3.000	4.310	0.56	1.750	#10-32	0.201	0.250	0.50
4720	HB-750, MHB-750	5.25	4.500	0.75	3.250	5.125	0.75	2.750	¼-20	0.343	0.375	0.75
4722	HB-1750, MHB-1750	7.50	6.500	1.00	5.000	7.000	1.00	3.000	¼-20	0.328	0.500	1.00

METRIC DIMENSIONS												
Pillow Block Model	For Brake Models	O	P	Q	R	S	T	ØU	V	ØW	X	Y
4723	HB-3M-2, MHB-3M-2	44.5	38.0	6.4	25.4	38.1	7.4	19.0	M2.5	3.4	3.2	6.4
4700	HB-10M-2, MHB-10M-2	63.5	54.0	9.7	36.5	53.9	10.4	19.0	M2.5	5.5	4.7	9.5
4704	HB-20M-2, MHB-20M-2	63.5	54.0	9.7	36.5	53.9	10.4	21.0	M3	5.5	4.7	9.5
4706	HB-50M-2, MHB-50M-2	63.5	54.0	9.7	36.5	53.9	10.4	25.0	M4	5.5	4.7	9.5
4864	HB-140M-2, MHB-140M-2	101.6	90.0	9.7	50.0	80.9	12.7	38.0	M4	4.5	6.4	12.7
4865	HB-250M-2, MHB-250M-2	101.6	90.0	9.7	60.0	93.7	12.7	45.0	M5	5.5	6.4	12.7
4866	HB-450M-2, MHB-450M-2	117.3	104.0	12.7	76.0	120.4	14.2	60.0	M5	6.6	6.4	12.7
4858	HB-750M-2, MHB-750M-2	133.4	115.0	19.1	83.0	130.6	19.1	70.0	M6	9.0	9.5	19.1
4867	HB-1750M-2, MHB-1750M-2	190.5	166.0	25.4	120.0	177.8	25.4	100.0	M6	11.0	12.7	25.4

BASE MOUNT DIMENSIONS

Base mounting is standard on all HB-840, HB-3500 and HB-3500M brakes, and is an available option on all other brakes.

Base Mount Ordering Information

An HB-1750 with optional base mount is an HB-1751.

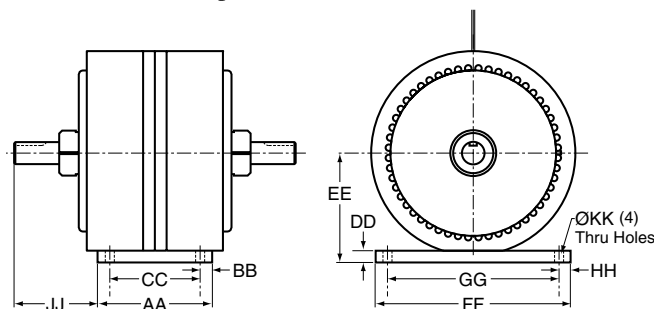

All other dimensions per standard brakes

ENGLISH DIMENSIONS										
Model	AA	BB	CC	DD	EE	FF	GG	HH	JJ	ØKK
HB-451	2.50	0.25	2.00	0.50	3.15	5.25	4.75	0.25	*	0.201
HB-840	4.13	0.25	3.63	0.50	3.15	5.25	4.75	0.25	1.81	0.204
HB-1751	4.00	0.50	3.00	0.50	4.75	9.00	8.00	0.50	*	0.406
HB-3500	5.00	0.50	4.00	0.50	4.75	8.50	7.50	0.50	3.73	0.406

METRIC DIMENSIONS										
Model	AA	BB	CC	DD	EE	FF	GG	HH	JJ	ØKK
HB-1751M	101.5	12.7	76	12.6	120.7	215.9	190	13	*	11
HB-3500M	127.0	13.5	100	12.7	120.7	216.0	190	13	92.5	11

* Contact Magtrol for drawing.

SPECIAL DESIGNS

Since 1953, Magtrol has created literally thousands of special and modified brake designs to help solve specific application problems for our customers.

Common Modifications

- Non-Standard Coil Voltages
- Special Shaft Configurations: keyways, flats, holes and hollow
- Dust Covers
- Speed Pickups
- Special Mounting Configurations
- Non-Standard Lead: material, lengths, location
- Higher Torque Devices
- High Speed Units

Higher Torque Capability

It is Magtrol's policy never to overstate the capabilities of our products. As a result, our brakes are conservatively rated. However, Magtrol can typically provide higher torque of up to 15% to 25% above rated value in the same size device to meet your requirements. Special designs capable of producing even higher torques are also available.

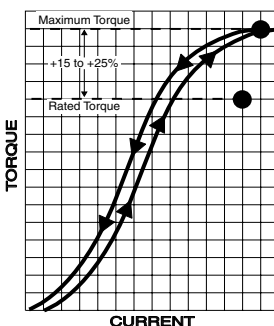

BRAKE OPTIONS

Torque Current Curves

Nominal performance characteristic curves similar to that shown above will be provided by Magtrol, upon request. Precise calibration curves for individual brakes can be provided, but must be specified at time of order and do require an additional charge.

Couplings

Although intended for coupled service, moderate overhung loads can be tolerated, depending on such operating characteristics as speed, weight, and center of gravity of load. Care should be taken to make certain that the shaft is properly aligned. Couplings should be of proper size and flexibility to adequately protect bearings from undue stress and shock loading.

POWER SUPPLIES

For optimum torque stability, Magtrol offers four different power supplies for its Hysteresis Brakes and Clutches:

Model 5200 Power Supply

The Model 5200 is an unregulated 0 to 35 VDC Power Supply which offers control and regulation of the braking torque via a 10 turn potentiometer. The 5200 is our most basic control for manual testing in an open loop torque control mode.



Model 5210 Current Regulated Power Supply

The Model 5210 provides the same control capabilities as the 5200, and also provides current regulation of the brake. With regulated current, the 5210 will eliminate torque drift caused by temperature changes within the brake coil.

Model 5250 Current Regulated Power Supply

Model 5250-2 is an open frame, current regulated power supply.

VM Series Proportional Amplifier/controller

The VM Series Proportional Amplifier/Controller is used to supply and control current (up to 3 A) to Magtrol Hysteresis Brakes and Clutches and Convection Powder Brakes. The analog inputs of the amplifier/controller are designed for 0-10 V or 4-20mA signals (using switches S1 and S2).

SOLID MODELS

Solid 3D models are available for most Magtrol Hysteresis Devices by contacting Customer Service:

E-mail: magsales@magtrol.com
Phone: 1-716-668-5555

Due to the continual development of our products, we reserve the right to modify specifications without forewarning.



www.magtrol.com

MAGTROL INC

70 Gardenville Parkway
Buffalo, New York 14224 USA
Phone: +1 716 668 5555
Fax: +1 716 668 8705
E-mail: magtrol@magtrol.com

MAGTROL SA

Route de Montena 77
1728 Rossens/Fribourg, Switzerland
Phone: +41 (0)26 407 3000
Fax: +41 (0)26 407 3001
E-mail: magtrol@magtrol.ch

Subsidiaries in:

Germany • France
China • India

Worldwide Network
of Sales Agents

