

COM Express®

miniBASE-10R User's Manual

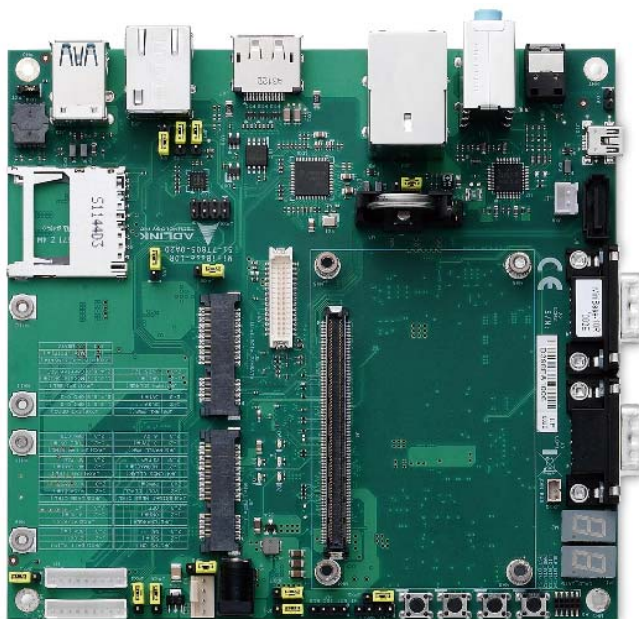

Manual Revision: 1.00
Revision Date: May 15, 2015
Part Number: 50-1V002-1000



ADLINK
TECHNOLOGY INC.

Revision History

Revision	Description	Date	By
1.00	Initial release	2015-05-15	JC

Preface

Copyright 2015 ADLINK Technology, Inc.

This document contains proprietary information protected by copyright. All rights are reserved. No part of this manual may be reproduced by any mechanical, electronic, or other means in any form without prior written permission of the manufacturer.

Disclaimer

The information in this document is subject to change without prior notice in order to improve reliability, design, and function and does not represent a commitment on the part of the manufacturer. In no event will the manufacturer be liable for direct, indirect, special, incidental, or consequential damages arising out of the use or inability to use the product or documentation, even if advised of the possibility of such damages.

Environmental Responsibility

ADLINK is committed to fulfill its social responsibility to global environmental preservation through compliance with the European Union's Restriction of Hazardous Substances (RoHS) directive and Waste Electrical and Electronic Equipment (WEEE) directive. Environmental protection is a top priority for ADLINK. We have enforced measures to ensure that our products, manufacturing processes, components, and raw materials have as little impact on the environment as possible. When products are at their end of life, our customers are encouraged to dispose of them in accordance with the product disposal and/or recovery programs prescribed by their nation or company.

Trademarks

Product names mentioned herein are used for identification purposes only and may be trademarks and/or registered trademarks of their respective companies.

Table of Contents

Revision History	2
Preface.....	3
1. Introduction	7
2. Features	8
2.1. Integrated Smart Battery Management System	8
2.2. Secondary BIOS.....	8
2.3. Integrated Debug Port with Single Step Execution	8
2.4. Onboard Audio	8
2.5. Information LEDs	8
2.6. Power, Reset, Lid and Sleep Switches	8
3. Component Location	9
4. Functional Block Diagram	10
5. Mechanical Dimensions	11
6. Connectors and Pinouts	12
6.1. Carrier Board Signals – Type 10.....	12
6.2. Connector and Pinout Compatibility	13
6.3. Carrier Board Design.....	13
6.4. COM Express Board-to-Board Connectors	14
6.5. Display Connectors	16
6.5.1. JX8: LVDS/eDP Connector	16
6.5.2. JY2: eDP Backlight Voltage	17
6.5.3. JX7: DP.....	17
6.6. LVDS Jumper Settings	18
6.6.1. JP5: Panel Power Voltage.....	18
6.6.2. JP6: Backlight Power Voltage	18
6.6.3. JP3: Brightness Control	18
6.6.4. JP7: Brightness PWM Source.....	18
6.7. Audio Connectors	19
6.7.1. JX2: S/PDIF Output Jack (optical)	19
6.7.2. JX6: S/PDIF Output Header	19
6.7.3. JX1: Three-in-One Audio Phone Jack.....	19
6.8. Mini PCIe and mSATA Connector	20
6.8.1. J2: Mini-PCIe Connector	20

6.8.2.	J5: Mini-PCle/mSATA Connector	21
6.8.3.	JPX8: Mini-PCle/mSATA Selection	23
6.9.	SATA	23
6.9.1.	J9: SATA	23
6.9.2.	JX9: Power for SATA	23
6.10.	USB and LAN	24
6.10.1.	J10: Mini-USB	24
6.10.2.	J13: USB 3.0 x 2	24
6.10.3.	JX14: USB 2.0 x 2 and GbE RJ-45	24
6.10.4.	JX3: GbE RJ-45	25
6.11.	Serial Ports	25
6.12.	I ² C, SMBus and CAN Bus	25
6.12.1.	H2: I2C Bus	25
6.12.2.	H1: SM Bus	26
6.12.3.	JX10: CAN Bus	26
6.13.	Fan Connector	26
6.13.1.	JPX4: Fan Type Selection	26
6.13.2.	JPX5: Fan Control	26
6.13.3.	H3: Fan Header	26
6.14.	Other Connectors	27
6.14.1.	JPX6: EXT GPIO	27
6.14.2.	JPY1: GPIO	27
6.14.3.	J7: SD Card Slot	27
6.14.4.	UX4: Secondary SPI BIOS Socket	27
6.14.5.	H5: CPLD_JTAG	28
6.15.	Other Jumpers	28
6.15.1.	JP4: Clear CMOS	28
6.15.2.	JPX7: BIOS Selection	28
6.16.	Power Connectors	29
6.16.1.	JX5: AC Adapter	29
6.16.2.	H4/H7: Smart Battery 1/2 Connectors	29
6.16.3.	JPY2: Smart Battery Configuration	29
6.16.4.	JPX1: Protection Selection	29
6.17.	Power Jumper Settings	30
6.17.1.	JPX2: AT/ATX Mode	30
6.17.2.	JPX3: 5VSB to Module Source	30
6.17.3.	JP1: PS_ON# Signal Source	30

7. Secondary BIOS	31
7.1. SPI Secondary BIOS.....	31
8. Switches, POST and LEDs.....	32
8.1. Switches (S1-S4).....	32
8.2. POST.....	32
8.3. Indicator LEDs	33
9. Smart Battery Management System	34
9.1. Input Power	34
9.2. Charger Output Capability	34
9.3. Key Characteristics	34
9.4. Battery Settings	34
9.5. Windows OS Interface	35
9.5.1. Device Presence	35
9.5.2. No Battery Power Subsystem Present	35
9.5.3. Battery Present	35
9.5.4. Battery State Notification.....	35
9.5.5. Battery Information.....	35
Safety Instructions	36
Getting Service	37

1. Introduction

The COM Express approach of custom carrier combined with off the shelf system cores is an excellent solution when you need to customize but lack the time or quantity for a complete redesign. It fits most system integration projects with production volumes from 500 to 10,000 pcs per year. The COM Express concept has a great many advantages over full custom designs, it reduces engineering complexity, lowers the threshold for total project quantity and last but not least brings your product to the market in no time. The average time to design a carrier board is less than half the time of a full custom OEM board.

The miniBASE-10R is a Mni-ITX size carrier board. Together with the COM Express Type 10 module of your choice and off-the-shelf add-on cards, you can quickly emulate the functionality of your desired end product for software development and hardware verification.

To build a functional prototype of your target system you will need:

- COM Express Type 10 module
- miniBASE-10R carrier board
- PCI Express based or USB based add on cards
- SATA storage or flash disk solution

The miniBASE-10R is compatible with Mini size Type 10 pinout COM Express modules and accommodates up to one Mini PCIe card, one Mini PCIe/mSATA card slot and one SD card.

The miniBASE-10R integrates a Smart Battery Management System that supports two Smart Batteries and 19V adapter input. The integrated Smart Battery Management System is compliant with the Smart Battery Manager Specification and uses the System Management Bus (SMBus) for communications between the battery power subsystem, Smart Batteries and host system (COM Express module). It is ACPI compliant and provides complete Smart Battery management under a supported operating system. ADLINK's COM Express Type 10 modules feature a BIOS that fully supports all Smart Battery communications using existing interfaces defined in the COM Express specification and are fully compatible with the integrated Smart Battery Management System. The integrated Smart Battery Management System is a proof-of-concept battery power subsystem that allows for quick development and integration of battery power into a COM Express system in the following ways:

- To emulate the battery power subsystem functionality of your prototype system during the design phase
- As a ready-made battery power subsystem for your customized system
- As a reference design to integrate a battery power subsystem into your custom-designed carrier

The miniBASE-10R is based on the PICMG COM Express (COM.0 Rev. 2.1) specification and follows the PICMG COM Express Carrier Design Guide (CDG) where possible (see 0 Carrier Board Design on page 13)

2. Features

2.1. Integrated Smart Battery Management System

The miniBASE-10R integrates a Smart Battery Management System that support Dual Smart Batteries and 19V adapter. The Smart Battery Management System is a proof-of-concept battery power system that allows for quick development and integration of battery power into a COM Express system.

The Smart Battery Management System use the SM Bus for communications between battery power system, Smart Batteries and COM Express module. It is ACPI compliant and provides complete battery management under a supporting operating system.

Note: The selected COM Express module for miniBASE-10R must support wide voltage range input. (5.7V - 14V), even if Smart Battery power is not used.

2.2. Secondary BIOS

The miniBASE-10R supports the Serial Peripheral Interface (SPI) for COM Rev. 2.1 modules. Selection of active BIOS can be made by jumper settings. The jumper of the secondary BIOS is JPX7.

2.3. Integrated Debug Port with Single Step Execution

In addition to a two-digit POST code display, the board also provides a four-digit address display. By jumper selection the board can be switched into single step BIOS execution mode. Steps are executed using a manually operated onboard mini switch.

2.4. Onboard Audio

The miniBASE-10R has a Realtek ALC262 audio codec onboard. Audio I/O is provided by a three-jack connector.

2.5. Information LEDs

General information is obtained through signaling LEDs for HDD and Power status. Additionally the miniBASE-10R gives information about module types being plug into the board. See 8.3 Indicator LEDs on page 29.

2.6. Power, Reset, Lid and Sleep Switches

The miniBASE-10R is equipped four mini switches (S1~4) for Reset, Power and COM.0 Rev.2.1 specified "Lid" and "Sleep" functions.

4. Functional Block Diagram

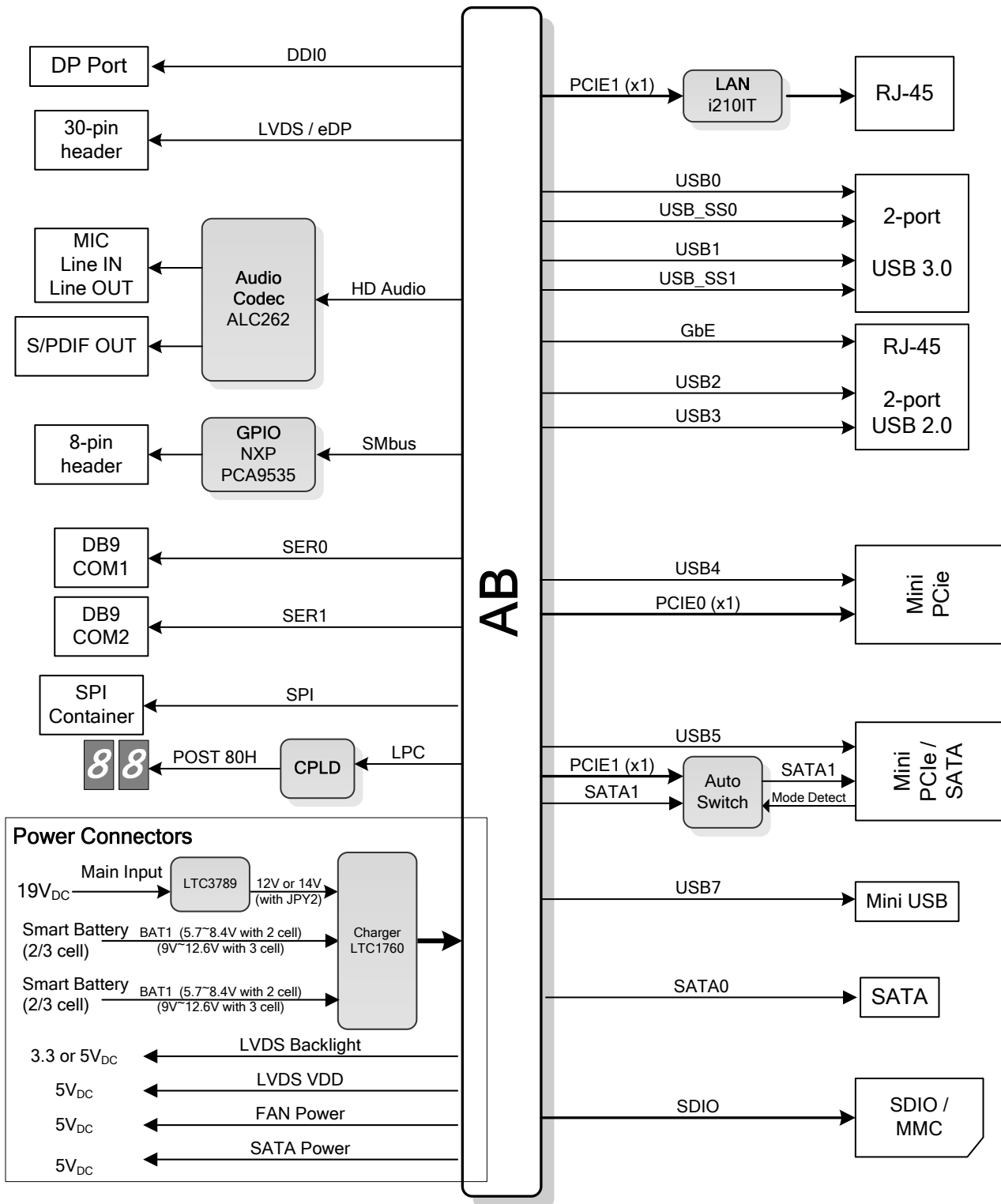

5. Mechanical Dimensions

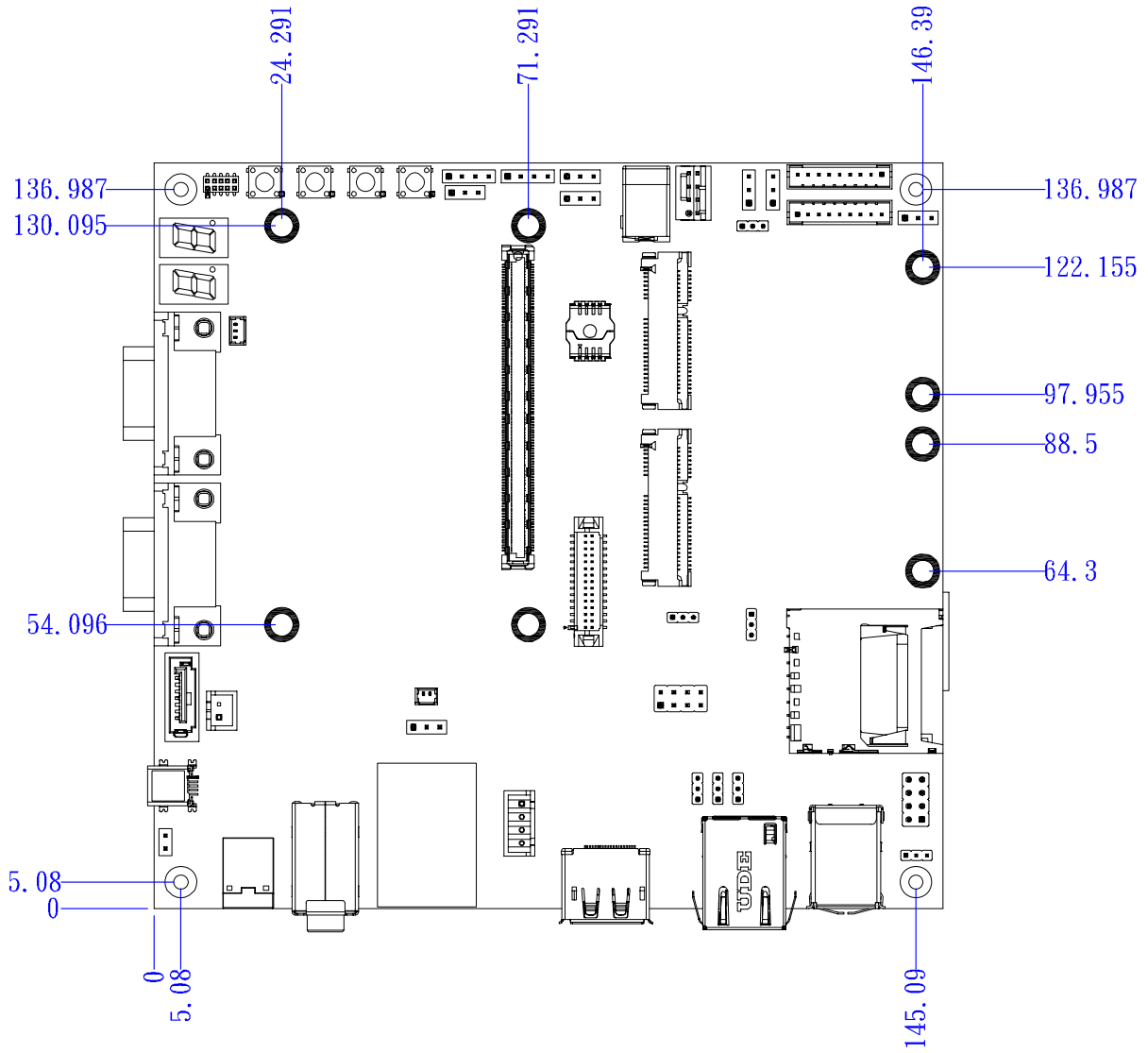

Dimensions: mm

All \varnothing tolerances ± 0.05 mm
 Other tolerances ± 0.2 mm

6. Connectors and Pinouts

6.1. Carrier Board Signals – Type 10

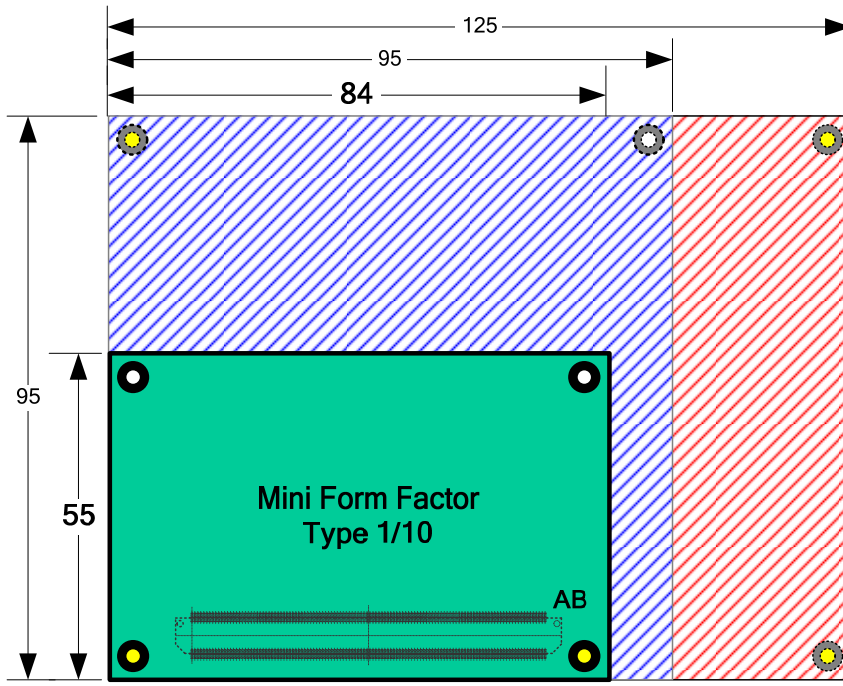

Dimensions in mm

- Gigabit Ethernet port
- LPC interface
- 2 Serial ATA channels
- AC'97 or High Definition Audio
- 7 USB 2.0 (one USB client) and 2 USB 3.0
- 3 PCI Express x1 Lanes
- Single 24-bit LVDS/eDP
 - Display Port
 - GPIO / SD
 - 2 COM Ports
 - I2C / SMBus
 - SPI support
- Primary power input:
 - +12V, +5V standby and 3.3V RTC
 - Smart Fan

AB Connector

6.2. Connector and Pinout Compatibility

Connectors positions and pinouts comply with pinout and signal descriptions in the "PICMG® COM.0 - COM Express Module Base specification, Revision 2". This document includes: description of pinouts, signal descriptions and mechanical characteristics of the COM Express specification. The miniBASE-10R is compatible with COM Express modules in mini size form factor, Type 10 pinout, COM.0 Rev. 2.1.

6.3. Carrier Board Design

The miniBASE-10R follows the PICMG COM Express Carrier Design Guide (CDG) where possible. The miniBASE-10R design and schematics are fully verified, and we recommend that you follow them as a reference for your carrier board design. miniBASE-10R Schematics and Mechanical files as well as the CDG can be downloaded from the miniBASE-10R product webpage: http://www.adlinktech.com/PD/web/PD_detail.php?cKind=&pid=1362



6.4. COM Express Board-to-Board Connectors

Signals and Pinout comply with
COM Express Type 10

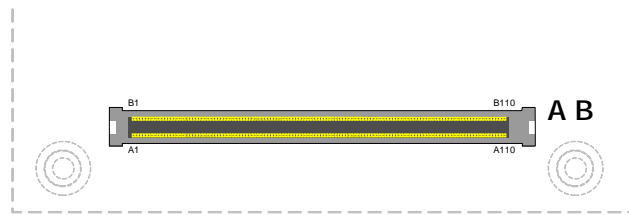

COM.0 Type 10 rev. 2.1

Pin	Row A	Row B
1	GND(FIXED)	GND(FIXED)
2	GBE0_MDI3-	GBE0_ACT#
3	GBE0_MDI3+	LPC_FRAME#
4	GBE0_LINK100#	LPC_AD0
5	GBE0_LINK1000#	LPC_AD1
6	GBE0_MDI2-	LPC_AD2
7	GBE0_MDI2+	LPC_AD3
8	GBE0_LINK#	LPC_DRQ0#
9	GBE0_MDI1-	LPC_DRQ1#
10	GBE0_MDI1+	LPC_CLK
11	GND(FIXED)	GND(FIXED)
12	GBE0_MDI0-	PWRBTN#
13	GBE0_MDI0+	SMB_CK
14	GBE0_CTREF	SMB_DAT
15	SUS_S3#	SMB_ALERT#
16	SATA0_TX+	SATA1_TX+
17	SATA0_TX-	SATA1_TX-
18	SUS_S4#	SUS_STAT#
19	SATA0_RX+	SATA1_RX+
20	SATA0_RX-	SATA1_RX-
21	GND(FIXED)	GND(FIXED)
22	USB_SSRX0-	USB_SSTX0-
23	USB_SSRX0+	USB_SSTX0+
24	SUS_S5#	PWR_OK
25	USB_SSRX1-	USB_SSTX1-
26	USB_SSRX1+	USB_SSTX1+
27	BATLOW#	WDT
28	(S)ATA_ACT#	AC/HDA_SDIN2
29	AC/HDA_SYNC	AC/HDA_SDIN1
30	AC/HDA_RST#	AC/HDA_SDIN0
31	GND(FIXED)	GND(FIXED)
32	AC/HDA_BITCLK	SPKR
33	AC/HDA_SDOUT	I2C_CK
34	BIOS_DIS0#	I2C_DAT
35	THRMTRIP#	THRM#
36	USB6-	USB7-
37	USB6+	USB7+
38	USB_6_7_OC#	USB_4_5_OC#
39	USB4-	USB5-
40	USB4+	USB5+
41	GND(FIXED)	GND(FIXED)
42	USB2-	USB3-
43	USB2+	USB3+
44	USB_2_3_OC#	USB_0_1_OC#
45	USB0-	USB1-
46	USB0+	USB1+
47	VCC_RTC	EXCD1_PERST#
48	EXCD0_PERST#	EXCD1_CPPE#
49	EXCD0_CPPE#	SYS_RESET#
50	LPC_SERIRQ	CB_RESET#
51	GND(FIXED)	GND(FIXED)

COM.0 Type 10 rev. 2.1

Pin	Row A	Row B
52	RSVD	RSVD
53	RSVD	RSVD
54	GPI0	GPO1
55	RSVD	RSVD
56	RSVD	RSVD
57	GND	GPO2
58	PCIE_TX3+	PCIE_RX3+
59	PCIE_TX3-	PCIE_RX3-
60	GND(FIXED)	GND(FIXED)
61	PCIE_TX2+	PCIE_RX2+
62	PCIE_TX2-	PCIE_RX2-
63	GPI1	GPO3
64	PCIE_TX1+	PCIE_RX1+
65	PCIE_TX1-	PCIE_RX1-
66	GND	WAKE0#
67	GPI2	WAKE1#
68	PCIE_TX0+	PCIE_RX0+
69	PCIE_TX0-	PCIE_RX0-
70	GND(FIXED)	GND(FIXED)
71	LVDS_A0+ / eDP_TX2+	DDIO_PAIR0+
72	LVDS_A0- / eDP_TX2-	DDIO_PAIR0-
73	LVDS_A1+ / eDP_TX1+	DDIO_PAIR1+
74	LVDS_A1- / eDP_TX1-	DDIO_PAIR1-
75	LVDS_A2+ / eDP_TX0+	DDIO_PAIR2+
76	LVDS_A2- / eDP_TX0-	DDIO_PAIR2-
77	LVDS_/eDP_VDD_EN	DDIO_PAIR4+
78	LVDS_A3+	DDIO_PAIR4-
79	LVDS_A3-	LVDS_/eDP_BKLT_EN
80	GND(FIXED)	GND(FIXED)
81	LVDS_A_CK+ / eDP_TX3+	DDIO_PAIR3+
82	LVDS_A_CK- / eDP_TX3-	DDIO_PAIR3-
83	LVDS_I2C_CK / eDP_AUX+	LVDS_/eDP_BKLT_CTRL
84	LVDS_I2C_DAT / eDP_AUX-	VCC_5V_SBY
85	GPI3	VCC_5V_SBY
86	RSVD	VCC_5V_SBY
87	eDP_HPDP	VCC_5V_SBY
88	PCIE_CLK_REF+	BIOS_DIS1#
89	PCIE_CLK_REF-	DD0_HPDP
90	GND(FIXED)	GND(FIXED)
91	SPI_POWER	DDIO_PAIR5+
92	SPI_MISO	DDIO_PAIR5-
93	GPO0	DDIO_PAIR6+
94	SPI_CLK	DDIO_PAIR6-
95	SPI_MOSI	DDIO_DDC_AUX_SEL
96	TPM_PP	USB_HOST_PRSNTP
97	TYPE10#	SPI_CS#
98	SER0_TX	DDIO_CTRLCLK_AUX+
99	SER0_RX	DDIO_CTRLDATA_AUX-
100	GND(FIXED)	GND(FIXED)
101	SER1_TX / CAN_TX	FAN_PWMOUT
102	SER1_RX / CAN_RX	FAN_TACHIN
103	LID#	SLEEP#
104	VCC_12V	VCC_12V
105	VCC_12V	VCC_12V
106	VCC_12V	VCC_12V
107	VCC_12V	VCC_12V
108	VCC_12V	VCC_12V
109	VCC_12V	VCC_12V
110	GND(FIXED)	GND(FIXED)

6.5. Display Connectors

6.5.1. JX8: LVDS/eDP Connector

For LVDS panel

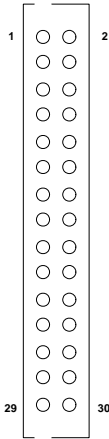

Pin	Signal	Pin	Signal
1	LVDS_A0+	2	Panel_PWR
3	LVDS_A0-	4	Panel_PWR
5	GND	6	Panel_EDID_PWR
7	LVDS_A1+	8	BKLT_PWR
9	LVDS_A1-	10	BKLT_PWR
11	GND	12	GND
13	LVDS_A2+	14	BKLT_CTRL
15	LVDS_A2-	16	BKLT_EN
17	GND	18	GND
19	LVDS_A3+	20	N.C
21	LVDS_A3-	22	LVDS_VDD_EN
23	GND	24	N.C
25	LVDS_A_CLK+	26	LVDS_I2C_DATA
27	LVDS_A_CLK-	28	LVDS_I2C_CLK
29	GND	30	GND

For eDP panel

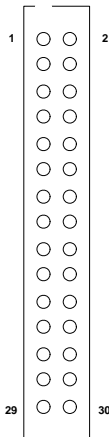

Pin	Signal	Pin	Signal
1	eDP_TX2+	2	Panel_PWR
3	eDP_TX2-	4	Panel_PWR
5	GND	6	N.C
7	eDP_TX1+	8	N.C
9	eDP_TX1-	10	N.C
11	GND	12	N.C
13	eDP_TX0+	14	BKLT_CTRL
15	eDP_TX0-	16	BKLT_EN
17	GND	18	GND
19	N.C	20	N.C
21	N.C	22	N.C
23	GND	24	Hot_Plug
25	eDP_TX3+	26	eDP_AUX-
27	eDP_TX3-	28	eDP_AUX+
29	GND	30	GND

6.5.2. JY2: eDP Backlight Voltage

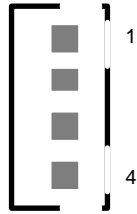

Connector	Status
1-2	GND
2-3	5~12V

6.5.3. JX7: DP

(From DDI0 signal on AB connector)

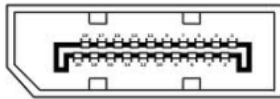

Pin	Signal	Pin	Signal
1	Lane0_P	2	GND
3	Lane0_N	4	Lane1_P
5	GND	6	Lane1_N
7	Lane2_P	8	GND
9	Lane2_N	10	Lane3_P
11	GND	12	Lane3_N
13	CONFIG1 *	14	CONFIG2 *
15	AUX_P	16	GND
17	AUX_N	18	Hot_Plug
19	RTN_PWR	20	PWR

6.6. LVDS Jumper Settings

6.6.1. JP5: Panel Power Voltage

Selects the LVDS Panel Power voltage on JX8

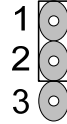

Jumper	Status
1-2	+ 3.3V <<<<
2-3	+ 5.0V

6.6.2. JP6: Backlight Power Voltage

Selects the Backlight Panel Power voltage on JX8

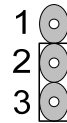

Jumper	Status
1-2	+ 3.3V
2-3	+ 5.0V <<<<

6.6.3. JP3: Brightness Control

Sets the Panel Brightness Control to Voltage Level Or PWM. When set to Voltage Level, the Backlight CTRL signal can be varied from 0-5V in 0.5V increments

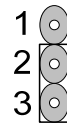

Jumper	Status
1-2	Voltage Level
2-3	PWM <<<<

6.6.4. JP7: Brightness PWM Source

Sets the Panel Brightness PWM Source to GPU or LVDS I2C. When Brightness PWM Source is set to LVDS I2C, the user will be able to use the SEMA command to control the PWM pulse to the panel backlight

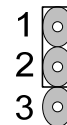

Jumper	Status
1-2	GPU <<<<
2-3	LVDS I2C

6.7. Audio Connectors

6.7.1. JX2: S/PDIF Output Jack (optical)

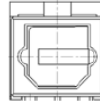

6.7.2. JX6: S/PDIF Output Header



Pin	Signal	Pin	Signal
1	SPDIF - Out	2	GND

6.7.3. JX1: Three-in-One Audio Phone Jack



Color	Signal
Blue	Line-In
Green	Line-Out
Pink	MIC-In

6.8. Mini PCIe and mSATA Connector

6.8.1. J2: Mini-PCIe Connector

Supports Mini-PCIe form factor card
Supports PCIe and USB signals
(from PCIe 0 and USB 4 signals on
AB connector)



Pin	Signal	Pin	Signal
1	WAKE#	2	+ 3.3V
3	N.C	4	GND
5	N.C	6	+ 1.5V
7	CLKREQ#	8	N.C
9	GND	10	N.C
11	REFCLK-	12	N.C
13	REFCLK+	14	N.C
15	GND	16	N.C
17	N.C	18	GND
19	N.C	20	N.C
21	GND	22	PERST#
23	PERn0	24	+ 3.3V
25	PERp0	26	GND
27	GND	28	+ 1.5V
29	GND	30	SMB_CLK
31	PETn0	32	SMB_DATA
33	PETp0	34	GND
35	GND	36	USB_D-
37	GND	38	USB_D+
39	+ 3.3V	40	GND
41	+ 3.3V	42	N.C
43	GND	44	N.C
45	RSVD	46	N.C
47	RSVD	48	+ 1.5V
49	RSVD	50	GND
51	RSVD	52	+ 3.3V

6.8.2. J5: Mini-PCIe/mSATA Connector

Support Mini-PCIe and mSATA form factor
 Support PCIe, USB and SATA signal
 (from PCIe 2, USB 5 and SATA 1 signals
 on AB connector)

For Mini-PCIe

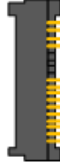

Pin	Signal	Pin	Signal
1	WAKE#	2	+ 3.3V
3	N.C	4	GND
5	N.C	6	+ 1.5V
7	CLKREQ#	8	N.C
9	GND	10	N.C
11	REFCLK-	12	N.C
13	REFCLK+	14	N.C
15	GND	16	N.C
17	N.C	18	GND
19	N.C	20	N.C
21	GND	22	PERST#
23	PERn0	24	+ 3.3V
25	PERp0	26	GND
27	GND	28	+ 1.5V
29	GND	30	SMB_CLK
31	PETn0	32	SMB_DATA
33	PETp0	34	GND
35	GND	36	USB_D-
37	GND	38	USB_D+
39	+ 3.3V	40	GND
41	+ 3.3V	42	N.C
43	PCIe/mSATA_SEL	44	N.C
45	RSVD	46	N.C
47	RSVD	48	+ 1.5V
49	RSVD	50	GND
51	RSVD	52	+ 3.3V

For mSATA



Pin	Signal	Pin	Signal
1	WAKE#	2	+ 3.3V
3	N.C	4	GND
5	N.C	6	+ 1.5V
7	CLKREQ#	8	N.C
9	GND	10	N.C
11	REFCLK-	12	N.C
13	REFCLK+	14	N.C
15	GND	16	N.C
17	N.C	18	GND
19	N.C	20	N.C
21	GND	22	PERST#
23	SATA_RX-	24	+ 3.3V
25	SATA_RX+	26	GND
27	GND	28	+ 1.5V
29	GND	30	SMB_CLK
31	SATA_TX-	32	SMB_DATA
33	SATA_TX+	34	GND
35	GND	36	USB_D-
37	GND	38	USB_D+
39	+ 3.3V	40	GND
41	+ 3.3V	42	N.C
43	PCIe/mSATA_SEL	44	N.C
45	RSVD	46	N.C
47	RSVD	48	+ 1.5V
49	RSVD	50	GND
51	RSVD	52	+ 3.3V

6.8.3. JPX8: Mini-PCIe/mSATA Selection

Select the card type for the J5 connector

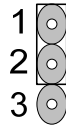

Jumper	Status
1-2	Mini-PCIe <<<<
2-3	mSATA

6.9. SATA

6.9.1. J9: SATA



Pin	Signal
1	GND
2	Tx+
3	Tx-
4	GND
5	Rx-
6	Rx+
7	GND

6.9.2. JX9: Power for SATA



Pin	Signal
1	+ 5.0V
2	GND

6.10. USB and LAN

6.10.1. J10: Mini-USB

Supports Mini-USB form factor
(from USB 7 signals on AB connector)



Pin	Signal
1	Client_PWR_Detect
2	USB-
3	USB+
4	N.C.
5	GND

6.10.2. J13: USB 3.0 x 2

USB 2.0 compatible
(from USB 0, USB_SS0, USB 1,
USB_SS1 signals on AB connector)

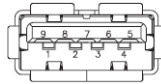

Pin	Signal
1	USB3_P5VA
2	USB2_CMAN
3	USB2_CMAP
4	GND
5	USB3A_CMRXN
6	USB3A_CMRXP
7	GND
8	USB3A_CMTXN
9	USB3A_CMTXP

6.10.3. JX14: USB 2.0 x 2 and GbE RJ-45

USB from USB 2, USB 3, signals on AB connector
GbE from Intel® i210 using PCIe x1 signals
on AB connector)

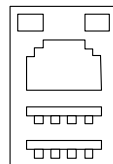

Pin	Signal (USB)
1	+ 5V
2	USB-
3	USB+
4	GND

6.10.4. JX3: GbE RJ-45

From GbE signals on AB connector

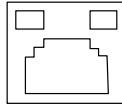

Pin	Signal
1	BI_DA+
2	BI_DA-
3	BI_DB+
4	BI_DC+
5	BI_DC-
6	BI_DB+
7	BI_DD+
8	BI_DD-

6.11. Serial Ports

J3: COM 1
 J6: COM 2
 Only TX/RX support

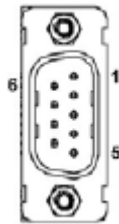

Pin	Signal	Pin	Signal
1	DCD#	2	RXD
3	TXD	4	DTR#
5	GND	6	DSR
7	RTS#	8	CTS#
9	RI#		

6.12. I²C, SMBus and CAN Bus

6.12.1. H2: I2C Bus



Pin	Signal
1	+ 3.3V
2	I2C_DAT
3	I2C_CK
4	GND

6.12.2. H1: SM Bus



Pin	Signal
1	+ 3.3V
2	SMB_DAT
3	SMB_CLK
4	GND

6.12.3. JX10: CAN Bus

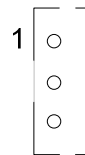

Pin	Signal
1	UART_Tx
2	UART_Rx
3	GND

6.13. Fan Connector

6.13.1. JPX4: Fan Type Selection

Selects 4-pin or 3-pin type fan

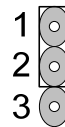

Jumper	Status
1-2	4P FAN <<<<
2-3	3P FAN

6.13.2. JPX5: Fan Control

Only available for 3-pin fan

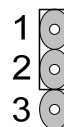

Jumper	Status
1-2	Full ON <<<<
2-3	PWM CTRL

6.13.3. H3: Fan Header

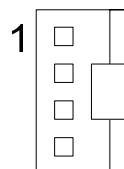

Pin	Signal
1	Speed_Control (PWM)
2	Speed Sense
3	PWR (5V)
4	GND

6.14. Other Connectors

6.14.1. JPX6: EXT GPIO

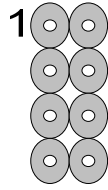

Pin	Signal	Pin	Signal
1	GPI_0	2	GPO_0
3	GPI_1	4	GPO_1
5	GPI_2	6	GPO_2
7	GPI_3	8	GPO_3

6.14.2. JPY1: GPIO

From GPIO signal on AB connector

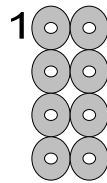

Pin	Signal	Pin	Signal
1	GPI_0	2	GPO_0
3	GPI_1	4	GPO_1
5	GPI_2	6	GPO_2
7	GPI_3	8	GPO_3

6.14.3. J7: SD Card Slot

From SD signal on AB connector

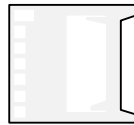

6.14.4. UX4: Secondary SPI BIOS Socket

JPX7: BIOS Selection



Pin	Signal
1	CS#
2	WP#
3	Module BIOS <<<<
4	Carrier BIOS
5	DI
6	CLK
7	HOLD#
8	+ 3.3V

6.14.5. H5: CPLD_JTAG

Pin	Signal
1	CPLD_TCKL
2	GND
3	CPLD_TDO
4	+ 3.3V
5	CPLD_TMS
6	N.C.
7	N.C.
8	N.C.
9	CPLD_TDI
10	GND

6.15. Other Jumpers

6.15.1. JP4: Clear CMOS

To clear CMOS, shut down the power and short pins 2 and 3

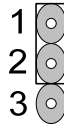

Pin	Signal
1-2	Normal <<<<
2-3	Clear CMOS

6.15.2. JPX7: BIOS Selection

See 7.1 SPI Secondary BIOS for detailed description



Pin	Signal
1-2	Module BIOS <<<<
2-3	Carrier BIOS

6.16. Power Connectors

6.16.1. JX5: AC Adapter

For 19V AC adapter (current: 4.7A)



6.16.2. H4/H7: Smart Battery 1/2 Connectors

Supports dual Smart Batteries



Pin	Signal
1	PWR
2	PWR
3	PWR
4	SMBus_Clk
5	SMBus_Dat
6	Thermistor
7	GND
8	GND
9	GND

6.16.3. JPY2: Smart Battery Configuration

Select 3-cell or 2-cell battery configuration

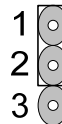

Pin	Signal
1-2	3 Cell <<<<
2-3	2 Cell

6.16.4. JPX1: Protection Selection

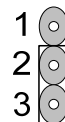

Pin	Signal
1-2	2 Cell
2-3	3 Cell <<<<

6.17. Power Jumper Settings

6.17.1. JPX2: AT/ATX Mode

In AT mode, JPX2 shorts PS_ON# to ground directly to force power on.

Pin	Signal
1-2	ATX <<<<
2-3	AT

6.17.2. JPX3: 5VSB to Module Source

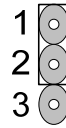

Pin	Signal
1-2	w/ 5VSB <<<<
2-3	w/o 5VSB

6.17.3. JP1: PS_ON# Signal Source

All ADLINK modules support S3 mode and subsequent power down of the ATX power supply. For modules that connect the S3 signal, PS_ON# should always be set to SUS_S3# as source (even when S3 mode is disabled in the BIOS). For modules that do not bring out the S3 signal, PS_ON# should be set to SUS_S5# as source.

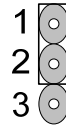

Pin	Signal
1-2	S3 <<<<
2-3	S5

7. Secondary BIOS

The miniBASE-10R supports a secondary BIOS using Serial Peripheral Interface (SPI) for COM.0 Rev. 2.0 modules. Secondary BIOS solutions can be used as an alternative to the on-module BIOS and provide support for the following:

- 1) Testing of new BIOS versions
- 2) Development of firmware modifications
- 3) Recovery if soldered BIOS on module is corrupted

7.1. SPI Secondary BIOS

SPI is supported by PICMG COM.0 Rev. 2.0 to provide a secondary BIOS for COM Express Rev 2.0 modules that support a SPI Secondary BIOS.

To use the BIOS on the module:

- Short pins 1-2 on JPX7

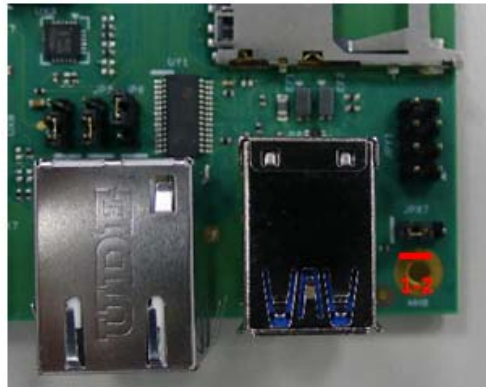

To use the SPI BIOS on the carrier board:

- Short pins 2-3 on JPX7



8. Switches, POST and LEDs

8.1. Switches (S1-S4)

There are four switches on the miniBASE-10R.

- S1 switch is the Reset Button.
- S2 switch is the Power Button.
- S3 switch is the Lid Button. It supports Type 10 modules for ACPI power management behavior setting in OS.
- S4 switch is the Sleep Button. It supports Type 10 modules for ACPI power management behavior setting in OS.

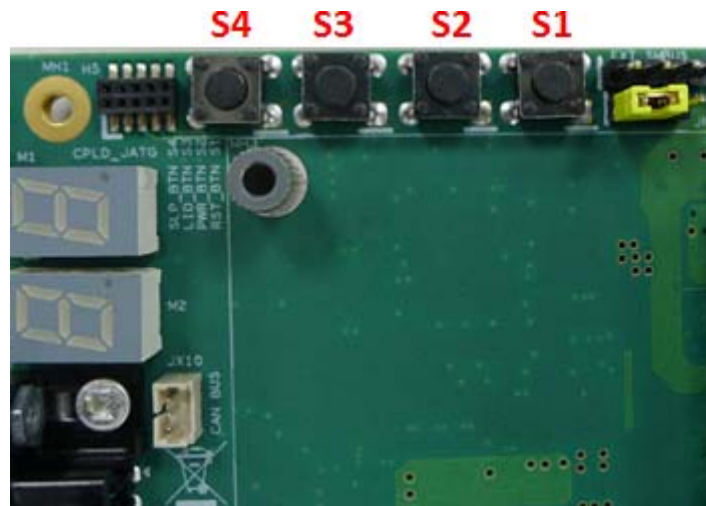

8.2. POST

An LPC based POST display is added for debugging. The two LEDs display the actual POST data.

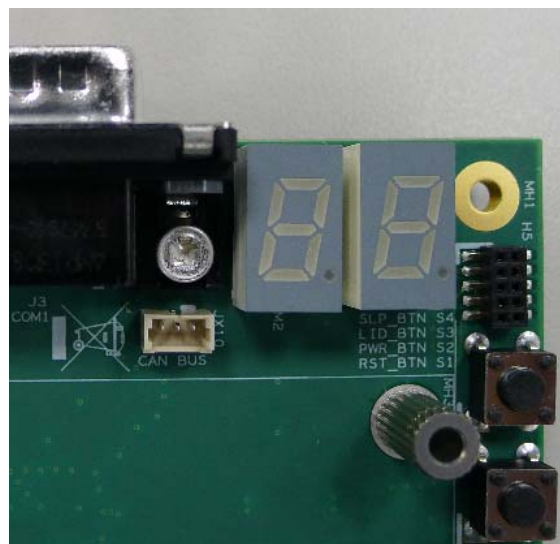

8.3. Indicator LEDs

There are five indicator LEDs as follows:

- LED1 (D1): indicates 3.3V power for carrier board (location: rear side)
- LED2 (D2): indicates 5VSB power for carrier board and COM Express module (location: rear side)
- LED3 (D3): indicates hard drive activity (location: front side)
- LED4 (D4): indicates 5V power for carrier board (location: rear side)
- LED5 (D5): indicates 19VDC power adapter is plugged in (location: front side)

9. Smart Battery Management System

The miniBASE-10R integrates a Smart Battery Management System that supports dual Smart Batteries and a 19V adapter. The adapter connects to miniBASE-10R through a standard 2.5mm input jack. The battery charger output voltage is configurable to adapt it to battery packs consisting of 2 or 3 Li-ion battery cells.*

***Note:** ADLINK Starter Kit battery packs with 2 cells provide 5.7VDC to 8.4VDC output to the COM Express module. The reference battery packs with 3 cells provide 9VDC to 12.6VDC output to the COM Express module. Please ensure that the COM Express module supports **Wide Voltage Input** power.

9.1. Input Power

	AD/DC Adapter Input	Battery*
Voltage	19V	2 cells: 5.7VDC - 8.4VDC 3 cells: 9VDC - 12.6VDC
Max. Current	4.7A	Dependent on battery
Power	90W	n.a.

***Note:** The optional reference battery packs provided with miniBASE-10R have 3 cells in series or 2 cells in series.

9.2. Charger Output Capability

	Charger
Voltage	12.6V (3cell) 8.4V (2cell)
Max. Current	4.0 A

9.3. Key Characteristics

- **Simultaneous Dual Charging:** charges two Smart Batteries simultaneously to reduce charging time
- **Simultaneous Discharging:** simultaneous dual discharge increases battery operating time by reducing internal battery losses due to high discharge rate

9.4. Battery Settings

See 6.16 Power Connectors and 6.17 Power Jumper Settings for detailed information.

9.5. Windows OS Interface

9.5.1. Device Presence

ADLINK COM Express Type 10 modules feature a BIOS that fully supports all Smart Battery communications using existing interfaces defined in the COM Express specification and are fully compatible with the integrated Smart Battery Management System. The BIOS reports the presence of a Smart Battery device to the OS. In Windows, the battery power subsystem information is listed in the Device Manager under the "Batteries" category. The system BIOS will check the current system configuration and then report back to the OS. There are three possibilities for the battery report information.

9.5.2. No Battery Power Subsystem Present

The system BIOS checks for the presence of a charger, selector or system manager. If there is no device attached, it will only report the presence of an AC adapter to the OS.



9.5.3. Battery Present

The system BIOS will report an AC adapter and two battery devices to the OS



9.5.4. Battery State Notification

The system BIOS is notified of the state (AC power or battery mode) when it receives an SMBALERT# as a SCI event. An alert may be sent to update the charging state, remaining battery capacity, or presence of an AC adapter. The OS can also query the system BIOS to update the battery power information. Placing the cursor over the battery state icon will cause the OS to update the battery power information.

When an AC adapter is inserted or removed, the battery state icon in the taskbar will change to indicate the current state. To display the battery state icon in the taskbar, enable the option "Always show icon on the taskbar" from the "Advanced" tab of "Power Options Properties".



9.5.5. Battery Information

To view detailed battery status information, double-click on the battery or AC adapter icon.

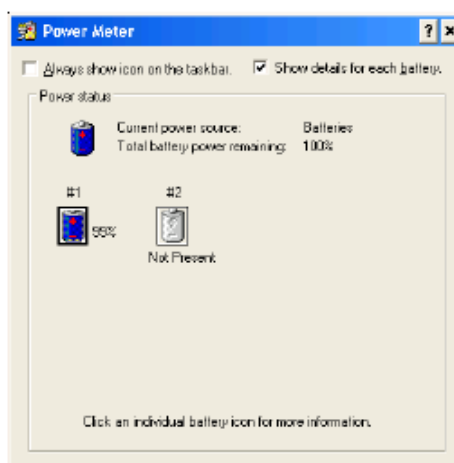

Safety Instructions

Read and follow all instructions marked on the product and in the documentation before you operate your system. Retain all safety and operating instructions for future use.

- Please read these safety instructions carefully.
- Please keep this User's Manual for later reference.
- The equipment should be operated only from the type of power source indicated on the rating label. Make sure the voltage of the power source when connect the equipment to the power outlet.
- If your equipment has a voltage selector switch, make sure that the switch is in the proper position for your area. The voltage selector switch is set at the factory to the correct voltage.
- For pluggable equipment, that the socket-outlet shall be installed near the equipment and shall be easily accessible.
- Place the power cord such a way that people can not step on it. Do not place anything over the power cord.
- If the equipment is not use for long time, disconnect the equipment from mains to avoid being damaged by transient overvoltage.
- All cautions and warnings on the equipment should be noted.
- Please keep this equipment from humidity.
- Do not use this equipment near water or a heat source.
- Lay this equipment on a reliable surface when install. A drop or fall could cause injury.
- Never pour any liquid into opening; this could cause fire or electrical shock.
- Openings in the case are provided for ventilation. Do not block or cover these openings. Make sure you provide adequate space around the system for ventilation when you set up your work area. Never insert objects of any kind into the ventilation openings.
- To avoid electrical shock, always unplug all power cables and modem cables from the wall outlets before removing covers.
- Lithium Battery provided (real time clock battery)

CAUTION: Risk of explosion if battery is replaced with one of an incorrect type. Dispose of used batteries according to the instructions.

- If one of the following situations arises, get the equipment checked by a service personnel:
 - The power cord or plug is damaged.
 - Liquid has penetrated into the equipment.
 - The equipment has been exposed to moisture.
 - The equipment has not work well or you can not get it work according to user's manual.
 - The equipment has dropped and damaged.
 - If the equipment has obvious sign of breakage.

Getting Service

ADLINK Technology, Inc.

Address: 9F, No.166 Jian Yi Road, Zhonghe District
New Taipei City 235, Taiwan
Tel: +886-2-8226-5877
Fax: +886-2-8226-5717
Email: service@adlinktech.com

Ampro ADLINK Technology, Inc.

Address: 5215 Hellyer Avenue, #110, San Jose, CA 95138, USA
Tel: +1-408-360-0200
Toll Free: +1-800-966-5200 (USA only)
Fax: +1-408-360-0222
Email: info@adlinktech.com

ADLINK Technology (China) Co., Ltd.

Address: 300 Fang Chun Rd., Zhangjiang Hi-Tech Park, Pudong New Area
Shanghai, 201203 China
Tel: +86-21-5132-8988
Fax: +86-21-5132-3588
Email: market@adlinktech.com

ADLINK Technology Beijing

Address: Rm. 801, Power Creative E, No. 1, B/D, Shang Di East Rd.
Beijing, 100085 China
Tel: +86-10-5885-8666
Fax: +86-10-5885-8625
Email: market@adlinktech.com

ADLINK Technology Shenzhen

Address: 2F, C Block, Bldg. A1, Cyber-Tech Zone, Gao Xin Ave. Sec. 7, High-Tech Industrial Park S.
Shenzhen, 518054 China
Tel: +86-755-2643-4858
Fax: +86-755-2664-6353
Email: market@adlinktech.com

LIPPERT ADLINK Technology GmbH

Address: Hans-Thoma-Strasse 11, D-68163, Mannheim, Germany
Tel: +49-621-43214-0
Fax: +49-621 43214-30
Email: emea@adlinktech.com

ADLINK Technology, Inc. (French Liaison Office)

Address: 6 allée de Londres, Immeuble Ceylan
91940 Les Ulis, France
Tel: +33 (0) 1 60 12 35 66
Fax: +33 (0) 1 60 12 35 66
Email: france@adlinktech.com

ADLINK Technology Japan Corporation

Address: KANDA374 Bldg. 4F, 3-7-4 Kanda Kajicho, Chiyoda-ku
Tokyo 101-0045, Japan
Tel: +81-3-4455-3722
Fax: +81-3-5209-6013
Email: japan@adlinktech.com

ADLINK Technology, Inc. (Korean Liaison Office)

Address: 802, Mointer B/D, 326 Seocho-daero, Seocho-Gu,
Seoul 137-881, Korea
Tel: +82-2-2057-0565
Fax: +82-2-2057-0563
Email: korea@adlinktech.com

ADLINK Technology Singapore Pte. Ltd.

Address: 84 Genting Lane #07-02A, Cityneon Design Centre
Singapore 349584
Tel: +65-6844-2261
Fax: +65-6844-2263
Email: singapore@adlinktech.com

ADLINK Technology Singapore Pte. Ltd. (Indian Liaison Office)

Address: #50-56, First Floor, Spearhead Towers
Margosa Main Road (between 16th/17th Cross), Malleswaram
Bangalore - 560 055, India
Tel: +91-80-65605817, +91-80-42246107
Fax: +91-80-23464606
Email: india@adlinktech.com

ADLINK Technology, Inc. (Israeli Liaison Office)

Address: 27 Maskit St., Corex Building
PO Box 12777
Herzliya 4673300, Israel
Tel: +972-77-208-0230
Fax: +972-77-208-0230
Email: israel@adlinktech.com

ADLINK Technology, Inc. (UK Liaison Office)

Tel: +44 774 010 59 65
Email: UK@adlinktech.com