

NOTES:

1. ALL DIMENSIONS ARE IN $\frac{\text{INCHES}}{[\text{MILLIMETERS}]}$; $\frac{\text{LBS}}{[\text{GRAMS}]}$

2. DIMENSIONS APPEARING IN TABLE ARE AS FOLLOWS:
 a AS SUPPLIED
 b AFTER UNRESTRICTED RECOVERY

3. COATING (ADHESIVE) IS OPTIONAL. AS SUPPLIED DIMENSIONS APPEARING IN TABLE ARE FOR UNCOATED PARTS. WHEN COATING IS ADDED, ENTRY DIAMETERS WILL BE REDUCED BY .06 MAX.

4. MOLDING PORTS ARE OPTIONAL. WHEN -00 MODIFICATION NUMBER IS SPECIFIED MOLDING PORTS WILL BE LOCATED AS SHOWN.

ON SIZES 222A111 AND 222A121 THE 0.18 INCH DIAMETER MOLDING PORT AT "T" WILL BE ELIMINATED. THE 0.12" DIA MOLDING PORT WILL BE ENLARGED TO 0.18 INCHES

5. WEIGHT SHOWN IN TABLE OF DIMENSIONS IS BASED ON POLYOLEFIN PART

6. ORDERING INFORMATION 222A1XX -XX -XX /XXX /0

BASE PART NUMBER

MATERIAL DASH NUMBER

- 3 POLYOLEFIN, SEMI RIGID (RT-301)
- 4 POLYOLEFIN, FLEXIBLE (RT-1304)
- 5 ELASTOMER, FLEXIBLE (RT-501)
- 6 SILICONE (RT-602)
- 8 POLYOLEFIN, SPACE (RT-1308)
- 12 FLUORO ELASTOMER, FLEXIBLE (RT-1312)
- 25 ELASTOMER, FLUID RESISTANT (RT-1325)
- 100 POLYOLEFIN, SEMI-FLEXIBLE ZEROHAL (RT-1323)

MODIFICATION NUMBER

ADHESIVE SLASH NUMBER

SEE COMPATIBILITY CHART BELOW

COLOR DESIGNATOR

IF THIS DOCUMENT IS PRINTED IT BECOMES UNCONTROLLED. CHECK FOR THE LATEST REVISION.

COMPATIBILITY CHART

MATERIAL DASH NO.	ADHESIVE (COATING) SLASH NO.	ADHESIVE (COATING) S NO.
-3; -4	/42; /86	S-1017; S-1048;
-5	/42	S-1017
-6; -8; -12	NOT APPLICABLE	N/A
-25	/42; /86; /225	S-1017; S-1048; S-1206
-100	/86; /180; /184	S-1017; S-1030

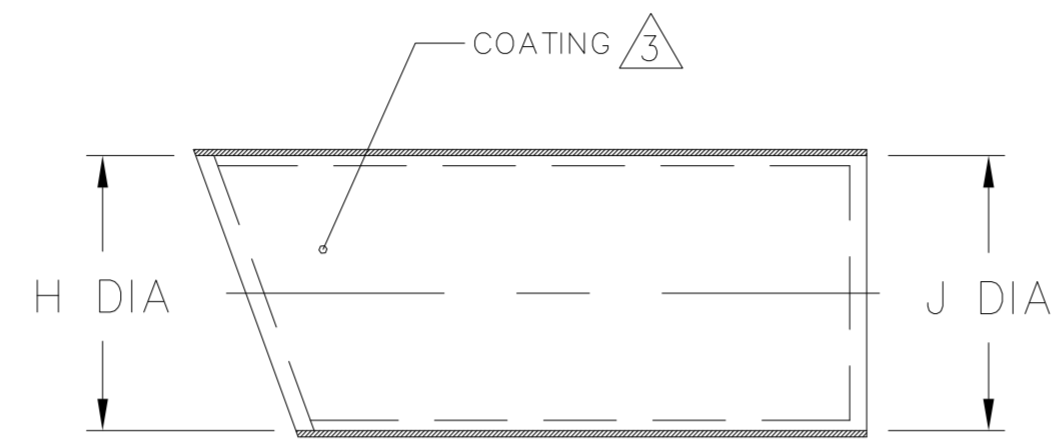

AS SUPPLIED



AFTER UNRESTRICTED RECOVERY

REVISIONS		
LTR	DESCRIPTION	DATE
U1	REVISED PER ECO-11-005139	29MAR11

TABLE OF DIMENSIONS

PART DESCRIPTION	H			J				P	R	S	T	U	JO	W	C°		WEIGHT REF
	MIN -3,-4,-5,-6 -12,-25,-100 a	MIN -8 a	MAX b	MIN -3,-4 -6,-25 a	MIN -5,-8 -100 a	MIN -12 a	MAX b	±10% b	±10% b	±10% b	±10% b	±10% b	±10% b	±20% b	±10% a	±5% b	b
222A111	.70 [17,8]	.43 [10,9]	.31 [7,9]	.70 [17,8]	.43 [10,9]	.39 [9,9]	.15 [3,8]	.68 [17,3]	.79 [20,1]	.61 [15,5]	N/A	.45 [11,4]	.17 [4,3]	.04 [1,02]	180	90	.002 [0,91]
222A121	.98 [24,9]	.63 [16,0]	.40 [10,2]	.98 [24,9]	.63 [16,0]	.71 [18,0]	.21 [5,3]	.84 [21,3]	.89 [22,6]	.65 [16,5]	N/A	.58 [14,7]	.23 [5,8]	.05 [1,3]	180	90	.003 [1,36]
222A132	1.18 [30,0]	.83 [21,1]	.56 [14,2]	1.18 [30,0]	.83 [21,1]	.81 [20,6]	.25 [6,4]	1.06 [26,9]	1.05 [26,7]	.73 [18,5]	.75 [19,1]	.70 [17,8]	.28 [7,1]	.06 [1,5]	180	90	.006 [2,72]
222A142	1.28 [32,5]	.90 [22,9]	.68 [17,3]	1.28 [32,5]	.90 [22,9]	.90 [22,9]	.27 [6,9]	1.44 [36,6]	1.20 [30,5]	.81 [20,6]	.75 [19,1]	.98 [24,9]	.40 [10,2]	.07 [1,8]	180	90	.014 [6,35]
222A152	1.42 [36,1]	1.08 [27,4]	.86 [21,8]	1.42 [36,1]	1.08 [27,4]	1.04 [26,4]	.33 [8,4]	1.72 [43,7]	1.38 [35,1]	.90 [22,9]	.75 [19,1]	1.18 [30,0]	.50 [12,7]	.07 [1,8]	180	90	.019 [8,62]
222A163	1.73 [43,9]	1.12 [28,4]	1.08 [27,4]	1.73 [43,9]	1.12 [28,4]	1.08 [27,4]	.37 [9,4]	2.11 [53,6]	1.73 [43,9]	1.15 [29,2]	.75 [19,1]	1.34 [34,0]	.68 [17,3]	.08 [2,0]	180	90	.029 [13,15]
222A174	2.09 [53,1]	1.90 [48,3]	1.33 [33,8]	2.09 [53,1]	1.90 [48,3]	1.84 [46,7]	.59 [15,0]	2.98 [75,7]	2.08 [52,8]	1.34 [34,0]	1.00 [25,4]	2.10 [53,3]	1.26 [32,0]	.13 [3,3]	180	90	.077 [34,93]
222A185	2.66 [67,6]	2.30 [58,4]	1.74 [44,2]	2.66 [67,6]	2.30 [58,4]	2.14 [54,4]	.80 [20,3]	3.84 [97,5]	2.60 [66,0]	1.66 [42,2]	1.00 [25,4]	2.80 [71,1]	1.60 [40,6]	.15 [3,8]	180	90	.143 [64,86]
222A196	3.45 [87,6]	2.71 [68,8]	2.18 [55,4]	3.45 [87,6]	2.71 [68,8]	2.48 [63,0]	.92 [23,4]	5.04 [128,0]	3.12 [79,2]	1.93 [49,0]	1.00 [25,4]	3.45 [87,6]	2.22 [56,4]	.18 [4,6]	180	90	.310 [140,6]

CUSTOMER DRAWING

UNLESS OTHERWISE SPECIFIED DIMENSIONS ARE INCHES. METRIC DIMENSIONS ARE IN BRACKETS.
 DECIMAL TOLERANCES
 .XXX ± 0.005 [0.13 mm]
 .XX ± 0.01 [0.25 mm]
 .X ± 0.1 [0.50 mm]
 ANGLE TOLERANCE
 .X ± 1 DEG.
 TE CONNECTIVITY RESERVES THE RIGHT TO AMEND THIS DRAWING AT ANY TIME. USERS SHOULD EVALUATE THE SUITABILITY OF THE PRODUCT FOR THEIR APPLICATION.
 © 2004, 2011 Tyco Electronics Corporation, a TE Connectivity Ltd. company. All rights reserved.

DRAWN
YUNGUYEN
 APPROVED
DHURRELL
 THIRD ANGLE PROJECTION

TE TE Connectivity Raychem Molded Parts
 305 Constitution Dr
 Menlo Park, CA 94025

TITLE
BOOT, 90 DEGREE,
THIN WALL
 SIZE B CODE IDENT. NO. 06090 DWG. NO. 222A111thru196
 DO NOT SCALE THIS DRAWING SHEET 1 OF 1

Mouser Electronics

Authorized Distributor

Click to View Pricing, Inventory, Delivery & Lifecycle Information:

TE Connectivity:

[222A132-25-0](#) [222A132-3-0](#) [222A111-3-0](#) [222A142-3/42-0](#) [222A152-3-0](#) [222A142-3-00-0](#) [222A142-12-0](#)
[222A111-3/42-0](#) [222A121-25-0](#) [222A111-4-0](#) [222A121-3/42-0](#) [222A121-4-0](#) [222A132-25/86-0](#) [222A132-3/42-0](#)
[222A132-4/42-0](#) [222A152-100-0](#) [222A152-25/86-0](#) [222A152-25-0](#) [222A163-3/42-0](#) [222A163-3-0](#) [222A163-4-0](#)
[222A121-25/86](#) [222A174-4/86-0](#) [222A111-3/86-0](#) [222A121-3/86-0](#) [222A111-25-0](#) [222A121-3-0](#) [222A142-25-0](#)
[222A142-3-0](#) [222A163-3-0-CS5501](#)