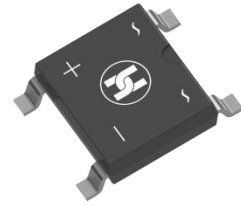
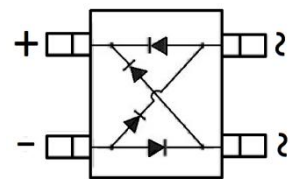


**BRIDGE RECTIFIER**
**FEATURES**

- Low Reverse voltage leakage current
- Glass Passivated Die Construction
- Low Forward Voltage Drop
- High forward surge current capability
- Small Surface Mount device


**ABS**

**MECHANICAL DATA**

- Case: ABS
- Case Material: Molded Plastic. UL flammability
- Classification Rating: 94V-0
- Moisture Sensitivity: Level 1 per J-STD-020
- Weight: 0.10 grams (approximate)

**MAXIMUM RATINGS (T<sub>A</sub> = 25°C unless otherwise noted)**

Parameter	Symbol	Value	Unit
Repetitive peak reverse voltage	V <sub>RRM</sub>	1000	V
DC Reverse Voltage	V <sub>R</sub>	1000	V
RMS Reverse Voltage	V <sub>RMS</sub>	700	V
Mean rectifying current	I <sub>F</sub>	0.5/0.8	A
Non-Repetitive Peak Forward Surge Current @ t = 8.3 ms	I <sub>FSM</sub>	30	A
Thermal Resistance From Junction To Ambient	R <sub>θJA</sub>	80	°C/W
Junction Temperature	T <sub>J</sub>	-55 ~+150	°C
Storage Temperature	T <sub>STG</sub>	-55 ~+150	°C

Note1: On glass-epoxy P.C.B I<sub>F</sub>=0.5A, On aluminum substrate I<sub>F</sub>=0.8A

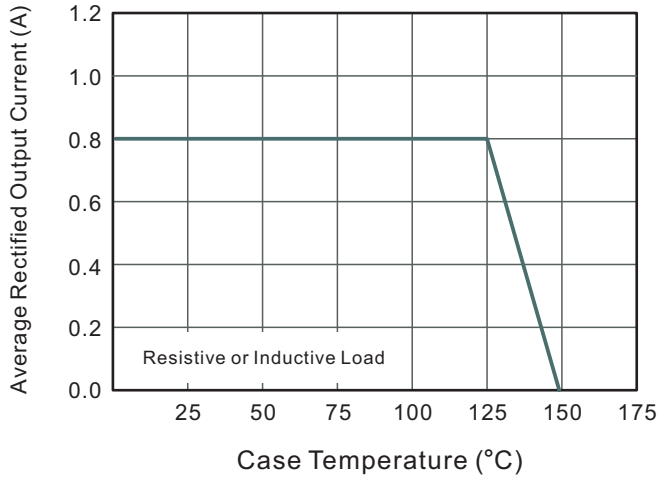
**ELECTRICAL CHARACTERISTICS (T<sub>A</sub> = 25°C unless otherwise specified)**

Parameter	Symbol	Min	Max	Unit	Conditions
Forward voltage	V <sub>F</sub>		1.0	V	I <sub>F</sub> =0.4A
Forward voltage	V <sub>F</sub>		1.1	V	I <sub>F</sub> =0.8A
Reverse current T=25°C	I <sub>R</sub>		5	uA	V <sub>R</sub> =1000V
Reverse current T=125°C	I <sub>R</sub>		100	uA	V <sub>R</sub> =1000V
Junction capacitance	C <sub>J</sub>		13	pF	V=4V <sub>DC</sub> , f=1MH

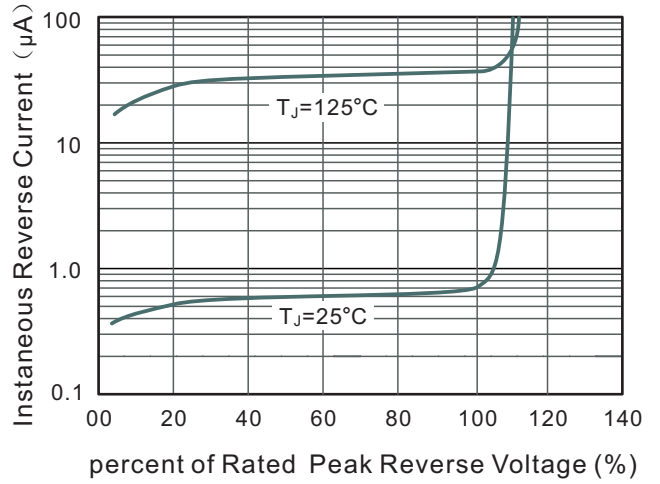
**BRIDGE RECTIFIER**

**Typical Characteristics**

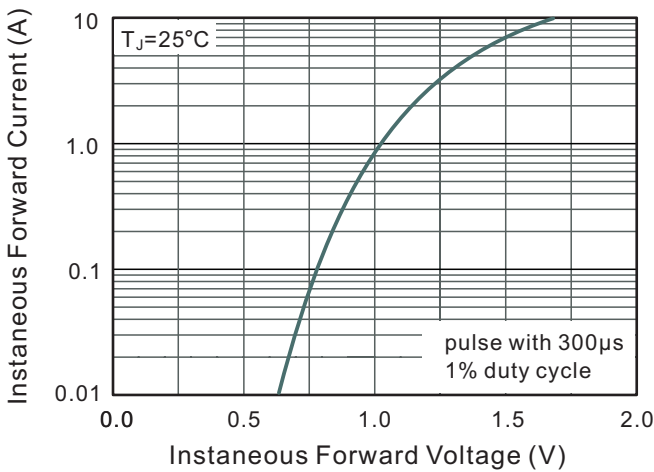
**Fig.1 Average Rectified Output Current Derating Curve**



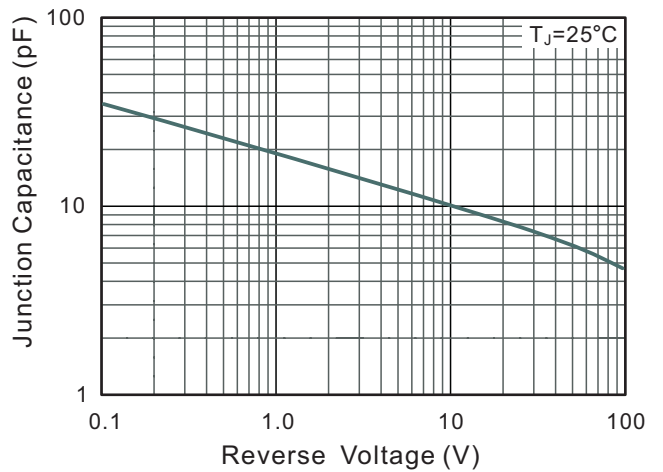
**Fig.2 Typical Reverse Characteristics**



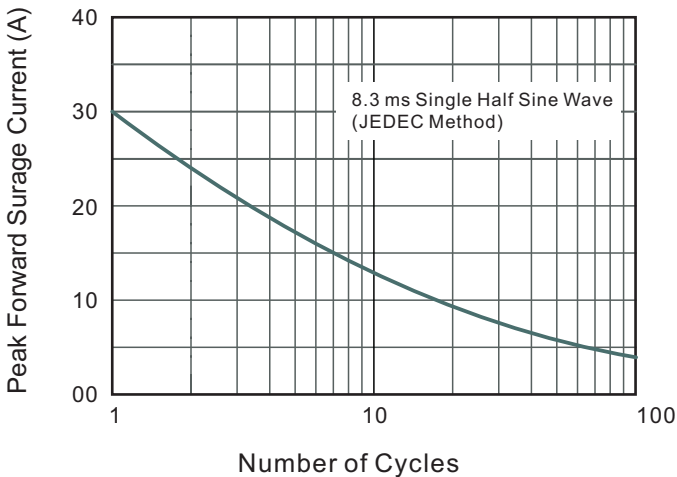
**Fig.3 Typical Instantaneous Forward Characteristics**

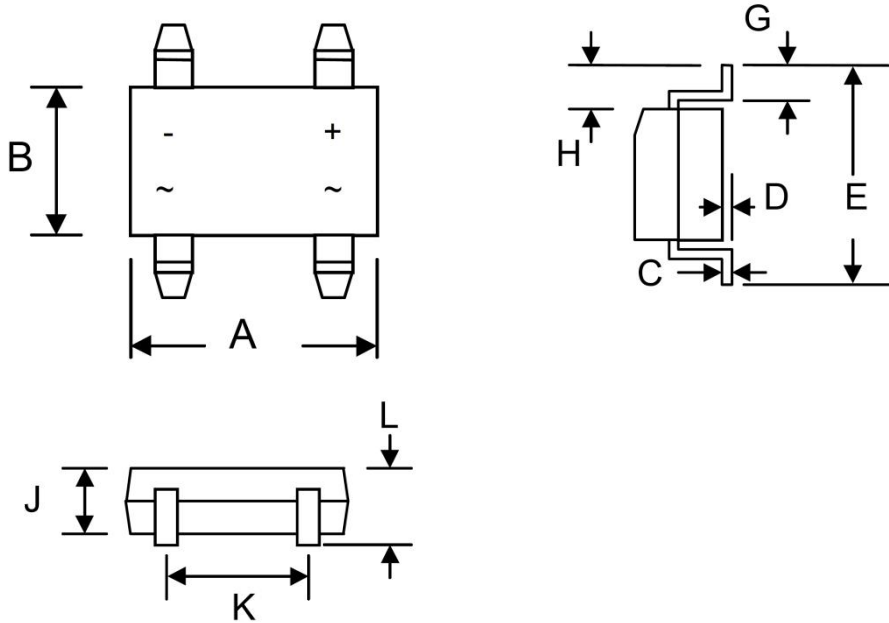


**Fig.4 Typical Junction Capacitance**

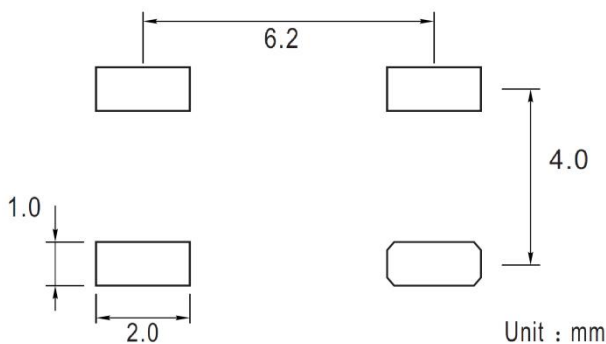


**Fig.5 Maximum Non-Repetitive Peak Forward Surge Current**

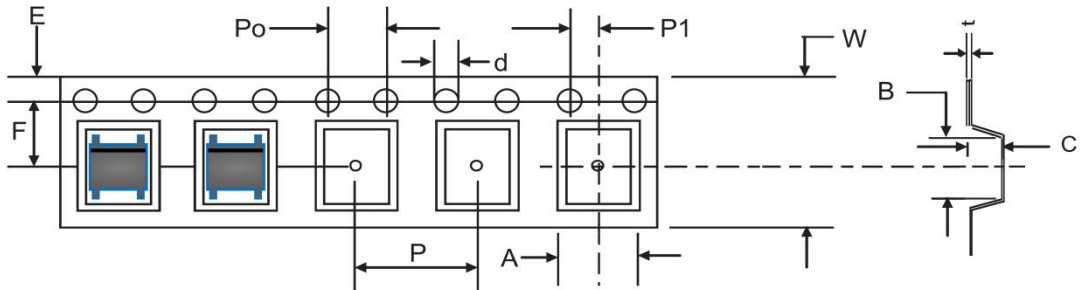


**BRIDGE RECTIFIER**
**ABS Package Outline Dimensions**


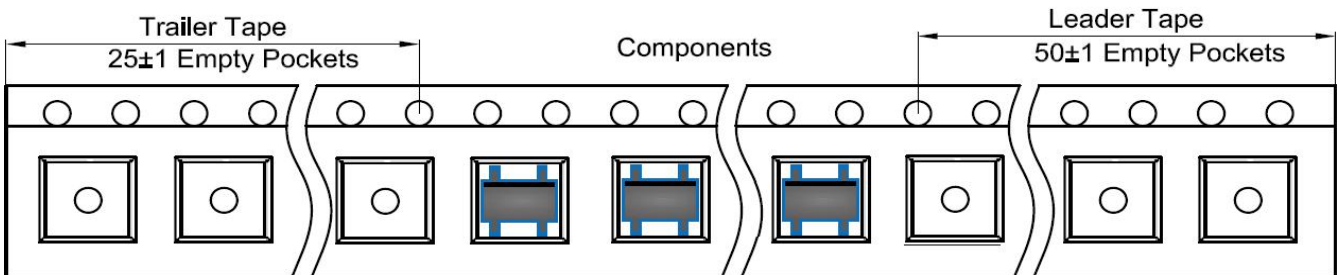
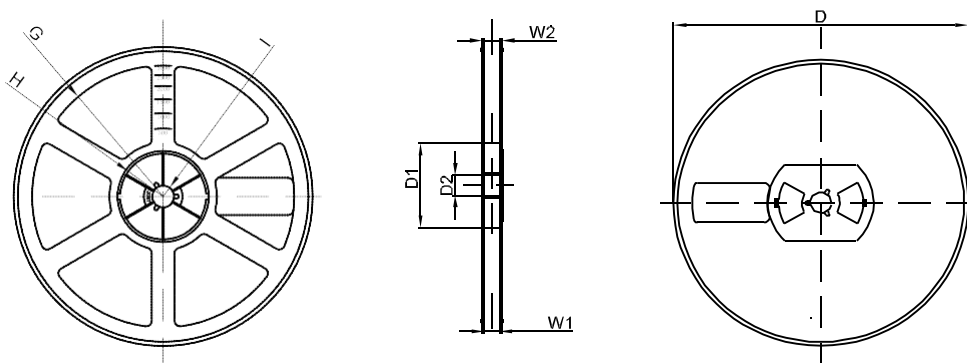
Symbol	Dimensions In Millimeters		Dimensions In Inches	
	Min.	Max.	Min.	Max.
A	4.80	5.30	0.189	0.209
B	4.20	4.60	0.165	0.181
C	0.15	0.25	0.006	0.010
D	-----	0.20	—	0.008
E	6.00	6.80	0.236	0.268
G	0.30	0.70	0.012	0.028
H	0.90	1.10	0.035	0.043
J	—	1.50	—	0.059
K	3.80	4.20	0.150	0.165
L	1.22	1.72	0.048	0.068

**ABS Suggested Pad Layout**

**Note:**

1. Controlling dimension: in millimeters
2. General tolerance:  $\pm 0.05\text{mm}$
3. The pad layout is for reference purposes only

**BRIDGE RECTIFIER**
**ABS Tape and Reel**
**ABS Embossed Carrier Tape**


DIMENSIONS ARE IN MILLIMETER										
TYPE	A	B	C	d	E	F	P0	P	P1	W
ABS	5.31	6.68	1.85	Ø1.50	1.75	5.50	4.00	8.00	2.00	12.00
TOLERANCE	±0.1	±0.1	±0.1	±0.1	±0.1	±0.1	±0.1	±0.1	±0.1	±0.1

**ABS Tape Leader and Trailer**

**ABS Reel**


DIMENSIONS ARE IN MILLIMETER								
REEL OPTION	D	D1	D2	G	H	I	W1	W2
13" DIA	Ø330	75.0	13.00	R165	R37.50	R6.50	12.40	17.60
TOLERANCE	±2	±1	±1	±1	±1	±1	±1	±1