

REVISION RECORD				
REV	ECN	DESCRIPTION	DRFT	DATE

NOTES1:

UL Standard

1. Rated voltage/current : 300V / 15A
2. Withstanding voltage : AC1600V/1Min.
3. Torque value : M2.5 , 3.54Lb.in
4. Wire range : 22~12AWG

IEC Standard

1. Pollution degree	2
Overvoltage category	III
Rate impulse voltage(KV)	4.0KV
Rate voltage(V)	250V
Rate current(A)	22A

2. Torque value : M2.5 , 0.4N·m
3. Wire range : 0.5~2.5mm²

NOTES2:

1. Dimension shall be interpreted per ASME Y14.5-2009
2. Pitch : 5.0mm, Poles : N=02~12P
3. Stripping length : 6~7mm
4. Operating temperature: -40°C~+105°C
5. Undimensioned tolerances:

Pitch range in mm	Nominal dimension range in mm						0.1/10	
	Over 6 TO 10	Over 10 TO 24	Over 30 TO 60	Over 60 TO 100	Over 100 TO 150	Over 150		
±0.15	±0.20	±0.30	±0.30	±0.50	±0.70	±1.00	±1.30	±2'

6. RoHS Compliance

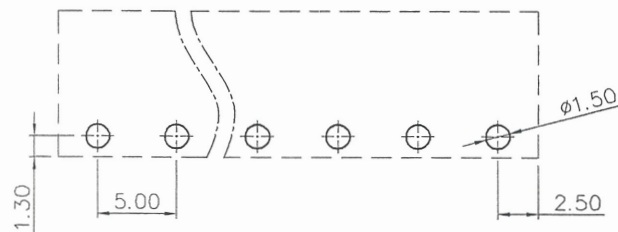
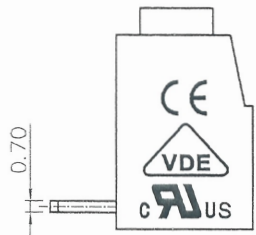
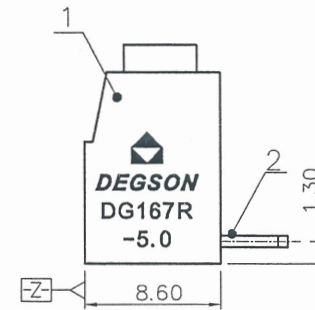
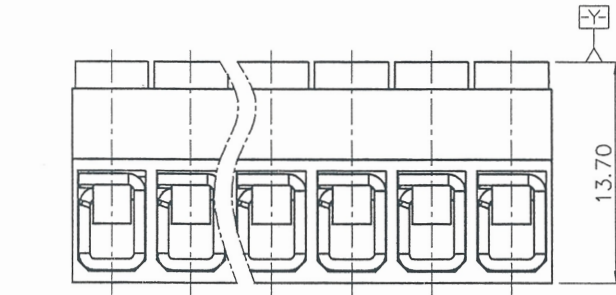
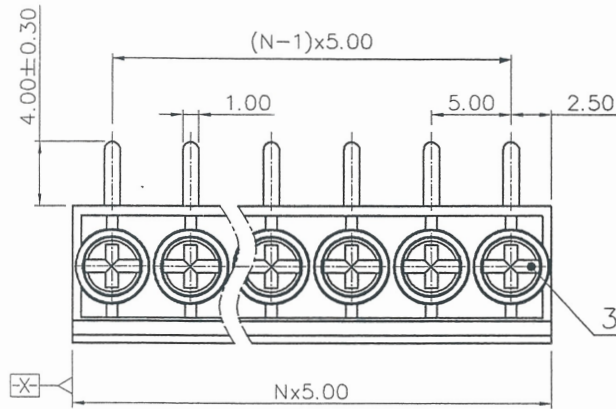

DG167R - 5.0 - XXP - 1Y - 02A (H)
 (Series No.) (Pitch) (Poles) (Single Pitch) (Color): 1.(Grey) 2.(Blue) 3.(Black) 4.(Green) 5.(Orange)
 (RoHS)
 02A-(Customer Request)
 6.(Red) 7.(Transparent) 8.(Yellow) 9.(White)

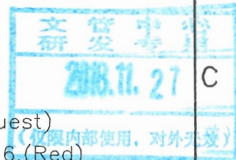

PCB LAYOUT

ITEM	NAME OF PART	MATERIAL	NOTES
3	Screw	Steel	M2.5/Zn Plated
2	Pin	Copper Alloy	M2.5/Sn Plated
1	Housing	PA66	UL94V-0

PART NO.: /		宁波高松电子有限公司 NINGBO DEGSON ELECTRICAL CO., LTD		
APPD: <i>Agon 2018.11.8</i>		NAME: DG167R-5.0-XXP-1Y-02A(H)		
CHKD: <i>Ag. 2 2018.11.8</i>		TITLE: CUSTOMER DRAWING		
DRFT: LJH 2009.04.13		REV	TO	
THIRD ANGLE PROJECTION		DRAWING NO.: DG167R-5.0-C04		SHEET 1/1
		MM (INCH)	DO NOT SCALE DRAWING	SCALE 1:1