

Specification

(Reference)

Title: FIXED THICK FILM CHIP RESISTORS; RECTANGULAR TYPE

Style: RMC1/32,1/20,1/16S,1/16,1/10,1/8,1/4,1/2,1

RoHS COMPLIANCE ITEM

Product specification contained in this specification
are subject to change at any time without notice
If you have any questions or a Purchasing Specification for any quality
Agreement is necessary, please contact our sales staff.



釜屋電機株式會社
KAMAYA ELECTRIC CO., LTD.

Issue Dept.: Research & Development Department Hokkaido Research Center

1. Scope

1.1 This specification covers the detail requirements for fixed thick film chip resistors; rectangular type, style of RMC1/32, 1/20, 1/16S, 1/16, 1/10, 1/8, 1/4, 1/2, 1.

1.2 Applicable documents

- JIS C 5201-1: 1998, JIS C 5201-8: 1998, JIS C 5201-8-1: 1998
- IEC60115-1: 1999, IEC60115-8: 1989 Amendment 1: 1992, IEC60115-8-1: 1989
- EIAJ RC-2134B-2002

2. Classification

Type designation shall be the following form.

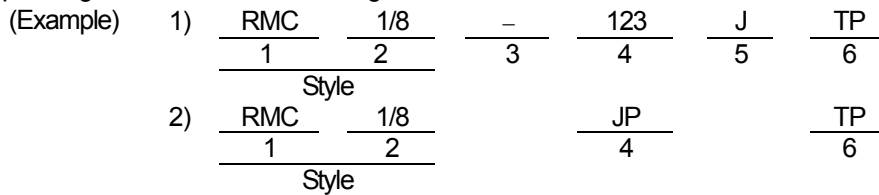

- 1 Fixed thick film chip resistors; rectangular type Style
- 2 Rated dissipation and / or dimension
- 3 Temperature coefficient of resistance

K	±100×10 ⁻⁶ /°C
-(Dash)	Standard

- 4 Rated resistance Example; 123 → 12kΩ, Chip jumper: JP
- 5 Tolerance on rated resistance
- 6 Packaging form

3. Rating

3.1 The ratings shall be in accordance with Table-1.

Table-1(1)

Style	Rated dissipation (W)	Temperature coefficient of resistance (10 ⁻⁶ / °C)		Rated resistance range (Ω)	Preferred number series for resistors	Tolerance on rated resistance
RMC1/32	0.03	Standard	±200	100~1M	E24	F(±1%) J(±5%)
			±300	10~91		
			+600~-200	4.7~9.1		
RMC1/20	0.05	Standard	±200	10~10M	E24, 96	F(±1%)
			+350~-100	4.02~9.76		
			+600~-200	1~3.92		
			±200	10~1M	E24	G(±2%) J(±5%)
			±200	10~10M		
			+350~-100	4.3~9.1		
			+600~-200	1~3.9		
			+1000~+300	0.47~0.91		
RMC1/16S	0.1	K	±100	10~1M	E24, 96	F(±1%)
			±200	1.02M~10M		
		Standard	+500~-200	1~9.76	E24	G(±2%) J(±5%)
			±200	10~10M		
			±200	10~10M		
			+500~-200	1~9.1		

Table-1(2)

Style	Rated dissipation (W)	Temperature coefficient of resistance (10 ⁶ / °C)		Rated resistance range (Ω)	Preferred number series for resistors	Tolerance on rated resistance
		K	±100			
RMC1/16	0.1	K	±100	10~10M	E24, 96	F(±1%)
		Standard	+500~-200	1~9.76		
			±200	10~10M		
			+500~-200	1.0~9.1		
			±200	10~22M		
		+500~-200	1.0~9.1	E24	J(±5%)	
+1000~+300	0.47~0.91	K(±10%)				
RMC1/10	0.125	K	±100	10~2.2M	E24,96	F(±1%)
		Standard	+200	2.21M~10M		
			+500~-200	1.0~9.76		
			±200	10~10M		
			+500~-200	1.0~9.1		
		±200	10~22M	E24	J(±5%)	
+500~-200	1.0~9.1	K(±10%)				
+1000~+300	0.27~0.91					
RMC1/8	0.25	K	±100	10~1M	E24,96	F(±1%)
		Standard	+200	1.02M~10M		
			+500~-200	1.0~9.76		
			±200	10~10M		
			+500~-200	1.0~9.1		
		±200	10~24M	E24	J(±5%)	
+500~-200	1.0~9.1	K(±10%)				
+1000~+300	0.22~0.91					
RMC1/4	0.5	K	±100	10~1M	E24,96	F(±1%)
		Standard	+200	1.02M~10M		
			+500~-200	1.0~9.76		
			±200	10~1M		
			±200	10~22M		
		+500~-200	1.0~9.1	E24	J(±5%)	
+1000~+300	0.2~0.91	K(±10%)				
RMC1/2	0.75		K	±100	10~1M	E24, 96
		Standard	+500~-200	1.0~9.76	E24	
			±200	10~1M		
			±200	10~22M		
			+500~-200	1.0~9.1		
		+1000~+300	0.33~0.91	E24	J(±5%)	
Standard	±200	10~1M	E24			G(±2%)
	±200	10~22M				
RMC1	1.0	K	±100	10~1M	E24, 96	F(±1%)
		Standard	+500~-200	1.0~9.76		
			±200	10~1M		
			±200	10~22M		
			+500~-200	1.0~9.1		
		+1000~+300	0.33~0.91	E24	J(±5%)	
Standard	±200	10~1M	E24			G(±2%)
	±200	10~22M				
+500~-200	1.0~9.1	E24	J(±5%)			
+1000~+300	0.33~0.91			E24	K(±10%)	

Table-1(3)

Style	Limiting element voltage (V)	Isolation voltage (V)	Category temperature range (°C)
RMC1/32	15	50	-55~+125
RMC1/20	25		
RMC1/16S	50	100	-55~+155
RMC1/16			
RMC1/10	200	500	
RMC1/8			
RMC1/4			
RMC1/2			
RMC1			

Note. Rated current of chip jumper: RMC1/32: 0.5(A), RMC1/20, 1/16S: 1(A),
RMC1/16, 1/10, 1/8, 1/4, 1/2,1: 2(A)

Note. Resistance value of chip jumper: 50 mΩ max.

3.2 Climatic category

3.2.1 RMC1/32,1/20

55/125/56 Lower category temperature - 55 °C
Upper category temperature +125 °C
Duration of the damp heat, steady state test 56days

3.2.2 RMC1/16S,1/16,1/10,1/8,1/4,1/2,1

55/155/56 Lower category temperature - 55 °C
Upper category temperature +155 °C
Duration of the damp heat, steady state test 56days

3.3 Stability class

5% Limits for change of resistance:
-for long-term tests ±(5%+0.1Ω) Chip jumper: 50 mΩ max.
-for short-term tests ±(1%+0.05Ω) Chip jumper: 50 mΩ max.

3.4 Derating

The derated values of dissipation (or current rating in case of chip jumper) at temperature in excess of 70 °C shall be as indicated by the following curve.

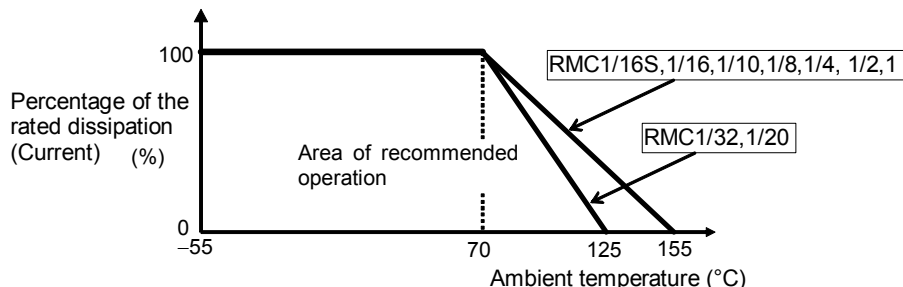

Figure-1 Derating curve

3.5 Rated voltage

d. c. or a. c. r. m. s. voltage calculated from the square root of the product of the rated resistance and the rated dissipation.

$$E = \sqrt{P \cdot R}$$

E : Rated voltage (V)
P : Rated dissipation (W)
R : Rated resistance (Ω)

Limiting element voltage can only be applied to resistors when the resistance value is equal to or higher than the critical resistance value.

At high value of resistance, the rated voltage may not be applicable.

4. Packaging form

The standard packaging form shall be in accordance with Table-2.

Table-2

Symbol	Packaging form		Standard packaging quantity / units	Application
B	Bulk (loose package)		1,000 pcs.	RMC1/32,1/20,1/16S,1/16,1/10,1/8,1/4,1/2,1
BA	Bulk case		5,000 pcs.	RMC1/8
			10,000 pcs.	RMC1/10
			25,000 pcs.	RMC1/16
PA	Press pocket taping (paper taping)	8mm width, 2mm pitches	20,000 pcs.	RMC1/32
			15,000 pcs.	RMC1/20
TH	Paper taping	8mm width, 2mm pitches	10,000 pcs.	RMC1/16S,1/16
TP	Paper taping	8mm width, 4mm pitches	5,000 pcs.	RMC1/16, 1/10, 1/8
TE	Embossed taping	8mm width, 4mm pitches	4,000 pcs.	RMC1/4
		12mm width, 4mm pitches		RMC1/2, 1

5. Dimensions

5.1 The resistor shall be of the design and physical dimensions in accordance with Figure-2 and Table-3.

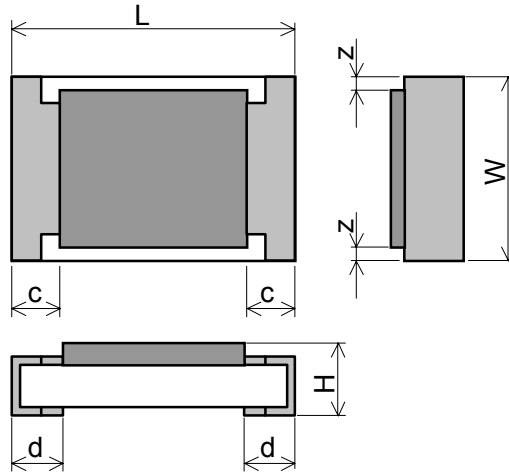

Figure-2

Table-3

Unit : mm

• Bulk, Taping

Style	Country of origin	L	W	H	c	d	z
RMC1/32	Japan, Malaysia	0.4±0.02	0.2±0.02	0.13±0.02	0.08±0.03	0.1±0.03	-----
RMC1/20	Japan, Malaysia	0.6±0.03	0.3±0.03	0.23±0.03	0.1±0.05	0.15±0.05	
RMC1/16S	Malaysia, China	1.0±0.05	0.5±0.05	0.35±0.05	0.2±0.1	0.25 ^{+0.05} _{-0.10}	
RMC1/16	Malaysia, China	1.6±0.1	0.8 ^{+0.15} _{-0.05}	0.45±0.10	0.3±0.1	0.3±0.1	
RMC1/10	Malaysia, China	2.0±0.1	1.25±0.10	0.55±0.10	0.4±0.2	0.4±0.2	
RMC1/8	Malaysia,	3.2±0.15	1.6±0.15	0.55±0.10	0.5±0.25	0.5±0.25	0.05~0.3
	China	3.1±0.1	1.6±0.1	0.6±0.15	0.45±0.20	0.5±0.2	0~0.1
RMC1/4	Malaysia	3.2±0.15	2.5±0.15	0.55±0.15	0.5±0.25	0.5±0.25	0.05~0.3
RMC1/2	Malaysia	5.0±0.15	2.5±0.15	0.55±0.15	0.6±0.2	0.6±0.2	0.05~0.35
RMC1	Malaysia	6.3±0.15	3.2±0.15	0.55±0.15	0.6±0.2	0.6±0.2	0.05~0.35

• Bulk case

Style	Country of origin	L	W	H	c	d	z
RMC1/16	Malaysia	1.6 ^{+0.10} _{-0.05}	0.8 ^{+0.1} ₀	0.4 ^{+0.08} ₀	0.25 ± 0.10	0.3 ± 0.1	-----
RMC1/10	Malaysia	2.0 ± 0.1	1.25 ± 0.10	0.5 ^{+0.1} ₀	0.4 ± 0.2	0.4 ± 0.2	
RMC1/8	Malaysia	3.1 ± 0.1	1.55 ^{+0.10} _{-0.05}	0.5 ^{+0.1} ₀	0.5 ± 0.25	0.5 ± 0.25	0.05 ~ 0.03

5.2 Net weight (Reference)

Style	Net weight(mg)
RMC1/32	0.035
RMC1/20	0.16
RMC1/16S	0.6
RMC1/16	2
RMC1/10	5
RMC1/8	9
RMC1/4	16
RMC1/2	25
RMC1	40

6. Marking

The Rated resistance of RMC1/32, 1/20, 1/16S should not be marked.

6.1 RMC1/10,1/8,1/4,1/2,1

The nominal resistance shall be marked in 3 digits or 4 digits and marked on over coat side.

- Malaysia products: E24 series: 3 digits, E96 series: 4 digits

In case of the resistance value that E96 overlaps with E24, It is marked by either.

- China products(RMC1/10,1/8): J(±5%): 3 digits, F(±1%): 4 digits

Marking example		Contents	Application
Malaysia	China		
123	123	$12 \times 10^3 [\Omega] \rightarrow 12 [k\Omega]$	RMC1/10,1/8,1/4,1/2,1
2R2	2R2	2.2 $[\Omega]$	Less than 10 Ω of RMC1/8,1/4,1/2,1
2.2	2R2	2.2 $[\Omega]$	Less than 10 Ω of RMC1/10
5623	5623	$562 \times 10^3 [\Omega] \rightarrow 562 [k\Omega]$	RMC1/10,1/8,1/4,1/2,1
12R7	12R7	12.7 $[\Omega]$	RMC1/10,1/8,1/4,1/2,1

6.2 RMC1/16

The nominal resistance shall be marked in 3 digits (E24 and/or E96) and marked on over coat side.

No marking in the E96 series of a Malaysia.

In case of the resistance value that E96 overlaps with E24, there is a case to mark in E96.

Marking example		Contents	Application
Malaysia	China		
123	123	$12 \times 10^3 [\Omega] \rightarrow 12 [k\Omega]$	E24
2R2	2R2	2.2 $[\Omega]$	E24
No marking	02C	$102 \times 10^2 [\Omega] \rightarrow 10.2 [k\Omega]$	E96
No marking	51X	$332 \times 10^{-1} [\Omega] \rightarrow 33.2 [\Omega]$	E96

6.2.1 Symbol for E96 series of resistance value

E96	Symbol	E96	Symbol	E96	Symbol	E96	Symbol	E96	Symbol
100	01	162	21	261	41	422	61	681	81
102	02	165	22	267	42	432	62	698	82
105	03	169	23	274	43	442	63	715	83
107	04	174	24	280	44	453	64	732	84
110	05	178	25	287	45	464	65	750	85
113	06	182	26	294	46	475	66	768	86
115	07	187	27	301	47	487	67	787	87
118	08	191	28	309	48	499	68	806	88
121	09	196	29	316	49	511	69	825	89
124	10	200	30	324	50	523	70	845	90
127	11	205	31	332	51	536	71	866	91
130	12	210	32	340	52	549	72	887	92
133	13	215	33	348	53	562	73	909	93
137	14	221	34	357	54	576	74	931	94
140	15	226	35	365	55	590	75	953	95
143	16	232	36	374	56	604	76	976	96
147	17	237	37	388	57	619	77		
150	18	243	38	392	58	634	78		
154	19	249	39	402	59	649	79		
158	20	255	40	412	60	665	80		

6.2.2 Symbol of multipliers

Symbol	Y	X	A	B	C	D	E	F
Multipliers	10 ⁻²	10 ⁻¹	10 ⁰	10 ¹	10 ²	10 ³	10 ⁴	10 ⁵

6.3 Marking example of Jumper Chip

Marking example		Contents	Application
Malaysia	China		
○ or 000	000	JP	RMC1/16
○			RMC1/10,1/8
000			RMC1/4,1/2,1

7. Performance

7.1 The standard condition for tests shall be in accordance with Sub-clause 4.2, JIS C 5201-1: 1998.

7.2 The performance shall be satisfied in Table-4.

Table-4(1)

No.	Test items	Condition of test (JIS C 5201-1)	Performance requirements
1	Visual examination	Sub-clause 4.4.1 Checked by visual examination.	As in 4.4.1 The marking shall be legible, as checked by visual examination.
2	Dimension Resistance	Sub-clause 4.4.2 Sub-clause 4.5	As specified in Table-3 of this specification. As in 4.5.2 The resistance value shall correspond with the rated resistance taking into account the specified tolerance. Chip jumper: 50mΩ max.
3	Voltage proof	Sub-clause 4.7 Method: 4.6.1.4(See Figure-5) Test voltage: Alternating voltage with a peak value of 1.42 times the insulation voltage. Duration: 60 s ± 5 s Insulation resistance Test voltage: Insulation voltage Duration: 1 min.	No breakdown or flash over R ≥ 1 GΩ
4	Solderability	Sub-clause 4.17 Without ageing Flux: The resistors shall be immersed in a non-activated soldering flux for 2s. Bath temperature: 235 °C ± 5 °C Immersion time: 2 s ± 0.5 s	As in 4.17.4.5 The terminations shall be covered with a smooth and bright solder coating.

Table-4(2)

No	Test items	Condition of test (JIS C 5201-1)	Performance requirements
5	Mounting Overload (in the mounted state) Solvent resistance of the marking	Sub-clause 4.31 Substrate material: Epoxide woven glass Test substrate: Figure-3 Sub-clause 4.13 The applied voltage shall be 2.5 times the rated voltage or twice the limiting element voltage, whichever is the less severe. Duration: 2 s Visual examination Resistance Sub-clause 4.30 Solvent: 2-propanol Solvent temperature: 23 °C ± 5 °C Method 1 Rubbing material: cotton wool Without recovery	No visible damage $\Delta R \leq \pm (1\%+0.05\Omega)$ Chip jumper: 50mΩ max. Legible marking
6	Mounting Bound strength of the end face plating Final measurements	Sub-clause 4.31 Substrate material: Epoxide woven glass Test substrate: Figure-4 Sub-clause 4.33 Bent value: 3 mm (3225 size max.) 1 mm (5025 siz min.) Resistance Sub-clause 4.33.6 Visual examination	$\Delta R \leq \pm (1\%+0.05\Omega)$ Chip jumper: 50mΩ max. No visible damage
7	Resistance to soldering heat Component solvent resistance	Sub-clause 4.18 Solder temperature: 260 °C ± 5 °C Immersion time: 10 s ± 0.5 s Visual examination Resistance Sub-clause 4.29 Solvent: 2-propanol Solvent temperature: 23 °C ± 5 °C Method 2 Recovery: 48 h Visual examination Resistance	As in 4.18.3.4 No sign of damage such as cracks. $\Delta R \leq \pm (1\%+0.05\Omega)$ Chip jumper: 50mΩ max. No visible damage $\Delta R \leq \pm (1\%+0.05\Omega)$ Chip jumper: 50mΩ max.

Table-4(3)

No	Test items	Condition of test (JIS C 5201-1)	Performance requirements
8	Mounting Adhesion Rapid change temperature	Sub-clause 4.31 Substrate material: Epoxide woven glass Test substrate: Figure-3 Sub-clause 4.32 Force: 5 N (RMC1/32: 2N, RMC1/20: 3N) Duration: 10 s ± 1 s Visual examination Sub-clause 4.19 RMC1/32,1/20 Lower category temperature: -55 °C Upper category temperature: +125 °C RMC1/16S,1/16,1/10,1/8,1/4,1/2,1 Lower category temperature: -55 °C Upper category temperature: +155 °C Duration of exposure at each temperature: 30 min. Number of cycles: 5 cycles. Visual examination Resistance	No visible damage No visible damage $\Delta R \leq \pm(1\%+0.05\Omega)$ Chip jumper: 50mΩ max.
9	Climatic sequence -Dry heat -Damp heat, cycle (12+12hour cycle) First cycle -Cold -Damp heat, cycle (12+12hour cycle) Remaining cycle -D.C. load	Sub-clause 4.23 Sub-clause 4.23.2 RMC1/32,1/20 Test temperature: +125 °C RMC1/16S,1/16,1/10,1/8,1/4,1/2,1: Test temperature: +155 °C Duration: 16 h Sub-clause 4.23.3 Test method: 2 Test temperature: 55 °C [Severity(2)] Sub-clause 4.23.4 Test temperature -55 °C Duration: 2h Sub-clause 4.23.6 Test method: 2 Test temperature: 55 °C [Severity (2)] Number of cycles: 5 cycles Sub-clause 4.23.7 The applied voltage shall be the rated voltage or the limiting element voltage whichever is the smaller. Duration: 1 min. Visual examination Resistance	No visible damage $\Delta R \leq \pm (5\%+0.1\Omega)$ Chip jumper: 50mΩ max.

Table-4(4)

No	Test items	Condition of test (JIS C 5201-1)	Performance requirements
10	Mounting Endurance at 70 °C	Sub-clause 4.31 Substrate material: Epoxide woven glass (RMC1 may use Alumina substrate.) Test substrate: Figure-3 Sub-clause 4.25.1 Ambient temperature: 70 °C ± 2 °C Duration: 1000 h The voltage shall be applied in cycles of 1.5 h on and 0.5 h off. The applied voltage shall be the rated voltage or the limiting element voltage whichever is the smaller. Examination at 48 h , 500 h and 1000 h: Visual examination Resistance	No visible damage $\Delta R \leq \pm (5\%+0.1\Omega)$ Chip jumper: 50m Ω max.
11	Mounting Variation of resistance with temperature	Sub-clause 4.31 Substrate material: Epoxide woven glass Test substrate: Figure-3 Sub-clause 4.8 RMC1/32,1/20: -55 °C / +20 °C +20 °C / +125°C RMC1/16S,1/16,1/10,1/8,1/4,1/2,1: -55 °C / +20 °C +20 °C / +155°C	As in Table-1
12	Mounting Damp heat, steady state	Sub-clause 4.31 Substrate material: Epoxide woven glass Test substrate: Figure-3 Sub-clause 4.24 Ambient temperature: 40 °C ± 2 °C Relative humidity : 93 \pm ₃ % a) 1st group: without voltage applied. b) 2nd group: The d. c. voltage shall be applied continuously. The voltage shall be accordance with Sub-clause 4.24.2.1 b). without polarizing voltage [4.24.2.1, c)] Visual examination Resistance	No visible damage Legible marking $\Delta R \leq \pm (5\%+0.1\Omega)$ Chip jumper: 50m Ω max.

Table-4(5)

No	Test items	Condition of test (JIS C 5201-1)	Performance requirements
13	Dimensions (detail) Mounting Endurance at upper category temperature	Sub-clause 4.4.3 Sub-clause 4.31 Substrate material: Epoxide woven glass Test substrate: Figure-3 Sub-clause 4.25.3 RMC1/32,1/20: Ambient temperature:125 °C ± 2 °C RMC1/16S,1/16,1/10,1/8,1/4,1/2,1: Ambient temperature:155 °C ± 2 °C Duration: 1000 h Examination at 48 h, 500 h and 1000 h: Visual examination Resistance	As in Table-3 No visible damage $\Delta R \leq \pm (5\%+0.1\Omega)$ Chip jumper: 50m Ω max.

8. Test substrate

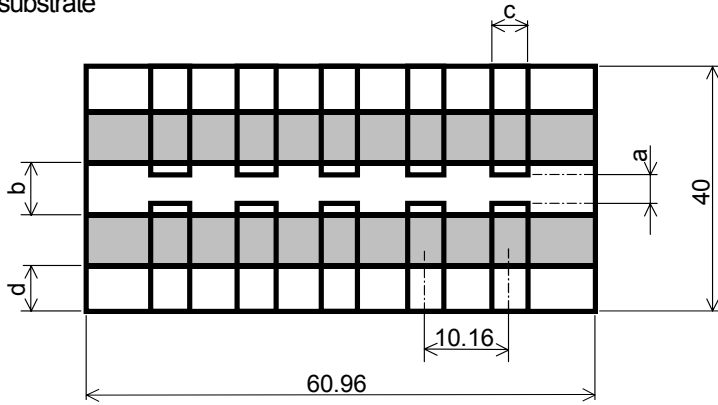

RMC1/2, 1 TEST SUBSTRATE

Unit: mm

□ :Copper clad
■ :Solder resist

Style	a	b	c	d
RMC1/2	4.0	7.5	2.0	7.5
RMC 1	5.0	9.0	4.5	7.5

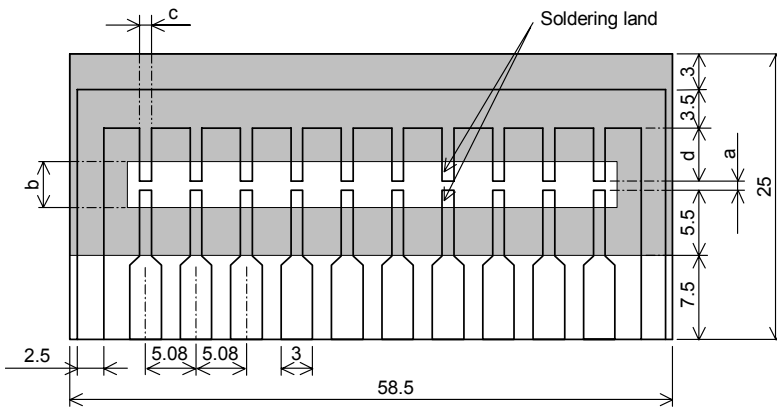

RMC1/20, 1/16S, 1/16, 1/10 1/4 TEST SUBSTRATE

Unit: mm

□ :Copper clad
■ :Solder resist

Style	a	b	c	d
RMC1/32	0.2	0.56	0.2	5.3
RMC1/20	0.3	1.5	0.45	5.2
RMC1/16S	0.6	1.9	0.7	4.9
RMC1/16	1.0	3.6	1.0	4.5
RMC1/10	1.2	4.0	1.5	4.3
RMC1/4	2.2	5.0	2.9	3.3

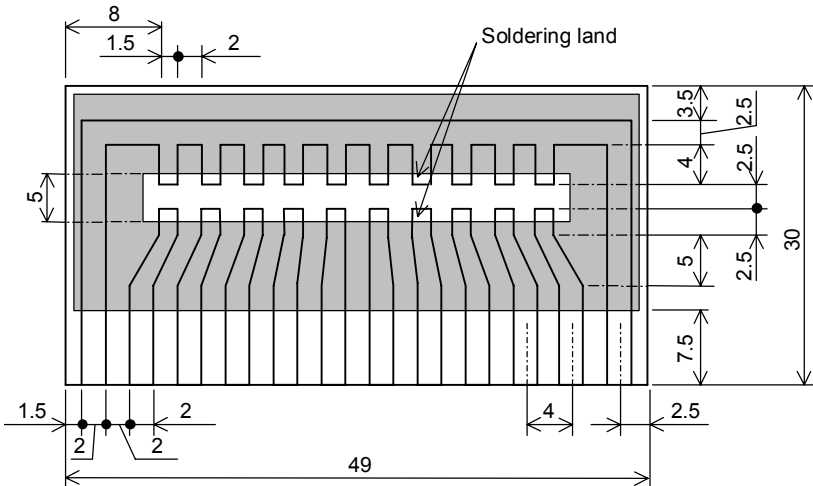

RMC1/8 TEST SUBSTRATE

Unit: mm

□ :Copper clad
■ :Solder resist

Figure-3

- Remark 1). Material: Epoxide woven glass
Thickness: 1.6mm Thickness of copper clad: 0.035mm
- 2). In the case of connection by connector, the connecting terminals are gold plated.
However, the plating is not necessary when the connection is made by soldering.

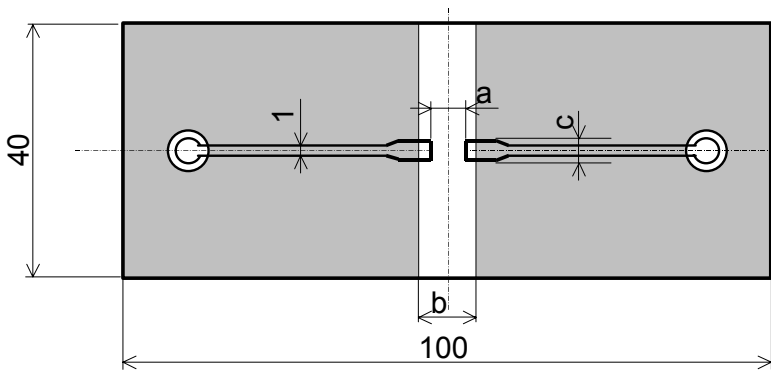

Unit: mm

- :Copper clad
- :Solder resist

Style	a	b	c
RMC1/2	4.0	7.5	3.0
RMC 1	5.0	9.0	4.0

RMC1/2, 1 TERMINAL STRENGTH TEST SUBSTRATE

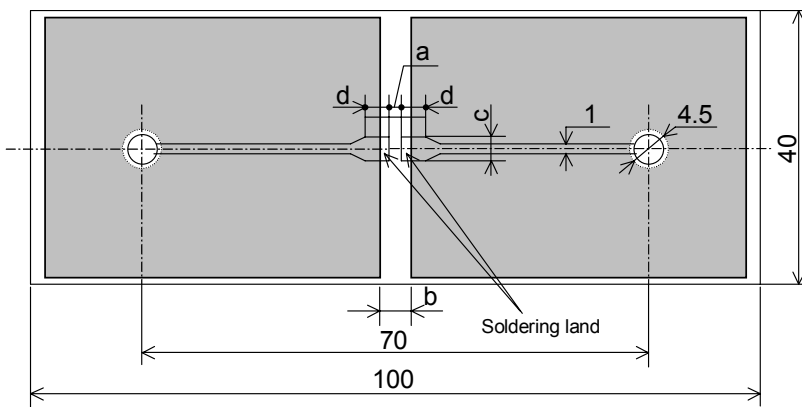

Unit: mm

- :Copper clad
- :Solder resist

Style	a	b	c	d
RMC1/20	0.3	1.1	0.45	2.15
RMC1/16S	0.6	1.9	0.7	2.0
RMC1/16	1.0	3.6	1.20	3.0
RMC1/10	1.2	4.0	1.65	3.0
RMC1/8	2.5	5.0	2.0	2.5
RMC1/4	2.2	5.0	2.9	2.5

RMC1/20,1/16S,1/16,1/10,1/8,1/4 BOUND STRENGTH OF THE END FACE PLATING TEST SUBSTRATE

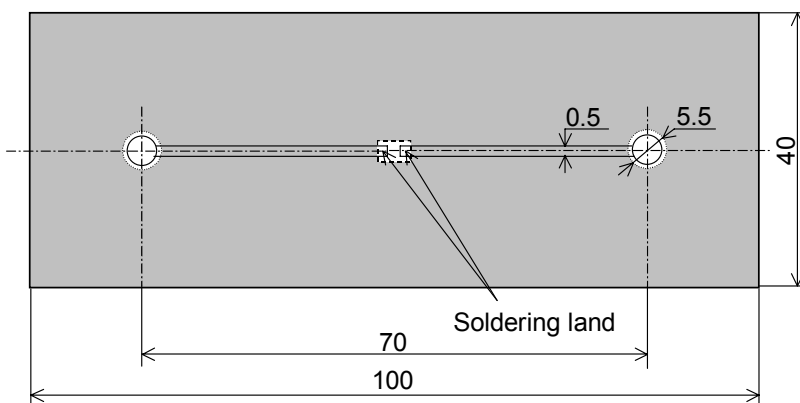

Unit: mm

- :Copper clad
- :Solder resist

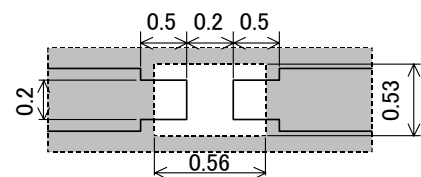

Remark 1). Material: Epoxide woven glass

Thickness: 1.6mm Thickness of copper clad: 0.035mm

RMC1/32 BOUND STRENGTH OF THE END FACE PLATING TEST SUBSTRATE

Figure-4

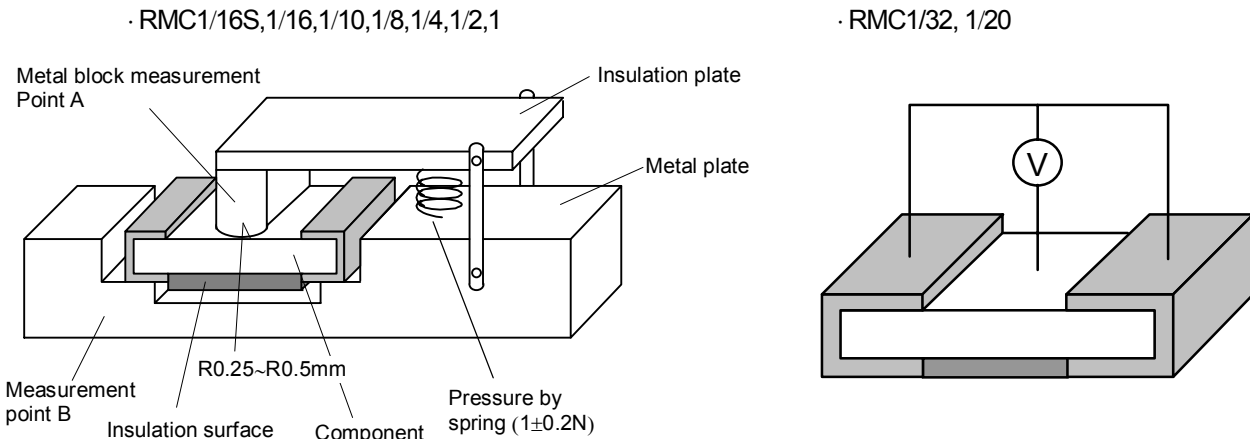

Figure-5

9. Design and dimensions of bulk case

9.1 Applicable documents JIS C 0806-6:2006

9.2 The bulk case shall be of the design and physical dimensions in accordance with Figure-6.

Application: RMC1/16, 1/10, 1/8

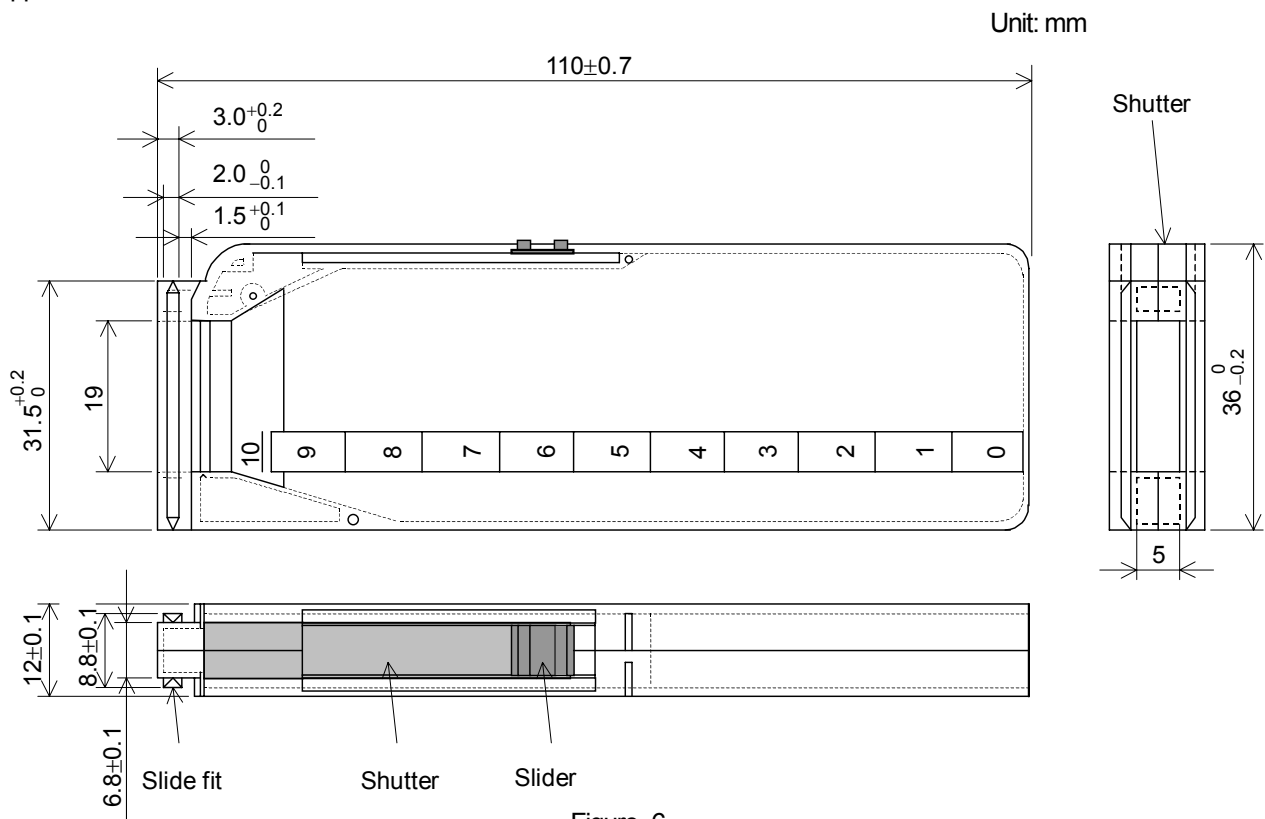

Figure-6

10. Taping

10.1 Applicable documents JIS C 0806-3: 1999, EIAJ ET-7103: 2004, EIAJ ET-7200B: 2003

10.2 Taping dimensions

10.2.1 Press pocket taping (Paper taping, 8mm width, 2mm pitches)

Taping dimensions shall be in accordance with Figure-7 and Table-5.

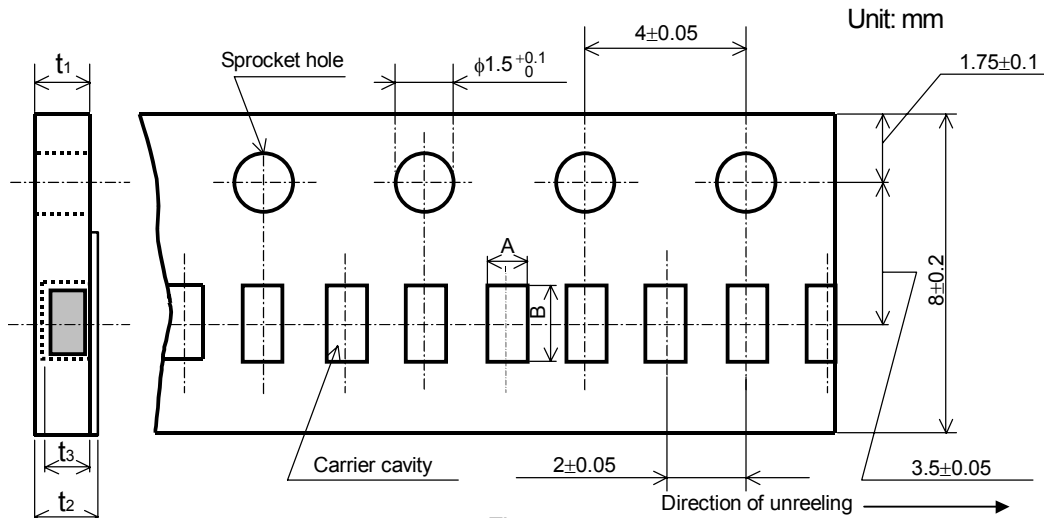

Figure-7

Table-5

Style	A	B	t ₁	t ₂	t ₃
RMC1/32	0.24±0.03	0.45±0.03	0.31±0.03	0.36±0.02	0.15±0.02
RMC1/20	0.37±0.05	0.67±0.05	0.42±0.03	0.45±0.05	0.27±0.02

10.2.2 Paper taping (8mm width, 2mm pitches)

Taping dimensions shall be in accordance with Figure-8 and Table-6.

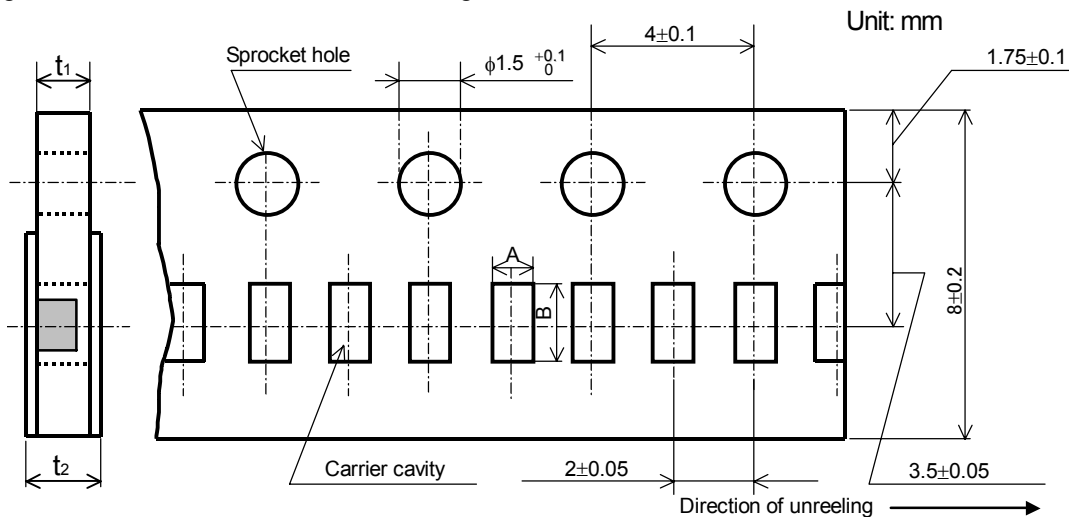

Figure-8

Table-6

Style	A	B	t ₁	t ₂
RMC1/16S	0.65 ^{+0.05} / _{-0.10}	1.15 ^{+0.05} / _{-0.10}	0.4 ± 0.05	0.5max.
RMC1/16	1.15 ± 0.15	1.9 ± 0.2	0.6 ± 0.1	0.8max.

10.2.3 Paper taping (8mm width, 4mm pitches)

Taping dimensions shall be in accordance with Figure-9 and Table-7.

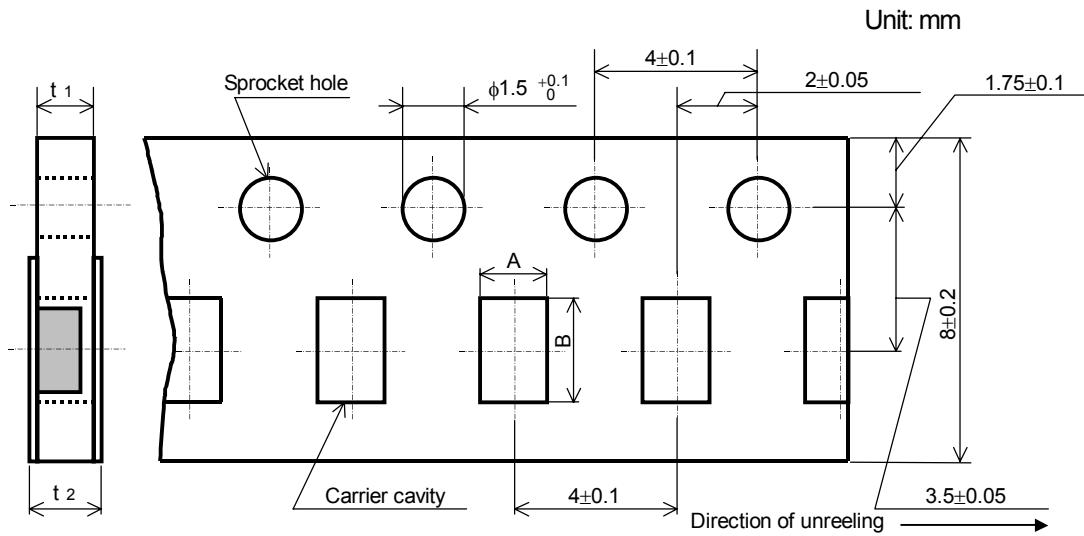

Figure-9

Table-7

Unit: mm

Style	A	B	t ₁	t ₂
RMC1/16	1.15±0.15	1.9±0.2	0.6±0.1	0.8max.
RMC1/10	1.65±0.15	2.5±0.2	0.8±0.1	1.0max.
RMC1/8	2.00±0.15	3.6±0.2		

10.2.4 Embossed taping dimensions shall be in accordance with Figure-10 and Table-8.

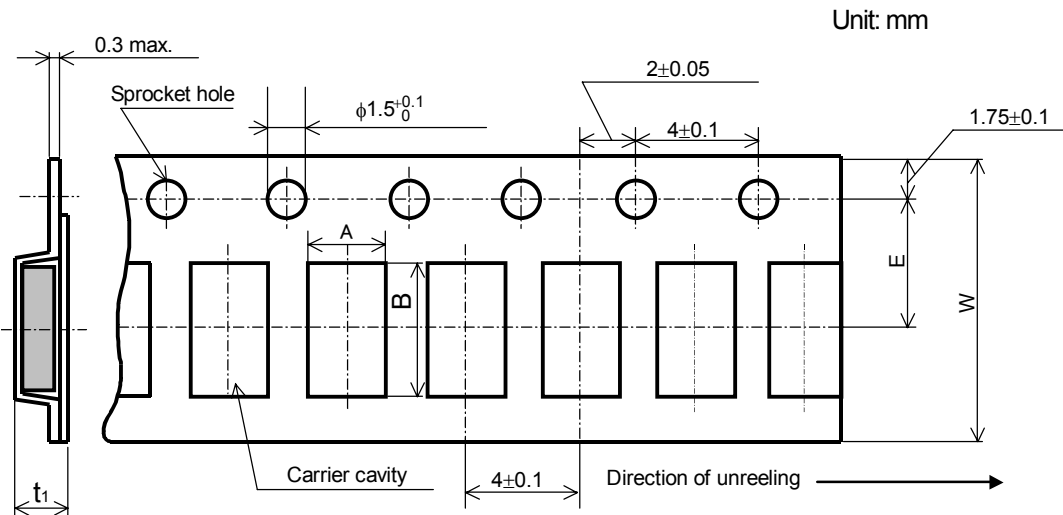

Figure-10

Table-8

Unit: mm

Style	A	B	W	E	t ₁
RMC1/4	2.85±0.20	3.5±0.2	8.0±0.3	3.5±0.05	1.0±0.2
RMC1/2	3.1±0.2	5.5±0.2	12.0±0.3	5.5±0.05	1.1±0.15
RMC 1	3.6±0.2	6.9±0.2			

- 1). The cover tapes shall not cover the sprocket holes.
- 2). Tapes in adjacent layers shall not stick together in the packing.
- 3). Components shall not stick to the carrier tape or to the cover tape.
- 4). Pitch tolerance over any 10 pitches $\pm 0.2\text{mm}$.
- 5). The peel strength of the top cover tape shall be with in 0.1N to 0.5N on the test method as shown in the following RMC1/32,1/20: Figure-11, RMC1/16S, 1/16, 1/10, 1/8: Figure-12, RMC1/4, 1/2, 1: Figure-13.
- 6). When the tape is bent with the minimum radius for RMC1/32, 1/20, 1/16S, 1/16, 1/10,1/8, 1/4: 25 mm, or RMC1/2, 1: 30 mm, the tape shall not be damaged and the components shall maintain their position and orientation in the tape.
- 7). In no case shall there be two or more consecutive components missing.
The maximum number of missing components shall be one or 0.1%, whichever is greater.
- 8). The resistors shall be faced to upward at the over coating side in the carrier cavity.

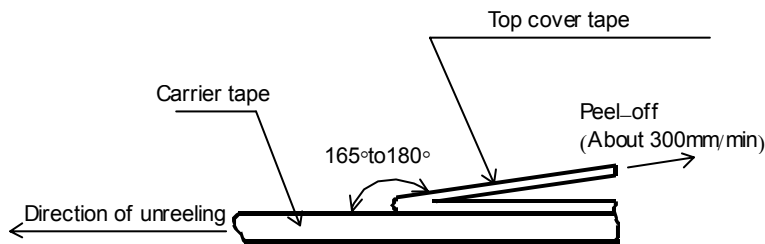

Figure-11

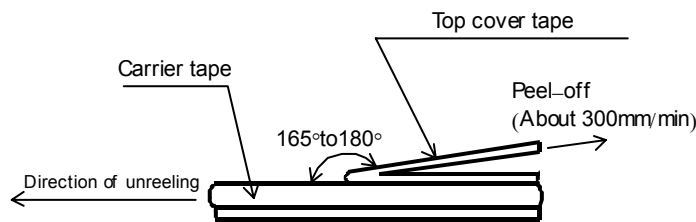

Figure-12

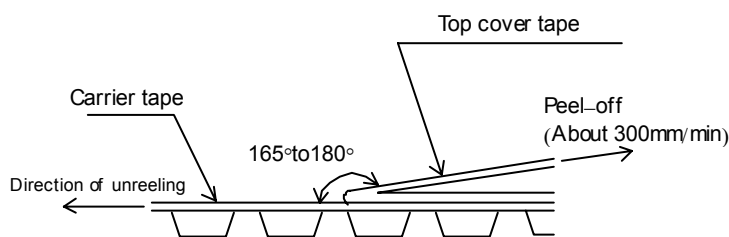

Figure-13

10.3 Reel dimension

Reel dimensions shall be in accordance with the following Figure-14 and Table-9.
Plastic reel (Based on EIAJ ET-7200B)

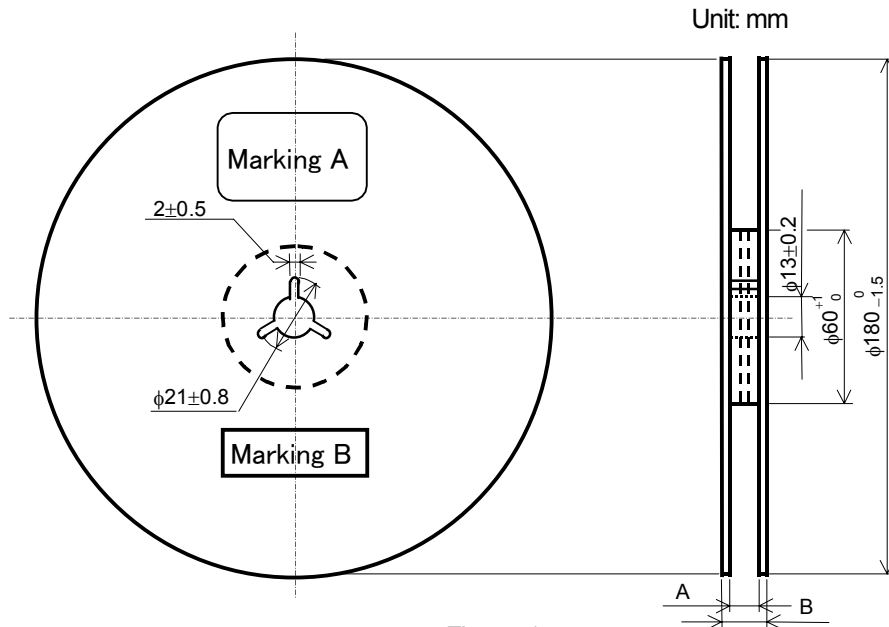

Figure-14
Table-9

Unit: mm			
Style	A	B	Note
RMC1/32, 1/20, 1/16S, 1/16, 1/10, 1/8, 1/4	9 ^{+1.0} / ₀	11.4 ± 1.0	Injection molding
		13 ± 1.0	Vacuum forming
RMC1/2, 1	13 ^{+1.0} / ₀	17 ± 1.0	Vacuum forming

Note: Marking label shall be marked on a place of Marking A or two place of marking A and B.

10.4 Leader and trailer tape.

(Example)

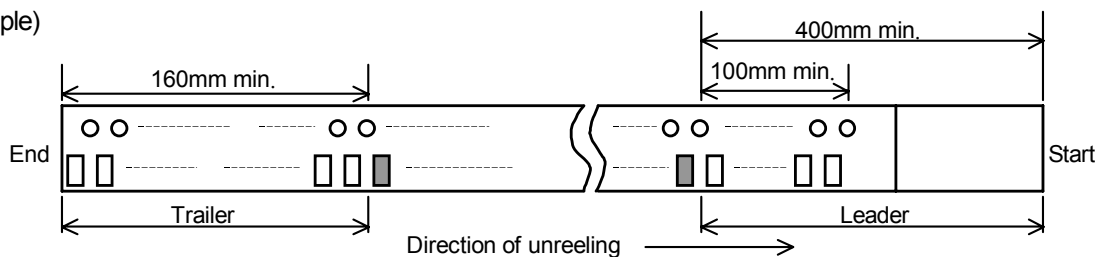

Figure-15

11. Marking on package

The label of a minimum package shall be legibly marked with follows.

11.1 Marking A

(1) Classification

(Style, Temperature coefficient of resistance, Rated resistance, Tolerance on rated resistance, Packaging form)

(2) Quantity (3) Lot number (4) Manufacturer's name or trade mark (5) Others

11.2 Marking B (KAMAYA Control label)