

**Information**

**NEC**

# **Voltage Regulator of SMD**

---

**SOT-89 (Power mini mold)**  
**MP-3Z (SC-63)**

Document No. G11872EJ3V01F00 (3rd edition)  
Date Published March 2000 N CP(K)

© NEC Corporation 2000  
Printed in Japan

[MEMO]

• **The information in this document is subject to change without notice. Before using this document, please confirm that this is the latest version.**

• No part of this document may be copied or reproduced in any form or by any means without the prior written consent of NEC Corporation. NEC Corporation assumes no responsibility for any errors which may appear in this document.

• NEC Corporation does not assume any liability for infringement of patents, copyrights or other intellectual property rights of third parties by or arising from use of a device described herein or any other liability arising from use of such device. No license, either express, implied or otherwise, is granted under any patents, copyrights or other intellectual property rights of NEC Corporation or others.

• Descriptions of circuits, software, and other related information in this document are provided for illustrative purposes in semiconductor product operation and application examples. The incorporation of these circuits, software, and information in the design of the customer's equipment shall be done under the full responsibility of the customer. NEC Corporation assumes no responsibility for any losses incurred by the customer or third parties arising from the use of these circuits, software, and information.

• While NEC Corporation has been making continuous effort to enhance the reliability of its semiconductor devices, the possibility of defects cannot be eliminated entirely. To minimize risks of damage or injury to persons or property arising from a defect in an NEC semiconductor device, customers must incorporate sufficient safety measures in its design, such as redundancy, fire-containment, and anti-failure features.

• NEC devices are classified into the following three quality grades:  
"Standard", "Special", and "Specific". The Specific quality grade applies only to devices developed based on a customer designated "quality assurance program" for a specific application. The recommended applications of a device depend on its quality grade, as indicated below. Customers must check the quality grade of each device before using it in a particular application.

Standard: Computers, office equipment, communications equipment, test and measurement equipment, audio and visual equipment, home electronic appliances, machine tools, personal electronic equipment and industrial robots

Special: Transportation equipment (automobiles, trains, ships, etc.), traffic control systems, anti-disaster systems, anti-crime systems, safety equipment and medical equipment (not specifically designed for life support)

Specific: Aircraft, aerospace equipment, submersible repeaters, nuclear reactor control systems, life support systems or medical equipment for life support, etc.

The quality grade of NEC devices is "Standard" unless otherwise specified in NEC's Data Sheets or Data Books. If customers intend to use NEC devices for applications other than those specified for Standard quality grade, they should contact an NEC sales representative in advance.

# Regional Information

Some information contained in this document may vary from country to country. Before using any NEC product in your application, please contact the NEC office in your country to obtain a list of authorized representatives and distributors. They will verify:

- Device availability
- Ordering information
- Product release schedule
- Availability of related technical literature
- Development environment specifications (for example, specifications for third-party tools and components, host computers, power plugs, AC supply voltages, and so forth)
- Network requirements

In addition, trademarks, registered trademarks, export restrictions, and other legal issues may also vary from country to country.

## **NEC Electronics Inc. (U.S.)**

Santa Clara, California  
Tel: 408-588-6000  
800-366-9782  
Fax: 408-588-6130  
800-729-9288

## **NEC Electronics (Germany) GmbH**

Duesseldorf, Germany  
Tel: 0211-65 03 02  
Fax: 0211-65 03 490

## **NEC Electronics (UK) Ltd.**

Milton Keynes, UK  
Tel: 01908-691-133  
Fax: 01908-670-290

## **NEC Electronics Italiana s.r.l.**

Milano, Italy  
Tel: 02-66 75 41  
Fax: 02-66 75 42 99

## **NEC Electronics (Germany) GmbH**

Benelux Office  
Eindhoven, The Netherlands  
Tel: 040-2445845  
Fax: 040-2444580

## **NEC Electronics (France) S.A.**

Velizy-Villacoublay, France  
Tel: 01-30-67 58 00  
Fax: 01-30-67 58 99

## **NEC Electronics (France) S.A.**

Spain Office  
Madrid, Spain  
Tel: 91-504-2787  
Fax: 91-504-2860

## **NEC Electronics (Germany) GmbH**

Scandinavia Office  
Taebby, Sweden  
Tel: 08-63 80 820  
Fax: 08-63 80 388

## **NEC Electronics Hong Kong Ltd.**

Hong Kong  
Tel: 2886-9318  
Fax: 2886-9022/9044

## **NEC Electronics Hong Kong Ltd.**

Seoul Branch  
Seoul, Korea  
Tel: 02-528-0303  
Fax: 02-528-4411

## **NEC Electronics Singapore Pte. Ltd.**

United Square, Singapore 1130  
Tel: 65-253-8311  
Fax: 65-250-3583

## **NEC Electronics Taiwan Ltd.**

Taipei, Taiwan  
Tel: 02-2719-2377  
Fax: 02-2719-5951

## **NEC do Brasil S.A.**

Electron Devices Division  
Rodovia Presidente Dutra, Km 214  
07210-902-Guarulhos-SP Brasil  
Tel: 55-11-6465-6810  
Fax: 55-11-6465-6829

J99.1

## 1. INTRODUCTION

In recent years electronic devices such as camcorders, notebook PCs, and cellular telephones, have been increasingly miniaturized. In response, the need for smaller and lighter semiconductor devices and electronic components employed for these systems to increase the mounting density on PC boards has intensified.

NEC offers SOT-89 and MP-3Z surface-mount packages for power supply ICs.

This document explains the characteristics and taping specifications of the SOT-89 and MP-3Z packages.

## 2. DIMENSIONS

Figure 1 shows the dimensions of the SOT-89 package, and Figure 2 shows the dimensions of the MP-3Z package.

Figure 1. SOT-89 Dimensions (unit: mm)

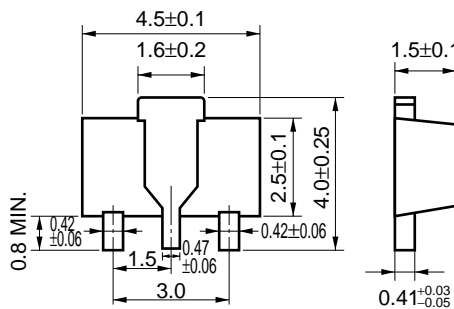
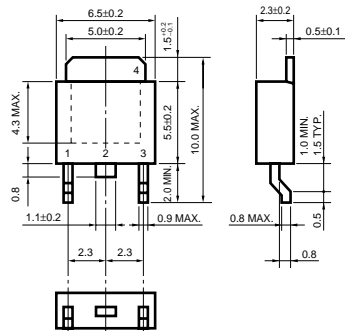

Figure 2. MP-3Z Dimensions (unit: mm)



### 3. CHARACTERISTICS

Because of the construction, the SOT-89 and MP-3Z packages change their thermal characteristics, i.e., total power dissipation, depending on the material and area of the PC board on which the packages are to be mounted.

The Data Sheet for a power IC housed in the SOT-89 package shows the total power dissipation when the package is mounted on a ceramic PC board. Figure 3 shows the total power dissipation when the package is mounted on a glass epoxy board.

Figures 4 and 5 show the typical mounting pad dimensions.

The recommended soldering conditions are described in the Data Sheet of each product. Be sure to read this description.

**Figure 3. Size of Glass Epoxy Board and Total Power Dissipation of SOT-89**

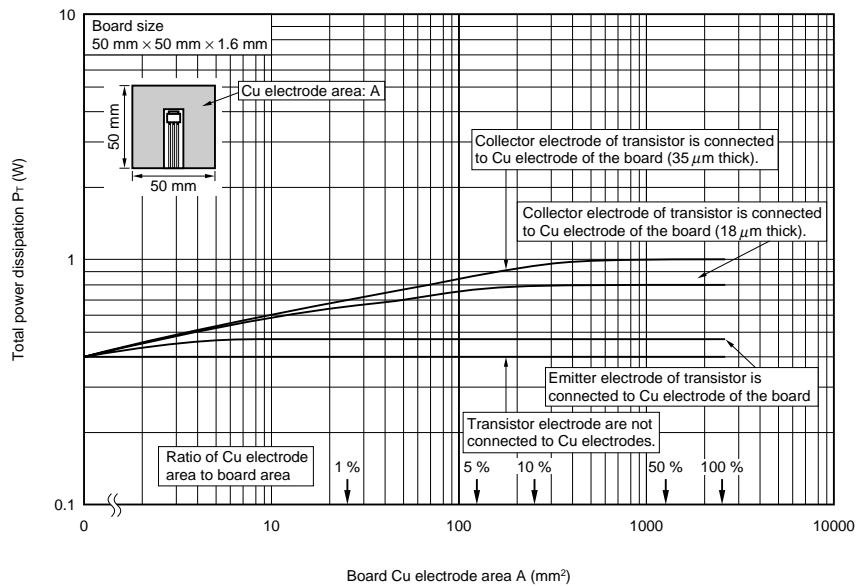
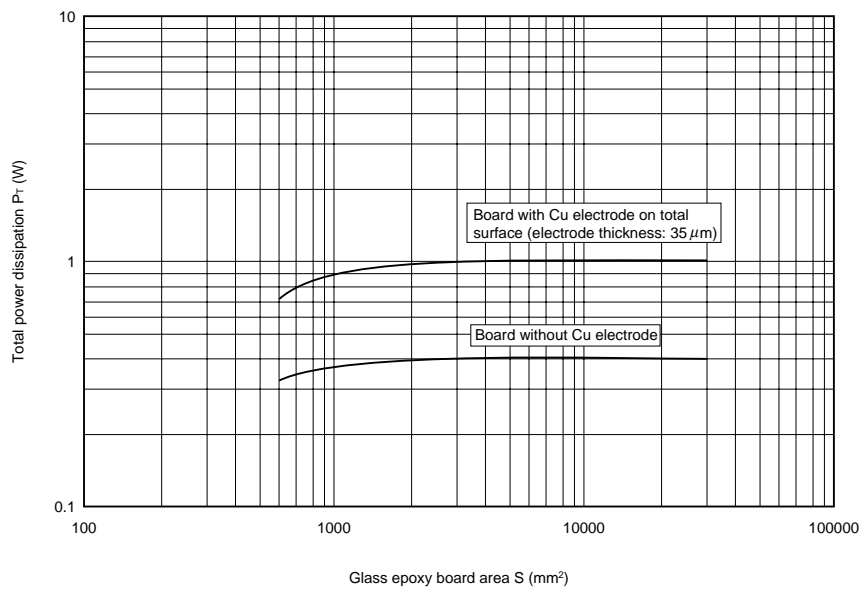

Figure 4. SOT-89 Typical Mounting Pad Dimensions (unit: mm)

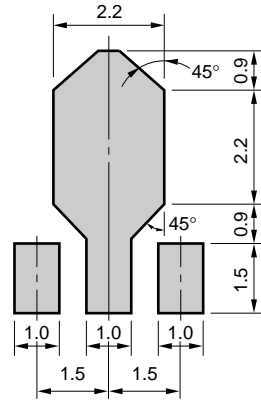
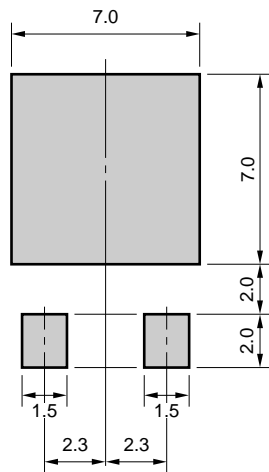

Figure 5. MP-3Z Typical Mounting Pad Dimensions (unit: mm)



#### 4. TAPING SPECIFICATIONS

The SOT-89 and MP-3Z packages can be delivered on a tape like other ICs.

Figures 6 and 7 show the tape shape and dimensions. Figures 8 and 9 show the reel shape.

**Figure 6. SOT-89 Tape Dimensions (12 mm embossed-type carrier tape)**

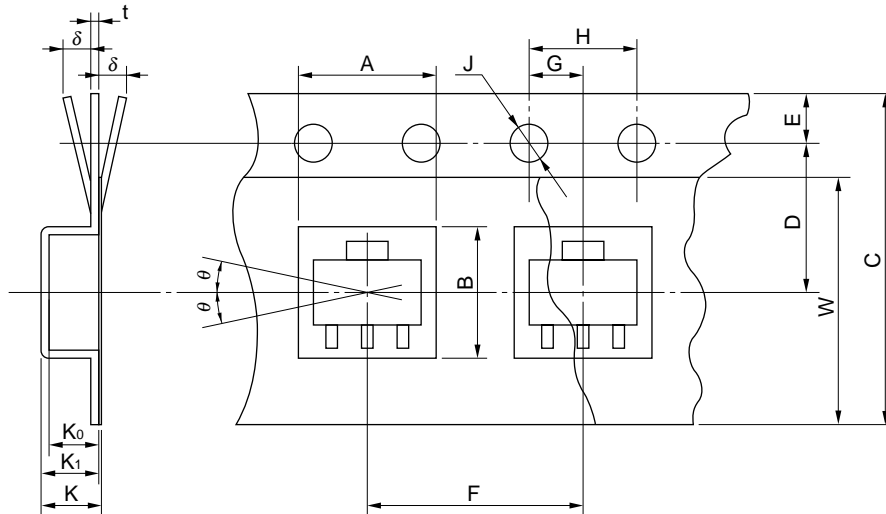

Unit: mm

| Item                                  | Symbol      | Dimensions, Angle | Remark                    |   |
|---------------------------------------|-------------|-------------------|---------------------------|---|
| Recessed hole for component insertion | Height      | A                 | $5.0^{+0.1}_{-0.1}$       | Inner side of edge on surface 0.5 mm above inner bottom |
|                                       | Width       | B                 | $4.6^{+0.1}_{-0.1}$       | Inner side of edge on surface 0.5 mm above inner bottom |
|                                       | Depth       | K <sub>0</sub>    | 1.8±0.1                   | Internal space  |
|                                       | Pitch       | F                 | 8.0±0.1                   | Total error: $^{+0.1}_{-0.3}$ MAX./10 pitch             |
| Feeding hole                          | Diameter    | J                 | $\phi 1.5^{+0.1}_{-0.05}$ |   |
|                                       | Pitch       | H                 | 4.0±0.1                   | Total error: $^{+0.1}_{-0.3}$ MAX./10 pitch             |
|                                       | Position    | E                 | 1.5±0.1                   | Distance between edge of tape and center of hole        |
| Distance between center lines         | Vertical    | G                 | 2.0±0.05                  | Center line of recessed hole and feeding hole           |
|                                       | Horizontal  | D                 | 5.65±0.05                 | Center line of recessed hole and feeding hole           |
| Cover tape                            | Width       | W                 | $9.5^{+0.3}_{-0}$         | Thickness: 0.1 MAX.                                     |
| Carrier tape                          | Width       | C                 | 12±0.2                    | Warp $\delta$ 0.3 MAX.                                  |
|                                       | Thickness   | t                 | 0.3±0.05                  |   |
|                                       | Hole depth  | K <sub>1</sub>    | 2.1±0.1                   |   |
| Device                                | Inclination | $\theta$          | 30° MAX.                  |   |
| Total thickness                       |             | K                 | 2.15±0.1                  | Total of cover tape and carrier tape                    |



Figure 7 (A). MP-3Z Tape Dimensions (16 mm embossed-type taping)

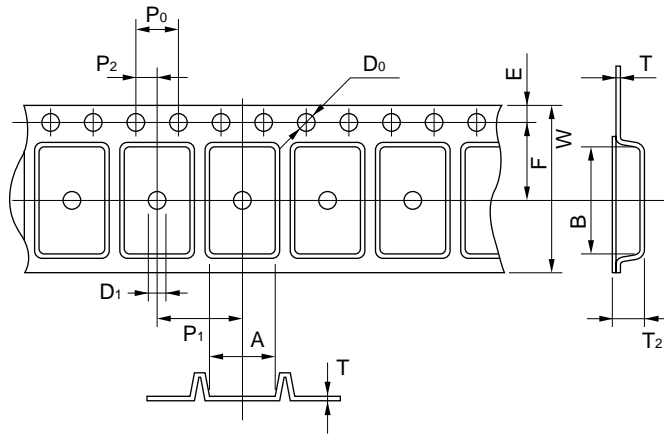

Unit: mm

| Symbol         | Standard               |
|----------------|------------------------|
| A              | 7.1 MAX.               |
| B              | 10.7 MAX.              |
| D <sub>0</sub> | $\phi 1.5^{+0.1}_{-0}$ |
| D <sub>1</sub> | $\phi 1.5$ MIN.        |
| E              | $1.75 \pm 0.1$         |
| F              | $7.5 \pm 0.1$          |
| P <sub>0</sub> | $4.0 \pm 0.1$          |
| P <sub>1</sub> | $8.0 \pm 0.1$          |
| P <sub>2</sub> | $2.0 \pm 0.1$          |
| T              | 0.2                    |
| T <sub>2</sub> | $2.7 \pm 0.1$          |
| W              | $16.0 \pm 0.3$         |

Figure 7 (B). MP-3Z Tape Dimensions (32 mm adhesive-type taping)

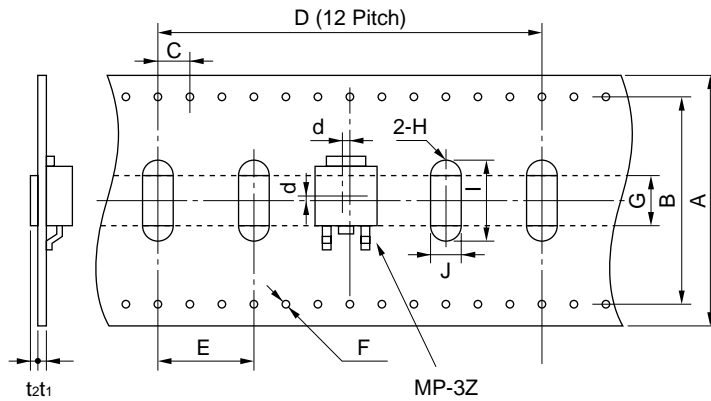

Unit: mm

| Symbol         | Standard               |
|----------------|------------------------|
| A              | $32^{+0}_{-0.4}$       |
| B              | $26 \pm 0.1$           |
| C              | $4.0 \pm 0.1$          |
| D              | $48 \pm 0.3$           |
| E              | $12 \pm 0.1$           |
| F              | $\phi 1.0^{+0.1}_{-0}$ |
| G              | $6.0 \pm 0.2$          |
| H              | R2.0                   |
| I              | 8.0                    |
| J              | 4.0                    |
| t <sub>2</sub> | 0.15                   |
| t <sub>1</sub> | 0.18                   |
| d              | $0 \pm 0.5$            |

Figure 8. SOT-89 Reel Dimensions

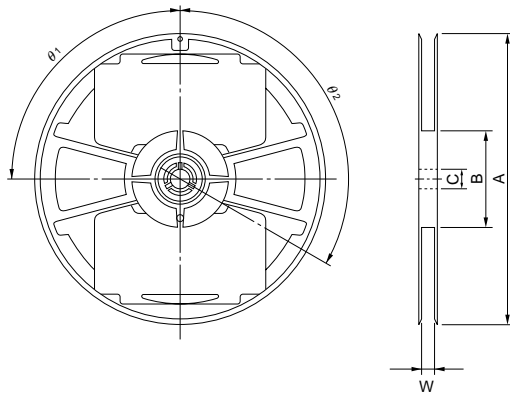

Unit: mm

| Symbol     | Dimensions, Angle |
|------------|-------------------|
| A          | $\phi 178 \pm 2$  |
| W          | $13 \pm 0.5$      |
| B          | $\phi 60 \pm 1$   |
| $\theta_1$ | $90^\circ$        |
| C          | $\phi 13 \pm 0.5$ |
| $\theta_2$ | $120^\circ$       |

Figure 9 (A). MP-3Z Reel Dimensions (embossed-type taping)

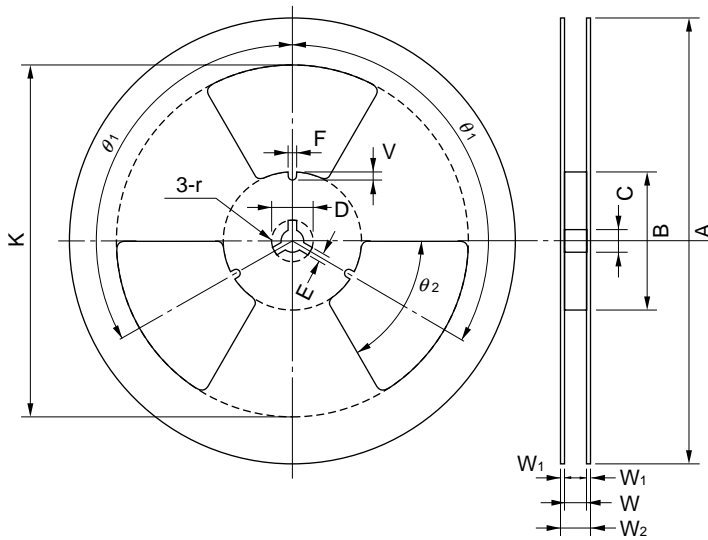

Unit: mm

| Symbol         | Standard           |
|----------------|--------------------|
| A              | 329                |
| B              | 100                |
| C              | $13 \pm 0.5$       |
| D              | $21 \pm 0.8$       |
| E              | $2.0 \pm 0.5$      |
| F              | 2                  |
| V              | 8                  |
| W              | $16.4^{+2.0}_{-0}$ |
| W <sub>1</sub> | (2.5)              |
| W <sub>2</sub> | 22.4 MAX.          |
| K              | 260                |
| r              | 1.0                |
| $\theta_1$     | 120                |
| $\theta_2$     | 60                 |

**Figure 9 (B). MP-3Z Reel Dimensions (adhesive-type taping)**

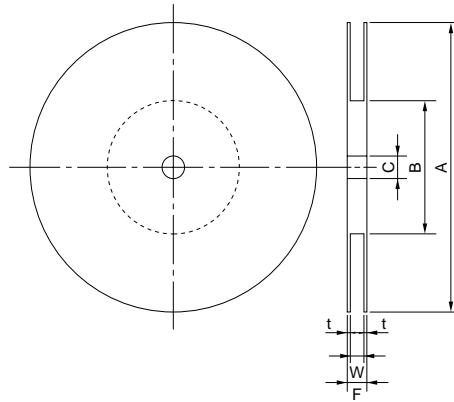

Unit: mm

| Symbol | Dimensions, Angle |
|--------|-------------------|
| A      | $\phi 300$        |
| B      | $\phi 80$         |
| C      | $\phi 15.5$       |
| W      | 34                |
| t      | 2                 |
| F      | $38 \pm 1$        |

The direction of a taped product is as shown in Figures 10 and 11. The part number of a taped product, including the symbol indicating the direction, is as follows:

**Note** The part number of the taped product of the SOT-89 package differs from those of discrete devices such as transistors and diodes.

**Figure 10. SOT-89 Taping Direction**

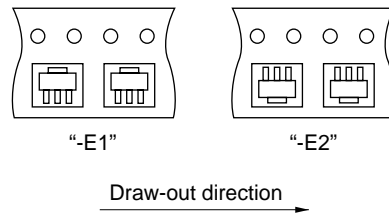

**Figure 11. MP-3Z Taping Direction**

**(A) Embossed-type taping**

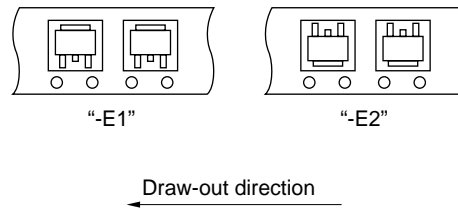

**(B) Adhesive-type taping**

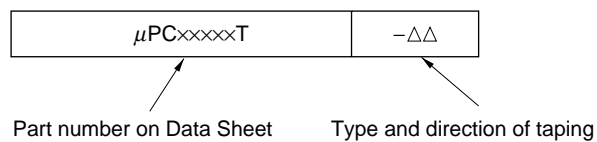
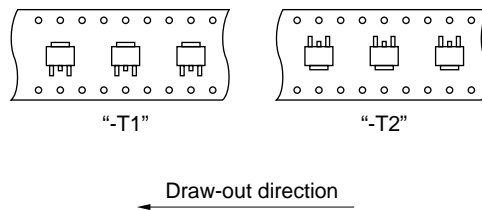

Table 1 shows the number of packages on a tape.

**Table 1. Number of Packages per Tape**

| Package                 | Quantity (units/reel) |
|-------------------------|-----------------------|
| SOT-89                  | 1000                  |
| MP-3Z (embossed taping) | 2000                  |
| MP-3Z (adhesive taping) | 1500                  |

[MEMO]

## Facsimile Message

Although NEC has taken all possible steps to ensure that the documentation supplied to our customers is complete, bug free and up-to-date, we readily accept that errors may occur. Despite all the care and precautions we've taken, you may encounter problems in the documentation. Please complete this form whenever you'd like to report errors or suggest improvements to us.

From:

Name

Company

Tel.

FAX

Address

*Thank you for your kind support.*

**North America**

NEC Electronics Inc.  
Corporate Communications Dept.  
Fax: 1-800-729-9288  
1-408-588-6130

**Hong Kong, Philippines, Oceania**

NEC Electronics Hong Kong Ltd.  
Fax: +852-2886-9022/9044

**Asian Nations except Philippines**

NEC Electronics Singapore Pte. Ltd.  
Fax: +65-250-3583

**Europe**

NEC Electronics (Europe) GmbH  
Technical Documentation Dept.  
Fax: +49-211-6503-274

**Korea**

NEC Electronics Hong Kong Ltd.  
Seoul Branch  
Fax: 02-528-4411

**Japan**

NEC Semiconductor Technical Hotline  
Fax: 044-548-7900

**South America**

NEC do Brasil S.A.  
Fax: +55-11-6465-6829

**Taiwan**

NEC Electronics Taiwan Ltd.  
Fax: 02-2719-5951

I would like to report the following error/make the following suggestion:

Document title: \_\_\_\_\_

Document number: \_\_\_\_\_ Page number: \_\_\_\_\_

\_\_\_\_\_

\_\_\_\_\_

\_\_\_\_\_

If possible, please fax the referenced page or drawing.

| Document Rating    | Excellent                | Good                     | Acceptable               | Poor                     |
|--------------------|--------------------------|--------------------------|--------------------------|--------------------------|
| Clarity            | <input type="checkbox"/> | <input type="checkbox"/> | <input type="checkbox"/> | <input type="checkbox"/> |
| Technical Accuracy | <input type="checkbox"/> | <input type="checkbox"/> | <input type="checkbox"/> | <input type="checkbox"/> |
| Organization       | <input type="checkbox"/> | <input type="checkbox"/> | <input type="checkbox"/> | <input type="checkbox"/> |

This datasheet has been download from:

[www.datasheetcatalog.com](http://www.datasheetcatalog.com)

Datasheets for electronics components.