

Technical Publication

LOR-1

HIGH SPEED MULTI-CONTACT LOCK-OUT RELAYS

FOR POWER INDUSTRY APPLICATIONS



**ELECTROSWITCH
SWITCHES & RELAYS**

UNIT OF ELECTRO SWITCH CORP.

180 King Avenue, Weymouth, Massachusetts 02188

Phone: 781-335-5200 Fax: 781-335-4253

www.electroswitch.com

HIGH SPEED MULTI-CONTACT LOCK-OUT RELAYS FOR POWER INDUSTRY APPLICATIONS

ELECTROSWITCH
Weymouth, Massachusetts

ABSTRACT

The Series 24 Lock-out Relays are high-speed (as low as eight milliseconds) control relays used primarily as auxiliary relays in applications requiring many contacts (up to 48). The LOR is an electric-trip and manual-reset device. The LOR/ER is an electric-trip and either manual or electric-reset. The LOR/SR is an electric-trip and self-reset device. All units have mechanical position indicator targets. They are qualified to ESC-STD-1000, which includes aging and seismic vibration requirements to ANSI/IEEE 323-1984 and ANSI/IEEE-344-1987 for class IE uses in nuclear power generating stations. The testing also satisfies ANSI/IEEE C17.90-1989 and ANSI/IEEE C37.98-1987.

INTRODUCTION

Lock-out Relays of various types are often used in the electrical power industry. These auxiliary relays are electric-trip, manual or electric-reset control relays for the purpose of tripping and locking out circuit breakers or other devices automatically when a fault or other pre-determined condition exists. Lock-out-relays are generally used in conjunction with protective relays to protect transformers, buses, and rotating machinery in various electrical systems.



Fig. 1. Series 24 LOR Manual-reset Lock-out Relay

Initial Release – September 15, 1977
Revised – January 3, 1980
Added LOR/SR – February 1, 1983
Revised – March 15, 1985
Revised – April 15, 1987
Revised – June 1, 1991
Revised – February 15, 1993
Revised – February 10, 1994
Revised – September 1, 2012

Lock-out Relay applications often require ten or more N.O. and N.C. contacts. The relays can be used to change sequences such as shutting down a faulty pump and then initiating the action to start-up a standby pump or bypassing a faulty circuit by opening and closing breakers.

Lock-out-relays are normally latched in the RESET position and trip-out to a TRIP position when commanded. There are then manual-reset, electric-reset, and self- reset versions to get back to the RESET position.

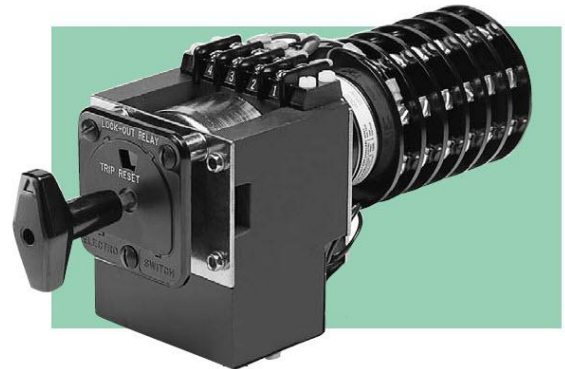

Fig. 2. Series 24 LOR/ER Electric-reset Lock-out Relay and LOR/SR Self-reset Lock-out Relay

High-speed, rugged, multi-contact units are needed. This paper describes a family of Lock-out relays with up to 48 contacts that operate as quickly as eight milli-seconds and are seismic shockproof.

BASIC CIRCUIT OPERATION

The control of the Lock-out Relays for operation as a relay requires no special wiring. They only require a N.O. contact (S1) to command the LOR to TRIP and the Electric-reset LOR/ER needs an additional N.O. contact (S2) to initiate the command for RESET. The choice of S1 should take in consideration the burden data of trip coil, LOR/T, since S1 will "make" this current. This circuit is self-interrupting with the LOR contacts so S1 need not be concerned with the "break" of the TRIP circuit. On the electric-reset LOR, S2 needs to make only the K1 relay circuit so the burden of the LOR/R does not affect S2. Any pilot duty device is acceptable for both S1 and S2.

Manual-reset LOR Circuit

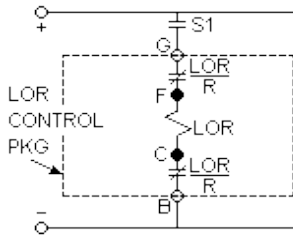

Fig. 3. Manual-reset LOR Control Circuit Schematic (shown in RESET position)

The standard station control bus voltage is used. The LOR, as shown, is in the RESET position. The LOR/T coil form represents the linear solenoid that releases the latch that locks the LOR in the RESET. The mechanical design is described later under THE ELECTRO-MECHANICAL DRIVE.

The LOR contacts shown are normally closed in the reset position. They are within the LOR control package. G and B are tie points to connect the LOR to the control circuit. C and F are internal connection points shown for information.

To command the Lock-out Relay to TRIP, S1 is closed. This completes a circuit across the LOR trigger solenoid, which operates, causing the device to snap to the TRIP position. It locks into this position and remains there indefinitely. When this happens, the LOR contacts open, thereby removing the control circuit from the bus.

The unit will stay locked-out in the TRIP position until manually reset. S1 may be an auxiliary contact – from a breaker, a protective relay, or from another auxiliary device like a relay. The condition of the Lock-out Relay is visible by the handle location and a mechanical target within the nameplate (Black for RESET, Orange for TRIP)

Electric-reset LOR/ER Circuit

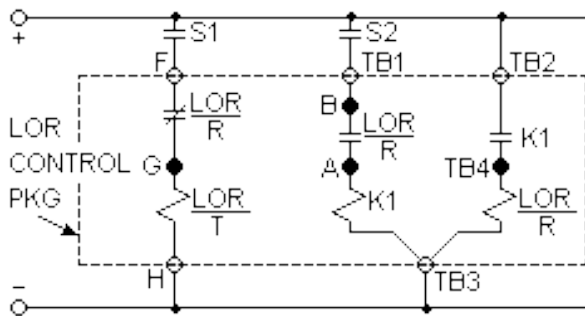

Fig. 4. Electric-reset LOR/ER Control Circuit Schematic (shown in the RESET position)

The Electric-reset Lock-out Relay operates from the control bus voltage like the manual-reset version. The LOR/ER, as shown, is in the RESET POSITION. The LOR/T coil form is the same linear solenoid that is used in the manual-reset LOR, and controls the latch that locks the LOR/ER in the RESET position. The LOR/R coil form represents the rotary solenoid that is used to reset the LOR/ER electrically. K1 is a relay used to control the rotary solenoid. This enables S2 to be a low level contact. It controls only the K1 relay coil. The K1 contact operates the high current rotary solenoid. TB1, TB2, and TB3 are terminal block connections, and F and H are LOR tie points – all are for connection to the control bus. G, B, and TB4 are internal tie points shown for information only.

The command of the LOR/ER to the TRIP position is the same as with the manual-reset LOR which was previously described. When tripped, the NC LOR contact in the LOR/T circuit opens removing LOR/T solenoid from the circuit. When this happens, the LOR NO contact in the K1 relay circuit closes enabling this circuit to be used.

To command the LOR/ER to reset, S2 is closed. This completes the circuit to the K1 relay and it operates closing contact K1. This completes the circuit to the LOR/R rotary solenoid and it indexes to the RESET position. When this happens, the N.O. LOR contact opens. This opens the circuit on the K1 relay coil. The K1 relay drops out, opening contact K1 that opens the rotary solenoid LOR/R circuit. At the same time, the N.C. LOR contact, in the linear solenoid LOR/T circuit, closes, setting up the LOR/ER for the next TRIP command.

S1 and S2 should be momentary contacts and should not stay closed. If both contacts are closed at the same time, a "pumping" action will result with the LOR/ER indexing back and forth between the RESET and TRIP positions.

The handle and target indicators are the same on the standard electric-reset LOR/ER as the manual reset LOR. The handle on the high-speed LOR/ER is not an indicator and remains in the vertical position and the target must be manually reset (see page 9).

Self-reset LOR/SR Circuits

The self-reset Lock-out Relay operates from the control bus voltage like the LOR and LOR/ER. The LOR/SR, as shown in Fig. 5 and 6, is in the RESET position. The LOR/T coil is the same linear solenoid that is used in all LOR's, and controls the trigger that locks the LOR/SR in the RESET position. The LOR/R is the same rotary solenoid used in the LOR/ER and is used to electrically reset the LOR/SR. K1 and K2 are two relays with N.O. contacts used in the control circuit. B-A is a N.O. contact and E-F-G is a form "C" contact -- both in the control circuit. F-G is N.C. in the reset position while F-E is N.O. TB1, TB2, TB3, and TB4 are terminal block connection points for the user. R1 and R2 make up a bridge circuit on

both the INSTANTANEOUS RESET and the TIME DELAY RESET units. In addition, the TIME DELAY RESET version has an additional IE-IF normally open (NO) contact to isolate the K2 coil plus the time delay circuit, consisting of R1 and C1-C2-C3-C4, which are wired in parallel. D1 protects the capacitors from a possible incorrect polarity hookup.

The INSTANTANEOUS RESET version of the LOR/SR will reset itself within 80 milliseconds after the fault has cleared itself (S1 opens). This circuit is illustrated in Fig. 5.

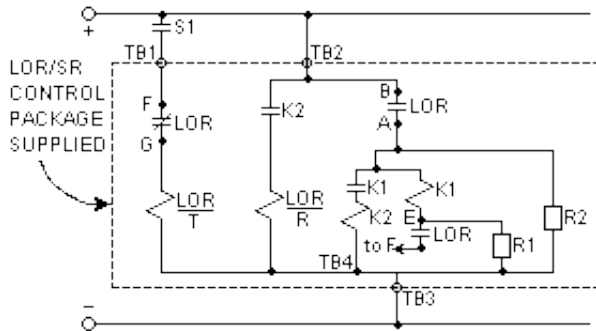

Fig. 5. Instantaneous-reset circuit for the Self-reset (shown in RESET position) Lock-out relay

The LOR/SR trips in the same manner as the manual-reset LOR. With S1 closed (simulating the commanded or fault condition) B-A contact closes and E-F contact closes. In this manner E-F and A-B are both connected to the (+) bus so the K1 coil sees no voltage difference and cannot operate. Therefore, the LOR/SR will not reset and may remain in the TRIP position indefinitely while the RIR2 bridge draws only enough milliamps to maintain the voltage balance of the bridge and well below the dropout current of any 0.2 amp. target relays that may be part of the circuit.

When S1 opens (indicating the fault or pre-determined condition has cleared), the RIR2 bridge becomes unbalanced since the E-F contact, although closed, is in the S1 contact circuit. K1 operates, closing contact K1 and K2 operates, closing contact K2 and the rotary solenoid LOR/R operates and indexes to the RESET position completing the cycle.

Contacts E-F and A-B then open, dropping out relays K1 and K2 (and their contacts). Contact F-G closes, setting up the LOR/SR for the next command.

The TIME DELAY SELF-RESET (shown in RESET position) version of the LOR/SR, illustrated in Fig. 6, operates in the same manner as the instantaneous reset version except the R3-C1-C2-C3-C4 circuit causes a time delay of from 300 to 600 milliseconds from the time S1 opens until the LOR/SR contacts reclose.

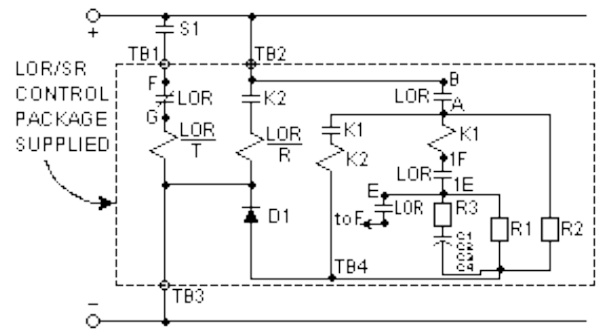

Fig.6. Time-delay Self-reset circuit for the LOR/SR

Operating Voltage

The LOR, LOR/ER, and LOR/SR Lock-out Relays are direct current actuated auxiliary relays. Because they are only actuated for short periods of time and are self-interrupting, they may be subjected to maximum design voltage indefinitely without exceeding the 50°C temperature rise in ambient conditions as high as 55°C. This is using class 105 insulation and the applied thermo-couple method of temperature determination.

The Lock-out Relays operate reliably over the full voltage ranges described in ANSI/IEEE C37.90-1989, the "Standard for Relays and Relay Systems Associated with Electric Power Apparatus." These ratings are shown below:

TABLE I
Coil Operating Range*

COIL	NOMINAL VOLTAGE	NORMAL VOLTAGE OPERATING RANGE
A, B	24 VDC	19.2 to 28 VDC
C	48 VDC	38.4 to 56 VDC
D, E, G, K	125 VDC	100 to 140 VDC
F, H	250 VDC	200 to 280 VDC

*From ANSI/IEEE C 37.90- 1989

The trip and reset solenoid coils provide reliable operation over a wide RANGE of operating conditions. Trip coils A, B, C, D, E, and F have substantial overlapping voltage ranges enabling some "custom-fitting" depending on the desired speed versus current burden. Trip coils G and H have controlled threshold voltage levels to insure that the unit will not trip at half-voltage. G and H coils are useful where cumulative stray voltages due to capacitive and other effects might be impressed on the LOR coil causing occasional nuisance trips. The full voltage ranges are shown on Tables II and III.

The Threshold Voltage shown is the minimum level that can produce a TRIP operation. This is not a reliable operation and this voltage level should not be normally used. The normal operation should be within the limits of the Operating Range.

The Operating Range represents the design limits for reliable operation. Safety factors are included so operation can

occur above and below the indicated range as previously explained.

TABLE II
Trip Coil Voltage Data

COIL	NOMINAL VOLTAGE	THRESHOLD VOLTAGE	OPERATING RANGE
A	24 VDC	6 VDC	10 - 40 VDC
B	24 VDC	9 VDC	18 - 50 VDC
C	48 VDC	12 VDC	24 - 70 VDC
D	125VDC 120 VAC	16 VDC 20 VAC	30 - 140 VDC 30 - 140 VAC
E	125 VDC	23 VDC	45 - 140 VDC
F	250 VDC 240 VAC	33 VDC 40 VAC	70 - 280 VDC 60 - 280 VAC
G	125 VDC	70 VDC	90 - 140 VDC
H	250 VDC	140 VDC	180 - 280 VDC
K	125 VDC	16 VDC	100 - 150 VDC

Note: D coil has been tested and approved for use @ 120VAC

TABLE III
Reset Coil Voltage Data

COIL	NOMINAL VOLTAGE	OPERATING RANGE
A	24 VDC	19.2 to 28 VDC
C	48 VDC	38.4 to 57.6 VDC
D	125 VDC	100 to 140 VDC
F	250 VDC	200 to 275 VDC

Coil Burden Data

The LOR, LOR/ER, and LOR/SR solenoid coil burden data is outlined in Table IV.

As previously explained, the control bus needs to be able to supply the burden detailed in Table IV but does not need to interrupt it – the units are self-interrupting. The reset coil is hard-wired to the control bus so the actuating means (S2 in Fig. 4) is not subjected to the burden (only the K1 coil burden at less than 1 ampere) S1 controlling the trip coil does “make” and carry the trip coil current.

TABLE IV
Coil Burden Data

COIL	COIL CIRCUIT VOLTS	TRIP COIL		RESET COIL	
		COIL CIRCUIT DC OHMS @ 25°C	BURDEN (amps) @ RATED VOLTAGE	COIL CIRCUIT DC OHMS @ 25°C	BURDEN (amps) @ RATED VOLTAGE
A	24 VDC	3.3	7.3	0.7	33.8
B	24 VDC	7.7	3.1	--	--
C	48 VDC	13.0	3.7	3.0	15.9
D	125 VDC	27.0	4.6	12.4	10.1
E	125 VDC	50.0	2.5	--	--
F	250 VDC	104.0	2.4	80.6	3.1
G	125 VDC	27.0	4.6	--	--
H	250 VDC	104.0	2.4	--	--
K	125 VDC	27.0	4.6	--	--

Trip Coil Current - Voltage Characteristics

The trip coils may be used over a wide range of voltage levels as previously described. To aid in this selection Fig. 7 graphs the voltage/current characteristics of the trip coils. These values are the same for the manual-reset LOR, the electric-reset LOR/ER, and the self-reset LOR/SR Lock-out Relays. Fig. 7 is used with the Response Time graph of Fig. 8. Target selection data is detailed on Table V and VI and Fig. 9 to 12.

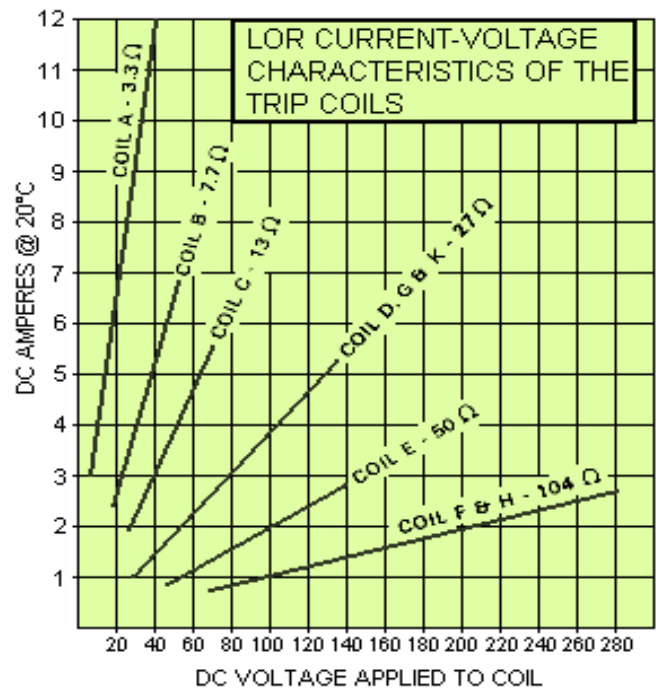

Fig. 7. Trip Solenoid Coil Burden Data

TABLE V
LOR Trip Coil Selection for Positive Target Operation

OPERATING DC VOLTS	LOR TRIP COIL TO USE	
	0.2A TARGET	2A TARGET
24	A, B, C	
48	B, C, D, E	
100	D, E, F	
125	D, E, F, G	D
140	D, E, F	D
190	F	D
250	F, H	D

TABLE VI
Suggested minimum DC Voltage required for Positive Target Operation with Manual Reset LOR. (Actual values may vary).

LOR TRIP COIL	NO ADDITIONAL CIRCUITRY (target)			2A TARGET RESISTOR (Rp) IN PARALLEL		2A TARGET R-C CIRCUIT		2A TARGET SERIES RESISTOR (Rs)		
	0.2A	0.6A	2A	25 ohm	50 ohm	40 MFD	20 MFD	7 ohm	12.3 ohm	16.7 ohm
A										90
B	12	12	42						90	
C								95		
D	24	40	118		80	95	105			
E				75	105					
F	40	150		70	125					
G	90									
H	180									

Response Time - Trip Solenoid

Fig. 8 shows the high-speed response of the Lock-out Relays. The values given are total response to close N.O. contacts. The values are for ten deck LOR's and eight deck LOR/ER's and LOR/SR's. There is very little difference in smaller units. The response time of the trip coil of the high-speed electric-reset Lockout-relays is the same as the manual-reset LOR's.

Response Time - Reset Solenoid

The reset time of the electric-reset (LOR/ER) Lock-out Relays is generally not an important applications consideration so a graph has not been prepared. The response is approximately fifty milliseconds at rated voltage for all coils. The reset times of the self-reset LOR /SR is described on page 3.

Targets used with Lock-out Relays

All the Lock-out Relays have a mechanical target as part of the nameplate - Black for RESET and Orange for TRIP. This indicates the condition of the LOR. The target resets when the LOR resets (with the exception of the high-speed trip electric- reset LOR/ER and self-reset LOR/SR where the memory target is manually reset).

The addition of the optional LIGHTED NAMEPLATE to the LOR provides local and SCADA verification of trip coil integrity. It also provides local LED indication of the presence of a continuing trip signal to the LOR, which alerts the operator not to reset a manual LOR into a fault.

The lighted nameplate has two LEDs. The right LED is controlled by the circuit that detects an incoming trip signal to the LOR. If such a signal is present, then the right LED is lit. This is important since it warns the operator not to attempt to reset the LOR with a trip signal present, which can damage the LOR trip coil.

The left LED is controlled by the circuit that monitors the LOR trip coil. When the trip coil is intact and the LOR is in the normal RESET position, this LED is lit. The same trip coil monitor circuit controls the SCADA output of the lighted nameplate. If the trip coil should open for any reason, then the SCADA output closes. The SCADA output also closes if power to the LOR is lost and when the LOR is in the TRIP position.

External targets may also be used in conjunction with the LOR's to show the condition of the devices that are being controlled. The most common 0.2A targets operate satisfactorily with an LOR. The 0.6A targets are also generally satisfactory. 2A targets need special attention. Selection of LOR trip coils are shown in Table V with minimum required DC voltages for position target operation shown on Table VI.

2A targets are generally slow acting. The response time of the LOR's is generally too fast for them to respond. From Tables V and VI, it is seen that only trip coil D will respond and only at 118VDC or more. In order to use 2A targets at lower voltages, suggested circuits have been developed. The standard circuit with no additional circuitry is shown on Fig. 9 for comparison. Figs. 10 to 12 are shown as suggested solutions. Table VI shows the minimum voltages to apply with these circuits to get position 2A target operation. These circuits were developed using target relays with coil characteristics shown on Table VII.

TABLE VII
Target Relay Coil Characteristics

TESTS BASED ON FOLLOWING TARGET COIL CHARACTERISTICS	TARGET		
	.2A	.6A	2A
Coil Resistance (ohms)	8.15	0.71	0.195
Pull-In Current (amps)	0.15	0.45	1.75

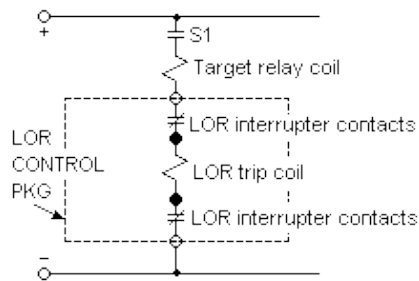

Fig. 9 typical LOR trip circuit with target relay coil in series with LOR coil

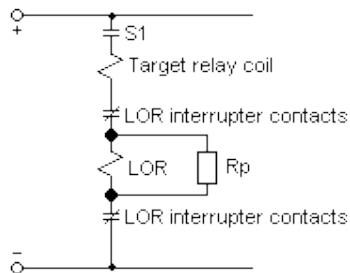

Fig. 10 LOR trip circuit with resistor (R_p) in Parallel with LOR trip coil (not supplied with LOR – see Table VI for recommended Values)

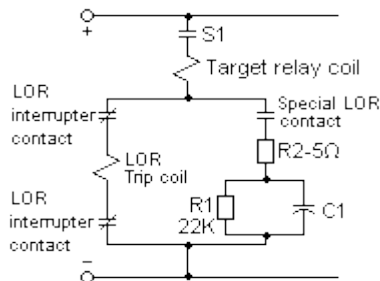

Fig. 11. LOR trip circuit with RC network -- is momentarily connected with LOR coil increasing current in 2A target. C1 discharges through R1 when LOR is reset. See Table VI for recommended values of C1. Requires special LOR. Contact Factory .

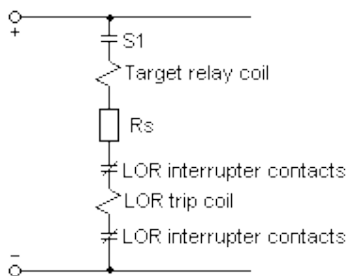

Fig. 12. LOR trip circuit with series resistor (R_s) chosen to reduce trip coil wattage. Value-chosen to obtain 5 amperes for 5 milliseconds or longer through target relay coil. See Table VI for recommended values.

Transient Protection

The LOR, LOR/ER, and LOR/SR Lock-out Relays are designed and tested to operate reliably in a normal power industry environment. This includes being subjected to transients on the control bus up to 5kV. Since the LOR is normally isolated from the Bus, it will experience transients only if they occur in the operating mode. This precludes the possibility of a detrimental, accumulating effect over the life of the unit. As such, no transient protection is needed.

Because of the nature of the operation of the solenoid coils, the LOR does generate transients that may be of interest to the user. These transients are less than 2kV and generally in the 1.5kV to 1.8kV range. In systems consisting of components that meet IEEE Std. C37.90.1 these transients will not cause any issues.

BASIC RELAY CONTACTS

The LOR, LOR/ER, and LOR/SR Lock-out Relay contacts operate on the original, reliable principle of knife switches -- double sided, double-wiping, spring wiper blades closing on both sides of a terminal. To provide a closed contact, two terminals are bridged or shunted. Fig. 13 shows this contacting arrangement.

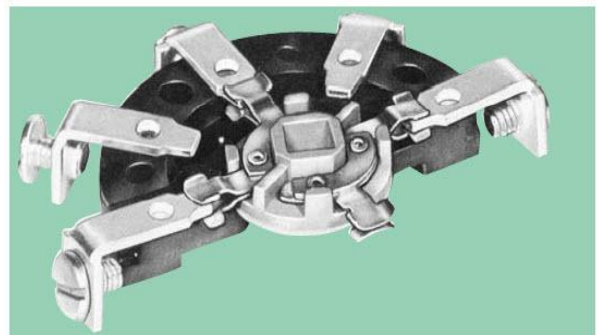

Fig. 13. Double-sided, double-wiping knife-type Contact configuration.

Contact Materials

The wiper blades are made from a phosphor-bronze alloy that combines superior spring qualities with good electrical conductivity. This material and blade design has been proven by extensive laboratory testing as well as more than thirty years of field use and experience. Initially used in rugged naval ship applications, it is also used in industrial applications such as railroad locomotives and earth moving equipment. It has been used for more than forty years in power industry applications, as well.

The blade assembly is shockproof and virtually bounce-proof. This makes it ideal for high-speed, quick-make, quick-break devices like the LOR, LOR/ER, and LOR/SR.

The blades are formed, assembled, and riveted nearly closed. The gap is machine adjusted to provide a uniform high pressure. The gap does not change with time and use. Normal use tends to improve the contact surfaces due to the rubbing action. This provides a burnishing as well as cleaning action.

The contact surface conductivity is enhanced by a silver overlay stripe that lasts the life of the unit. This ensures a good contact, even in those cases where the LOR, LOR/ER, and LOR/SR are not operated for long periods of time.

The terminals are made of electrically and environmentally compatible copper material with a silver overlay stripe at the contact area plus an overall silver plate to ensure a good, durable contact surface for customer wiring purposes. Similarly, the terminal screws are made from silver-plated brass.

Number of Decks Available

Table VIII shows the maximum number of decks and contacts available for reliable operation:

TABLE VIII
MAXIMUM DECKS AVAILABLE

LOR TYPE	MAXIMUM DECKS	MAXIMUM CONTACTS
LOR	12	48
LOR/ER HI SPEED TRIP	10	40
LOR/ER STD SPEED TRIP	8	32
LOR/SR INSTANT RESET	8	32
LOR/SR TIME DELAY RESET	7	28

Contact Deck Arrangement

The blade and terminal configuration enables the use of multi-contacts in the same deck, and simple stacking procedures enable the fabrication of many independent contacts in one relay. Specifically, two NO contacts and two NC contacts are provided in each deck, and up to twelve decks can be stacked, resulting in a relay with up to 48 contacts (24 N.O. and 24 N.C.). The deck arrangement is illustrated in Fig. 14.

The contacts operate reliably, using every contact and terminal illustrated. For good practice, however, it is suggested that polarized voltages having opposite polarity should not be used on adjacent contacts. This is because of the remote possibility of flashover during transition between adjacent contacts -- especially at the higher DC ratings, or in highly inductive circuits.

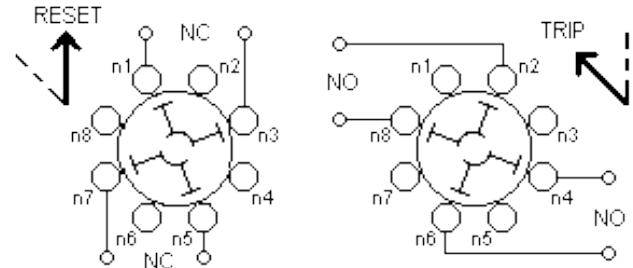

Fig. 14. Basic LOR Deck Layout

The illustration of Fig. 14 is for the first deck. For multi-deck units the second digit of the terminal number is the same as shown but the first digit changes to denote the deck number. As an example, terminal 82 is in the eighth deck, directly under terminal 12 and used together with terminal 88.

Contact Charts

The previous illustration shows how the LOR's are constructed and is shown as information for the user. Traditional contact charts are normally used, as shown on Fig. 15.

DECK	CONTACTS	POS.	
		TRIP	RESET
1	11-O-H-H-O-13		X
	12-O-H-H-O-18	X	
	15-O-H-H-O-17		X
	16-O-H-H-O-14	X	
2	21-O-H-H-O-23		X
	22-O-H-H-O-28	X	
	25-O-H-H-O-27		X
	26-O-H-H-O-24	X	
	...		X
	...	X	

Fig. 15. LOR, LOR/ER, and LOR/SR Lock-out relay Chart

Contact Ratings

The LOR, LOR/ER, and LOR/SR Lock-out relays have been tested to many different circuit conditions. The interrupting ratings are based on 10,000 operations of life, using suddenly applied and removed rated voltage, with no extensive burning of contacts. Inductive ratings are based on tests and using standard inductance L/R=0.04 for DC and cosθ=0.4 for AC. Short-time and continuous ratings are based on temperature rise in contact members and supporting parts not exceeding 50°C above ambient.

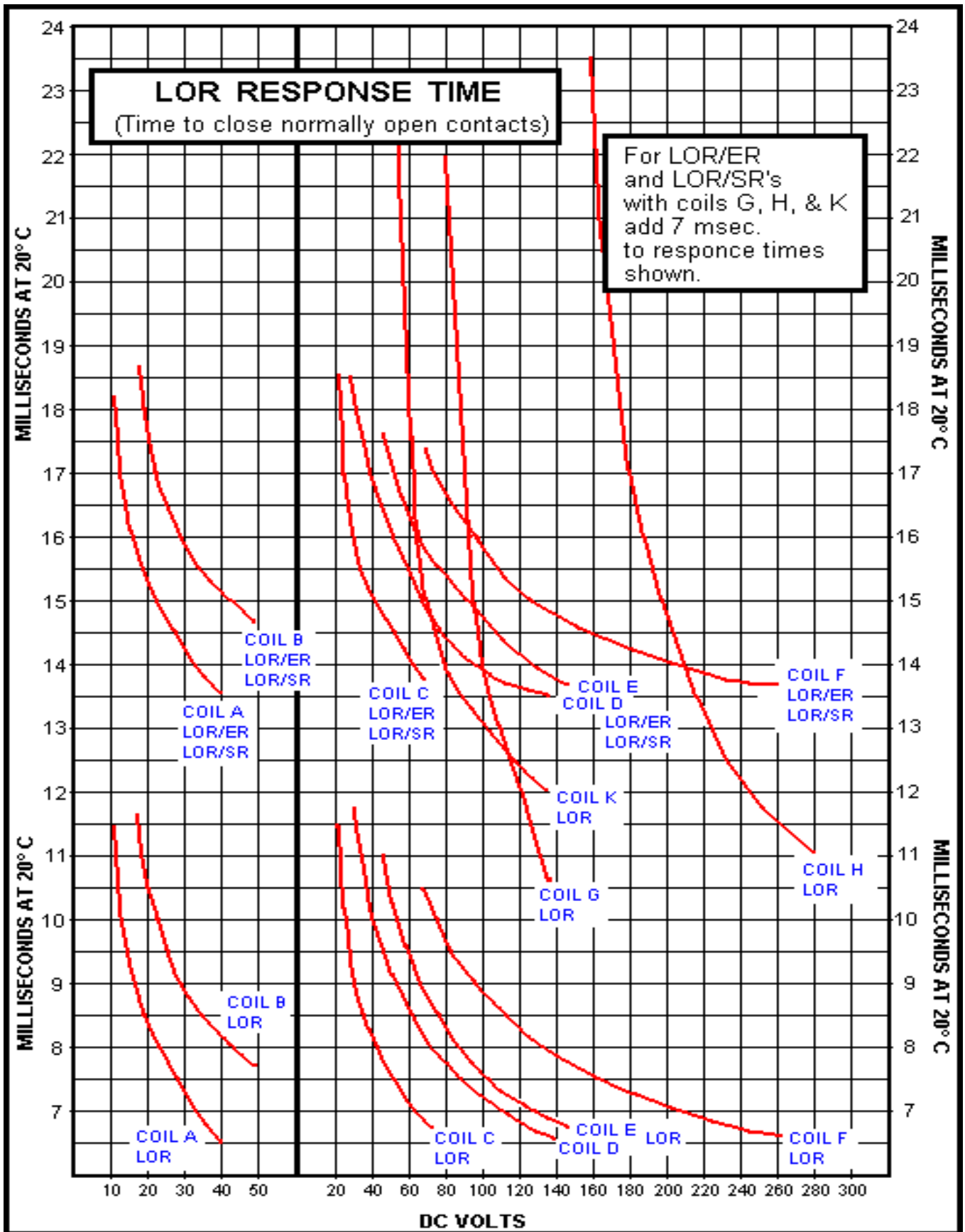

Fig. 8. LOR/ER and LOR/SR Lock-out Relay response times (10 deck LOR, 8 deck LOR/ER or LOR/SR. For high-speed LOR/ER or LOR/SR's, use LOR response times.

Allowable Variation From Rated Voltage

The relay contacts are not sensitive to normal variations in voltage. The interrupting capacity is important as indicated in Table IX. Variations of plus and minus twenty percent in rated voltage need not be considered as long as the interrupting current is not exceeded.

TABLE IX
Contact Ratings for Series 24 LOR, LOR/ER,
and LOR/SR Lock-out Relays

CONTACT CIRCUIT VOLTS	INTERRUPTING RATING (amps)		SHORT TIME RATING* (amps)	CONTINUOUS RATING (amps)
	RESISTIVE	INDUCTIVE		
	SINGLE CONTACT	SINGLE CONTACT		
125 VDC	3	1	60	30
250 VDC	2	1/2	60	30
120 VAC	20	15	60	30
240 VAC	15	5	60	30
480 VAC	10	5	60	30
600 VAC	6	5	60	30

*The making ability for 125VDC circuit breaker coils is 95A-125VDC. Short-time is for 1 minute.

THE ELECTROMECHANICAL DRIVE

The switch portion of the Lock-out Relay is the field proven Series 24 Instrument and Control Switch. In this application, it is a two-position device – TRIP and RESET. There is a powerful coil spring mechanism to drive it from the RESET position to the TRIP position. The device is held in the RESET position by a latch and locking mechanism. This is released by a small linear solenoid for electric tripping. The LOR is manually reset by rotating the handle against the coil springs. The LOR/ER is either manually reset or electrically reset utilizing a separate rotary solenoid mechanism. The LOR/SR is self-resetting when the tripping condition has been removed. These mechanisms are described below.

The TRIP Mechanism (Patent #3649793)

Industry requirements for Lock-out Relays include:

- *high-speed
- *seismic shock-proof
- *multiple contacts

To get the multi-contact feature and maintain positive and rugged action, heavy spring action is required. This requires a locking mechanism to hold back a spring wind-up of forty-inch pounds of torque. To get high-speed release, a solenoid is needed. Ordinarily, a large solenoid is required to do this. Large solenoids are inherently slow so a small linear solenoid is used to release the latch. By nature, small linear solenoids do not develop much force, so a mechanical advantage is needed.

The trigger mechanism was invented to provide the mechanical advantage. One pound of force from the linear solenoid releases the latch that locks the device against forty inch pounds of torque. The trigger uses the principle of coincident radii of two rollers – one cannot roll without the other. The two rollers are shown in Fig. 16.

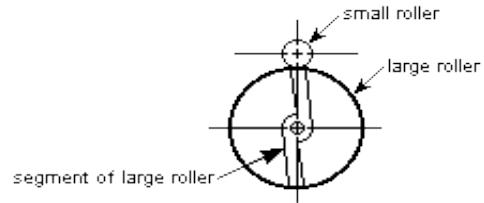

Fig. 16. Relationship of two rollers with coincident radii

The relationship of roller sizes is to get the mechanical advantage needed. Since only a small part of the larger roller is needed, a segment was cut out to reduce size and inertia.

Fig. 17 shows the small roller, large roller segment, and their relationships with the linear solenoid and the relay operating shaft.

As shown, the trip mechanism is in the RESET position. This was done by rotating the handle and relay shaft (1) clockwise against the relay shaft stop pin (2). When the roller arm (3) and the small roller (4) clear the large roller segment (5), the retaining spring (6) positions the large segment (5) against the stop pin (7).

The handle and shaft (1) is now released, allowing the roller arm (3) to spring return counterclockwise until the small roller (4) comes to rest on the large roller segment (5). When the two rollers contact, the mechanical force generated acts along coincident radii (common centerline). Neither roller can rotate; the LOR is locked and reset.

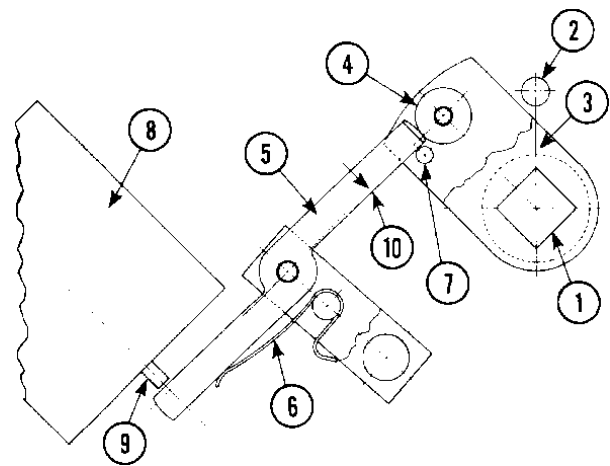

Fig. 17. LOR TRIP Mechanism

To initiate a TRIP action the linear solenoid (8) is actuated. The solenoid push rod (9) provides a one pound release force to the large roller segment (5) moving it by the release distance (10). When this happens, the roller arm (3) is free to rotate counterclockwise to the TRIP position where an internal stop mechanism stops the rotation.

The RESET Mechanism

The manual reset LOR is reset by manually turning the relay handle clockwise to the RESET position where it locks in. The electric-reset LOR/ER is either manually reset the same way or electrically reset using the solenoid circuit previously described. The LOR/SR self-resets with a solenoid circuit similar to the LOR/ER.

The HIGH-SPEED-TRIP Electric-reset Mechanism

The high-speed TRIP electric-reset or self-reset Lock-out Relay has two features used to accomplish a reliable tripping action in less than eight milliseconds:

1. The rotary solenoid is disengaged from the relay shaft after it is used to electrically reset the device. This reduces the drag on the relay shaft enabling the high-speed TRIP. The handle always resets in the vertical position. Therefore, it is not used as a position indicator. It is used only to reset the LOR/ER or LOR/SR manually. The Target is the position indication.
2. The mechanical target indexes to TRIP (Orange) when the LOR/ER or LOR/SR trips but does not reset (to Black) when the LOR/ER or LOR/SR is electrically reset. The target is reset manually with a lever on the face of the nameplate. This enables a station operator to observe and record the fact that the LOR/ER or LOR/SR did TRIP – a much less expensive method than using recorders.

VERIFICATION TESTING

The Series 24 LOR, LOR/ER, and LOR/SR Lock-out Relays have been tested to many different service conditions to insure that they will operate satisfactorily as general devices -- not special use. For power industry applications the testing is performed in accordance with the following standards:

- ANSI/IEEE-323-1984
Qualifying Class IE Equipment for Nuclear Power Generating Stations
- ANSI/IEEE-344-1987
Recommended Practices for Seismic Qualification of Class IE Equipment for Nuclear Power Generating Stations
- ANSI/IEEE C37.90-1989
Relays and Relay Systems Associated with Electric Power Apparatus
- ANSI/IEEE C37.98-1987
Seismic Testing of Relays

The testing is performed in accordance with ESC-STD-1000 - General Specifications for Rotary Switches and Auxiliary Relays for Utility Applications including IE Equipment Requirements for Nuclear Power Generating Stations. The tests include ratings evaluation tests, aging tests to simulate forty years operating life, and seismic tests.

Aging Tests

Aging tests are run in accordance with ANSI/IEEE 323-1984 and ESC-STD-1000 and consist of the following (run in sequence):

1. Visual and mechanical examination
2. Circuit configuration
3. Dielectric Withstanding Voltage-2200VRMS
4. Insulation resistance - 100 megohms minimum at 500 VDC
5. Contact resistance - 10 milliohms maximum at rated current
6. Radiation aging - 10 megarads (10^7)
7. Elevated temperature - 120 hours at 80°C
8. Elevated humidity - 96 hours at 95% RH
9. Temperature rise (contacts) – 50°C maximum
10. Aging – 10,000 cycles at 20A-120VAC and 3A-125VDC (both resistive)
11. Seismic vibration – ZPA = 5g
12. After test measurements (in order) – items 3,4,5,9,2,1

Details on the background of these tests, plus the methods and procedures are outlined in ESC-STD-1000.

Seismic Tests

The Series 24 LOR, LOR/ER, and LOR/SR Lock-out Relays are subjected to fragility testing in a seismic environment after aging to an accelerated life estimated to be forty years. This sequence is outlined under Aging Tests. The seismic tests are in accordance with ANSI/IEEE 344-1987 and ANSI/IEEE C37.98-1987. The tests are performed in accordance with ESC-STD-1000. Broadband repeatable multi-frequency input motions are used. The Fragility Response Spectrum (FRS) envelopes the Standard Response Spectrum (SRS) shown in Fig. 18, using a biaxial input motion.

The “g” rating of the Lock-out Relays are defined as the ZPA (zero period acceleration). The “g” rating, then, is 5g. The Series 24 LOR and LOR/ER are tested in the normal RESET position, the TRIP position, and during transition from RESET to TRIP. The LOR/SR is tested in the RESET position.

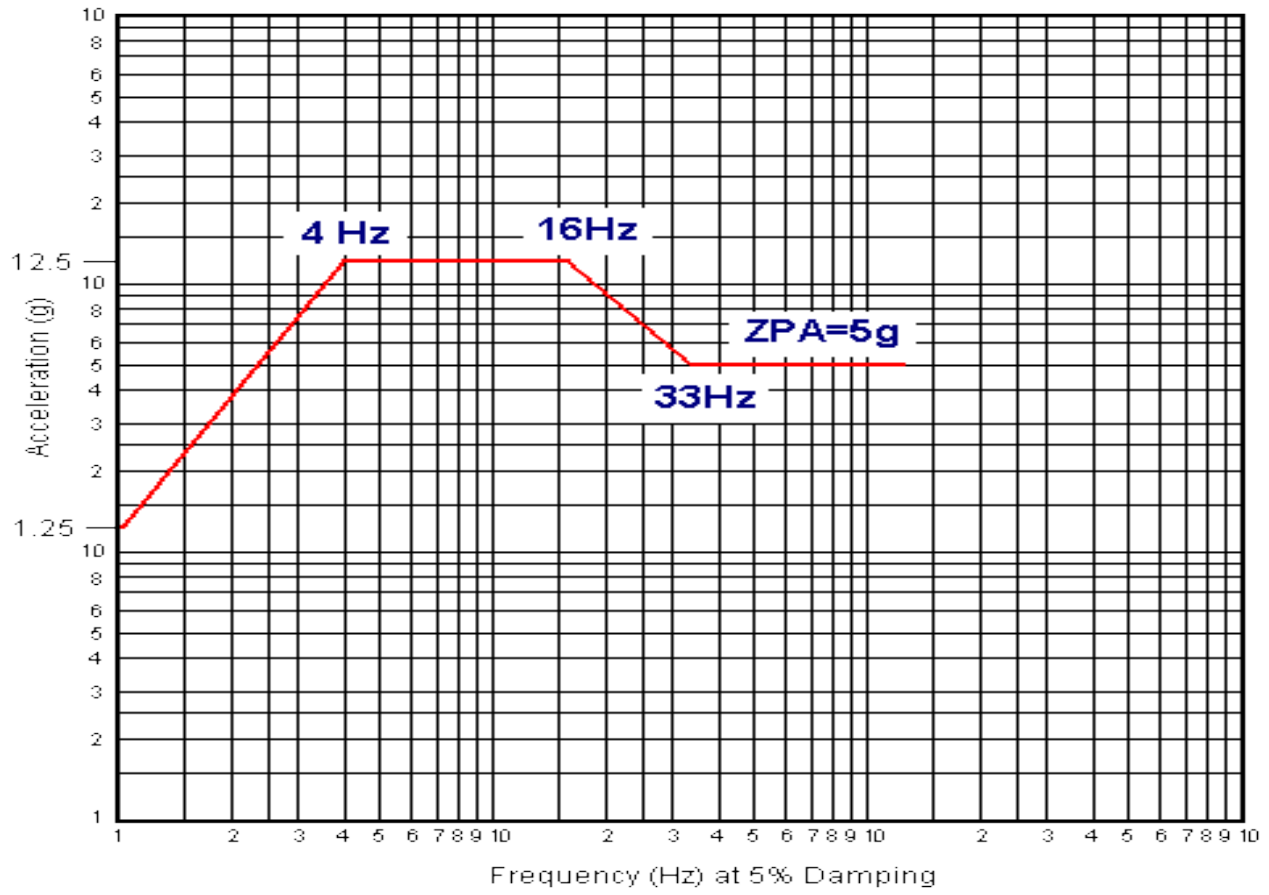

Fig. 18. Multi-frequency Broadband Standard Response Spectrum (SRS)

HOW TO ORDER LOCK-OUT RELAYS

1. Select desired trip-coil from data on pages 4 and 6.
2. Select reset coil voltage from chart below.
3. Choose appropriate catalog number below.
4. Units are supplied with engraved nameplate (code 17C-2L22) unless otherwise specified.
5. For other than standard relays shown below (or for your own documentation purposes) complete DESIGN GUIDE (shown on pages 12, 13, 14).

MANUAL-RESET LOR

DECKS	CATALOG NUMBERS with TRIP COILS								
	COIL A	COIL B	COIL C	COIL D	COIL E	COIL F	COIL G	COIL H	COIL K
3	7803A	7803B	7803C	7803D	7803E	7803F	7803G	7803H	7803K
5	7805A	7805B	7805C	7805D	7805E	7805F	7805G	7805H	7805K
8	7808A	7808B	7808C	7808D	7808E	7808F	7808G	7808H	7808K
10	7810A	7810B	7810C	7810D	7810E	7810F	7810G	7810H	7810K

STANDARD TRIP ELECTRIC-RESET LOR/ER

DECKS	RESET COIL VOLTAGE	CATALOG NUMBERS with TRIP COILS								
		COIL A	COIL B	COIL C	COIL D	COIL E	COIL F	COIL G	COIL H	COIL K
3	24 VDC	7823AA	7823BA	7823CA	7823DA	7823EA	7823FA	--	--	7823KA
5	24 VDC	7825AA	7825BA	7825CA	7825DA	7825EA	7825FA	--	--	7825KA
8	24 VDC	7828AA	7828BA	7828CA	7828DA	7828EA	7828FA	--	--	7828KA
3	48 VDC	7823AC	7823BC	7823CC	7823DC	7823EC	7823FC	--	--	7823KC
5	48 VDC	7825AC	7825BC	7825CC	7825DC	7825EC	7825FC	--	--	7825KC
8	48 VDC	7828AC	7828BC	7828CC	7828DC	7828EC	7828FC	--	--	7828KC
3	125 VDC	7823AD	7823BD	7823CD	7823DD	7823ED	7823FD	7823GD	--	7823KD
5	125 VDC	7825AD	7825BD	7825CD	7825DD	7825ED	7825FD	7825GD	--	7825KD
8	125 VDC	7828AD	7828BD	7828CD	7828DD	7828ED	7828FD	7828GD	--	7828KD
3	250 VDC	7823AF	7823BF	7823CF	7823DF	7823EF	7823FF	--	7823HF	7823KF
5	250 VDC	7825AF	7825BF	7825CF	7825DF	7825EF	7825FF	--	7825HF	7825KF
8	250 VDC	7828AF	7828BF	7828CF	7828DF	7828EF	7828FF	--	7828HF	7828KF

HIGH-SPEED TRIP, ELECTRIC-RESET LOR/ER

DECKS	RESET COIL VOLTAGE	CATALOG NUMBERS with TRIP COILS		
		COIL D	COIL E	COIL F
3	125 VDC	7833DD	7833ED	7833FD
5	125 VDC	7835DD	7835ED	7835FD
8	125 VDC	7838DD	7838ED	7838FD
10	125 VDC	7840DD	7840ED	7840FD
3	250 VDC	7833DF	7833EF	7833FF
5	250 VDC	7835DF	7835EF	7835FF
8	250 VDC	7838DF	7838EF	7838FF
10	250 VDC	7840DF	7840EF	7840FF

STANDARD TRIP, INSTANT-RESET, SELF-RESET LOR/SR

DECKS	RESET COIL VOLTAGE	CATALOG NUMBERS with TRIP COILS			
		COIL D	COIL E	COIL F	COIL G
3	125 VDC	7843DD	7843ED	7843FD	7843GD
5	125 VDC	7845DD	7845ED	7845FD	7845GD
8	125 VDC	7848DD	7848ED	7848FD	7848GD

STANDARD TRIP, TIME-DELAY RESET, SELF-RESET LOR/SR

DECKS	RESET COIL VOLTAGE	CATALOG NUMBERS with TRIP COILS			
		COIL D	COIL E	COIL F	COIL G
3	125 VDC	7853DD	7853ED	7853FD	7853GD
5	125 VDC	7855DD	7855ED	7855FD	7855GD
7	125 VDC	7857DD	7857ED	7857FD	7827GD

HIGH-SPEED TRIP, INSTANT RESET, SELF-RESET LOR/SR

DECKS	RESET COIL VOLTAGE	CATALOG NUMBERS with TRIP COILS		
		COIL D	COIL E	COIL F
3	125 VDC	7863DD	7863ED	7863FD
5	125 VDC	7865DD	7865ED	7865FD
8	125 VDC	7868DD	7868ED	7868FD

HIGH-SPEED TRIP, TIME-DELAY RESET, SELF-RESET LOR/SR

DECKS	RESET COIL VOLTAGE	CATALOG NUMBERS with TRIP COILS		
		COIL D	COIL E	COIL F
3	125 VDC	7873DD	7873ED	7873FD
5	125 VDC	7875DD	7875ED	7875FD
7	125 VDC	7877DD	7877ED	7877FD



ELECTROSWITCH

Check out these other Great Products from the Electroswitch Family!

