

4.9 mm Square SMD Light Touch Switches

Type: **EVQPL/EVQ3PL**
EVQ5PL/EVQPT

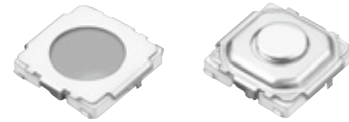

■ Features

- External dimensions : 4.9 mm×4.9 mm,
Height: 0.8 mm(Without push plate), 1.5 mm(With push plate)

■ Recommended Applications

- Operation switches for portable electronic equipment
(Notebook PC, Camcorders, Portable audio players, etc.)
- Operation switches for car audio systems

■ Explanation of Part Numbers

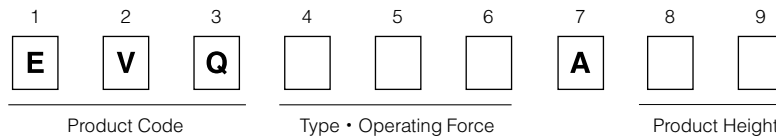

■ Specifications

Type		Snap action/Push-on type SPST	
Electrical	Rating	10 μ A 2 V DC to 20 mA 15 V DC (Resistive load)	
	Contact Resistance	50 m Ω max.	
	Insulation Resistance	50 M Ω min. (at 100 V DC)	
	Dielectric Withstanding Voltage	250 V AC for 1 minute	
	Bouncing	3 ms max. (ON) 8 ms max. (OFF)	
Mechanical	Operating Force	1.0 N \pm 0.5 N 1.6 N \pm 0.5 N	2.6 N \pm 0.6 N 3.5 N \pm 1.0 N
	Travel	0.25 mm ^{+0.10} / _{-0.20} mm	
Endurance	Operating Life	500,000 cycles min.	200,000 cycles min.
Operating Temperature		-20 °C to +70 °C	
Storage Temperature		-40 °C to +85 °C (Bulk) -20 °C to +60 °C (Taping)	
Minimum Quantity/Packing Unit		5,000 pcs. Embossed Taping (Reel Pack)	
Quantity/Carton		25,000 pcs.	

Note: Non washable

Design and specifications are each subject to change without notice. Ask factory for the current technical specifications before purchase and/or use.
Should a safety concern arise regarding this product, please be sure to contact us immediately.

■ Dimensions in mm (not to scale)

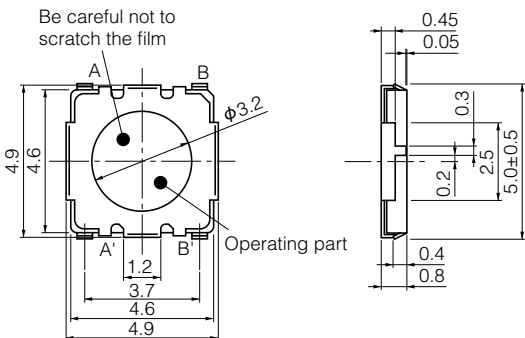
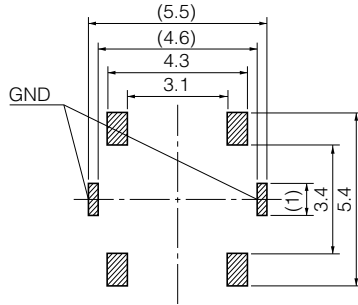
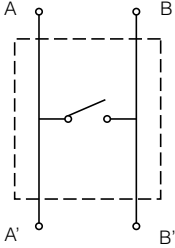
<p>No. 1</p> <p>EVQPLF EVQPLK EVQ5PL</p> <p>(Embossed Taping)</p> <p>Surface mount For reflow soldering Without push plate</p> 	<p>Be careful not to scratch the film</p>  <p>General dimension tolerance : ± 0.2 () dimensions are reference dimensions.</p>  <p>PWB land pattern for reference</p>  <p>Circuit diagram</p>
--	---

Part Numbers	Operating Force	Height	Operating Life
EVQPLFA08	1.6 N	0.8 mm	500,000 cycles
EVQPLKA08	2.6 N	0.8 mm	200,000 cycles
EVQ5PLA08	3.5 N	0.8 mm	200,000 cycles

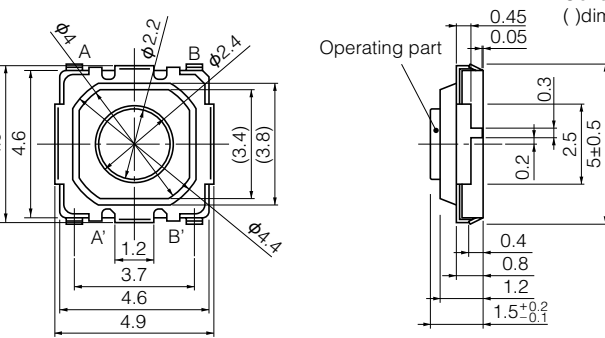
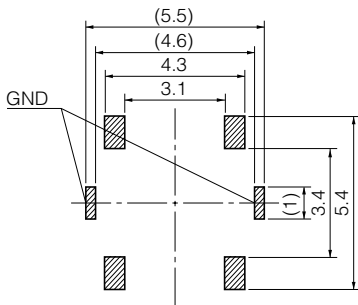
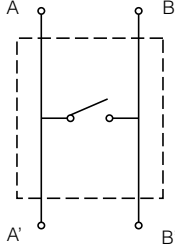
<p>No. 2</p> <p>EVQPLD/PT5 EVQPLH/PT9 EVQPLM EVQ3PL</p> <p>(Embossed Taping)</p> <p>Surface mount For reflow soldering With push plate</p> 	<p>General dimension tolerance : ± 0.2 () dimensions are reference dimensions.</p>  <p>Operating part</p>  <p>PWB land pattern for reference</p>  <p>Circuit diagram</p>
--	---

Part Numbers	Operating Force	Height	Operating Life
EVQPLDA15/PT5A15	1.0 N	1.5 mm	500,000/2,000,000 cycles
EVQPLHA15/PT9A15	1.6 N	1.5 mm	500,000/2,000,000 cycles
EVQPLMA15	2.6 N	1.5 mm	200,000 cycles
EVQ3PLA15	3.5 N	1.5 mm	200,000 cycles

Design and specifications are each subject to change without notice. Ask factory for the current technical specifications before purchase and/or use.
Should a safety concern arise regarding this product, please be sure to contact us immediately.

■ Recommended Reflow Soldering Conditions

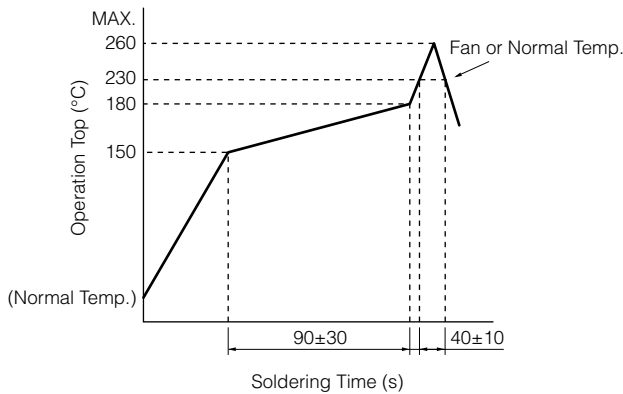

● Embossed Carrier Taping

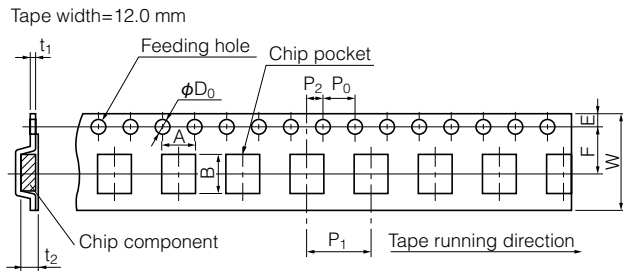

Taping condition : Lack of products in the middle of taping should be one MAX, but total quantity specified in the specifications should be secured.
 Peeling off strength of top tape : It should be within 0.2N to 1.0N at 165 degree in peeling off angle.
 Joint of carrier tape : One joint per one reel may exist.

Unit: mm

Part No.	Height	A	B	W	F	E	P ₁	P ₂	P ₀	D ₀ Dia.	t ₁	t ₂
EVQPL EVQ3PL EVQ5PL EVQPT	0.8/1.5	5.0±0.2	5.0±0.2	12.0±0.3	5.5±0.1	1.75±0.10	8.0±0.1	2.0±0.1	4.0±0.1	1.5 ^{+0.1} ₀	0.35±0.1	1.0/1.7±0.2

■ Recommended Shape of Test Pole

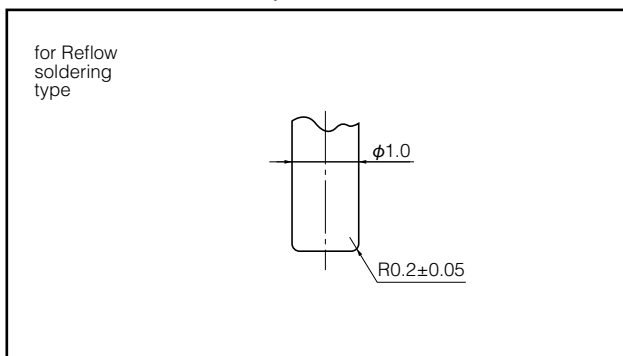

■ Recommended Operating Conditions

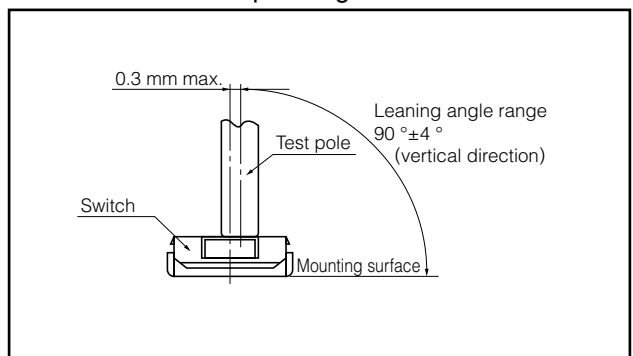

Design and specifications are each subject to change without notice. Ask factory for the current technical specifications before purchase and/or use.
 Should a safety concern arise regarding this product, please be sure to contact us immediately.

Requests to customers

Please refer to "the latest product specifications" when designing your product.

Requests to customers :

<https://industrial.panasonic.com/ac/e/salespolicies/>

Safety Precautions

When using our products, no matter what sort of equipment they might be used for, be sure to confirm the applications and environmental conditions with our specifications in advance.

Please contact

Panasonic Corporation

Electromechanical Control Business Division

■ 1006, Oaza Kadoma, Kadoma-shi, Osaka 571-8506, Japan
industrial.panasonic.com/ac/e/

Panasonic[®]

©Panasonic Corporation 2019