



**PARA LIGHT ELECTRONICS CO., LTD.**

4F, No.1, Lane 93, Chien Yi Road, Chung Ho City, Taipei, Taiwan  
Tel: 886-2-2225-3733 Fax: 886-2-2225-4800  
E-mail: [para@para.com.tw](mailto:para@para.com.tw) <http://www.para.com.tw>

**DATA SHEET**

**PART NO. : PL0703-CW107-Q-S1**

**REV : A/1**

CUSTOMER'S APPROVAL : \_\_\_\_\_ DCC : \_\_\_\_\_

●Package Dimension

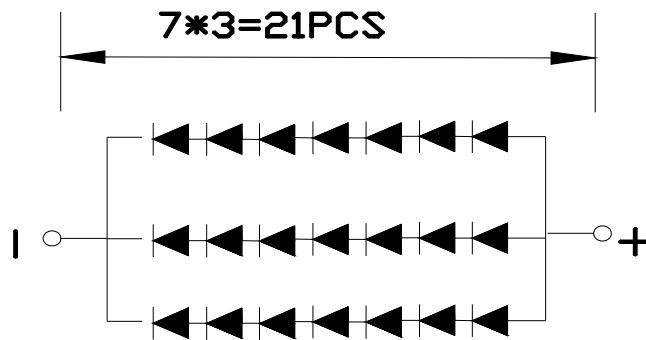
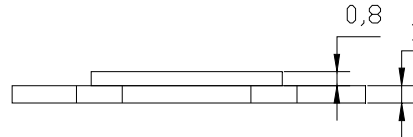
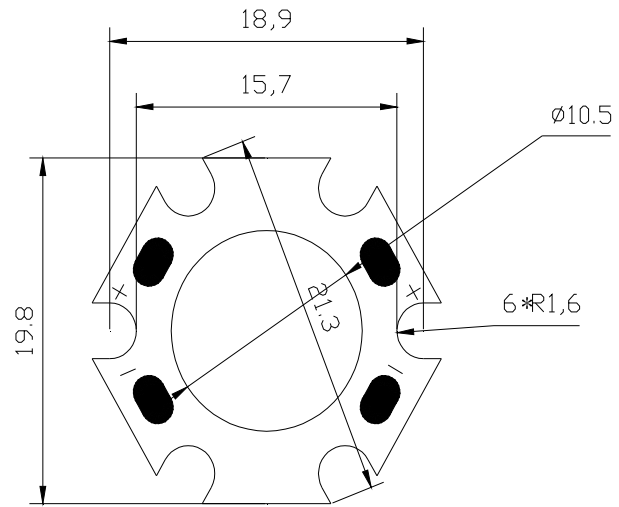

Note:

1. All dimensions are in millimeters.
2. Tolerance is  $\pm 0.2\text{mm}$  (.010") unless otherwise noted

●Features

1. Uniform high quality illumination
2. Streamlined thermal path
3. Compact high flux density light source
4. Low voltage DC operated.
5. Instant light
6. RoHS Compliant.
7. The led can withstand the max static level when assembling or operation (HBM)



## COB LED

PL0703-CW107-Q-S1

REV:A/1

### ●Chip Material

1. Dice Material : InGaN
2. Light Color : White

### ●Absolute Maximum Rating(Ta=25°C)

Symbol	Parameter	Rating	Unit
IF	DC Forward Current	350	mA
Tj	LED Junction Temperature(at IF=350mA)	120	°C
*Topr	Operating Temperature	-20 ~ +80	°C
*Tstg	Storage Temperature	-30 ~ +80	°C
ESD	ESD Sensitivity (Human Body Model)	2000	V

Note : Temperature for using with aluminum board.

### ●Electro-Optical Characteristic(Ta=25°C)

Parameter	Symbol	Min.	Typ.	Max.	Unit	Test Condition
Luminous Flux	$\Phi$		790		lm	IF=350mA
Viewing Angle	2 $\theta$ 1/2		130		deg	
Color Temperature	CCT		6000		K	IF=350mA
Forward Voltage	VF		22	25	V	IF =350mA
Power Dissipation	P		7.0		W	IF =350mA
Lumimous efficacy	$\eta$		100		Lm/W	IF =350mA
Color Rending Index	CRI	80			Ra	IF=350mA

•Typical Optical and Electrical

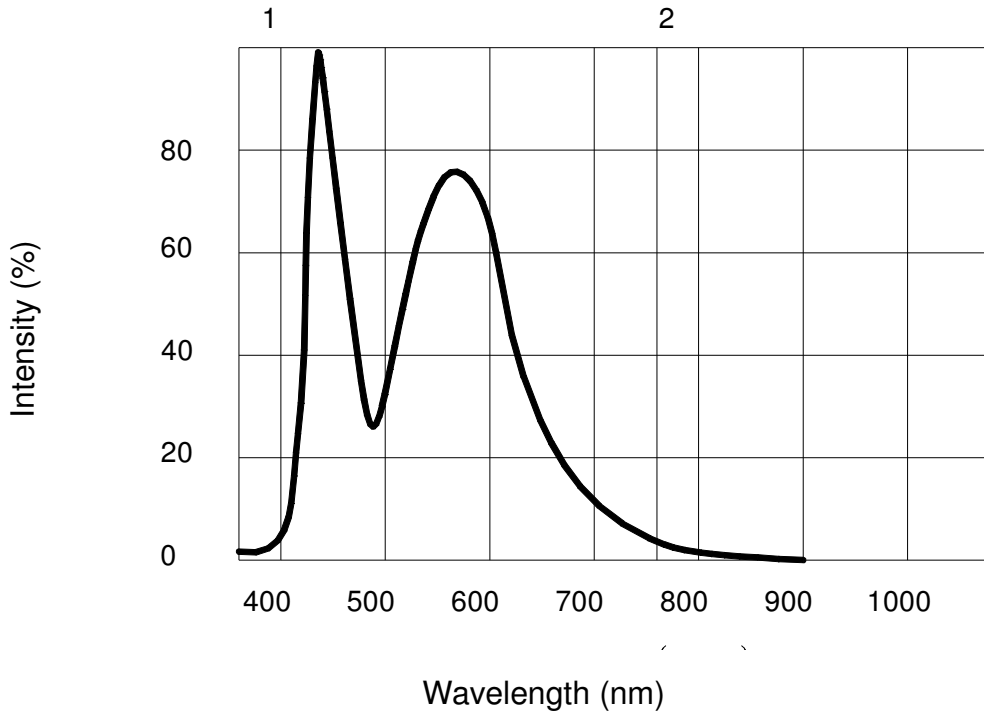

Relative Intensity VS Wavelength

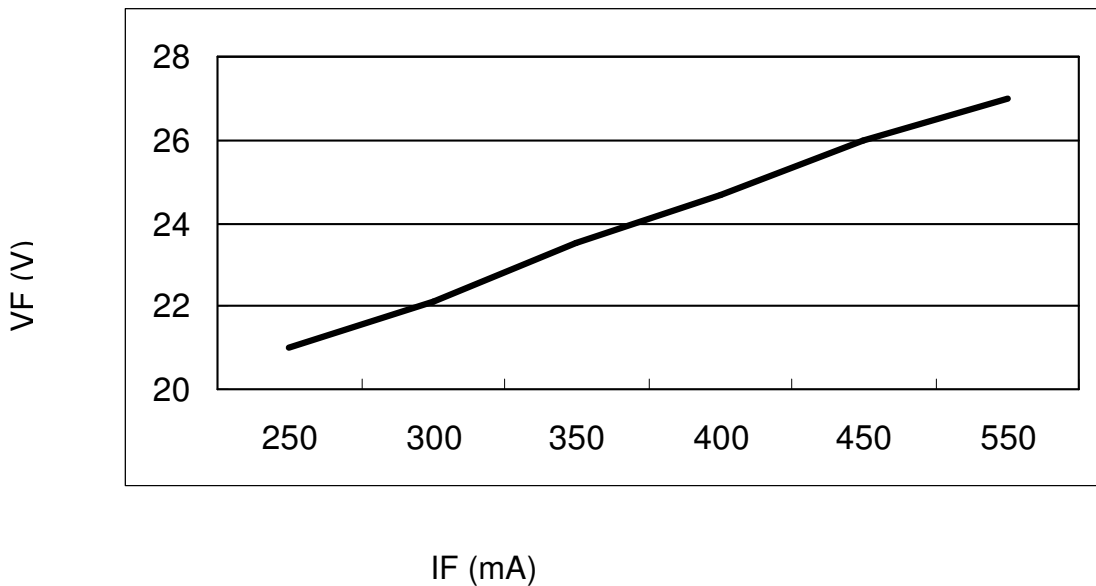

Forward Current VS Forward Voltage

●Typical Optical and Electrical

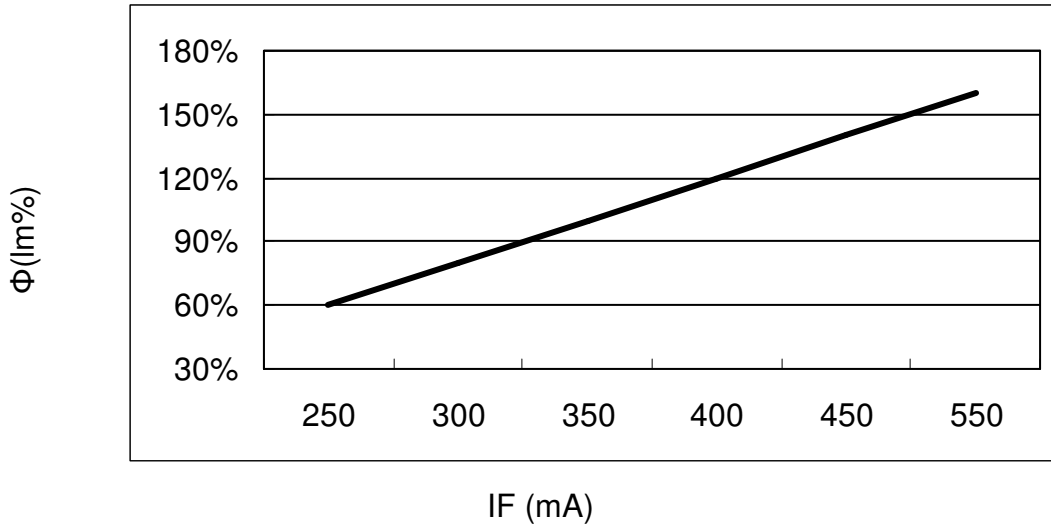

Forward Current VS Luminous Flux%

●Photometric Output vs.Board Temperature(If=350mA)

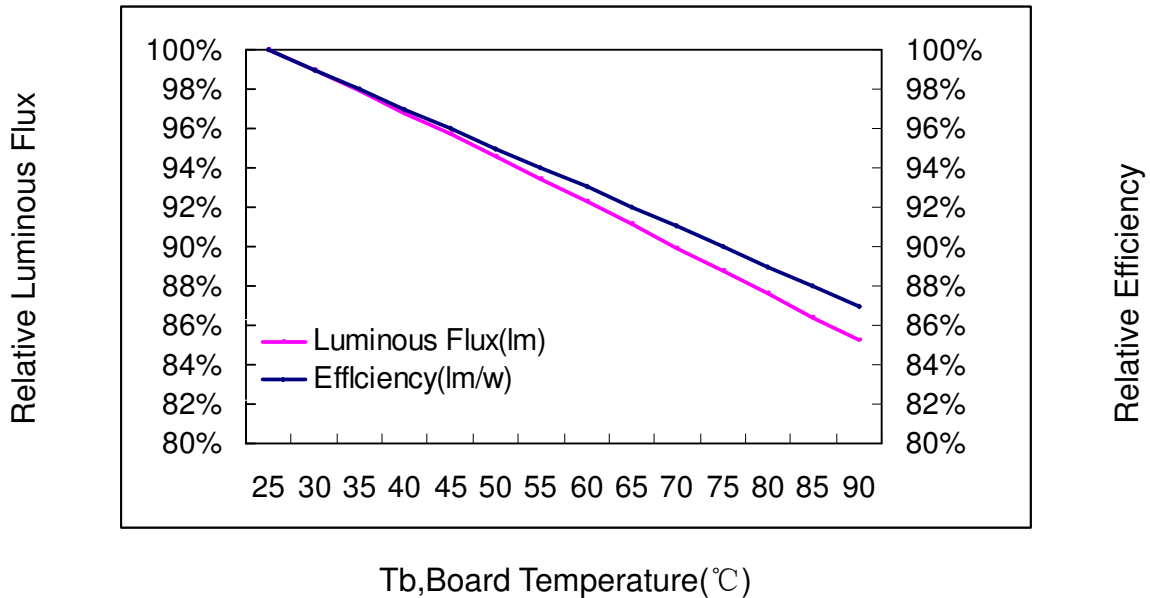

Cool—white Bin Table

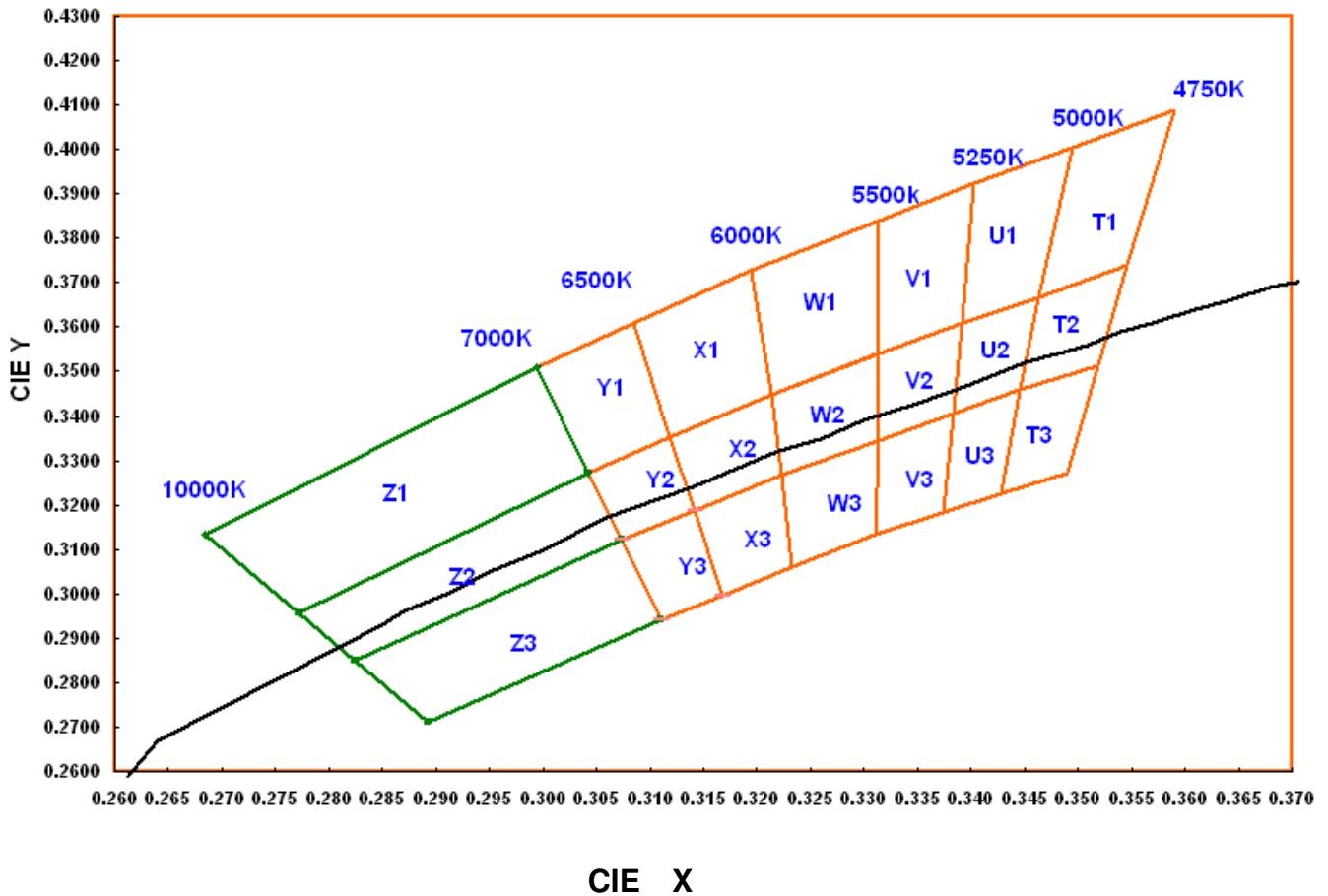

Cool—white Bin Structure



# COB LED

PL0703-CW107-Q-S1

REV:A/1

## COROMATICITY COORDINATE (CIE1931\_XY)

BIN Code	Chromaticity Coordinate (CIE1931-XY)							
	X1	Y1	X2	Y2	X3	Y3	X4	Y4
T1	0.3590	0.4088	0.3546	0.3741	0.3463	0.3667	0.3495	0.4005
T2	0.3546	0.3741	0.3518	0.3513	0.3446	0.3458	0.3463	0.3667
T3	0.3518	0.3513	0.3490	0.3272	0.3428	0.3227	0.3446	0.3458
U1	0.3495	0.4005	0.3463	0.3667	0.3392	0.3608	0.3403	0.3924
U2	0.3463	0.3667	0.3446	0.3458	0.3383	0.3406	0.3392	0.3608
U3	0.3446	0.3458	0.3428	0.3227	0.3374	0.3184	0.3383	0.3406
V1	0.3403	0.3924	0.3392	0.3608	0.3313	0.3540	0.3313	0.3841
V2	0.3392	0.3608	0.3383	0.3406	0.3313	0.3346	0.3313	0.3540
V3	0.3383	0.3406	0.3374	0.3184	0.3311	0.3132	0.3313	0.3346
W1	0.3313	0.3841	0.3312	0.3540	0.3213	0.3448	0.3195	0.3730
W2	0.3313	0.3540	0.3313	0.3346	0.3223	0.3266	0.3213	0.3448
W3	0.3313	0.3346	0.3311	0.3132	0.3232	0.3061	0.3223	0.3266
X1	0.3195	0.3730	0.3213	0.3448	0.3119	0.3354	0.3085	0.3610
X2	0.3213	0.3448	0.3223	0.3266	0.3142	0.3188	0.3119	0.3354
X3	0.3223	0.3266	0.3232	0.3061	0.3167	0.2997	0.3142	0.3188
Y1	0.3085	0.3610	0.3119	0.3354	0.3042	0.3270	0.2995	0.3510
Y2	0.3119	0.3354	0.3142	0.3188	0.3073	0.3120	0.3042	0.3270
Y3	0.3142	0.3188	0.3167	0.2997	0.3110	0.2941	0.3073	0.3120
Z1	0.2995	0.3510	0.3042	0.3270	0.2772	0.2955	0.2685	0.3135
Z2	0.3042	0.3270	0.3073	0.3120	0.2824	0.2850	0.2772	0.2955
Z3	0.3073	0.3120	0.3110	0.2941	0.2892	0.2713	0.2824	0.2850

**Typical Optical and Electrical**

**Typical polar radiation pattern for lambertion**

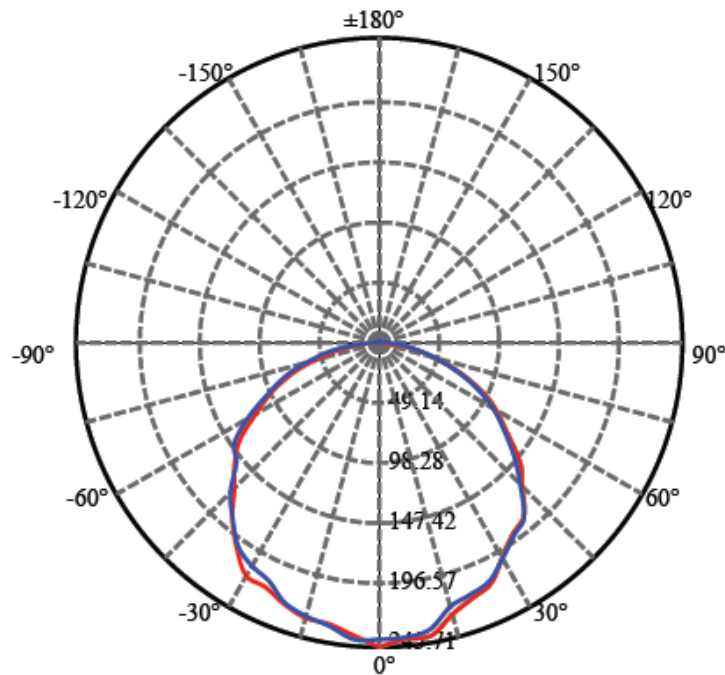

**●Bin Code List**

Luminous Flux ( $\Phi$ ),(Unit: lm ,IF=350mA)		
Bin Code	Min	Max
R	660	740
S	740	860

Including test tolerance  $\pm 10\%$

Forward Voltage(VF),(Unit: V, IF=350mA)		
Bin Code	Min	Max
V8	21	23
V9	23	25

Including test tolerance $\pm 0.1V$



●Label Explanation

P/N:	PL0703-CW107-Q-S1
LOT NO:	EMSL14090003
BIN NO:	S/5700-5900/V3
QTY:	XXXX PCS

PART NO: PL0703-CW107-Q-S1

LOT NO: EM S L 14 09 0003  
A B C D E F

- A---EM: EMOS
- B--S: SMD
- C—L: pay taxes
- D--- Year
- E--- Month
- F--- For series number

BIN NO: Bin Code

●Caution

(1).Handling note: Do not touch LED's surface.

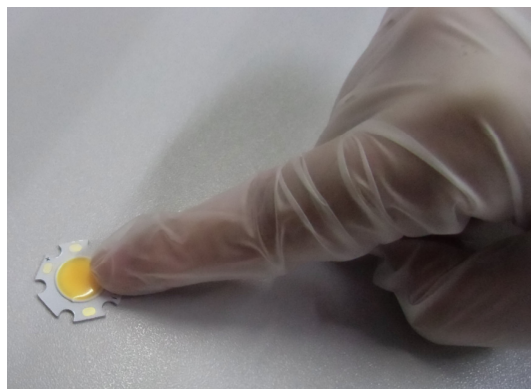
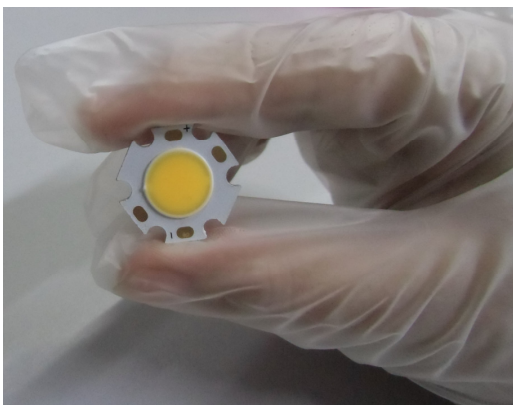

(2) Please wear anti-static wrist strap and gloves to prevent ESD damage when handling.



### ●Packing Specification

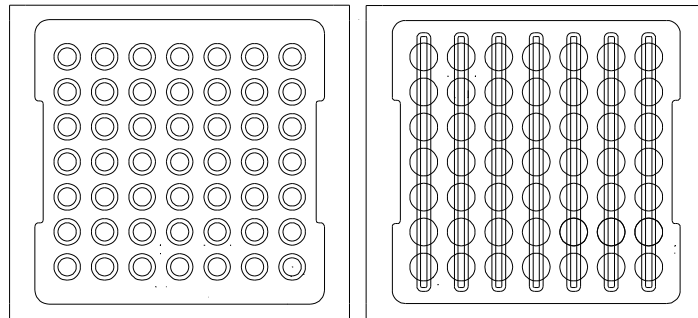

Carton A (1 pcs  $\times$  49 = 49 pcs )

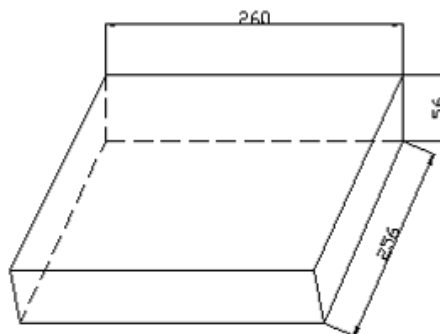

Carton B (49 pcs  $\times$  2 = 98 pcs)

#### Note:

1. All dimensions are in millimeters.
2. Normal packing Quantity 49 pcs.
3. The carton B contains 2 cartons A at maximum

**●Storage**

1. Do not open the moisture proof bag before the devices are ready to use.
2. Before the package is opened, LED should be stored at temperatures less than 30°C and humidity less than 50%.
3. LED may be stored for 6 months. When the storage time has reached more than 6 months, LED should be stored in a sealed container filled with Nitrogen gas.
4. After the package is opened, LED should be stored at temperatures less than 30°C and humidity less than 30%.
5. LED should be used within 168 hours (7 days) after the package is opened.

**●LED Operating Procedure**

1. LED 07W series products should be operated at 350 mA for ideal performance, but not more than 400 mA.
2. LED 07 W series products are sensitive to static. Operators must wear static wristband (wireless static wristband is prohibited) and be well grounded while working in the environment with an ionizing air blower. Anti-static requirement should be under ESD 2000V.
3. Sufficient thermal management must be applied. Large LED forward current will cause high junction temperature and reduce LED life.
4. Recommended Assembly Method is shown in Figure 1, LED 07W series products must be used in conjunction with heat-sinking devices and a thin layer of thermal grease should be applied to the bottom surface of the LED source

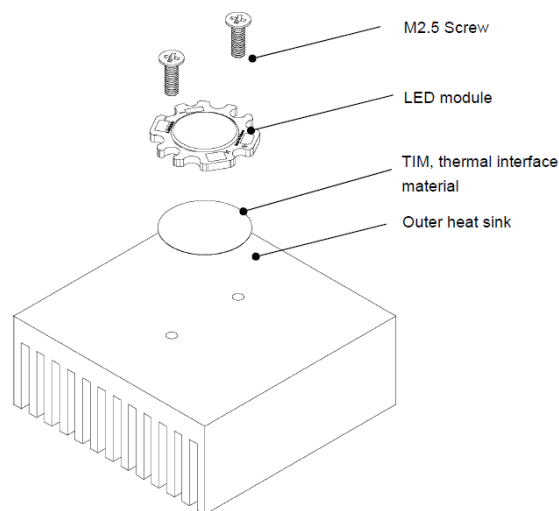

Figure 1

●Reliability Test

Test Item	number	Test Condition	Stress duration	result
High Temperature Storage Test	20pcs	100°C	1000hours	Pass
Low Temperature Storage Test	20pcs	-40°C	1000 hours	Pass
Room Temperature Operation	20pcs	Ta= 25°C IF =350mA	1000hours	Pass
Temperature Cycle	20pcs	H:+100°C 30mins L: -20°C 15mins	200 Cycles	Pass
High Temperature High Humidity Operation	20pcs	Ta=60°C RH= 85% IF=350mA	500 hours	Pass

With heat sink, in a good thermal-exchange surrounding.

Failure Criteria:

1. No catastrophic(LED fail)
2. Lumen maintenance >85%,
3. Change in Vf <10%.



COB LED

PL0703-CW107-Q-S1

REV:A/1

● Part NO. System of E-Power LED

PL 07 03 - CW1 07 - Q- S1

SN:  
S1: STAR type

Ra:  
N: 65-70    O: 70-75  
P: 75-80    Q: 80-85  
R: 85-90    S: 90-95

Power:  
03: 3W      20: 20W

CCT:  
WW1: 2580-3710K  
NW1: 3710-4745K  
CW1: 4745-6500K

Chip Qty in parallel

Chip Qty in series

PL- Aluminum panel  
PC- Ceramics panel  
PT- Copper panel