

# 5.0 mm DIA LED LAMP

L-5T47UW5C-D1-HV12

REV:A / 0

## PACKAGE DIMENSIONS

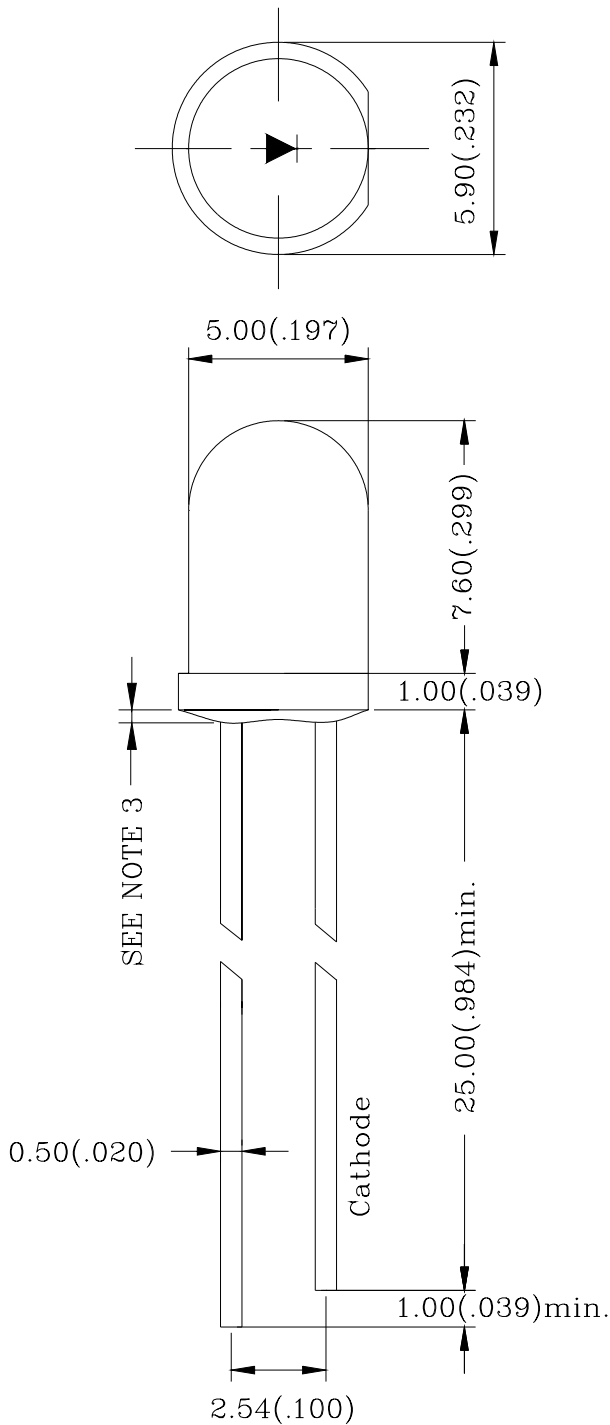

### Note:

- 1.All Dimensions are in millimeters.
- 2.Tolerance is  $\pm 0.25\text{mm}(0.010\text{ ''})$   
Unless otherwise specified.
- 3.Protruded resin under flange  
is 1.5mm(0.059 '' ) max.
- 4.Lead spacing is measured where  
the leads emerge from the package.
- 5.Specification are subject to change  
without notice
- 6.highlight  $<-500\text{V}$  the led can  
withstand the max static level when  
assembling or operation.

# 5.0 mm DIA LED LAMP

## L-5T47UW5C-D1-HV12

REV:A / 0

### FEATURES

- \* SUITABLE HIGH PULSE CURRENT OPERATION
- \* EXTRA HIGH RADIANT POWER AND RADIANT INTENSITY
- \* HIGH RELIABILITY
- \* LOW FORWARD VOLTAGE

### CHIP MATERIALS

- \* Dice Material : GaInN/GaN
- \* Light Color : ULTRA WHITE
- \* Lens Color : WATER CLEAR

### ABSOLUTE MAXIMUM RATING:(Ta=25°C)

SYMBOL	DESCRIPTION	ULTRA WHITE	UNIT
PAD	Power Dissipation Per Chip	480	mW
VR	Reverse Voltage Per Chip	5	V
IF	Average Forward Current Per Chip	30	mA
-	Derating Linear From 25°C Per Chip	0.4	mA/°C
Topr	Operating Temperature Range	-25°C to 85°C	
Tstg	Storage Temperature Range	-40°C to 85°C	
Lead Soldering Temperature { 1.6mm(0.063 inch) From Body } 260°C±5°C For 5 Seconds			

### ELECTRO-OPTICAL CHARACTERISTICS:(Ta=25°C)

SYMBOL	DESCRIPTION	TEST CONDITION	MIN.	TYP.	MAX.	UNIT
VF	Forward Voltage	IF = 10mA	10	12	16	V
IR	Reverse Current	VR = 5V			100	µA
2θ1/2	Half Intensity Angle	IF = 10mA		18		deg
IV	Luminous Intensity	IF = 10mA	-	2000	-	mcd
X	Chromaticity Coordinates	IF = 10mA		0.29		
Y		IF = 10mA		0.30		

# 5.0 mm DIA LED LAMP

## L-5T47UW5C-D1-HV12

REV:A / 0

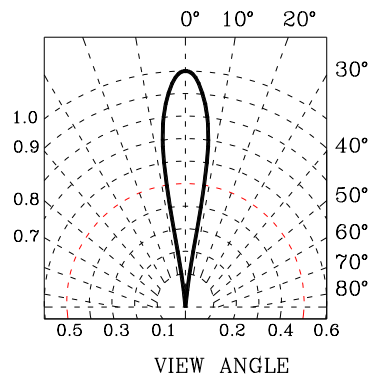
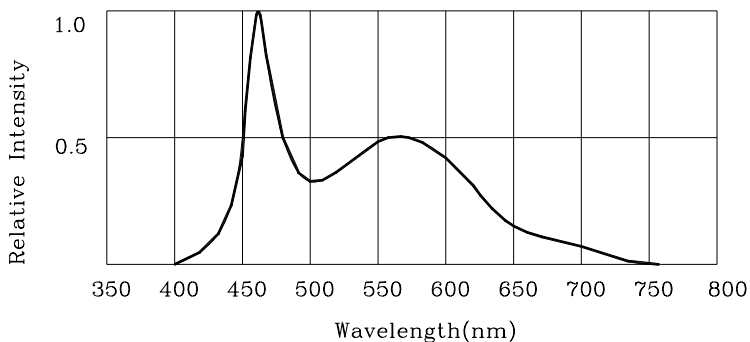
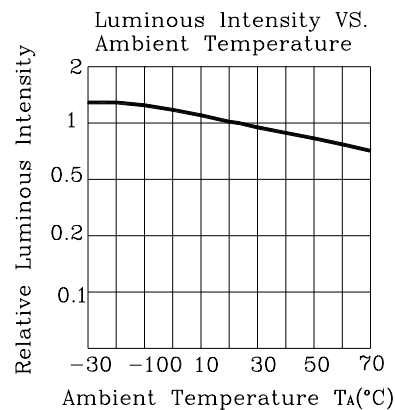
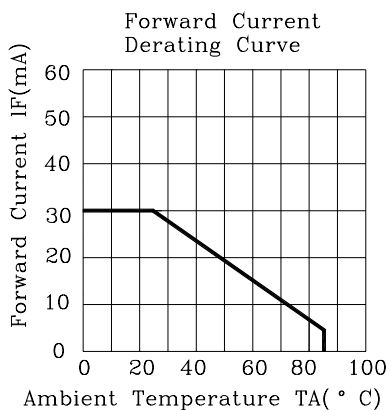
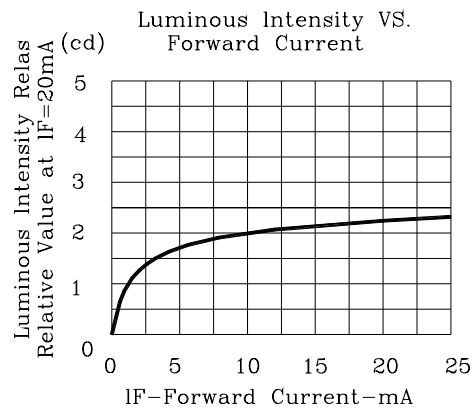
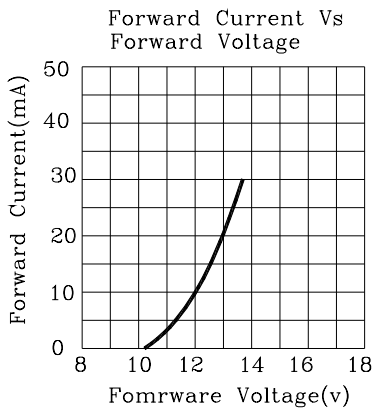

# 5.0 mm DIA LED LAMP

L-5T47UW5C-D1-HV12

REV:A / 0

## •SOLDERING

METHOD	SOLDERING CONDITIONS	REMARK
DIP SOLDERING	Bath temperature: 260±5°C Immersion time: with 5 sec	<ul style="list-style-type: none"> <li>• Solder no closer than 3mm from the base of the package</li> <li>• Using soldering flux, "RESIN FLUX" is recommended.</li> </ul>
SOLDERING IRON	Soldering iron: 30W or smaller Temperature at tip of iron: 260°C or lower Soldering time: within 5 sec.	<ul style="list-style-type: none"> <li>• During soldering, take care not to press the tip of iron against the lead.</li> </ul> <p>(To prevent heat from being transferred directly to the lead, hold the lead with a pair of tweezers while soldering</p>

1) When soldering the lead of LED in a condition that the package is fixed with a panel (See FIG.1), be careful not to stress the leads with iron tip.

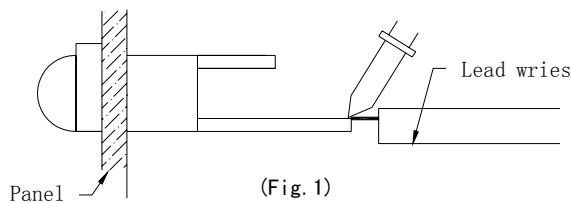

2) When soldering wire to the lead, work with a Fig (See Fig.2) to avoid stressing the package.

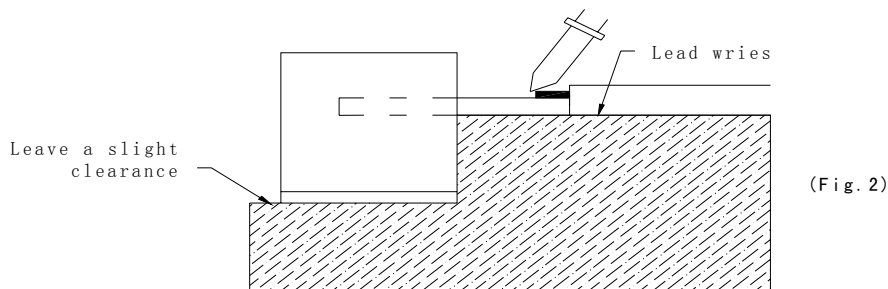

## 5.0 mm DIA LED LAMP

L-5T47UW5C-D1-HV12

REV:A / 0

- 3) Similarly, when a jig is used to solder the LED to PC board, take care as much as possible to avoid steering the leads (See Fig.3).

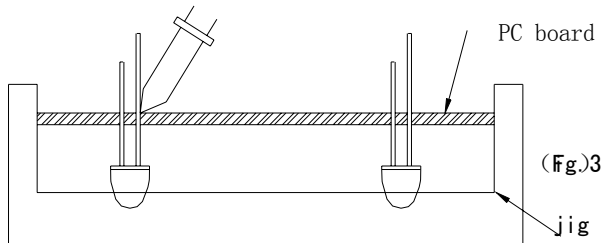

- 4) Repositioning after soldering should be avoided as much as possible. If inevitable, be sure to preserve the soldering conditions with irons stated above: select a best-suited method that assures the least stress to the LED.
- 5) Lead cutting after soldering should be performed only after the LED temperature has returned to normal temperature.

### ●LED MOUNTING METHOD

- 1) When mounting the LED by using a case, as shown Fig.4, ensure that the mounting holds on the PC board match the pitch of the leads correctly-tolerance of dimensions of the respective components including the LED should be taken into account especially when designing the case, PC board, etc. to prevent pitch misalignment between the leads and board holes, the diameter of the board holes should be slightly larger than the size of the lead. Alternatively, the shape of the holes should be made oval. (See Fig.4)

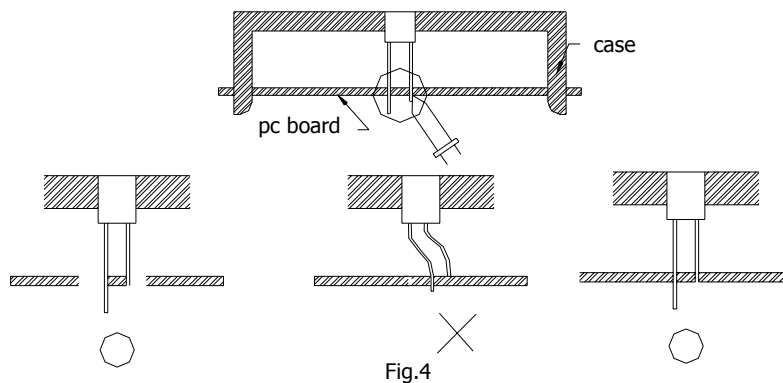

# 5.0 mm DIA LED LAMP

L-5T47UW5C-D1-HV12

REV:A / 0

2) Use LEDs with stand-off (Fig.5) or the tube or spacer made of resin (Fig.6) to position the LEDs.

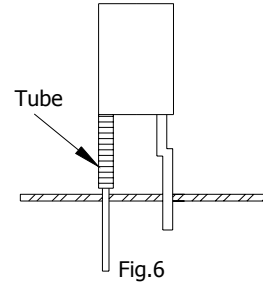
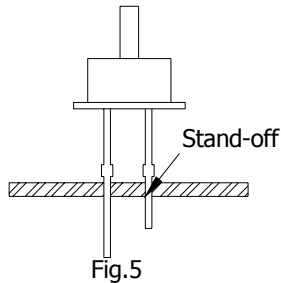

## ●FORMED LEAD

1) The lead should be bent at a point located at least 2mm away from the package. Bending should be performed with base fixed means of a jig or pliers (Fig.7)

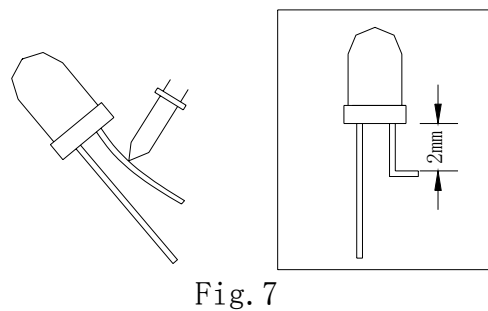

2) Forming lead should be carried out prior to soldering and never during or after soldering.

3) Form the lead of ensure alignment between the leads and the hole on board, so that stress against the LED is prevented. (Fig.8)

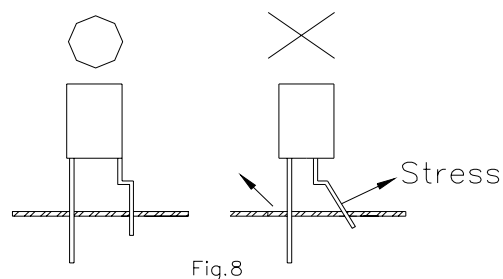

# 5.0 mm DIA LED LAMP

L-5T47UW5C-D1-HV12

REV:A / 0

## •LEAD STRENGTH

### 1) Bend strength

Do not bend the lead more than twice. (Fig.9)

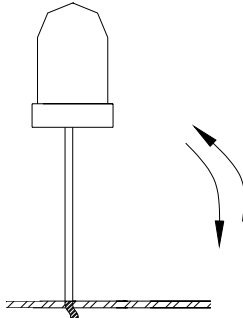

Fig.9

### 2) Tensile strength (@Room Temperature)

If the force is 1kg or less, there will be no problem. (Fig.10)

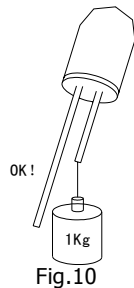

Fig.10

## •HANDLING PRECAUTIONS

Although rigid against vibration, the LEDs may be damaged or scratched if dropped. So take care when handling.

## •CHEMICAL RESISTANCE

- 1) Avoid exposure to chemicals as it may attack the LED surface and cause discoloration.
- 2) When washing is required, refer to the following table for the proper chemical to be used.  
(Immersion time: within 3 minutes at room temperature.)

SOLVENT	ADAPTABILITY
Freon TE	⊙
Chloroethene	×
Isopropyl Alcohol	⊙
Thinner	×
Acetone	×
Trichloroethylene	×

⊙--Usable    ×--Do not use.

NOTE: Influences of ultrasonic cleaning of the LED resin body differ depending on such factors as the oscillator output, size of the PC board and the way in which the LED is mounted. Therefore, ultrasonic cleaning should only be performed after confirming there is no problem by conducting a test under practical.

# 5.0 mm DIA LED LAMP

L-5T47UW5C-D1-HV12

REV:A / 0

## Experiment Item:

Item	Test Condition	Reference Standard
	Lamp & IR	
OPERATION LIFE	<p style="text-align: center;">Ta : 25±5°C</p> <p style="text-align: center;">IF= 20mA RH : ≤60%RH</p> <p>① DYNAMIC:100mA 1ms 1/10 duty</p> <p>② STATIC STATE: IF=20mA</p> <p style="text-align: center;">TEST TIME:</p> <p>168HRS (-24HRS , +24HRS)</p> <p>500HRS (-24HRS , +24HRS)</p> <p>1000HRS (-24HRS , +72HRS)</p>	<p>MIL-STD-750 : 1026</p> <p>MIL-STD-883 : 1005</p> <p>JIS C 7021 : B-1</p>
HIGH TEMPERATURE HIGH HUMIDITY STORAGE	<p style="text-align: center;">Ta : 65°C±5°C</p> <p style="text-align: center;">RH : 90~95%RH</p> <p style="text-align: center;">TEST TIME : 240HRS±2HRS</p>	<p>MIL-STD-202 : 103B</p> <p>JIS C 7021 : B-1</p>
TEMPERATURE CYCLING	<p style="text-align: center;">105°C ~ 25°C ~ -55°C ~ 25°C</p> <p style="text-align: center;">30min 5min 30min 5min</p> <p style="text-align: center;">10CYCLES</p>	<p>MIL-STD-202 : 107D</p> <p>MIL-STD-750 : 1051</p> <p>MIL-STD-883 : 1010</p> <p>JIS C 7021 : A-4</p>
THERMAL SHOCK	<p style="text-align: center;">105°C±5°C ~ -55°C±5°C</p> <p style="text-align: center;">10min 10min</p> <p style="text-align: center;">10CYCLES</p>	<p>MIL-STD-202 : 107D</p> <p>MIL-STD-750 : 1051</p> <p>MIL-SYD-883 : 1011</p>
SOLDER RESISTANCE	<p style="text-align: center;">T , sol : 260°C±5°C</p> <p style="text-align: center;">DWELL TIME : 10±1sec</p>	<p>MIL-STD-202 : 210A</p> <p>MIL-STD-750-2031</p> <p>JIS C 7021 : A-1</p>
SOLDERABILITY	<p style="text-align: center;">T , sol : 230°C±5°C</p> <p style="text-align: center;">DWELL TIME : 5±1sec</p>	<p>MIL-STD-202 : 208D</p> <p>MIL-STD-750 : 2026</p> <p>MIL-STD-883 : 2003</p> <p>JIS C 7021 : A-2</p>



# 5.0 mm DIA LED LAMP

L-5T47UW5C-D1-HV12

REV:A / 0

## PACKAGE

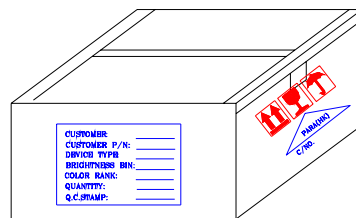
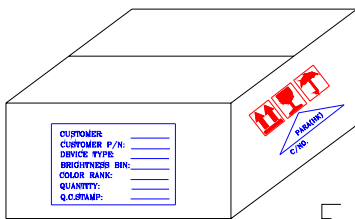
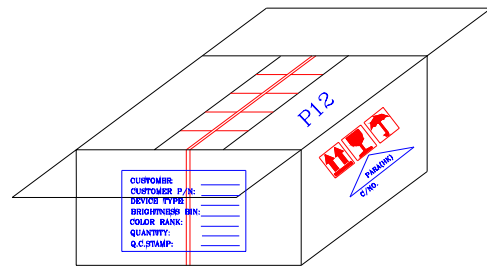
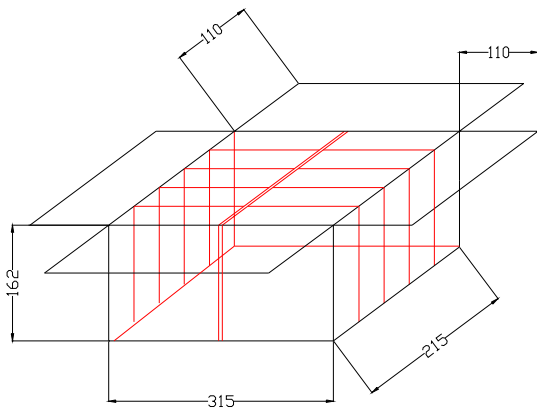
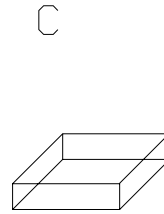
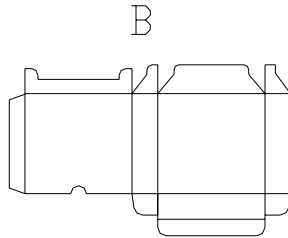
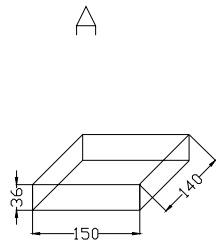

CUSTOMER	_____
CUSTOMER P/N:	_____
DEVICE TYPE:	_____
BRIGHTNESS BIN:	_____
COLOR RANK:	_____
QUANTITY:	_____
Q.C.STAMP:	_____



PARA(HK)

C/NO.

### Note:

1. All Dimensions are in millimeters.
2. Tolerance is  $\pm 10\text{mm}$  (0.394 ") Unless otherwise specified.
3. 500pcs/box A 5000pcs/box D