

# Type CR Case Resistors - 100 to 400 Watts

## APPLICATION

Powerohm's Type CR Case Resistors can be used in any AC or DC power circuit. Units are most commonly used for light-duty braking of variable frequency drives, space heating and any other low wattage load applications.

The Type CR resistors are suitable for intermittent and continuous duty applications requiring relatively high resistance and low wattage. The compact size of this unit makes it ideal for an installation where space is a premium. This unit can withstand extreme shock, qualifying it for nearly any high vibration application.

## BASIC CONSTRUCTION

Powerohm's Type CR resistors are manufactured with quality components for superior performance and increased life expectancy. Our case resistors feature a nickel-chromium wire helically wound, then placed inside a ceramic fixture and inserted into a corrosion resistant aluminum case. Each coil end is terminated to high temperature wire leads and encapsulated with a ceramic potting material. The result is a resistor element electrically isolated, but thermally bound to the outer case to allow the element heat to transfer to the metallic case and efficiently cool. The units are supplied with wire leads, and the case is machined to include two mounting holes for easy installation.

Our ceramic insulating cores are manufactured in-house to maintain total control over production and quality standards. Powerohm is the only domestic resistor manufacturer with this added advantage.

## OPTIONS

**CUSTOM SIZES:** Type CR resistors are normally available in (5) standard sizes with values between 100 to 400 watts per assembly. The overall size of the case determines the wattage rating and can be varied to meet specific ratings if necessary. Also, these units can be custom wound to any resistance value as long as it remains within the resistance ranges listed in the table on the following page.

**CUSTOM LEADS:** The standard lead length can be varied and the ends can be furnished with ring or fork terminals and male or female disconnects.

Type CR Case Resistor



## ELECTRICAL CHARACTERISTICS

**VOLTAGE INSULATION:** A standard Type CR resistor is insulated for up to 1000 volts maximum.

**RESISTANCE TOLERANCE:** + 10% for all units; as low as + 3% if required.

**COEFFICIENT OF RESISTIVITY:** Resistance values will increase as the element temperature rises. Expect an approximate increase of 5% in resistance after the unit reaches an operating temperature of 375°C above ambient. Contact the factory for more specific information if needed.

**AMBIENT TEMPERATURE:** Standard ratings are based on maximum ambient temperatures of 40°C. Derate wattage rating 90% for 50°C ambient, 80% for 80°C ambient and 70% for 100°C ambient.

**EFFECTS OF ALTITUDE:** The published electrical ratings are applicable for altitudes of 6000 feet or less. Contact the factory for deration factors above 6000 feet.

## CUSTOM DESIGNS

Powerohm offers a complete selection of standard size units. Numerous variations are available for almost any application. Please contact the factory if there are special service requirements, such as overloads, high peak currents, high ambient temperatures, etc.

# Type CR Electrical Ratings & Dimensions

**SPECIFY PART NUMBERS AS FOLLOWS:** CR - -

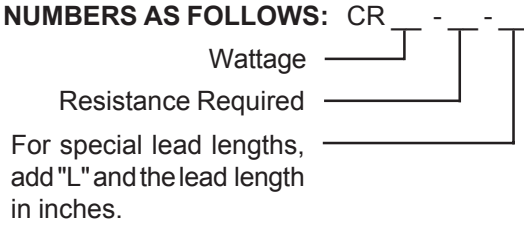

For example, the part number for a 100 watt, 20 ohm unit with standard 18 inch leads is CR100-20. The catalog number for the same resistor with a custom lead length of 36 inches is CR100-20-L36.

**RATINGS:** The continuous current ratings are based on a 375°C temperature rise. The resistance values are measured at 25°C and have a + 10% tolerance.

## ELECTRICAL RATINGS & DIMENSIONS OF STANDARD SIZE CASE RESISTORS

WATTAGE	RESISTANCE RANGE (OHMS)	DIMENSIONS IN INCHES				
		A	B	C	D	E
100	5 - 500	6	1-1/2	3/4	5-1/2	3/4
150	10 - 750	9	1-1/2	3/4	8-1/2	3/4
200	20 - 1000	6	3	1-1/2	5-1/2	1-1/2
300	30 - 1500	9	3	1-1/2	8-1/2	1-1/2
400	40 - 2000	12	3	1-1/2	11-1/2	1-1/2

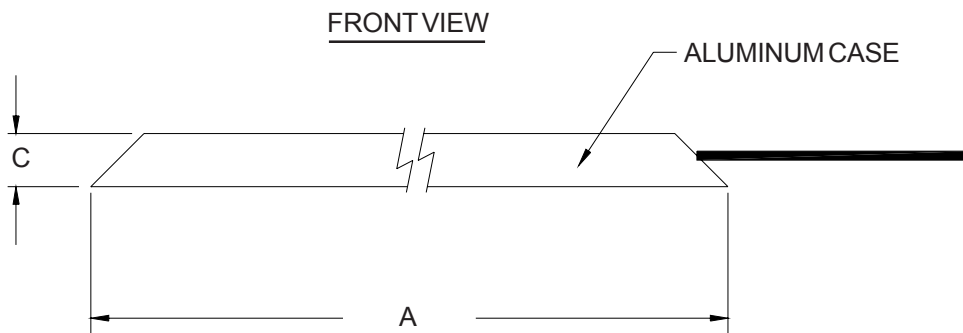
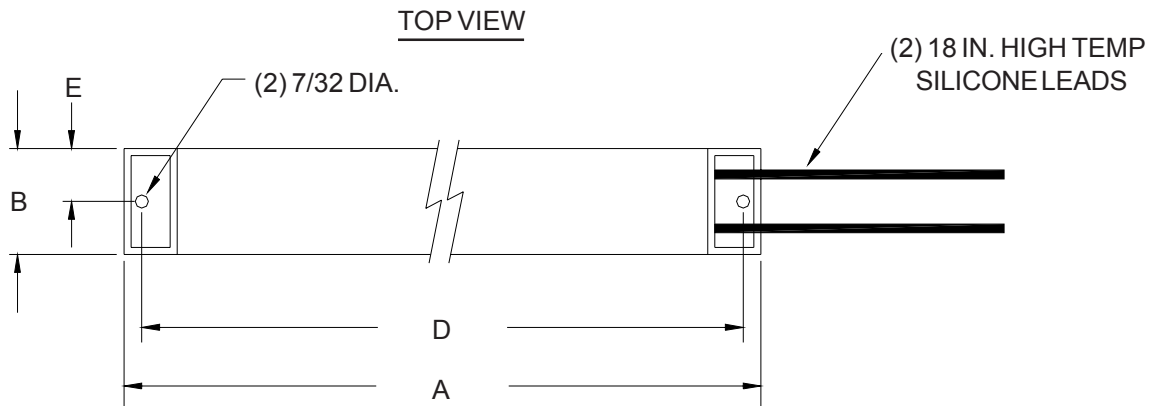

**24 HOUR EMERGENCY SERVICE**

**(800) 838-4694**

# Type SR & SXR Smoothwound Resistors-75 to 1050 Watts

## APPLICATION

Powerohm's Type SR & SXR Smoothwound Resistors can be used in any AC or DC power circuit. Units are most commonly used for light-duty braking of variable frequency drives, small horsepower motor control, space heaters and any low wattage, high resistance load application.

The Type SR & SXR resistors are suitable for continuous duty applications where high resistance and low current are required. These units are designed to withstand considerable shock, making them suitable for high vibration applications.

## BASIC CONSTRUCTION

High-quality components are used to manufacture Powerohm's Type SR and SXR resistors assuring long life and reliability. Our smoothwound resistors are durable units consisting of a low temperature coefficient resistance wire wound on a high-quality steatite tube. After fixed terminations are installed, the units are coated with a ceramic cement. The SR resistor has a special coating which contains a coarse sand. This special granular coating increases the surface area of the unit, yielding a much higher watt density per size than can be obtained using vitreous enamel or ordinary resistor cement.

Our ceramic insulating cores are manufactured in-house to maintain total control over production and quality standards. Powerohm is the only domestic resistor manufacturer with this added advantage.

## OPTIONS

**COIL SIZES:** Type SR & SXR resistors are available in (13) standard sizes. Wattage values vary from 75 to 1050 watts per coil. These units are custom wound to any resistance value required within the limits of the resistance range listed in the table on the following page.

**TERMINALS:** Multiple fixed, or adjustable terminals which slide along the element to any position on the coil, are available for all units.

**ENCLOSURES:** Powerohm Type SR & SXR Smoothwound Resistors can be mounted on brackets or in our standard selection of enclosures. See the enclosure section of our catalog for details, or contact the factory for assistance.



## ELECTRICAL CHARACTERISTICS

**VOLTAGE INSULATION:** A standard Type SR and SXR resistor is insulated for up to 600 volts maximum. End insulation can be added to increase this to 1000 volts. Standard enclosures can be insulated for voltages exceeding 1000 volts.

**RESISTANCE TOLERANCE:** + 10% for all units; + 3% if required.

**COEFFICIENT OF RESISTIVITY:** Resistance values will increase as the element temperature rises. Expect an approximate increase of 5% in resistance after the unit reaches an operating temperature of 375°C above ambient. Contact the factory for more specific information if needed.

**AMBIENT TEMPERATURE:** Standard ratings are based on maximum ambient temperatures of 40°C. Derate wattage rating 90% for 50°C ambient, 80% for 80°C ambient and 70% for 100°C ambient.

**EFFECTS OF ALTITUDE:** The published electrical ratings are applicable for altitudes of 6000 feet or less. Contact the factory for deration factors above 6000 feet.

## CUSTOM DESIGNS

Powerohm offers a complete selection of standard size coils. Each size coil has the same wattage rating and can be furnished with almost any desired resistance value. Numerous variations are available for almost any application. Please contact the factory if there are special service requirements, such as overloads, high peak currents, high ambient temperatures, etc.

# Type SR & SXR Electrical Ratings & Coil Dimensions

**SPECIFY PART NUMBERS AS FOLLOWS:** SR or SXR

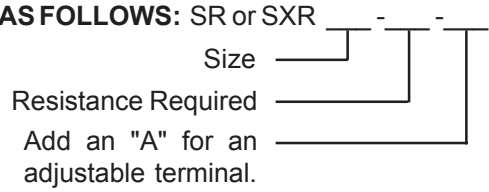

For example, the part number for a 200 watt, 100 ohm coil is SR5-100. The catalog number for the same coil with an adjustable terminal is SR5-100-A.

**RATINGS:** The continuous current ratings are based on a 375°C temperature rise. The resistance values are measured at 25°C and have a + 10% tolerance.

## TYPE SR ELECTRICAL RATINGS & DIMENSIONS OF STANDARD SIZE COILS

SIZE	WATTAGE	RESISTANCE RANGE (OHMS)	DIMENSIONS IN INCHES				
			A	B	C	D	E
3	75	2 - 1500	3	1-1/4	13/64	3/4	1/2
4	125	2 - 2500	4	1-1/4	13/64	3/4	1/2
5	200	3 - 5000	5-1/2	1-1/4	13/64	3/4	1/2
6	250	3 - 5000	6-1/2	1-1/4	13/64	3/4	1/2
7	300	3 - 5000	7-1/2	1-1/4	13/64	3/4	1/2
8	350	3 - 5000	8-1/2	1-1/4	13/64	3/4	1/2
10	450	4 - 7500	10-1/2	1-1/4	13/64	3/4	1/2

## TYPE SXR ELECTRICAL RATINGS & DIMENSIONS OF STANDARD SIZE COILS

SIZE	WATTAGE	RESISTANCE RANGE (OHMS)	DIMENSIONS IN INCHES				
			A	B	C	D	E
2	300	2 - 1500	6	2	7/32	1-1/8	3/4
3	450	2 - 2000	9	2	7/32	1-1/8	3/4
4	600	3 - 2500	12	2	7/32	1-1/8	3/4
5	750	4 - 3000	15	2	7/32	1-1/8	3/4
6	900	4 - 3500	18	2	7/32	1-1/8	3/4
7	1050	5 - 4000	21	2	7/32	1-1/8	3/4

FRONT VIEW

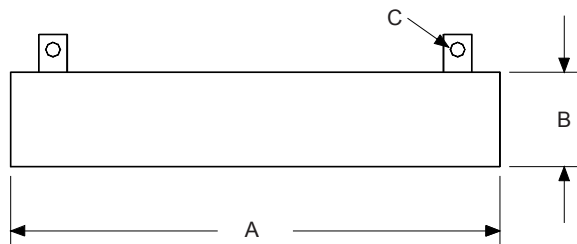

SIDE VIEW

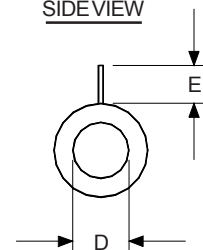

**24 HOUR EMERGENCY SERVICE**

**(800) 838-4694**

# Type VR Ventwound Resistors - 2.5 to 16.7 Amps

## APPLICATION

Powerohm's Type VR Ventwound Resistors can be used for any AC or DC power application. Units are most commonly used for braking of variable frequency drives, motor control, load banks and neutral grounding applications.

The Type VR resistors are suitable for continuous duty applications where low current and relatively high resistance are required. These units are designed to withstand continuous current ratings between 2.5 and 16.7 amps, and resistance values ranging between 170.0 and 1.0 ohms, respectively. Units have a rated temperature rise of 375°C above ambient temperature, which is in accordance with NEMA standards.

## BASIC CONSTRUCTION

Powerohm's Type VR resistors are lightweight, durable units consisting of a high quality stainless steel alloy wound around a toothed ceramic insulator. The element is attached at either end of the core by stainless steel terminals, or at various points for multiple connections. All resistors are supported by a threaded rod passing through the center of the ceramic core. These units include a ceramic insulator, fixed terminals, through rods, hardware and stainless steel element.

The Type VR resistor is an open-type design, which allows the element to come into direct contact with ambient air. This unique design allows for rapid, efficient cooling of the resistor element.

Our ceramic insulating cores are manufactured in-house to maintain total control over production and quality standards. Powerohm is the only domestic resistor manufacturer with this added advantage.

## OPTIONS

**COIL SIZES:** Type VR resistors are available in (6) standard lengths, all having the same approximate 2 inch diameter. Wattage values vary from 250 to 1100 watts per coil. These units are available in (17) different current ratings.

**ADJUSTABLE TERMINALS:** Adjustable terminals, which can be clamped to the element, are available for all units; add "-A" to the part number.

**ENCLOSURES:** Powerohm Type VR resistors can be packaged in our wide selection of enclosures. See the Enclosure Section of our catalog for details.

Type VR Ventwound Resistor



## ELECTRICAL CHARACTERISTICS

**VOLTAGE INSULATION:** A standard Type VR resistor is insulated for 1000 volts. Our standard bracket and enclosure assemblies are also insulated for 1000 volts. Also, with special precautions and additional insulation, units can be used for applications exceeding 15 kV.

**RESISTANCE TOLERANCE:** + 10% for all units; as low as + 3% if required.

**COEFFICIENT OF RESISTIVITY:** Resistance values will increase as the element temperature rises. Expect an approximate increase of 5% in resistance after the unit reaches an operating temperature of 375°C above ambient. Contact the factory for more specific information if needed.

**AMBIENT TEMPERATURE:** Standard ratings are based on maximum ambient temperatures of 40°C. Derate current rating 95% for 50°C ambient, 90% for 75°C ambient, and 85% for 100°C ambient.

**EFFECTS OF ALTITUDE:** The published electrical ratings are applicable for altitudes of 6000 feet or less. Contact the factory for deration factors above 6000 feet.

## CUSTOM DESIGNS

Powerohm offers a complete selection of standard size coils on the following page. These coils cover a wide range of resistance and current values. Numerous variations are available for special applications or replacement of other manufacturers. Powerohm can match the electrical ratings of any ventwound style product available. Please contact the factory for assistance.

# Type VR Electrical Ratings of Standard Size Coils

**SPECIFY PART NUMBERS AS FOLLOWS:** VR - .  
 Length ————  
 Amp Rating ————

For example, the part number of a 9.4 amp, 8.7 ohm coil is VR5-9.4.

**RATINGS:** The continuous current ratings are based on a 375°C temperature rise. The resistance values are measured at 25°C and have a + 10% tolerance.

## ELECTRICAL RATINGS OF STANDARD SIZE COILS

CONTINUOUS AMP RATING	RESISTANCE IN OHMS					
	LENGTH 2	LENGTH 3	LENGTH 4	LENGTH 5	LENGTH 6	LENGTH 7
16.7	1.0	1.6	2.2	2.7	3.3	3.9
14.9	1.2	2.0	2.7	3.4	4.2	4.9
13.3	1.6	2.5	3.4	4.3	5.3	6.2
11.9	2.0	3.1	4.3	5.5	6.7	7.9
10.6	2.5	4.0	5.5	7.0	8.5	9.9
9.4	3.1	5.0	6.9	8.7	10.6	12.5
8.4	3.9	6.3	8.6	11.0	13.3	15.7
7.3	5.0	8.0	11.1	14.1	17.1	20.1
6.5	6.4	10.2	14.0	17.8	21.6	25.5
5.9	7.9	12.6	17.3	22.0	26.7	31.4
5.2	9.9	15.9	21.9	27.8	34.0	40.0
4.5	13.3	21.2	29.2	37.0	45.0	53.0
4.1	16.7	26.7	37.0	47.0	57.0	67.0
3.6	21.2	34.0	47.0	60.0	72.0	85.0
3.2	26.6	42.0	59.0	75.0	90.0	107.0
2.8	34.0	54.0	74.0	94.0	114.0	135.0
2.5	43.0	68.0	93.0	120.0	144.0	170.0



# Type VR Coil Dimensions & Tap Options

## TYPE VR VENTWOUND DIMENSIONS

**COIL DIMENSIONS:** The coil dimensions are for standard size units. Coil and threaded rod length can be varied per customer request. All units have the same approximate diameter of 2 inches. Units are furnished with 5/16" through rods and #10 terminal hardware.

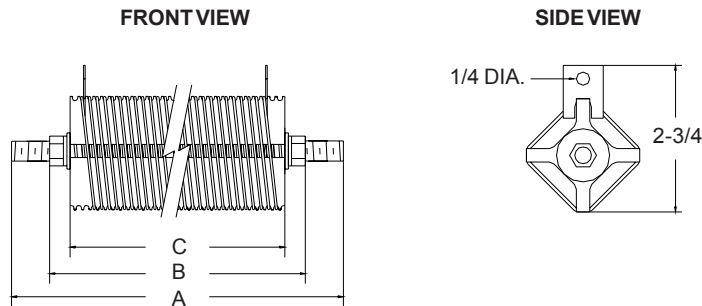

## STANDARD COIL DIMENSIONS

LENGTH	A	B	C
2	9-3/8	7	6-1/8
3	12-3/8	10	9-1/8
4	15-3/8	13	12-1/8
5	18-3/8	16	15-1/8
6	21-3/8	19	18-1/8
7	24-3/8	21	20-1/8

## ADDITIONAL TAPS

Type VR resistors are furnished with two stainless steel terminals at either end of the ceramic core. Additional fixed taps, welded in place at various intervals, are available for coils rated 7.3 amps and higher. Numerous tap configurations are available, but limited to a spacing no closer than 1 inch.

**SPECIFY PART NUMBERS AS FOLLOWS:**

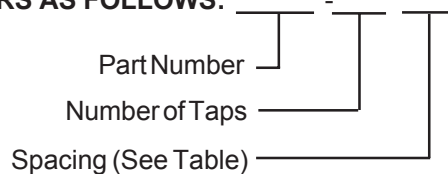

For example, the part number of a 9.4 amp, 8.7 ohm coil with 2 taps at 1/3 spacing is VR5-9.4-2C. See below for additional part number examples.

## ADDITIONAL TAPS & SPACING CHART

FRACTIONAL SPACING	SUFFIX LETTER
1/2	B
1/3	C
1/4	D
1/5	E
1/6	F
1/7	G
1/8	H
1/9	J
1/10	K
1/11	L
1/12	M
1/13	N
1/14	P
1/15	R
1/16	S
1/17	T
1/18	V
1/19	W
1/20	X
1/21	Z

Other part number examples of Type VR Ventwound Resistors with additional taps.

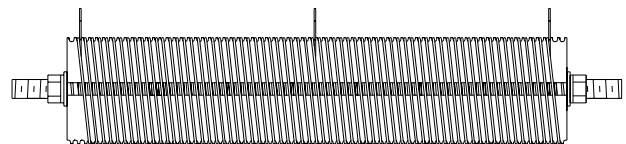

VR3-16.7-1B  
(1 TAP @ 1/2 SPACING)

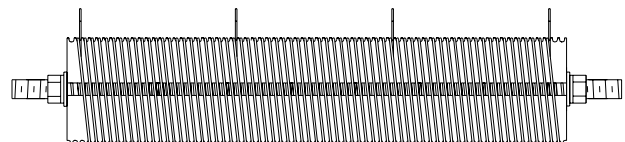

VR3-16.7-2C  
(2 TAP @ 1/3 SPACING)

# Type VR Mounting Bracket Options & Dimensions

Type VR Ventwound Resistors are available fully assembled on open-style brackets. This open-style construction consists of resistors installed on mill galvanized brackets complete with all stainless steel bus bars.

## SPECIFY PART NUMBERS AS FOLLOWS:

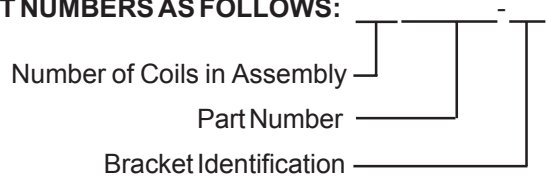

For example, the part number of a 9.4 amp, 8.7 ohm coil mounted on B1 Brackets is 1VR5-9.4-B1. Bracket assemblies consisting of 2 or more coils include series jumpers. Add "-N" to eliminate jumpers and "-P" for parallel jumpers.

## STANDARD BRACKET DIMENSIONS

DIMENSION	SIZE 2	SIZE 3	SIZE 4	SIZE 5	SIZE 6	SIZE 7
A	9	12	15	18	21	24
B	8	11	14	17	20	23

## B1 BRACKET ASSEMBLY OPTIONS & DIMENSIONS

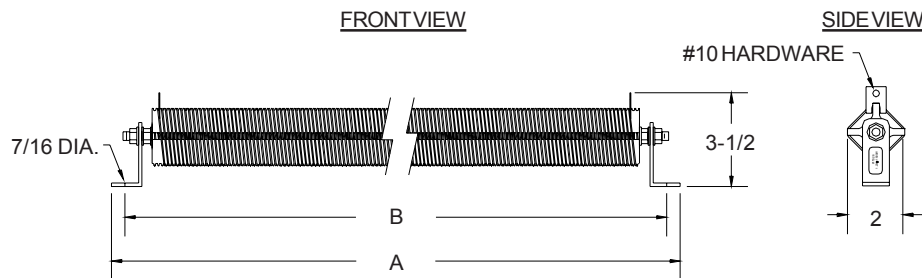

## B2 BRACKET ASSEMBLY OPTIONS & DIMENSIONS

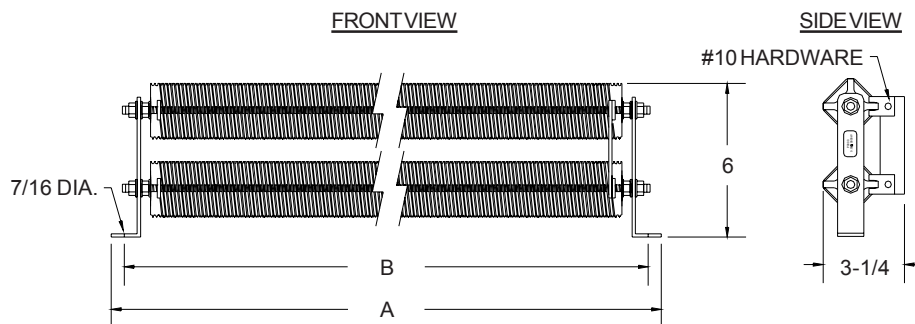

## B3 BRACKET ASSEMBLY OPTIONS & DIMENSIONS

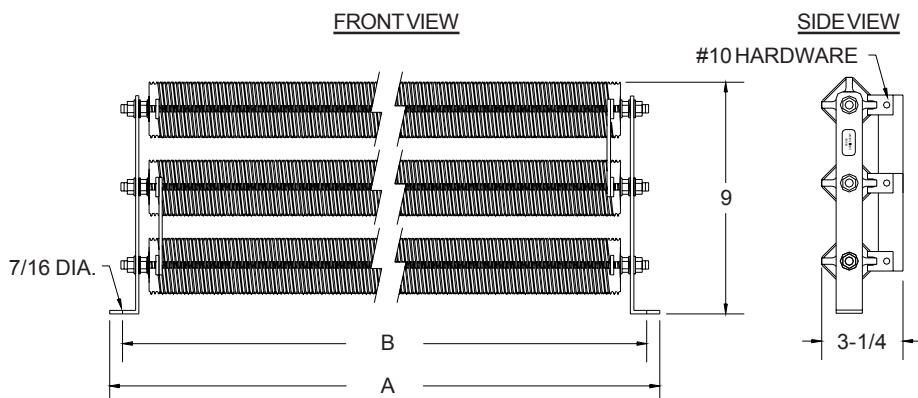



# Type WR Wirewound Resistors - 1 to 32 Amps

## APPLICATION

Powerohm's Type WR Wirewound Resistors are designed for low current applications ranging from 1.0 to 32.0 amps continuous, and resistance values ranging between 250.0 and 0.25 ohms, respectively. Units have a rated temperature rise of 375°C above ambient temperature, which is in accordance with NEMA standards.

These units can be used for any type of AC or DC power application, including motor control, dynamic braking, neutral grounding and load testing. The corrosion resistant Type WR resistor will withstand considerable shock and vibration, qualifying it for use in most harsh environments.

## BASIC CONSTRUCTION

The Type WR resistor unit consists of a high quality alloy wire coil supported by a spirally-grooved insulating core. The spring-shaped element is attached to either end of the core by rigid stainless steel terminals. This design offers sound mechanical strength, and the ability to package a large amount of active element in a small area.

The open-type construction is the key to the efficient cooling ability of the unit. Unlike enamel or ceramic coated resistors which tend to "trap" the heat, the Type WR resistor allows the element to come in direct contact with the cool ambient air. This unique design allows rapid, natural convection cooling of the resistive element.

Our resistors feature stainless steel element and terminals. The terminals are designed to allow the use of flat bus bars for coil-to-coil connections when the resistors are mounted in our standard selection of enclosures. Our terminals and bus bars are fabricated from rolled stainless steel strip which insures smooth, rounded edges and eliminates any personnel hazard caused from sharp burrs.

The insulating core is produced from a porcelain-type ceramic material which offers good mechanical strength and excellent thermal shock resistance.

Type WR Wirewound Resistor



## ELECTRICAL CHARACTERISTICS

**VOLTAGE INSULATION:** A standard coil is insulated for 1000 volts. Standard resistor assemblies are also insulated for 1000 volts. Additional stages of insulation can be added to cater for applications exceeding 5000 volts.

**RESISTANCE TOLERANCE:** The standard tolerance for a type WR unit is + 10%. Tolerances as low as + 3% are available.

**COEFFICIENT OF RESISTIVITY:** Depending on the specific unit, the resistance will increase between 3% and 6% after reaching the maximum operating temperature of 375°C above a 40°C ambient.

**AMBIENT TEMPERATURE:** Standard ratings are based on maximum ambient temperatures of 40°C. Derate current rating 95% for 50°C ambient, 90% for 75°C ambient and 85% for 100°C ambient.

**EFFECTS OF ALTITUDE:** The published electrical ratings are applicable for altitudes of 6000 feet or less. Contact factory for deration factors above 6000 feet.

## CUSTOM DESIGNS

Powerohm offers a complete selection of standard size coils with various resistance and current ratings. We specialize in custom sizes, and can manufacture coils with any resistance rating ranging between 0.25 and 250.0 ohms at no additional charge.

# Type WR Electrical Ratings of Standard Size Coils

**RATINGS:** The electrical ratings below are the maximum for coils mounted in free air. The maximum power rating will be reduced if multiple coils are installed close together or in an enclosure that restricts ventilation. It is recommended that the factory assist you with such applications, but for approximation purposes, resistor coils mounted in a well ventilated enclosure can be rated at 90% and in an unventilated enclosure at about 80% of their continuous amp rating.

**CUSTOM SIZES:** Please note that this table contains only the most common size resistor coils. Any resistance value between 0.25 and 250.0 ohms is available.

**FIXED TAPS:** For design versatility, individual units are available with multiple fixed taps.

## ELECTRICAL RATINGS FOR CONTINUOUS AND INTERMITTANT DUTY CYCLES

PART NUMBER	RESISTANCE OHMS	WATTS	AMP RATINGS BASED ON NEMA CLASSIFICATION NUMBERS				
			CLASS 90 CONTINUOUS	CLASS 170 ON 15 SEC. OFF 15 SEC.	CLASS 160 ON 15 SEC. OFF 30 SEC.	CLASS 150 ON 15 SEC. OFF 45 SEC.	CLASS 130 ON 10 SEC. OFF 70 SEC.
WR25	0.25	256	32.0	39.0	45.0	51.0	76.0
WR30	0.30	288	31.0	37.0	43.0	49.0	74.0
WR35	0.35	294	29.0	35.0	40.0	46.0	69.0
WR50	0.50	365	27.0	33.0	38.0	43.0	65.0
WR70	0.70	339	22.0	27.0	31.0	35.0	53.0
WR100	1.00	324	18.0	22.0	25.0	29.0	44.0
WR150	1.50	338	15.0	18.0	21.0	24.0	34.0
WR200	2.00	338	13.0	15.9	18.9	20.9	29.5
WR250	2.50	360	12.0	14.2	16.2	19.1	27.5
WR350	3.50	386	10.5	12.1	13.9	16.2	22.0
WR400	4.00	400	10.0	11.5	13.2	15.4	21.0
WR450	4.50	381	9.2	10.7	12.3	13.5	20.0
WR500	5.00	361	8.5	10.4	12.4	13.0	19.3
WR550	5.50	352	8.0	10.2	11.6	12.7	17.5
WR600	6.00	347	7.6	9.8	10.8	11.9	16.7
WR700	7.00	373	7.3	8.9	9.8	10.5	15.0
WR850	8.50	417	7.0	8.2	9.2	9.7	14.2
WR1000	10.00	384	6.2	7.2	7.7	8.1	11.9
WR1200	12.00	404	5.8	7.1	7.4	7.7	11.4
WR1500	15.00	421	5.3	5.9	6.2	6.9	9.8
WR2000	20.00	423	4.6	5.4	5.8	5.7	8.1
WR2700	27.00	350	3.6	4.4	4.4	5.0	6.5
WR3600	36.00	324	3.0	3.7	4.1	4.4	5.9
WR4500	45.00	281	2.5	3.2	3.3	3.6	4.6
WR6200	62.00	248	2.0	2.5	2.7	2.9	3.7
WR8000	80.00	259	1.8	2.2	2.4	2.5	3.3
WR10000	100.00	256	1.6	2.0	2.1	2.2	2.9
WR12500	125.00	245	1.4	1.7	1.8	1.9	2.5
WR15000	150.00	254	1.3	1.6	1.7	1.8	2.3
WR17500	175.00	252	1.2	1.5	1.6	1.7	2.1
WR20000	200.00	242	1.1	1.3	1.4	1.5	1.9
WR25000	250.00	250	1.0	1.2	1.3	1.4	1.8

# Type WR Coil Dimensions & Tap Options

## DIMENSIONS AND WEIGHT OF STANDARD SIZE COILS

**AVERAGE WEIGHT:** 1.1 lbs per single coil

**DIMENSIONS:**

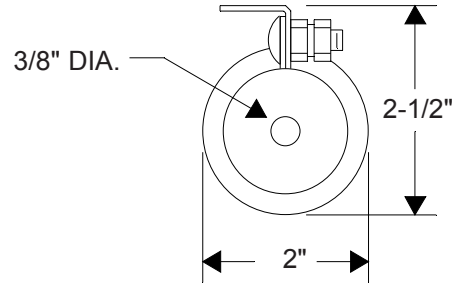
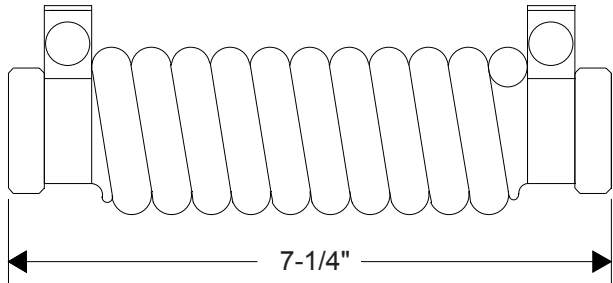

Note: Terminals are supplied with 10-24 stainless steel hardware.

## ADDING FIXED TERMINALS TO TYPE WR WIREWOUND RESISTORS

Type WR Wirewound Resistors are furnished with two rigid end terminals which are clamped at either end on the ceramic core. Additional fixed taps consist of a steel band clamped directly around the coiled element. Numerous tap configurations are available, however, fixed terminals are limited to a spacing no closer than every two turns and a maximum of four fixed taps per coil.

SPECIFY PART NUMBERS AS FOLLOWS:

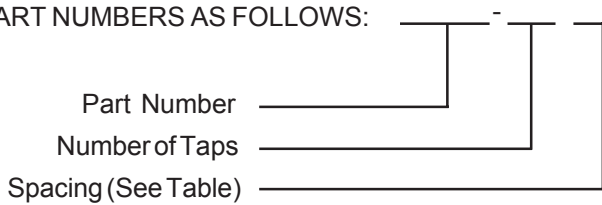

For example, the part number for a 373 watt, 7.0 ohm coil with 2 taps at 1/5 spacing is WR700-2E.

## ADDITIONAL TAPS & SPACING CHART

FRACTIONAL SPACING	SUFFIX LETTER
1/2	B
1/3	C
1/4	D
1/5	E

Examples of WR wirewound Resistors with additional taps:

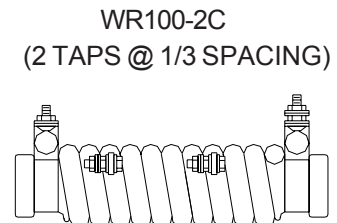
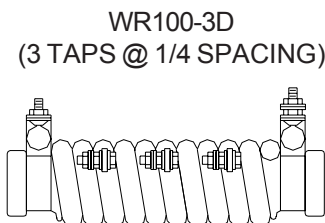
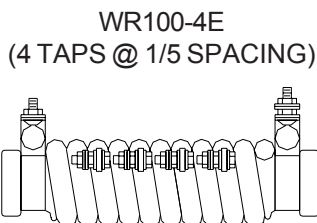
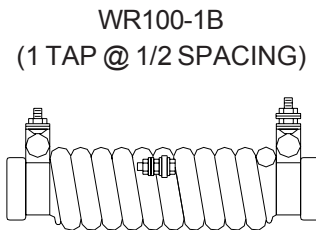

# Type WR Mounting Bracket Options and Dimensions

Type WR Wirewound Resistors are available fully assembled on open-style brackets. This open-style construction consists of resistors installed on mill galvanized brackets complete with stainless steel bus bars.

SPECIFY PART NUMBERS AS FOLLOWS:

Number of Coils in Assembly

Part Number

Bracket Identification

For example, the part number for a 373 watt, 7.0 ohm coil mounted on brackets is 1WR700-B1. Standard assemblies of 2 or more coils include series jumpers. Add "-N" to eliminate jumpers and "-P" for parallel jumpers.

## B1 BRACKET ASSEMBLY OPTIONS AND DIMENSIONS

1 Coil - B1 Bracket Assembly  
Example Part Number: 1WR700-B1

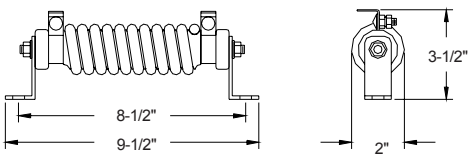

2 Coil - B1 Bracket Assembly  
Example Part Number: 2WR700-B1

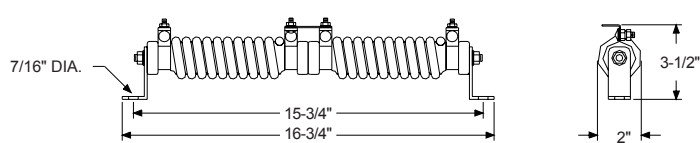

## B2 BRACKET ASSEMBLY OPTIONS AND DIMENSIONS

2 Coil - B2 Bracket Assembly  
Example Part Number: 2WR700-B2

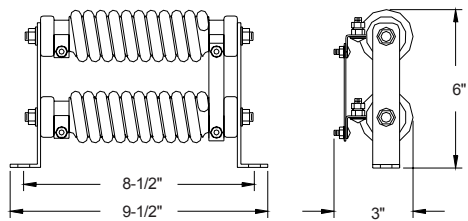

4 Coil - B2 Bracket Assembly  
Example Part Number: 4WR700-B2

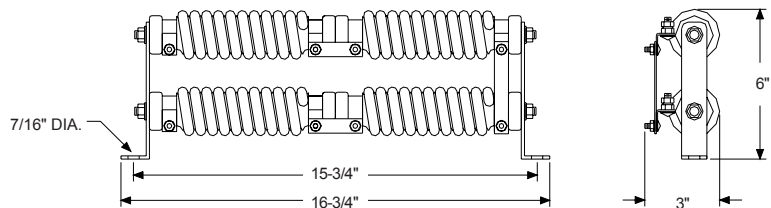

## B3 BRACKET ASSEMBLY OPTIONS AND DIMENSIONS

3 Coil - B3 Bracket Assembly  
Example Part Number: 3WR700-B3

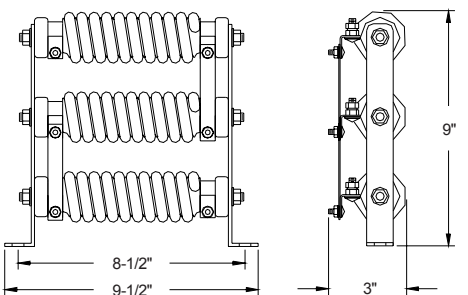

6 Coil - B3 Bracket Assembly  
Example Part Number: 6WR700-B3

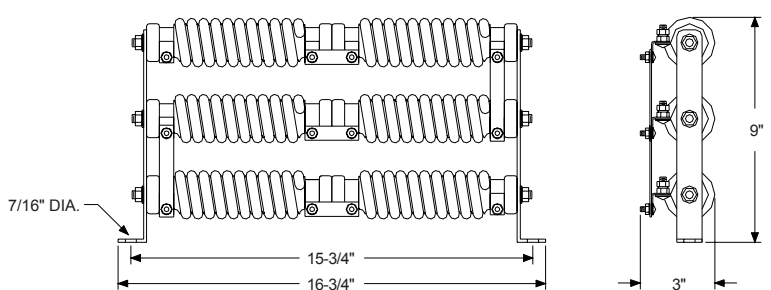

# Type ER and ERB Edgewound Resistors - 16 to 100 Amps

## APPLICATION

Powerohm's Type ER and ERB Edgewound Resistors can be used for any AC or DC power application. Units are most commonly used for VFD braking, motor control, load banks and neutral grounding applications.

The Type ER and ERB resistors are suitable for continuous duty applications where low resistance and high current are required. The high element mass allows these units to withstand high current, intermittent duty applications. This characteristic, combined with the high-temperature ceramic insulation, makes the edgewound ideal for neutral grounding applications, which reach temperatures as high as 800°C.

## BASIC CONSTRUCTION

Powerohm's Type ER and ERB resistors are lightweight, heavy-duty units consisting of a non-corrodible, high quality stainless steel alloy. The ribbon-like element is wound on edge in the form of a helix, and then spun onto a ceramic core. Type ER resistors are supported by a threaded rod passing through the center of the ceramic core. Type ERB resistors are supported by a mounting bar which is slotted at either end. Fixed terminations are made by welding stainless steel tabs to either end of the element, or at various points for multiple connections. This unit includes fixed terminals, through-rods, through-bars, hardware and stainless steel element.

Our ceramic insulating cores are manufactured in-house to maintain total control over production and quality standards. Powerohm is the only domestic resistor manufacturer with this added advantage.

## OPTIONS

**COIL SIZES:** Type ER and ERB resistors are available in (6) standard lengths, all having the same, approximate diameter of 2 inches. Wattage values vary from 400 to 2300 watts per coil. These units are available in (15) different current ratings ranging from 16 to 100 amps continuous, and resistance values between 6.2 and .06 ohms, respectively.

**ADJUSTABLE TERMINALS:** Adjustable terminals, which can be clamped to the element, are available for certain size units; add "-A" to the part number.

**ENCLOSURES:** Powerohm Type ER resistors can be packaged in our standard line of enclosures. See the Enclosure Catalog Section for details.



## ELECTRICAL CHARACTERISTICS

**VOLTAGE INSULATION:** A standard Type ER and ERB resistor is insulated for up to 1000 volts. Standard enclosures are insulated for up to 1000 volts and by adding further stages of insulation, an assembly of units can be used for applications exceeding 15 kV.

**RESISTANCE TOLERANCE:** + 10% for all units; as low as + 3% if required.

**COEFFICIENT OF RESISTIVITY:** Resistance values will increase as the element temperature rises. Expect an approximate increase of 5% in resistance after the unit reaches an operating temperature of 375°C above ambient. Contact the factory for more specific information if needed.

**AMBIENT TEMPERATURE:** Standard ratings are based on maximum ambient temperatures of 40°C. Derate current rating 95% for 50°C ambient, 90% for 75°C ambient, and 85% for 100°C ambient.

**EFFECTS OF ALTITUDE:** The published electrical ratings are applicable for altitudes of 6000 feet or less. Contact the factory for deration factors above 6000 feet.

## CUSTOM DESIGNS

Powerohm offers a complete selection of standard size coils on the following page. These coils cover a wide range of resistance and current values. Numerous variations are available for special applications or replacement of other manufacturers. Powerohm can match the electrical ratings of any edgewound product available. Please contact the factory for assistance.

# Type ER Electrical Ratings & Coils Dimensions

**SPECIFY PART NUMBERS AS FOLLOWS:** ER or ERB - Length - Amp Rating

For example, the part number of a Type ER, 50 amp, 0.51 ohm coil is ER5-50.

**RATINGS:** The continuous current ratings are based on a 375°C temperature rise. The resistance values are measured at 25°C and have a + 10% tolerance.

## ELECTRICAL RATINGS OF STANDARD SIZE COILS

CONTINUOUS AMP RATING	RESISTANCE IN OHMS					
	LENGTH 2	LENGTH 3	LENGTH 4	LENGTH 5	LENGTH 6	LENGTH 7
15	1.90	3.00	4.10	5.10	6.20	7.20
16	1.70	2.60	3.50	4.40	5.30	6.20
18	1.30	2.0	2.7	3.5	4.2	4.90
20	1.20	1.80	2.4	3.1	3.7	4.3
23	.89	1.37	1.85	2.3	2.8	3.3
26	.69	1.06	1.44	1.81	2.2	2.6
29	.49	.75	1.02	1.29	1.55	1.82
32	.43	.66	.90	1.13	1.37	1.60
36	.35	.54	.73	.92	1.11	1.30
40	.27	.41	.56	.70	.85	.99
45	.25	.38	.52	.65	.78	.92
50	.19	.30	.40	.51	.62	.72
60	.15	.23	.32	.40	.48	.57
70	.12	.19	.26	.33	.39	.46
85	.07	.11	.15	.19	.23	.27
100	.06	.10	.13	.16	.20	.23

**TYPE ER DIMENSIONS:** The coil dimensions are for standard size units. Coil and threaded rod length can be varied per customer request. All units have the same approximate diameter of 2 inches. Units are furnished with 5/16"-18 through rods and terminal hardware.

## STANDARD COIL DIMENSIONS

LENGTH	A	B	C
2	9-3/8	7	6-1/8
3	12-3/8	10	9-1/8
4	15-3/8	13	12-1/8
5	18-3/8	16	15-1/8
6	21-3/8	19	18-1/8
7	24-3/8	22	21-1/8

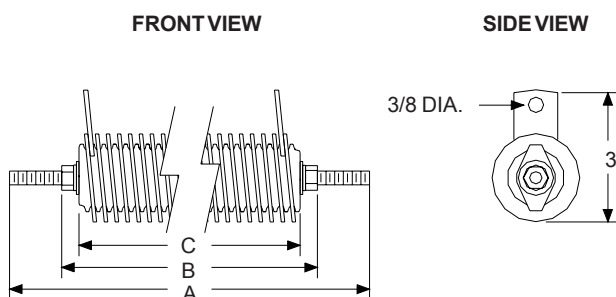



# Type ERB Coil Dimensions & Tap Options

## TYPE ERB (BAR-MOUNT) EDGEWOUND DIMENSIONS

**TYPE ERB EDGEWOUND:** Type ERB bar-mounted edgewounds are available with the same electrical ratings as the Type ER edgewounds. All units have the same approximate diameter of 2 inches. Units are furnished with a through-bar and terminal hardware.

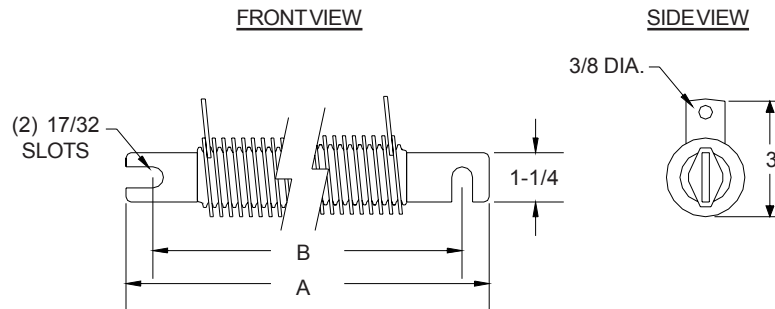

## STANDARD COIL DIMENSIONS

LENGTH	A	B
2	9-1/4	7-7/8
3	12-1/4	10-7/8
4	15-1/4	13-7/8
5	18-1/4	16-7/8
6	21-1/4	19-7/8
7	24-1/4	22-7/8

## ADDITIONAL TAPS

Type ER resistors are furnished with two stainless steel terminals at either end of the ceramic core. Additional fixed taps consist of a stainless steel terminal welded in place at various intervals. Numerous tap configurations are available, but limited to a spacing no closer than 1-1/4 inches.

**SPECIFY PART NUMBERS AS FOLLOWS:**

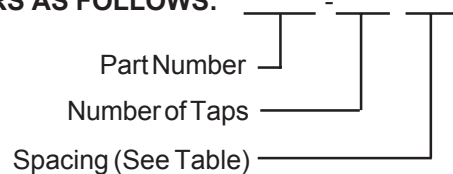

For example, the part number of a Type ER, 50 amp, 0.51 ohm coil with 2 taps at 1/3 spacing is ER5-50-2C. See below for additional part number examples.

## ADDITIONAL TAPS & SPACING CHART

FRACTIONAL SPACING	SUFFIX LETTER
1/2	B
1/3	C
1/4	D
1/5	E
1/6	F
1/7	G
1/8	H
1/9	J
1/10	K
1/11	L
1/12	M
1/13	N
1/14	P
1/15	R
1/16	S
1/17	T

Other examples of ER Edgewound Resistors with additional taps.

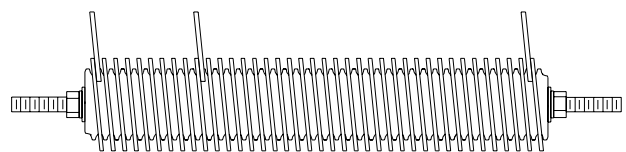

ER3-50-1D  
(1 TAP @ 1/4 SPACING)

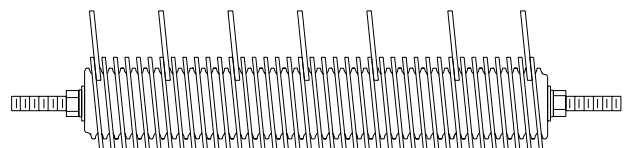

ER3-50-5F  
(5 TAP @ 1/6 SPACING)

# Type ER Mounting Bracket Options & Dimensions

Type ER Edgewound Resistors are available fully assembled on open-style brackets. This open-style construction consists of resistors installed on mill galvanized brackets complete with all hardware and stainless steel bus bars.

**SPECIFY PART NUMBERS AS FOLLOWS:**

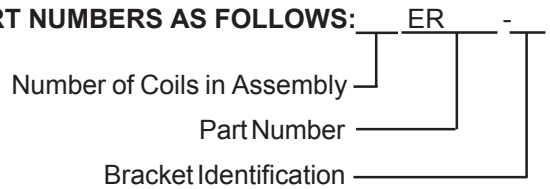

For example, the part number of a Type ER, 50 amp, 0.51 ohm coil mounted on B1 Brackets is 1ER5-50-B1. Standard assemblies of 2 or more coils include series jumpers. Add "-N" to eliminate jumpers and "-P" for parallel jumpers.

## STANDARD BRACKET DIMENSIONS

DIMENSION	SIZE 2	SIZE 3	SIZE 4	SIZE 5	SIZE 6	SIZE 7
A	9	12	15	18	21	24
B	8	11	14	17	20	23

## B1 BRACKET ASSEMBLY OPTIONS & DIMENSIONS

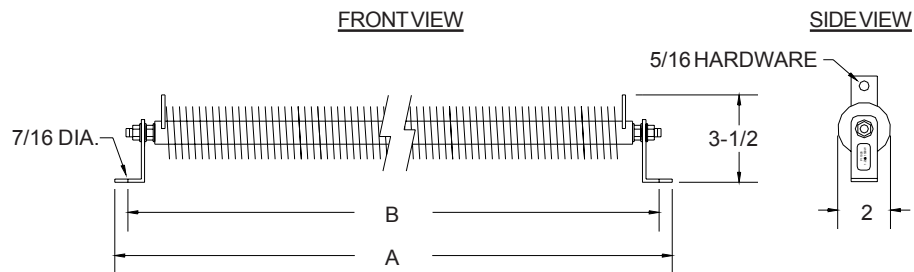

## B2 BRACKET ASSEMBLY OPTIONS & DIMENSIONS

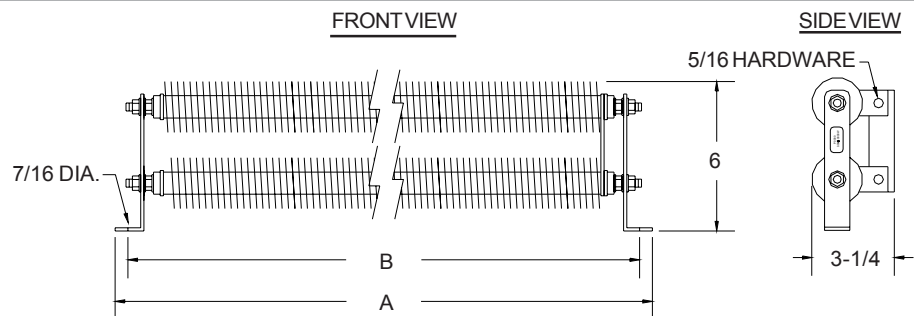

## B3 BRACKET ASSEMBLY OPTIONS & DIMENSIONS

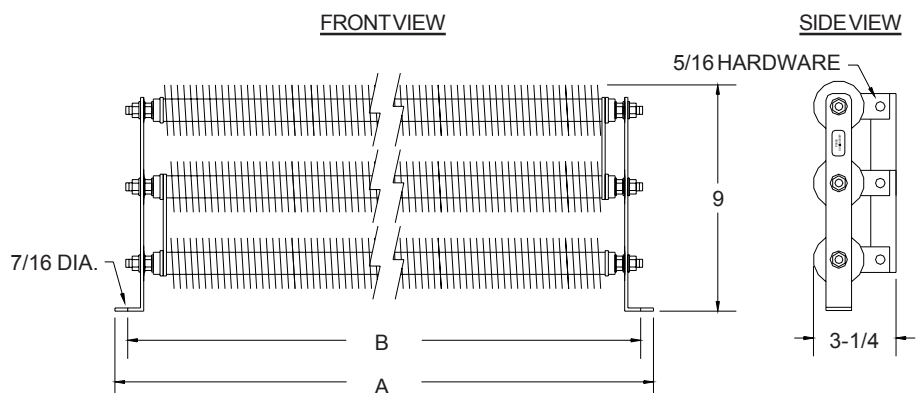

# Type GL, GM & RH Resistors - 27 to 525 Amps

## APPLICATION

Powerohm's grid and ribbon resistors can be used for any AC or DC power application. Units are most commonly used for motor acceleration and braking, but are also suitable for load banks, harmonic filtering and some neutral grounding applications.

The combination of stainless steel elements and rugged features make these units suitable for use in almost any environment. These designs are ideal for high vibration areas such as overhead cranes operated in steel mills and manufacturing plants.

## BASIC CONSTRUCTION

Powerohm's grid and ribbon resistors are the most well designed resistor banks on the market. All banks feature stainless steel elements, stainless steel terminals, double insulation from the endframes, and most importantly, offset grid elements to eliminate current carrying washers. We offer three basic designs:

**Type GL Grid Resistor:** The Type GL resistor consists of stainless steel stamped grid elements. The elements are offset and supported on mica tubes and compressed between the endframes with threaded rods. All banks with a current rating greater than 40 amps are tig welded to form a continuous, unbreakable current path. These units are most commonly used in lower and medium horsepower motor control applications.

**Type GM Grid Resistor:** The Type GM resistor features a wider, heavier duty stainless steel stamped grid element than the GL. All elements are offset and tig welded to form an unbreakable current path. These units are most commonly used in medium and higher horsepower motor control applications.

**Type RH Ribbon Resistor:** The Type RH resistor consists of a continuous stainless steel ribbon element. The ribbon element is formed by folding a wide strip of stainless alloy back and forth to produce an evenly spaced bank. Heavy duty stainless terminals are welded to the element to form a solid connection. These units are virtually indestructible and ideal for any high current application.

Type GL Grid Resistor - 27 thru 91 amps



Type GM Grid Resistor - 100 thru 165 amps



Type RH Grid Resistor - 180 thru 525 amps



## CUSTOM DESIGNS

Powerohm offers a complete selection of standard size designs. These banks cover a wide range of resistance and current values and contain numerous fixed taps. Other variations are available to meet almost any application, including custom lengths and tapered designs. Tapered resistor banks, which are normally used for motor starting, contain grids with different current ratings to reduce size and cost.

# Electrical Ratings & Bank Weights

**RATINGS:** The continuous current ratings are based on a 375°C temperature rise. The resistance values are measured at 25°C and have a + 10% tolerance.

ELECTRICAL RATINGS AND WEIGHTS OF STANDARD SIZE RESISTOR BANKS					
PART NUMBER	RESISTANCE IN OHMS	CONTINUOUS AMP RATING	WATTAGE RATING	NUMBER OF TERMINALS	APPROXIMATE WEIGHT
GL27	9.36	27	6820	13	30
GL30	7.80	30	7020	11	28
GL37	6.16	37	8430	11	29
GL41	5.10	41	8570	11	32
GL46	3.92	46	8290	10	29
GL50	2.94	50	7350	11	24
GL57	2.02	57	6560	11	27
GL63	1.82	63	7220	10	26
GL73	1.22	73	6500	10	29
GL80	1.03	80	6590	10	32
GL85	.850	85	6140	9	31
GL91	.705	91	5830	8	31
GM100	.608	100	6080	10	26
GM110	.468	110	5660	10	28
GM120	.421	120	6060	10	29
GM135	.360	135	6560	10	32
GM150	.267	150	6000	8	31
GM165	.240	165	6530	8	33
RH180	.226	180	7320	10	36
RH200	.209	200	8360	8	37
RH225	.184	225	9310	8	38
RH260	.164	260	11080	8	40
RH300	.132	300	11880	8	43
RH350	.096	350	11760	8	42
RH400	.076	400	12160	7	46
RH450	.056	450	11340	7	47
RH525	.039	525	10750	7	48

**CUSTOM DESIGNS:** The above table contains our standard selection of grid bank designs. These banks cover a wide range of resistance and current values and contain numerous fixed taps for maximum flexibility. Other variations are available for any application, including custom lengths, widths and tapered designs. Tapered resistor banks, which are normally used for motor starting, contain grids with different current ratings to reduce size and cost.

# Master Cross Reference

The following table contains all the major resistor manufacturers and the part numbers that can be replaced with Powerohm's standard resistor bank designs.

POWEROHM REPLACEMENT RESISTOR BANKS FOR OTHER MAJOR MANUFACTURERS							
POWEROHM	GENERAL ELECTRIC	CUTLER HAMMER	SQUARE D	HUBBELL	WESTINGHOUSE	POST GLOVER	CLARK - CHALLENGER
GL27 GL30 GL37	A001A210 A001A209	G11WL800 G11WL625	TW27D TW32D	SSR22 SSR24 SSR27	44A6415G01 44A6412G03	G111R-G G0111-G	
GL41 GL46 GL50	A001A208 A001A207	G11WL500 G11WL400 G11WL320	TW37D TW42D TW50D	SSR30 Z41W3900GB Z53W2500GB	44A6412G02 44A6412G01 44A6413G01	G110-G G19-G G019-G	112A38 112A44
GL57 GL63 GL73	A001A206 A001A205	G11WL200 G11WL160 G11WL125	TW62D	Z62W1990GB Z66W1620GB Z77W1210GB	44A6410G03 44A6411G01	G018-G G17-G G16R-G	112A53 112A63
GL80 GL85 GL91	A001A104	G11WL100 G11WL80	TW72D TW85D	Z80W1020GB Z95W808GB Z98W680GB	44A6410G02 44A6410G01 44A6409G03	G16-G G016-G G15-G	112A75 112A90
GM100 GM110 GM120	A001A103	G11WL62 G11WL50 G11WL40	TW100D	Z101W595GB Z117W463GB Z120W405GB	44A6408G03	G015H-G G14H-G G014H-G	112A110 112A120
GM135 GM150 GM165	A001A102	G11WL32 G11WL25	TW120D TW150D	Z124W357GB HHC150Z	44A6408G02 44A6408G01	G13H-G G58R-G	112A140 112A155
RH180 RH200 RH225		G11WL20	TW180D	Z171W206GB		G55R-G	
RH260 RH300 RH350	A001A101 A002A103	G11WL16 G11WL12		HHC200Z HHC225Z HHC295Z		HC180-G HC225-G HC300-G	
RH400 RH450 RH525	A002A102 A002A101 A004A103	G14WL06 G14WL05 G14WL03	TW280D TW360D TW430D	HHC350Z HHC395Z HHC500Z		HC350-G HC400-G HC525-G	

**ELECTRICAL RATINGS:** Powerohm resistor banks are designed to replace all of the major manufacturers. These units are electrically equivalent and are designed to have the same resistance rating. In most cases, our banks will have a higher current rating, allowing the unit to operate cooler and last longer.

**DIMENSIONS:** Powerohm banks feature universal "mill-frames" and are physically interchangeable with the competitive unit. Please refer to the previous page for specific mounting dimensions.

**TERMINAL CONFIGURATION:** In some cases, the location and number of the terminals may vary from the unit being replaced. Please specify if your application requires special terminal configurations.

# Bank Dimensions & Terminal Details

## TYPE GL AND GM GRID BANK DIMENSIONS AND TERMINAL DETAIL

**BANK DIMENSIONS:** The listed dimensions are for standard size banks. Other size variations are available for special applications or space constraints.

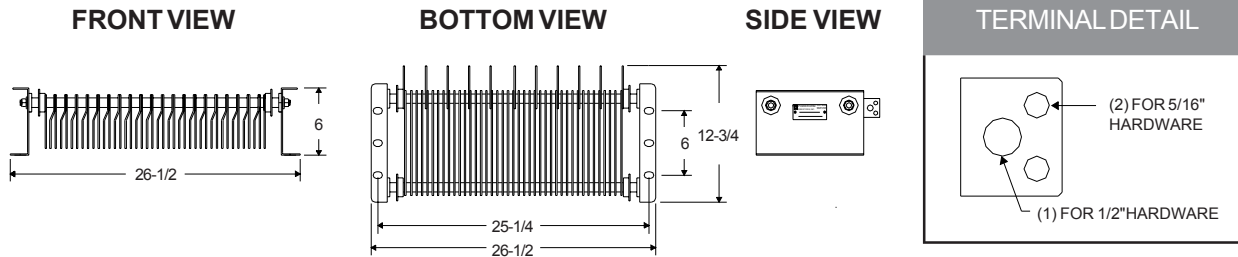

Type **GL** and **GM** terminals are designed to accept either (2) 5/16 or (1) 1/2 inch hardware. All banks have stainless steel terminals.

## TYPE RH RIBBON BANK DIMENSIONS AND TERMINAL DETAIL

**BANK DIMENSIONS:** The listed dimensions are for standard size banks. Other size variations are available for special applications or space constraints.

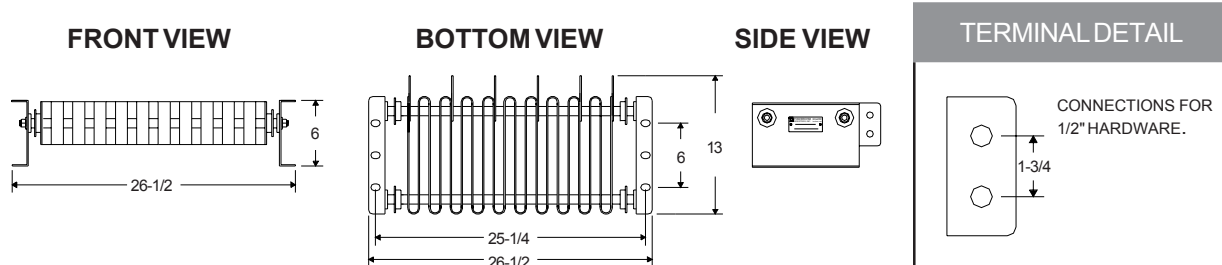

Type **RH** terminals are designed to accept 1/2 inch hardware only. All banks have stainless steel terminals.

## LS STYLE RESISTOR ASSEMBLIES

LS style resistor assemblies are an economical way to enclose one to three banks. LS style endframes are larger than standard frames to provide required electrical clearances, and have four flanges allowing the banks to be bolted together. Assemblies come complete with a perforated or louvered cover and all necessary bank-to-bank connections.

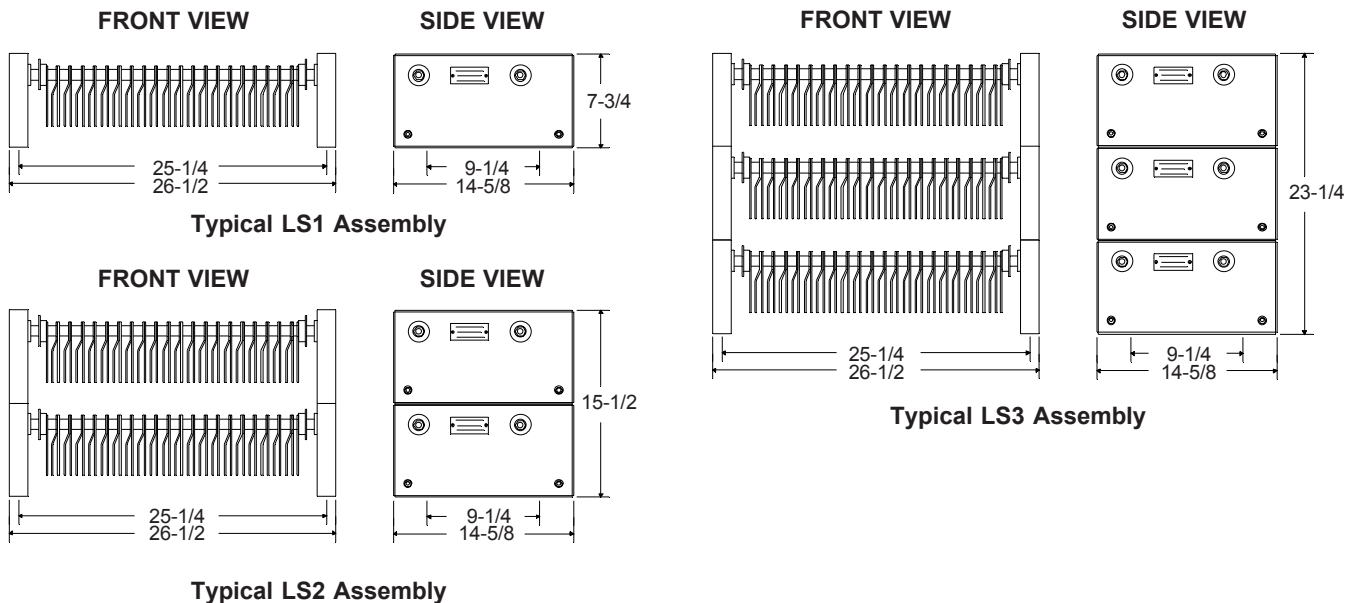



# Type GLE Enclosures

The Type GLE enclosure is our most common and economical means for housing wirewound and edgewound resistor coils with a removable cover and open bottom. These units consist of heavy gage endframes supporting the resistor coils with a removable cover and open bottom. The 3-sided screened covers are CNC punched producing a burr free edge and professional aesthetics. Resistor coils are interconnected using hardware and stainless steel bus bars, insuring a corrosion resistant current path to withstand nearly any harsh industrial environment. The standard finish is galvanized, but an optional powder coated, yellow zinc, aluminum or stainless steel finish is available upon request.

The GLE enclosures are designed for easy installation and wiring. The bottom mounting flanges are bent outward, allowing the units to be quickly installed with a ratchet or screwdriver. Endframes come complete with removable 1/2 inch conduit knockouts for easy wiring. Remember to use only 150°C rated silicone or teflon wire when attaching directly to resistor terminals. Our wide selection of Type GLE enclosures are available with a louvered cover; add "-L" to the part number.

## GLE ENCLOSURE DIMENSIONS AND COIL OPTIONS

PART NUMBER	MAX. NO. WR COILS	MAX. NO. SXR,VR or ER	DIMENSIONS IN INCHES				
			A	B	C	D	E
GLE11	1	(1) SIZE 2	12	5	4	11-1/8	—
GLE12	2	(2) SIZE 2	12	7	5	11-1/8	4-1/2
GLE13	3	(3) SIZE 2	12	10	5	11-1/8	7-1/2
GLE14	4	(4) SIZE 2	12	13	5	11-1/8	10-1/2
GLE15	5	(5) SIZE 2	12	16	5	11-1/8	13-1/2
GLE23	6	(3) SIZE 5	19	10	5	18-1/8	7-1/2
GLE24	8	(4) SIZE 5	19	13	5	18-1/8	10-1/2
GLE25	10	(5) SIZE 5	19	16	5	18-1/8	13-1/2
GLE26	12	(6) SIZE 5	19	10	10	18-1/8	7-1/2
GLE28	16	(8) SIZE 5	19	13	10	18-1/8	10-1/2
GLE33	9	(3) SIZE 7	26-1/2	10	5	25-3/8	7-1/2
GLE34	12	(4) SIZE 7	26-1/2	13	5	25-3/8	10-1/2
GLE35	15	(5) SIZE 7	26-1/2	16	5	25-3/8	13-1/2
GLE36	18	(6) SIZE 7	26-1/2	10	10	25-3/8	7-1/2
GLE38	24	(8) SIZE 7	26-1/2	13	10	25-3/8	10-1/2
GLE310	30	(10) SIZE 7	26-1/2	16	10	25-3/8	13-1/2
GLE312	36	(12) SIZE 7	26-1/2	13	15	25-3/8	10-1/2
GLE315	45	(15) SIZE 7	26-1/2	16	15	25-3/8	13-1/2

**TOP VIEW**

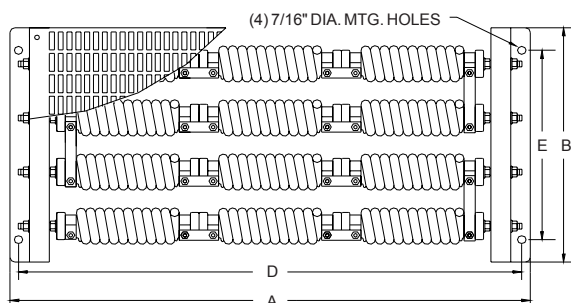

**FRONT VIEW**

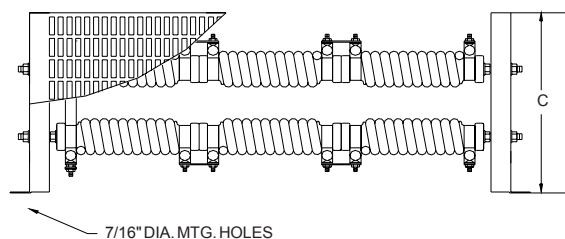

**Typical GLE Enclosure containing (24) WR Type Resistors - Part No. GLE38**

# Type GCE Enclosures

The Type GCE compartment enclosure offers several additional features and options for simplifying an installation. These heavy gage screened enclosures feature a solid bottom and a built-in compartment separated from the resistor assembly. The resistors are factory wired to a terminal block mounted in this compartment using high temperature teflon or silicone wire. During installation, standard 90°C rated wire is routed into the compartment through the removable 1/2 inch conduit knockouts and connected to the factory wired terminal block. The terminal compartment wall is pre-punched for an optional thermal switch for sensing a over-temperature condition.

Our standard unit includes a screened cover which is CNC punched to obtain maximum cooling and professional aesthetics. Mounting holes are located inside the enclosure and can be easily accessed by removing the cover. Resistor coils are interconnected using stainless steel bus bars, producing a corrosion resistant current path to withstand nearly any harsh industrial environment. The standard finish is galvanized, but an optional powder coated, yellow zinc, aluminum or stainless steel finish is available upon request. As shown in the table below, the size of the enclosure will vary depending on the number of resistor coils required for your application. Please do not hesitate to call the factory if you need assistance. Units are available with a louvered cover; add "-L" to the part number and note that the 'A' and 'B' dimensions will increase by an inch.

## GCE ENCLOSURE DIMENSIONS AND COIL OPTIONS

PART NUMBER	MAX. NO. WR COILS	MAX. NO. SXR,VR or ER	DIMENSIONS IN INCHES				
			A	B	C	D	E
GCE1	1	(1) SIZE 2	12	5	5	10-1/2	—
GCE2	2	(2) SIZE 2	12	7	5	10-1/2	4-1/2
GCE3	3	(3) SIZE 2	12	10	5	10-1/2	7-1/2
GCE4	4	(4) SIZE 2	12	13	5	10-1/2	10-1/2
GCE5	5	(5) SIZE 2	12	16	5	10-1/2	13-1/2
GCE6	6	(3) SIZE 5	19	10	5	17-1/2	7-1/2
GCE8	8	(4) SIZE 5	19	13	5	17-1/2	10-1/2
GCE9	9	(3) SIZE 7	26-1/2	10	5	25	7-1/2
GCE10	10	(5) SIZE 5	19	16	5	17-1/2	13-1/2
GCE12	12	(4) SIZE 7	26-1/2	13	5	25	10-1/2
GCE15	15	(5) SIZE 7	26-1/2	16	5	25	13-1/2
GCE18	18	(6) SIZE 7	28	10	10	26-1/2	7-1/2
GCE24	24	(8) SIZE 7	28	13	10	26-1/2	10-1/2
GCE30	30	(10) SIZE 7	28	16	10	26-1/2	13-1/2

### TOP VIEW

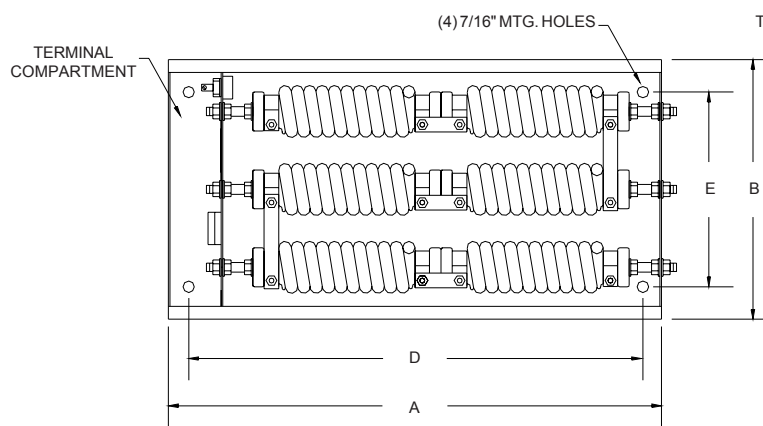

### LEFT SIDE VIEW

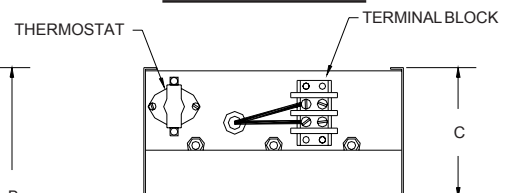

Typical GCE Enclosure containing (6) WR Type Resistors - Part No. GCE6

# Type EE Enclosures

The Type EE enclosure is designed for applications requiring a large number of Type SXR, WR, VR and/or ER resistor coils. In addition to the large capacity, these units are available with several options to simplify installation. We offer optional terminal connections up to 400 amps continuous located on a terminal plate in the bottom of the enclosure. These factory wired connections allow standard 90°C rated wire to be used if routed along the enclosure bottom. If installing without the optional terminal connections, always use 150°C rated silicone or teflon wire when attaching directly to resistors.

These rigid enclosures include a screened top and removable front and back screened covers. The enclosure sides and bottom are solid and furnished with two lifting eyes. Mounting holes are located inside the enclosure and can be easily accessed by removing the front or back cover. Resistor coils are interconnected using stainless steel bus bars, producing a corrosion resistant current path to withstand nearly any harsh industrial environment. The standard finish is galvanized, but an optional powder coated, hot dipped galvanized, aluminum or stainless steel finish is available upon request. As shown in the table below, the size of the enclosure will vary depending on the number of resistor coils required for your application. Units are available with louvered covers; add "-L" to the part number. Please do not hesitate to call the factory if you need assistance.

## EE ENCLOSURE DIMENSIONS AND COIL OPTIONS

PART NUMBER	MAX. NO. WR COILS	MAX. NO. SXR, VR OR ER	DIMENSIONS IN INCHES				
			A	B	C	D	E
EE1	18	(9) SIZE 5	30	23	12	26-1/2	18
EE2	36	(18) SIZE 5	30	23	18	26-1/2	18
EE3	54	(27) SIZE 5	30	23	24	26-1/2	18
EE4	72	(36) SIZE 5	30	23	30	26-1/2	18
EE5	90	(45) SIZE 5	30	23	36	26-1/2	18
EE6	108	(54) SIZE 5	30	23	48	26-1/2	18
EE7	126	(63) SIZE 5	30	23	60	26-1/2	18
EE8	144	(72) SIZE 5	30	23	72	26-1/2	18
EE9	162	(81) SIZE 5	30	23	84	26-1/2	18

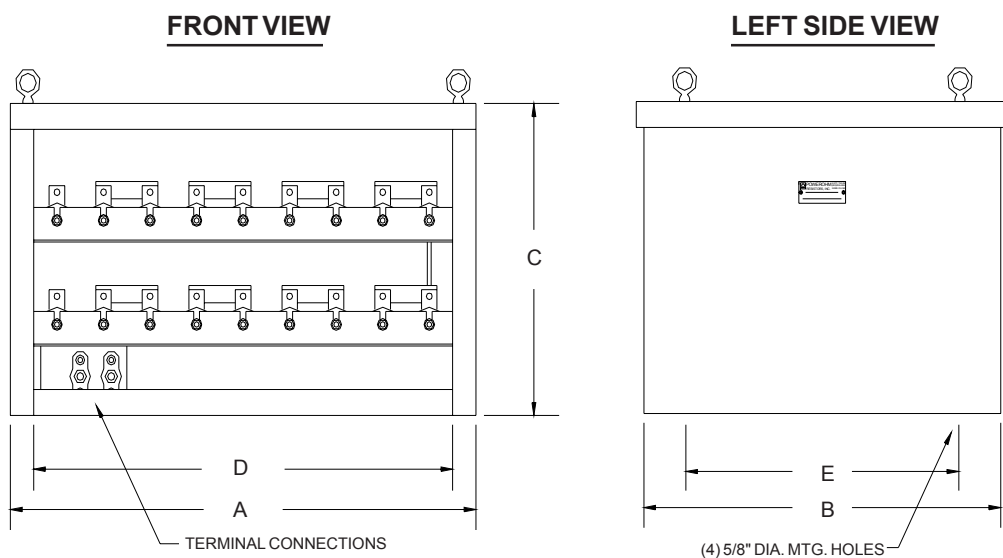

**Type EE2 Enclosure shown with optional terminal connections.**

# Type EG Enclosures

The Type EG enclosure is specifically designed to house our Type GL, GM and RH resistor banks. The enclosure is designed with shelves so individual banks can be easily installed or replaced. Assemblies come complete with all necessary bank-to-bank connections consisting of either high temperature insulated wire or copper bus bars. These rigid, free standing enclosures include a screened top and removable front and back screened covers. The enclosure sides and bottom are solid and the unit is furnished with two lifting eyes. The mounting holes are located inside the enclosure and can be easily accessed by removing the front or back cover.

The Type EG enclosure also has the capability of housing Type SXR, WR, VR and ER resistor coils. Resistor coils are installed on endframes and interconnected with stainless steel bus bars producing a corrosion resistant current path to assure long life in nearly any industrial environment.

The standard finish is galvanized, but an optional powder coated, hot dipped galvanized, aluminum, or stainless steel finish is available upon request. As shown in the table below, the size of the enclosure will vary depending on the number of resistors required for your application. Units are available with a louvered cover; add "-L" to the part number. Always use 150°C rated silicone or teflon wire when attaching directly to resistor terminals. Please call the factory if you need assistance.

## EG ENCLOSURE DIMENSIONS AND RESISTOR OPTIONS

PART NUMBER	NO. OF GRID BANKS	MAX. NO. SXR, VR, ER	MAX. NO. WR COILS	DIMENSIONS IN INCHES				
				A	B	C	D	E
EG1	1	(4) SIZE 7	12	30	17	14	26-1/2	12
EG2	2	(8) SIZE 7	24	30	17	23	26-1/2	12
EG3	3	(12) SIZE 7	36	30	17	32	26-1/2	12
EG4	4	(16) SIZE 7	48	30	17	41	26-1/2	12
EG5	5	(20) SIZE 7	60	30	17	50	26-1/2	12
EG6	6	(24) SIZE 7	72	30	17	59	26-1/2	12
EG7	7	(28) SIZE 7	84	30	17	68	26-1/2	12
EG8	8	(32) SIZE 7	96	30	17	77	26-1/2	12
EG9	9	(36) SIZE 7	108	30	17	86	26-1/2	12

**FRONT VIEW**

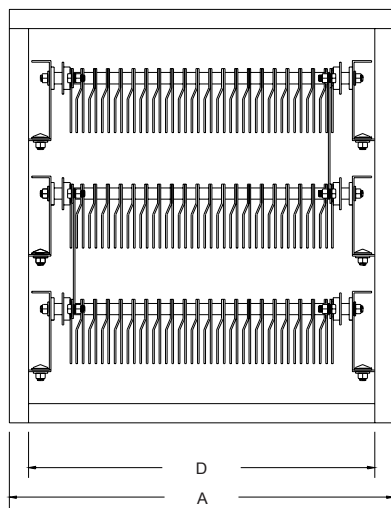

**LEFT SIDE VIEW**

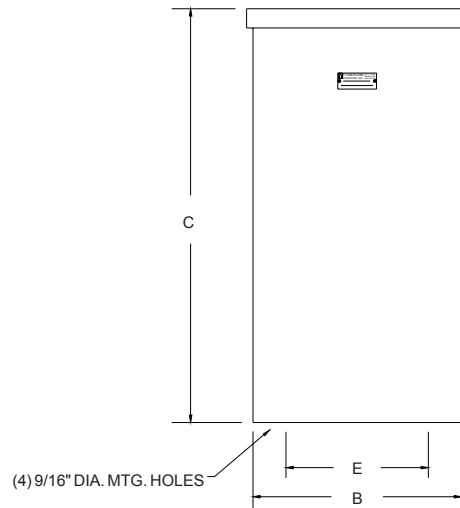

**Type EG3 Enclosure shown containing (3) Grid Banks.**

**24 HOUR EMERGENCY SERVICE (800) 838-4694**

# Braking Resistors for Variable Frequency Drives

## APPLICATION

AC variable frequency drives are commonly used with a general purpose AC induction motor to form a reliable variable speed drive system. For applications that require faster deceleration rates, or where motor speeds are exceeding the synchronous speed set by the output frequency of the drive (an overhauling load condition), a braking resistor is required. Braking resistors increase the braking torque capability of a variable frequency drive, producing faster and more controlled braking. The resistor dissipates regenerated power to keep the bus voltage from exceeding the rated limit of the drive.

## SELECTING A STANDARD DESIGN

Powerohm offers a standard selection of braking resistors for 230V, 460V and 575V drives. These braking resistors are designed to produce either 100% or 150% braking torque and are available in five standard duty cycles. The following information is required to select a standard design:

### Data Requirements:

- Drive Horsepower
- Drive Input Voltage
- Braking Torque
- Duty Cycle
- Minimum ohm rating specified for your drive or braking module, or maximum allowable braking current.

**Braking Torque:** The resistance determines the braking torque and thus the deceleration rate of the motor. It is important that the resistance value must be within the allowable limits of the drive or braking module (too low of a value may cause harm to the drive or chopper). Also, when the braking module activates, the resistance value will produce a specific braking current. The peak braking currents of each standard design are listed with each resistor design and must not exceed the rated limits of your drive or braking module.

**Duty Cycle:** The duty cycle determines the power rating of the braking resistor. Duty cycle is calculated by dividing the braking stop time by the total cycle time as follows:

$$\text{Duty Cycle} = t_b / t_c \times 100\%$$

Also, it is important to determine whether your application is an overhauling load cycle or a deceleration braking cycle (refer to the graphs for proper identification).

## Typical Dynamic Braking Resistor Assembly



**Overhauling Load Cycle:** Requires the braking resistor to keep the motor from increasing speed beyond the synchronous speed set by the drive. During an overhauling load cycle, the required braking torque remains constant, therefore, approximately twice the power of an deceleration braking cycle is required of the braking resistor.

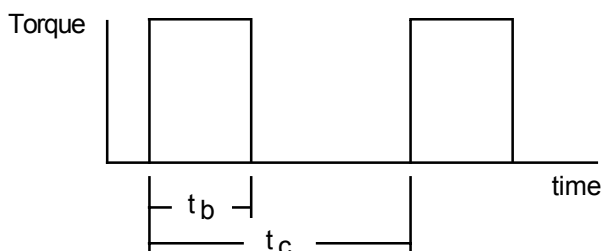

**Deceleration Braking Cycle:** Requires the braking resistor to stop or reduce the speed of the motor. During deceleration braking, the required braking torque reduces with speed, therefore, approximately one-half the power of an overhauling load cycle is required of the braking resistor.

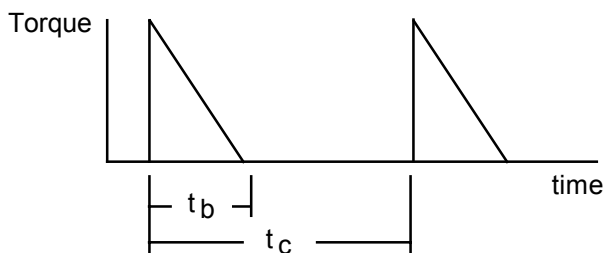

## CUSTOM RATINGS

Powerohm offers a complete selection of standard size braking resistors to meet a wide variety of applications. We can, however, customize a braking resistor to meet your specific application requirements. Please call us with your specification.

# Braking Resistors for 230 Volt Drives - 100% Braking Torque

## SPECIFY PART NUMBERS AS FOLLOWS: R2 -

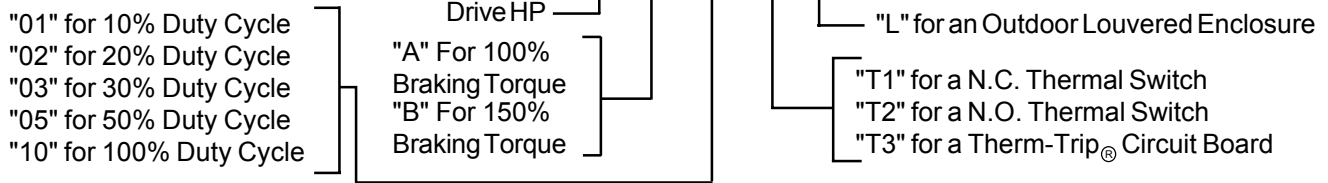

For example, the part number of a braking resistor rated for a 1/2 HP, 230V drive requiring 100% braking torque with a 100% duty cycle and an optional thermal switch with normally open contacts is R2-.5A10T2.

**CONSTRUCTION:** Standard units include resistors installed in a screened enclosure with a galvanized finish. All enclosures are assembled with stainless steel hardware. Units are furnished with resistors wired to a terminal block with high temperature silicone or teflon wire. Refer to the Enclosure Section of the catalog for enclosure details and finish options.

### BRAKING RESISTORS FOR 230V DRIVES REQUIRING 100% BRAKING TORQUE

PART NO. PREFIX	H.P.	OHMS	BRAKING AMPS	ENCLOSURE REQUIRED FOR SPECIFIED DUTY CYCLE				
				10% DUTY	20% DUTY	30% DUTY	50% DUTY	100% DUTY
R2-.5A R2-.75A	.50 .75	375.0 250.0	1.1 1.6	GCE1 GCE1	GCE1 GCE1	GCE1 GCE1	GCE1 GCE2	GCE2 GCE2
R2-1A R2-1.5A	1 1.5	190.0 125.0	2.1 3.2	GCE1 GCE1	GCE1 GCE1	GCE2 GCE2	GCE2 GCE3	GCE3 GCE4
R2-2A R2-3A	2 3	95.0 63.0	4.2 6.3	GCE1 GCE1	GCE2 GCE2	GCE2 GCE3	GCE3 GCE4	GCE4 GCE6
R2-5A R2-7.5A	5 7.5	38.0 26.0	11.0 15.0	GCE1 GCE2	GCE3 GCE4	GCE4 GCE6	GCE8 GCE12	GCE10 GCE12
R2-10A R2-15A	10 15	19.0 12.6	21.0 32.0	GCE2 GCE3	GCE5 GCE6	GCE9 GCE9	GCE12 GCE15	GCE15 GCE24
R2-20A R2-25A	20 25	9.6 7.5	42.0 53.0	GCE4 GCE5	GCE6 GCE8	GCE12 GCE15	GCE24 GCE24	GCE30 GCE30
R2-30A R2-40A	30 40	6.3 4.9	63.0 82.0	GCE6 GCE6	GCE12 GCE15	GCE18 GCE24	GCE30 GCE30	EE2 EE3
R2-50A R2-60A	50 60	3.9 3.3	100.0 120.0	GCE8 GCE8	GCE18 GCE18	GCE24 EE2	EE3 EE3	EE3 EE4
R2-75A R2-100A	75 100	2.7 1.9	150.0 210.0	GCE8 GCE10	GCE24 GCE24	EE2 EE3	EE4 EE5	EE6 EE6
R2-125A R2-150A	125 150	1.6 1.3	250.0 310.0	GCE18 GCE18	EE3 EE4	EE4 EE4	EE5 EE7	EE8 EE8
R2-200A R2-250A	200 250	1.0 0.8	400.0 500.0	GCE24 GCE30	EE4 EE4	EE6 EE8	EE9 EE9	(2)EE6 (2)EE8



# Braking Resistors for 230 Volt Drives - 150% Braking Torque

**RATINGS:** Powerohm braking resistors are available in either 100% or 150% braking torque and (5) duty cycles based on a cycle time of one minute. Powerohm braking resistors are designed for a 375°C temperature rise when operating at the maximum rated duty cycle. The resistance values are measured at 25°C and have a + 10% tolerance.

**CAUTION:** It is very important to insure that the resistance listed in the chart below is greater than the minimum specified for your drive or braking module. Installing a braking resistor with too low of a resistance value will cause permanent damage to your drive or braking module. Please call the factory if you need assistance.

MAXIMUM BRAKING TIMES OF DUTY CYCLES		
Duty Cycle	Maximum Braking Time	
	Overhauling Load	Deceleration Braking
10%	6 sec.	12 sec.
20%	12 sec.	24 sec.
30%	18 sec.	36 sec.
50%	30 sec.	Continuous
100%	Continuous	Continuous

BRAKING RESISTORS FOR 230V DRIVES REQUIRING 150% BRAKING TORQUE								
PART NO. PREFIX	H.P.	OHMS	BRAKING AMPS	ENCLOSURE REQUIRED FOR SPECIFIED DUTY CYCLE				
				10% DUTY	20% DUTY	30% DUTY	50% DUTY	100% DUTY
R2-.5B R2-.75B	.50 .75	250.0 170.0	1.6 2.4	GCE1 GCE1	GCE1 GCE1	GCE1 GCE2	GCE2 GCE2	GCE2 GCE3
R2-1B R2-1.5B	1 1.5	125.0 85.0	3.2 4.7	GCE1 GCE1	GCE1 GCE2	GCE2 GCE3	GCE3 GCE4	GCE4 GCE5
R2-2B R2-3B	2 3	63.0 42.0	6.3 9.5	GCE1 GCE1	GCE2 GCE3	GCE3 GCE4	GCE4 GCE8	GCE6 GCE9
R2-5B R2-7.5B	5 7.5	25.0 16.8	16.0 24.0	GCE2 GCE2	GCE4 GCE6	GCE6 GCE9	GCE12 GCE12	GCE12 GCE15
R2-10B R2-15B	10 15	12.6 8.4	32.0 48.0	GCE3 GCE5	GCE6 GCE8	GCE9 GCE15	GCE15 GCE24	GCE24 GCE30
R2-20B R2-25B	20 25	6.3 5.0	63.0 80.0	GCE6 GCE6	GCE12 GCE15	GCE18 GCE24	GCE30 EE2	EE2 EE3
R2-30B R2-40B	30 40	4.2 3.2	95.0 125.0	GCE8 GCE8	GCE15 GCE18	GCE24 EE2	EE3 EE3	EE3 EE4
R2-50B R2-60B	50 60	2.5 2.1	160.0 190.0	GCE8 GCE10	GCE30 GCE30	EE2 EE3	EE3 EE5	EE7 EE7
R2-75B R2-100B	75 100	1.7 1.3	235.0 310.0	GCE12 GCE18	EE3 EE3	EE4 EE4	EE5 EE7	EE9 EE9
R2-125B R2-150B	125 150	1.0 0.85	400.0 470.0	GCE24 GCE24	EE3 EE4	EE5 EE6	EE7 (2)EE5	(2)EE6 (2)EE8
R2-200B R2-250B	200 250	0.65 0.50	610.0 800.0	EE2 EE3	EE4 EE5	EE8 (2)EE5	(2)EE7 (2)EE7	(2)EE8 (3)EE8

# Braking Resistors for 460 Volt Drives - 100% Braking Torque

**SPECIFY PART NUMBERS AS FOLLOWS:** R4 -

"01" for 10% Duty Cycle  
 "02" for 20% Duty Cycle  
 "03" for 30% Duty Cycle  
 "05" for 50% Duty Cycle  
 "10" for 100% Duty Cycle

DriveHP  
 "A" For 100%  
 Braking Torque  
 "B" For 150%  
 Braking Torque

"L" for an Outdoor Louvered Enclosure  
 "T1" for a N.C. Thermal Switch  
 "T2" for a N.O. Thermal Switch  
 "T3" for a Therm-Trip<sup>®</sup> Circuit Board

For example, the part number of a braking resistor rated for a 100 HP, 460V drive requiring 150% braking torque with a 50% duty cycle and an optional thermal switch with normally closed contacts is R4-100B05-T1.

**CONSTRUCTION:** Standard units include resistors installed in a screened enclosure with a galvanized finish. All enclosures are assembled with stainless steel hardware. Units are furnished with resistors wired to a terminal block with high temperature silicone or teflon wire. Refer to the Enclosure Section of the catalog for enclosure details and finish options.

## BRAKING RESISTORS FOR 460V DRIVES REQUIRING 100% BRAKING TORQUE

PART NO. PREFIX	H.P.	OHMS	BRAKING AMPS	ENCLOSURE REQUIRED FOR SPECIFIED DUTY CYCLE				
				10% DUTY	20% DUTY	30% DUTY	50% DUTY	100% DUTY
R4-.5A R4-.75A	.50 .75	1500.0 1000.0	0.5 0.8	GCE1 GCE1	GCE1 GCE1	GCE1 GCE1	GCE1 GCE1	GCE1 GCE2
R4-1A R4-1.5A	1 1.5	750.0 500.0	1.1 1.6	GCE1 GCE1	GCE1 GCE1	GCE1 GCE2	GCE2 GCE3	GCE3 GCE4
R4-2A R4-3A	2 3	375.0 250.0	2.1 3.2	GCE1 GCE1	GCE2 GCE2	GCE3 GCE4	GCE4 GCE5	GCE6 GCE8
R4-5A R4-7.5A	5 7.5	150.0 100.0	5.3 8.0	GCE2 GCE2	GCE3 GCE4	GCE5 GCE6	GCE8 GCE10	GCE10 GCE15
R4-10A R4-15A	10 15	75.0 50.0	11.0 16.0	GCE2 GCE3	GCE5 GCE8	GCE8 GCE12	GCE15 GCE24	GCE18 GCE24
R4-20A R4-25A	20 25	38.0 30.0	21.0 27.0	GCE4 GCE5	GCE10 GCE12	GCE18 GCE18	GCE24 GCE30	GCE30 EE2
R4-30A R4-40A	30 40	25.0 19.0	32.0 42.0	GCE6 GCE8	GCE12 GCE15	GCE18 GCE24	GCE30 EE3	EE3 EE3
R4-50A R4-60A	50 60	15.0 12.6	53.0 63.0	GCE8 GCE8	GCE18 GCE24	GCE30 EE2	EE3 EE3	EE4 EE4
R4-75A R4-100A	75 100	10.0 7.5	80.0 110.0	GCE9 GCE15	GCE30 GCE30	EE3 EE3	EE4 EE4	EE6 EE6
R4-125A R4-150A	125 150	6.0 5.0	130.0 160.0	GCE18 GCE18	EE3 EE3	EE4 EE4	EE4 EE6	EE8 EE8
R4-200A R4-250A	200 250	3.8 3.0	210.0 270.0	GCE24 GCE30	EE3 EE4	EE6 EE8	EE9 EE9	(2)EE6 (2)EE8
R4-300A R4-350A	300 350	2.5 2.2	320.0 360.0	GCE30 GCE30	EE4 EE6	EE8 EE8	(2)EE7 (2)EE7	(2)EE8 (3)EE8
R4-400A R4-500A	400 500	1.9 1.5	420.0 530.0	EE3 EE4	EE6 EE8	EE9 EE9	(3)EE7 (3)EE7	(3)EE8 (4)EE8

# Braking Resistors for 460 Volt Drives - 150% Braking Torque

**RATINGS:** Powerohm braking resistors are available in either 100% or 150% braking torque and (5) duty cycles based on a cycle time of one minute. Powerohm braking resistors are designed for a 375°C temperature rise when operating at the maximum rated duty cycle. The resistance values are measured at 25°C and have a + 10% tolerance.

**CAUTION:** It is very important to insure that the resistance listed in the chart below is greater than the minimum specified for your drive or braking module. Installing a braking resistor with too low of a resistance value will cause permanent damage to your drive or braking module. Please call the factory if you need assistance.

MAXIMUM BRAKING TIMES OF DUTY CYCLES		
Duty Cycle	Maximum Braking Time	
	Overhauling Load	Deceleration Braking
10%	6 sec.	12 sec.
20%	12 sec.	24 sec.
30%	18 sec.	36 sec.
50%	30 sec.	Continuous
100%	Continuous	Continuous

## BRAKING RESISTORS FOR 460V DRIVES REQUIRING 150% BRAKING TORQUE

PART NO. PREFIX	H.P.	OHMS	BRAKING AMPS	ENCLOSURE REQUIRED FOR SPECIFIED DUTY CYCLE				
				10% DUTY	20% DUTY	30% DUTY	50% DUTY	100% DUTY
R4-.5B R4-.75B	.50 .75	1000.0 675.0	0.8 1.2	GCE1 GCE1	GCE1 GCE1	GCE1 GCE1	GCE1 GCE2	GCE2 GCE3
R4-1B R4-1.5B	1 1.5	500.0 335.0	1.6 2.4	GCE1 GCE1	GCE1 GCE2	GCE2 GCE3	GCE2 GCE4	GCE4 GCE6
R4-2B R4-3B	2 3	250.0 170.0	3.2 4.7	GCE1 GCE1	GCE2 GCE3	GCE4 GCE5	GCE5 GCE8	GCE8 GCE9
R4-5B R4-7.5B	5 7.5	100.0 67.0	8.0 12.0	GCE2 GCE3	GCE4 GCE6	GCE8 GCE10	GCE10 GCE15	GCE15 GCE24
R4-10B R4-15B	10 15	50.0 34.0	16.0 24.0	GCE3 GCE4	GCE8 GCE12	GCE12 GCE18	GCE24 GCE24	GCE24 GCE30
R4-20B R4-25B	20 25	25.0 20.0	32.0 40.0	GCE6 GCE8	GCE12 GCE15	GCE18 GCE24	GCE30 EE2	EE3 EE3
R4-30B R4-40B	30 40	17.0 12.6	47.0 63.0	GCE9 GCE9	GCE15 GCE24	GCE30 EE2	EE3 EE3	EE3 EE4
R4-50B R4-60B	50 60	10.0 8.4	80.0 95.0	GCE9 GCE15	GCE30 GCE30	EE3 EE3	EE4 EE5	EE6 EE6
R4-75B R4-100B	75 100	6.7 5.0	120.0 160.0	GCE15 GCE18	EE2 EE3	EE4 EE4	EE5 EE8	EE8 (2)EE6
R4-125B R4-150B	125 150	4.0 3.4	200.0 235.0	GCE24 GCE24	EE3 EE4	EE5 EE6	(2)EE5 (2)EE5	(2)EE6 (2)EE8
R4-200B R4-250B	200 250	2.5 2.0	320.0 400.0	GCE30 EE3	EE6 EE6	EE8 (2)EE5	(2)EE6 (2)EE6	(2)EE8 (3)EE8
R4-300B R4-350B	300 350	1.7 1.5	470.0 530.0	EE3 EE4	EE6 EE8	(2)EE5 (2)EE8	(3)EE7 (3)EE9	(4)EE8 (4)EE9
R4-400B R4-500B	400 500	1.3 1.0	610.0 800.0	EE4 EE5	EE8 (2)EE6	(2)EE8 (3)EE7	(4)EE8 (4)EE8	(4)EE9 (5)EE9

# Braking Resistors for 575 Volt Drives - 100% Braking Torque

## SPECIFY PART NUMBERS AS FOLLOWS: R5 -

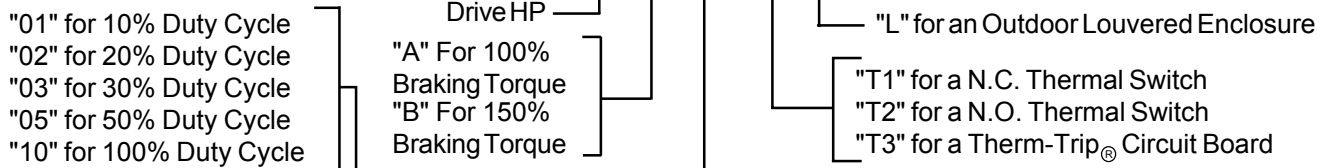

For example, the part number of a braking resistor rated for a 250 HP, 575V drive requiring 150% braking torque with a 10% duty cycle and an optional thermal switch with normally closed contacts is R5-250B01-T1.

**CONSTRUCTION:** Standard units include resistors installed in a screened enclosure with a galvanized finish. All enclosures are assembled with stainless steel hardware. Units are furnished with resistors wired to a terminal block with high temperature silicone or teflon wire. Refer to the Enclosure Section of the catalog for enclosure details and finish options.

## BRAKING RESISTORS FOR 575V DRIVES REQUIRING 100% BRAKING TORQUE

PART NO. PREFIX	H.P.	OHMS	BRAKING AMPS	ENCLOSURE REQUIRED FOR SPECIFIED DUTY CYCLE				
				10% DUTY	20% DUTY	30% DUTY	50% DUTY	100% DUTY
R5-.5A R5-.75A	.50 .75	2000.0 1500.0	0.5 0.7	GCE1 GCE1	GCE1 GCE1	GCE1 GCE1	GCE1 GCE1	GCE1 GCE2
R5-1A R5-1.5A	1 1.5	1200.0 800.0	0.8 1.3	GCE1 GCE1	GCE1 GCE1	GCE1 GCE2	GCE2 GCE2	GCE3 GCE4
R5-2A R5-3A	2 3	575.0 400.0	1.7 2.5	GCE1 GCE1	GCE1 GCE2	GCE2 GCE4	GCE3 GCE5	GCE6 GCE8
R5-5A R5-7.5A	5 7.5	235.0 150.0	4.3 6.7	GCE1 GCE2	GCE3 GCE4	GCE5 GCE6	GCE8 GCE10	GCE10 GCE15
R5-10A R5-15A	10 15	120.0 78.0	8.3 13.0	GCE3 GCE3	GCE5 GCE8	GCE8 GCE15	GCE15 GCE24	GCE24 GCE30
R5-20A R5-25A	20 25	59.0 47.0	17.0 21.0	GCE4 GCE5	GCE10 GCE12	GCE18 GCE24	GCE30 GCE30	GCE30 EE2
R5-30A R5-40A	30 40	39.0 29.0	26.0 34.0	GCE6 GCE8	GCE15 GCE15	GCE24 GCE30	GCE30 EE3	EE3 EE3
R5-50A R5-60A	50 60	23.0 20.0	43.0 50.0	GCE9 GCE12	GCE18 GCE24	GCE30 EE2	EE3 EE4	EE4 EE5
R5-75A R5-100A	75 100	15.6 11.7	64.0 85.0	GCE12 GCE15	GCE30 EE2	EE3 EE3	EE4 EE4	EE5 EE7
R5-125A R5-150A	125 150	9.3 7.8	110.0 130.0	GCE18 GCE18	EE2 EE3	EE4 EE4	EE6 EE6	EE8 (2)EE5
R5-200A R5-250A	200 250	5.9 4.7	170.0 210.0	GCE24 GCE24	EE3 EE3	EE4 EE6	EE9 (2)EE6	(2)EE7 (2)EE8

# Braking Resistors for 575 Volt Drives - 150% Braking Torque

**RATINGS:** Powerohm braking resistors are available in either 100% or 150% braking torque and (5) duty cycles based on a cycle time of one minute. Powerohm braking resistors are designed for a 375°C temperature rise when operating at the maximum rated duty cycle. The resistance values are measured at 25°C and have a + 10% tolerance.

**CAUTION:** It is very important to insure that the resistance listed in the chart below is greater than the minimum specified for your drive or braking module. Installing a braking resistor with too low of a resistance value will cause permanent damage to your drive or braking module. Please call the factory if you need assistance.

MAXIMUM BRAKING TIMES OF DUTY CYCLES		
Duty Cycle	Maximum Braking Time	
	Overhauling Load	Deceleration Braking
10%	6 sec.	12 sec.
20%	12 sec.	24 sec.
30%	18 sec.	36 sec.
50%	30 sec.	Continuous
100%	Continuous	Continuous

## BRAKING RESISTORS FOR 575V DRIVES REQUIRING 150% BRAKING TORQUE

PART NO. PREFIX	H.P.	OHMS	BRAKING AMPS	ENCLOSURE REQUIRED FOR SPECIFIED DUTY CYCLE				
				10% DUTY	20% DUTY	30% DUTY	50% DUTY	100% DUTY
R5-.5B R5-.75B	.50 .75	1500.0 1000.0	0.7 1.0	GCE1 GCE1	GCE1 GCE1	GCE1 GCE1	GCE1 GCE2	GCE2 GCE3
R5-1B R5-1.5B	1 1.5	800.0 525.0	1.3 1.9	GCE1 GCE1	GCE1 GCE2	GCE2 GCE2	GCE2 GCE4	GCE4 GCE6
R5-2B R5-3B	2 3	400.0 260.0	2.5 3.8	GCE1 GCE1	GCE2 GCE3	GCE4 GCE6	GCE6 GCE8	GCE9 GCE10
R5-5B R5-7.5B	5 7.5	160.0 100.0	6.3 10.0	GCE2 GCE3	GCE4 GCE6	GCE8 GCE9	GCE12 GCE18	GCE15 GCE24
R5-10B R5-15B	10 15	80.0 52.0	13.0 19.0	GCE3 GCE4	GCE8 GCE12	GCE15 GCE18	GCE24 GCE30	GCE30 GCE30
R5-20B R5-25B	20 25	39.0 32.0	26.0 31.0	GCE6 GCE8	GCE15 GCE15	GCE18 GCE24	GCE30 EE2	EE3 EE4
R5-30B R5-40B	30 40	26.0 20.0	38.0 50.0	GCE9 GCE12	GCE18 GCE24	GCE30 EE2	EE3 EE3	EE4 EE5
R5-50B R5-60B	50 60	16.0 13.0	63.0 77.0	GCE12 GCE12	GCE30 GCE30	EE3 EE3	EE4 EE4	EE5 EE5
R5-75B R5-100B	75 100	10.4 7.8	96.0 130.0	GCE18 GCE18	EE2 EE3	EE3 EE4	EE6 EE6	EE7 (2)EE5
R5-125B R5-150B	125 150	6.3 5.2	160.0 190.0	GCE24 GCE30	EE3 EE4	EE5 EE6	EE8 (20)EE6	(2)EE6 (2)EE7
R5-200B R5-250B	200 250	3.9 3.2	150.0 310.0	GCE30 GCE30	EE5 EE5	EE9 EE9	(2)EE6 (2)EE8	(2)EE9 (3)EE7

# Protective Over-Temperature Options

Powerohm braking resistors are available with several options for sensing an over-temperature condition. When an over-temperature condition occurs, it may be necessary to remove power from the braking resistor or the drive. The thermal switch may be used to provide an over-temperature alarm control signal.

## THERMAL SWITCHES - OPTION "T1" & "T2"



**Option "T1":** Includes a normally closed thermal switch for sensing an over-temperature condition. Option includes the over-temperature switch installed in the terminal compartment of the Type GCE enclosure or wired to a terminal block located in the bottom of a Type EE enclosure.

**Option "T2":** Includes a normally open thermal switch for sensing an over-temperature condition. Option includes the over-temperature switch installed in the terminal compartment of the Type GCE enclosure or wired to a terminal block located in the bottom of a Type EE enclosure.

**Output Terminals:** Includes (2) 1/4 inch quick-connecting terminals.

**Output Electrical Ratings:** 120VAC/ 10A or 240VAC/ 5A

## THERM-TRIP<sup>®</sup> CIRCUIT BOARD - OPTION "T3"

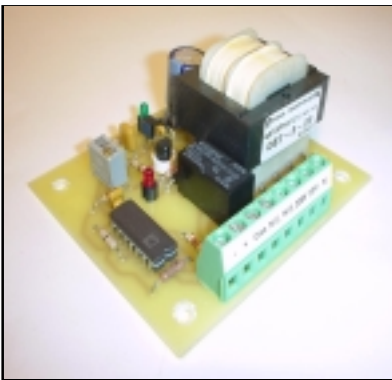

**Option "T3":** Includes our Therm-Trip<sup>®</sup> circuit board with a K type thermocouple input to sense an over-temperature condition. This open circuit board monitors the temperature of the resistor elements in real time. Option includes the circuit board installed in our Type GCE or EE enclosures, complete with the thermocouple welded directly to the resistor elements.

**Control Power:** Either 115VAC or 230VAC power required (<1.5VA).

**Temperature Setpoint:** Factory set at 500°C (adjustable from 50 to 600°C).

**Indicators:** Green LED indicates control power present.

Red LED indicates temperature input exceeds setpoint.

**Terminals:** Accepts wire sizes 22-14AWG.

**Output Contacts:** Form C relay provides both N.O. and N.C. contacts.

**Output Electrical Ratings:** 120VAC/ 0.5A or 24VDC/ 1.0A



# Motor Control Applications

## INTRODUCTION

Motor control is one of the most common applications of power resistors. Resistors are used to control the torque and speed characteristics of AC and DC motors, and to limit inrush currents.

This section provides a basic understanding of how resistors are used for motor control, and the information required to design a resistor configuration. To order a resistor assembly, simply obtain the data needed for your motor type and call the factory. Our engineers will design a package that best suits your needs.

## AC WOUND ROTOR INDUCTION MOTOR

In wound rotor motors, the conductors in the rotor (or secondary) are connected to slip rings. The internal brushes make electrical contact with the slip rings and are connected to an external resistor circuit. By varying the external resistance, the rotor current can be changed to control the starting torque and speed of the motor to meet the requirements of any installation.

### Data Requirements:

- Application
- Secondary Amps
- Horsepower
- NEMA Class
- Secondary Volts
- Number of Speeds

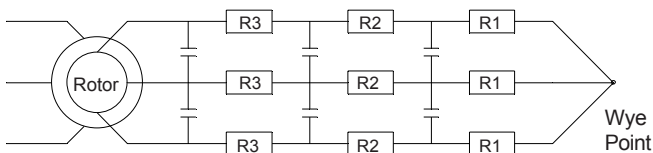

Typical Resistor Control Schematic  
for an AC Wound Rotor Motor  
3 Step/ 4 Speed

## DC SERIES WOUND MOTOR

Conductor current in DC motors is produced by an applied voltage to the armature coils (in DC motors the rotating part is called the armature, in AC motors it is called the rotor). Resistors are used to limit the current flow to the motor to control torque and speed characteristics.

### Data Requirements:

- Application
- Full Load Amps
- Horsepower
- NEMA Class
- Normal Line Voltage
- Number of Speeds

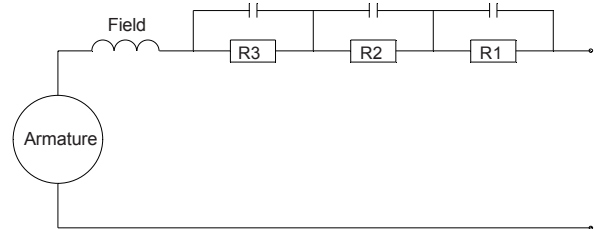

Typical Resistor Control Schematic  
for a DC Series Wound Motor  
3 Step/ 4 Speed

## AC SQUIRREL CAGE MOTOR

In squirrel cage motors, the conductors in the rotor slots are shorted at the ends. Therefore, the resistance of the conductors is fixed and cannot be changed. However, resistors can be connected in-line with the motor to reduce the starting voltage. During the acceleration period at the moment a motor is started, it draws a high "inrush" current. Resistors can be used to reduce the full line, starting voltage applied to the motor. Commonly known as a ballast resistor, the resistor acts as a voltage divider and reduces the inrush current, providing a "soft start." Standard designs for small horsepower motors can be found on the following page.

### Data Requirements:

- Application
- Full Load Amps
- Horsepower
- NEMA Class
- Normal Line Voltage

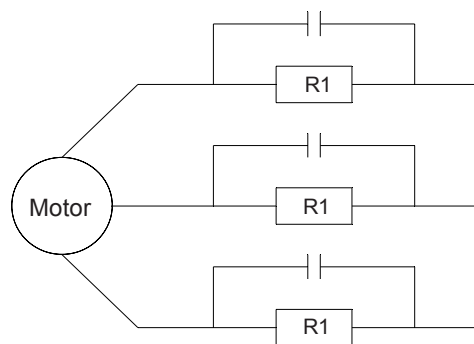

Typical Resistor Control Schematic  
for an AC Squirrel Cage Motor

# Standard Motor Control Designs

The following table contains standard designs for three-phase adjustable ballast resistors. Contact the factory for information on motors not listed in the table.

3-PHASE ADJUSTABLE BALLASTS FOR SMALL SQUIRREL CAGE MOTORS								
CATALOG NUMBER	MOTOR H.P.	MOTOR AMPS	OHMS PER PHASE	DIMENSIONS IN INCHES				
				A	B	C	D	E
<b>230 VOLTS</b>								
BR230-50	1/2	2.0	19.9	12	10	5	11-1/8	7-1/2
BR230-75	3/4	2.8	14.2	12	10	5	11-1/8	7-1/2
BR230-100	1	3.6	11.1	12	10	5	11-1/8	7-1/2
BR230-150	1-1/2	5.2	7.7	12	10	5	11-1/8	7-1/2
BR230-200	2	6.8	5.9	12	10	5	11-1/8	7-1/2
BR230-300	3	9.6	4.1	12	10	5	11-1/8	7-1/2
BR230-500	5	15.2	2.6	19	10	5	18-1/8	7-1/2
BR230-750	7-1/2	22.0	1.8	19	10	5	18-1/8	7-1/2
BR230-1000	10	28.0	1.4	19	10	5	18-1/8	7-1/2
<b>460 VOLTS</b>								
BR460-50	1/2	1.0	79.9	12	10	5	11-1/8	7-1/2
BR460-75	3/4	1.4	56.9	12	10	5	11-1/8	7-1/2
BR460-100	1	1.8	44.3	12	10	5	11-1/8	7-1/2
BR460-150	1-1/2	2.6	30.6	12	10	5	11-1/8	7-1/2
BR460-200	2	3.4	23.4	12	10	5	11-1/8	7-1/2
BR460-300	3	4.8	16.6	12	10	5	11-1/8	7-1/2
BR460-500	5	7.6	10.5	19	10	5	18-1/8	7-1/2
BR460-750	7-1/2	11.0	7.2	19	10	5	18-1/8	7-1/2
BR460-1000	10	14.0	5.7	19	10	5	18-1/8	7-1/2
<b>575 VOLTS</b>								
BR575-50	1/2	0.8	124.5	12	10	5	11-1/8	7-1/2
BR575-75	3/4	1.1	90.5	12	10	5	11-1/8	7-1/2
BR575-100	1	1.4	71.1	12	10	5	11-1/8	7-1/2
BR575-150	1-1/2	2.1	47.4	12	10	5	11-1/8	7-1/2
BR575-200	2	2.7	36.9	12	10	5	11-1/8	7-1/2
BR575-300	3	3.9	25.5	12	10	5	11-1/8	7-1/2
BR575-500	5	6.1	16.3	19	10	5	18-1/8	7-1/2
BR575-750	7-1/2	9.0	11.1	19	10	5	18-1/8	7-1/2
BR575-1000	10	11.0	9.1	19	10	5	18-1/8	7-1/2

**CONSTRUCTION:** Powerohm's three-phase adjustable ballast resistors feature our quality resistor elements assembled in our GLE enclosures. Our durable GLE enclosures have a mill galvanized finish. Contact the factory for special space constraints, etc.

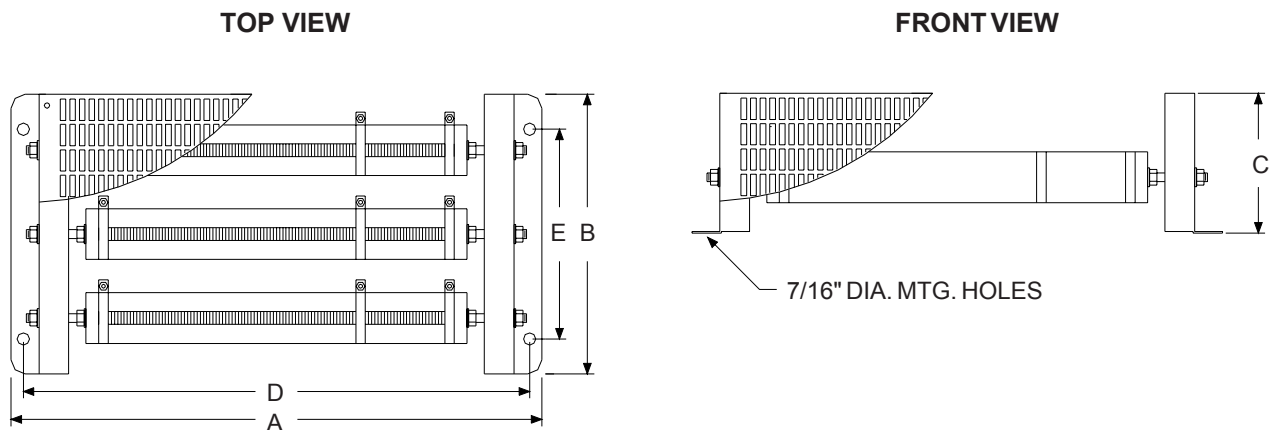

# Standard Motor Control Designs

## WYE-DELTA STARTING RESISTORS

**WYE-DELTA TYPE STARTERS (CLOSED TRANSITION):** In the case of a wye-delta closed transition type starter, a set of resistors is connected to the motor winding before the delta contactor is closed. These resistors are used to balance the back EMF of the motor and the line voltage before closing the delta contactor. Closed transition eliminates the surge current that occurs when transferring the motor from wye to delta connection, thus providing a smoother acceleration of the motor from reduced voltage to full voltage.

### Data Requirements:

- Horsepower
- Full Load Amps
- Normal Line Voltage

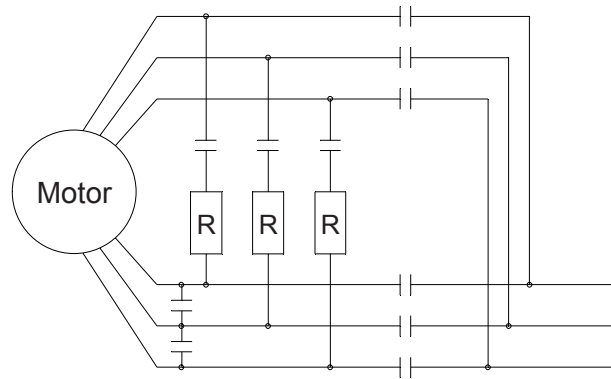

Typical Control Schematic for a Wye-Delta Starter (Closed Transition)

## RESISTOR DESIGNS FOR WYE-DELTA STARTERS (CLOSED TRANSITION)

CATALOG NUMBER	MOTOR H.P.	MOTOR AMPS	OHMS PER PHASE	CATALOG NUMBER	MOTOR H.P.	MOTOR AMPS	OHMS PER PHASE
<b>230 VOLTS</b>				<b>380 VOLTS</b>			
WD230-10	10	28	4.70	WD380-10	10	17	13.00
WD230-15	15	42	3.20	WD380-15	15	25	8.60
WD230-20	20	54	2.50	WD380-20	20	33	6.70
WD230-25	25	68	1.90	WD380-25	25	41	5.30
WD230-30	30	80	1.70	WD380-30	30	48	4.50
WD230-40	40	104	1.30	WD380-40	40	63	3.50
WD230-50	50	130	1.00	WD380-50	50	79	2.80
WD230-60	60	154	0.85	WD380-60	60	93	2.40
WD230-75	75	192	0.70	WD380-75	75	116	1.90
WD230-100	100	248	0.55	WD380-100	100	150	1.50
<b>460 VOLTS</b>				<b>575 VOLTS</b>			
WD460-10	10	14	19.00	WD575-10	10	11	30.00
WD460-15	15	21	12.70	WD575-15	15	17	19.50
WD460-20	20	27	9.90	WD575-20	20	22	15.00
WD460-25	25	34	7.80	WD575-25	25	27	12.30
WD460-30	30	40	6.60	WD575-30	30	32	10.40
WD460-40	40	52	5.10	WD575-40	40	41	8.10
WD460-50	50	65	4.00	WD575-50	50	52	6.40
WD460-60	60	77	3.50	WD575-60	60	62	5.40
WD460-75	75	96	2.80	WD575-75	75	77	4.30
WD460-100	100	124	2.10	WD575-100	100	99	3.40

**CONSTRUCTION:** For most applications, the resistors are mounted in the upper section of the motor control cabinet. Therefore, all of the above standard designs consist of three WR Type resistor coils mounted on open style Type B3 brackets. These brackets have a mill galvanized finish.

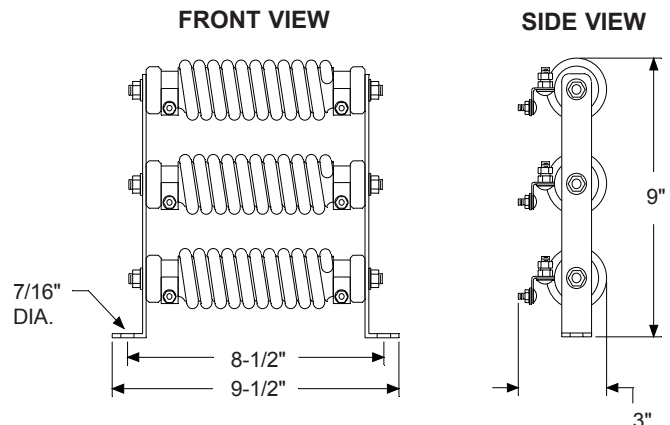

# NEMA Standards for Motor Control Resistors

The following table is for selecting the NEMA Class for an application in relation to starting torque and duty cycle.

## NEMA CLASSIFICATION OF RESISTORS

Approximate Percent of Full-Load Current on First Point Starting @ Rest	CLASS NUMBERS APPLYING TO DUTY CYCLES							
	30 sec. on out of each 15 min.	5 sec. on out of each 80 sec.	10 sec. on out of each 80 sec.	15 sec. on out of each 90 sec.	15 sec. on out of each 60 sec.	15 sec. on out of each 45 sec.	15 sec. on out of each 30 sec.	Continuous Duty
25	101	111	131	141	151	161	171	91
50	102	112	132	142	152	162	172	92
70	103	113	133	143	153	163	173	93
100	104	114	134	144	154	164	174	94
150	105	115	135	145	155	165	175	95
200 or over	106	116	136	146	156	166	176	96

The following table contains standard NEMA Classification Numbers for a variety of applications. Although these classification numbers have been found to be correct for an average installation, there will be exceptions.

## NEMA RESISTOR APPLICATION STANDARDS

APPLICATION	NEMA CLASS	APPLICATION	NEMA CLASS	APPLICATION	NEMA CLASS
Blowers		Food Plants		Rubber Mills	
Centrifugal.....	133-93	Butter Chums, Dough Mixer.....	135	Banbury, Crackers.....	135
Constant Pressure.....	135-95	Hoists		Calenders.....	155
Brick Plants		Winch.....	153	Mixing Mills, Washers.....	135
Augers, Conveyors.....	135	Mine Slope.....	172	Steel Mills	
Dry Pans, Pug Mills		Mine Vertical.....	162	Accumulators.....	153
By-product Coke Plants		Contractor's Hoists.....	152	Casting Machines-Pig.....	153
Door Machine, Leveler Ram.....	153	Larry Cars.....	153	Charging Machines	
Pusher Bar, Valve Reversing		Lift Bridges.....	152	Bridge.....	153 or 163
Machines		Machine Tools		Peel.....	153 or 163
Cement Mills		Bending Rolls.....	163 or 164	Trolley.....	153 or 163
Conveyors.....	135	Boring Mills.....	135	Coiling Machines.....	135
Crushers.....	145	Bulldozers.....	135	Converters-Metal.....	154
Elevators.....	135	Drills, Gear Cutters.....	115	Conveyors.....	135-155
Rotary Dryers.....	145-95	Grinders.....	135	Crushers.....	145
Grinders and Pulverizers.....	135	Hobbing Machines, Lathes.....	115	Furnace Door, Gas Valves.....	155
Kilns.....	135-95	Milling Machines		Gas Washers	
Coal and Ore Bridges		Presses, Punches.....	135	Hot Metal Mixers.....	163
Bridge.....	153	Saws, Shapers.....	115	Ingot Buggy, Kickoff.....	153
Closing, Holding.....	162	Metal Mining		Levelers	
Trolley.....	162 or 163	Ball, Rod and Tube Mills.....	135	Manipulator Fingers.....	153 or 163
Coal Mines		Car Dumpers-Rotary.....	153	Pickling Machine.....	153
Car Hauls.....	162	Converters-Copper.....	154	Pilars-Slab, Racks	
Conveyors.....	135 or 155	Conveyors.....	135	Reelers.....	135
Cutters.....	135	Crushers.....	145	Saws-Hot or Cold.....	155
Crushers.....	145	Tilting Furnace.....	153	Screw Downs.....	153 or 163
Fans.....	134 or 95	Paper Mills		Shears, Shuffle Bars.....	155
Hoists		Beaters.....	135	Side Guards.....	153 or 163
Slope.....	172	Calenders.....	154-92	Sizing Rolls, Slab Buggy.....	155
Vertical.....	162	Chippers.....	145	Soaking Pit Covers	
Jigs, Picking Tables.....	135	Pipeworking		Straighteners.....	153
Rotary Car Dumpers.....	153	Cutting and Threading.....	135	Tables	
Shaker Screens.....	135	Expanding and Flanging.....	135-95	Approach.....	153
Compressors		Power Plants		Lift.....	153 or 163
Constant Speed.....	135	Clinker Grinders.....	135	Main Roll.....	153 or 163
Varying Speed		Coal Crushers.....	135	Roll.....	153
Centrifugal.....	93	Conveyors		Shear Approach.....	153 or 163
Plunger Type.....	95	Belt, Screw.....	135	Transfer.....	153
Concrete Mixers.....	135	Pulverized Fuel Feeders.....	135	Tilting Furnace.....	153
Cranes-General Purpose		Pulverizers		Wire Stranding Machine.....	153
Hoist.....	153-163	Ball Type.....	135	Woodworking Plants	
Bridge or Trolley with		Centrifugal.....	134	Boring Machines, Lathe.....	115
Sleeve Bearings.....	153-163	Stokers.....	135-93	Mortiser, Moulder, Planers,	
Roller Bearings.....	152-162	Pumps		Power Trimmer and Mitre,	
Flour Mills		Centrifugal.....	134-93	Sanders, Saws, Shapers,	
Line Shafting.....	135	Plunger.....	135-95	Shingle Machine	

**24 HOUR EMERGENCY SERVICE**

**(800) 838-4694**

# Type NR Neutral Grounding Resistors

## APPLICATION

Powerohm Type NR Neutral Grounding Resistors are used in industrial power systems for resistance grounding of wye-connected generators and transformers. A neutral grounding resistor limits the fault current to a value which is sufficient enough to operate protective relays, yet prevent unwanted fault damage.

### Neutral Grounding Resistor Schematic

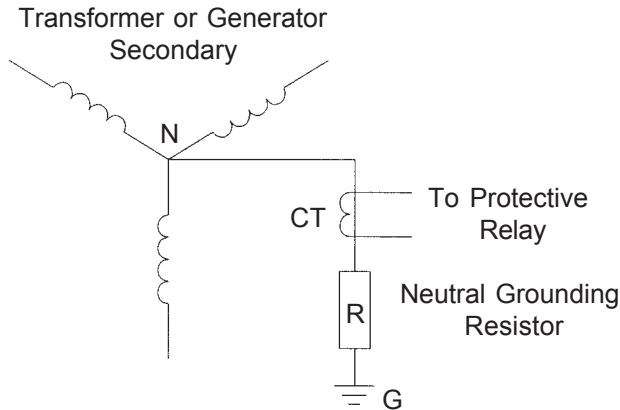

## DESIGN REQUIREMENTS

Neutral grounding resistors are rated in line-to-neutral voltage (system voltage divided by 1.732), initial fault current and maximum time on. Powerohm neutral grounding resistors are designed to dissipate the required amount of energy and not exceed the temperature limitations of IEEE Standard 32-1972. As defined in this publication, the time and temperature ratings for neutral grounding resistors are as follows:

**Short time:** Short time ratings are 10 and 60 seconds. Since short time rated resistors can only withstand rated current for short periods of time, they are usually used with fault clearing relays. The short time temperature rise for the resistive element is 760°C.

**Extended time:** A time on rating greater than ten minutes which permits temperature rise of resistive elements to become constant, but limited to an average not more than 90 days per year. The extended temperature rise for the resistive element is 610°C.

**Continuous:** Capable of withstanding rated current for an indefinite period of time. The continuous temperature rise for the resistive element is 385°C.

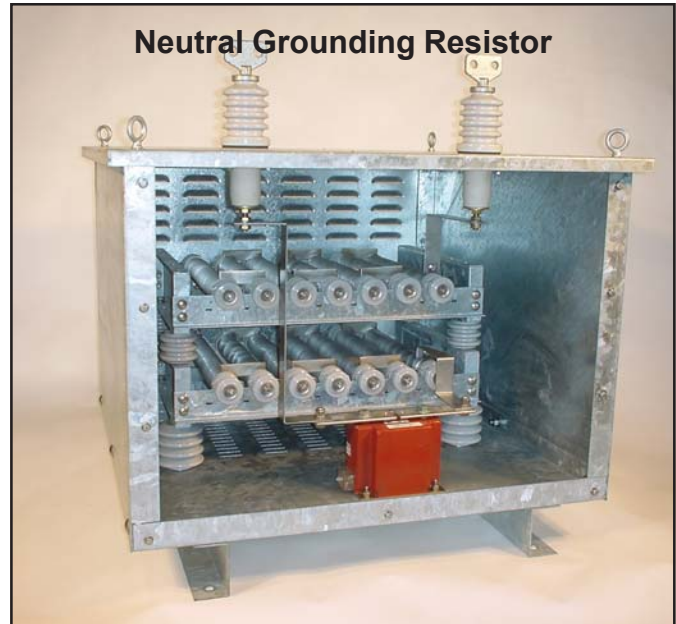

## BASIC CONSTRUCTION

**Resistor Assembly:** The resistor coils consist of a stainless steel edgewound element wound around a ceramic core supported on a through-rod. Glazed insulators are attached to each end of the coils and fastened to a heavy gage, corrosion resistant frame. The unit is designed to permit the expansion of supporting rods when submitted to high operating temperatures. Resistor elements are joined by stainless steel connectors, which are welded in place, to form a positive electrical path.

**Safety Enclosure:** Our resistor assemblies are available with grounded safety enclosures to protect personnel and wildlife from harm. Screened and louvered enclosures are available in a variety of finishes including painted, powder coated, mill galvanized, hot-dipped galvanized, aluminum and stainless steel.

**Options:** A number of additional options are available including entrance bushings, current transformers, elevating stands and disconnect switches.

## ELECTRICAL TESTS

All units are factory tested in accordance with IEEE Standard 32-1972, specifically Sections 10.1.4 and 10.3.2. The procedure includes a resistance measurement test to verify that the tolerance is within + 10%, and an applied potential test. A copy of the test report is included with each shipped unit.



# Ratings & Dimensions of Standard Size Units

**RATINGS:** The following table contains information on the most common size units, other variations are available.

**DIMENSIONS:** The dimensions listed in the table are in inches. Information subject to change without notice.

## 10 SECOND TIME RATINGS

CATALOG NUMBER	INITIAL AMPS	RESISTANCE	A	B	C	APPROX. WEIGHT
1390 VOLTS LINE-TO-NEUTRAL (2400 VOLT SYSTEM)						
NR1390-100-10	100	13.90	38	38	30	280
NR1390-200-10	200	6.95	38	38	30	290
NR1390-300-10	300	4.63	38	38	30	300
NR1390-400-10	400	3.48	38	38	30	310
NR1390-500-10	500	2.78	38	38	30	320
NR1390-600-10	600	2.32	38	38	30	340
NR1390-800-10	800	1.74	38	38	30	350
NR1390-1000-10	1000	1.39	38	38	30	360

## 2400 VOLTS LINE-TO-NEUTRAL (4160 VOLT SYSTEM)

NR2400-100-10	100	24.00	38	38	30	380
NR2400-200-10	200	12.00	38	38	30	390
NR2400-300-10	300	8.00	38	38	30	400
NR2400-400-10	400	6.00	38	38	30	410
NR2400-500-10	500	4.80	38	38	30	420
NR2400-600-10	600	4.00	38	38	30	430
NR2400-800-10	800	3.00	38	38	36	490
NR2400-1000-10	1000	2.40	38	38	36	500

## 4160 VOLTS LINE-TO-NEUTRAL (7200 VOLT SYSTEM)

NR4160-100-10	100	41.60	38	38	36	550
NR4160-200-10	200	20.80	38	38	36	560
NR4160-300-10	300	13.87	38	38	36	570
NR4160-400-10	400	10.40	38	38	36	580
NR4160-500-10	500	8.32	38	38	36	590
NR4160-600-10	600	6.93	38	38	36	600
NR4160-800-10	800	5.20	44	54	54	680
NR4160-1000-10	1000	4.16	44	54	54	700

## 8000 VOLTS LINE-TO-NEUTRAL (13800 VOLT SYSTEM)

NR8000-100-10	100	80.00	44	54	54	820
NR8000-200-10	200	40.00	44	54	54	830
NR8000-300-10	300	26.70	44	54	54	840
NR8000-400-10	400	20.00	44	54	54	850
NR8000-500-10	500	16.00	44	54	54	870
NR8000-600-10	600	13.30	44	54	54	880
NR8000-800-10	800	10.00	44	54	84	950
NR8000-1000-10	1000	8.00	44	54	84	990

## EXTENDED TIME RATINGS

### 1390 VOLTS LINE-TO-NEUTRAL (2400 VOLT SYSTEM)

NR1390-15-E	15	92.7	38	38	30	320
NR1390-25-E	25	55.6	38	38	30	370
NR1390-50-E	50	27.8	38	38	36	420

### 2400 VOLTS LINE-TO-NEUTRAL (4160 VOLT SYSTEM)

NR2400-15-E	15	160.0	38	38	36	450
NR2400-25-E	25	96.0	38	38	36	550
NR2400-50-E	50	48.0	44	54	54	850

### 4160 VOLTS LINE-TO-NEUTRAL (7200 VOLT SYSTEM)

NR4160-15-E	15	227.3	44	54	54	900
NR4160-25-E	25	166.4	44	54	54	950
NR4160-50-E	50	83.2	84	54	54	1400

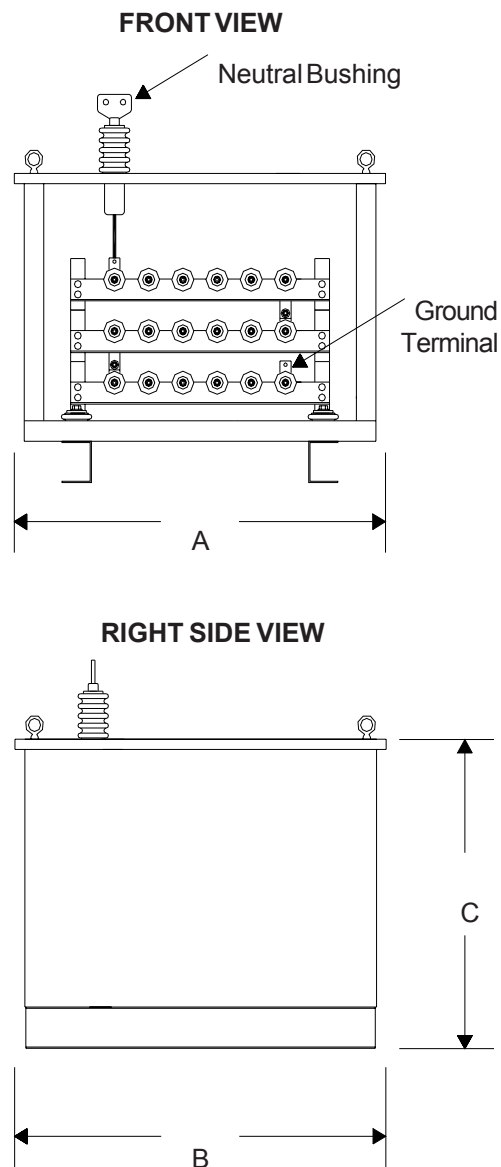

The above drawing details a typical neutral grounding resistor with enclosure. Units are available with screened or louvered covers on front and back. All units normally have solid tops and sides and a perforated bottom.

**TO ORDER A NEUTRAL GROUNDING RESISTOR NOT LISTED IN THE TABLE, SPECIFY THE FOLLOWING:**

1. Line-to-neutral voltage.
2. Initial fault current.
3. Maximum time on.
4. Special requirements or options.



# Generator Neutral Grounding Resistors

## APPLICATION

Powerohm offers high resistance grounding equipment for wye connected generators. Our equipment is normally designed to limit the line-to-ground fault current to below 15 amps for generators rated up to 14,400 volts. These units will provide a high resistance neutral during a fault condition, while allowing the system to operate as an ungrounded system during normal operating conditions. The configuration basically consists of a dry-type single-phase transformer with a resistor connected across the secondary. The primary of the transformer is then connected between the wye point of the generator and ground.

Powerohm generator grounding equipment is normally supplied with the transformer and resistor installed in a common enclosure. Continuous rated units are usually compartmentalized to separate the resistor assembly from the transformer which is subject to overheating. Units do not normally include any relaying or control circuitry, but do offer the transformer secondary wired to a terminal block installed in an external junction box.

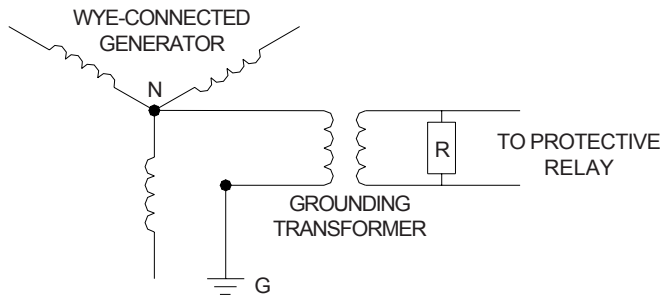

## BASIC CONSTRUCTION

**Transformer:** For continuous time ratings, the transformer must be capable of withstanding rated current for an indefinite period of time; therefore, the KVA rating of the grounding transformer is equal to the rated line-to-neutral voltage times the desired neutral current. For a short-time rating, the KVA rating of a grounding transformer will be smaller because the unit is designed to carry its rated current for a limited time.

**Resistor Assembly:** The resistance value is calculated by dividing the secondary voltage by the rated current necessary to obtain the desired fault current on the primary. Resistor elements are selected to best meet the current and voltage requirements of the system. A typical assembly includes all stainless steel elements, bus bars and terminals.

## Generator Neutral Grounding Resistor



**Safety Enclosure:** Our grounding assemblies are available in grounded NEMA 1 or NEMA 3R safety enclosures, complete with nearly any finish including mill galvanized, power coated, hot dipped galvanized after fabrication, aluminum or stainless steel.

**Options:** A number of additional options are available, including entrance bushings, current transformers, elevating stands, and disconnect switches.

## ELECTRICAL TESTS

All units are factory tested in accordance with IEEE Standard 32-1972, specifically Sections 10.1.4 and 10.3.2. The procedure includes a resistance measurement test to verify that the tolerance is within + 10%, and an applied potential test. A copy of the test report is included with each shipped unit.

# Resistance Grounding with a Zigzag Transformer

## APPLICATION

The best way to resistance ground a power system is to obtain the system neutral through a generator or transformer with a wye-connected winding. However, a system neutral may not be available, particularly in many older low voltage systems and a significant number of existing medium voltage systems. To avoid the high cost of replacing a source transformer, an existing delta-connected system can be grounded using a zigzag transformer to form an artificial neutral, then connecting a resistor between the newly created wye-point and ground.

A zigzag transformer has no secondary winding, and is designed to provide a low-impedance path for the zero-sequence currents to flow. During a line-to-ground fault condition, the zero sequence currents can flow into the ground at the point of the fault, and back through the neutral of the grounding transformer. The impedance of the zigzag transformer to balanced three-phase voltages is relatively high, therefore, when there is no fault on the system, only a small magnetizing current flows in the windings. A zigzag grounding transformer provides a stable neutral point which makes possible its use for grounding an otherwise isolated neutral system.

A zigzag transformer with a resistance ground is normally designed for a short time rating of 10 to 60 seconds. Consequently, the grounding transformer is much smaller in size than an ordinary continuously rated transformer with the same rating. For short time ratings, the short time temperature rise for the resistive element is 760°C.

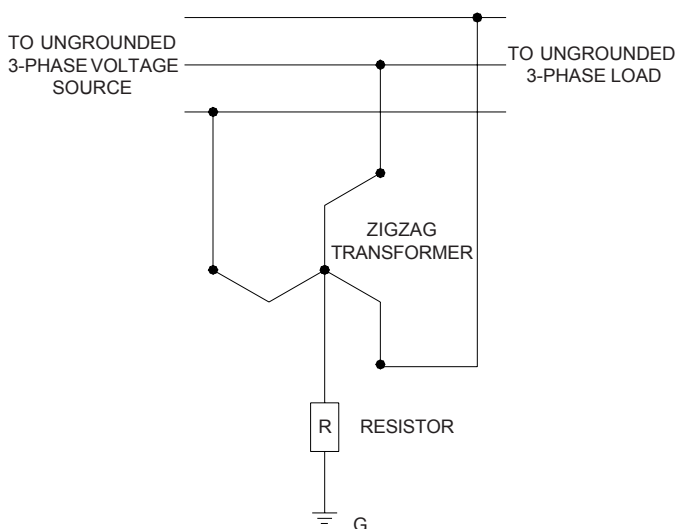

## Zigzag Grounding Transformer with Resistor



## BASIC CONSTRUCTION

**Transformer:** For a short time rating, the grounding transformer is designed to carry its rated current for a limited time, consequently the unit is ordinarily much smaller, physically, than an ordinary three-phase transformer for the same rated kVA.

**Resistor Assembly:** The resistance value is calculated by dividing the line-to-neutral voltage by the rated neutral current. Resistor elements are selected to best meet the short time current rating and voltage requirements of the system. A typical assembly includes all stainless steel elements, bus bars and terminals.

**Safety Enclosure:** Our grounding assemblies are available in grounded NEMA 1 or NEMA 3R safety enclosures, complete with nearly any finish, including mill galvanized, power coated, hot dipped galvanized after fabrication, aluminum, or stainless steel.

**Options:** A number of additional options are available including entrance bushings, current transformers, elevating stands and disconnect switches.

## ELECTRICAL TESTS

All units are factory tested in accordance with IEEE Standard 32-1972, specifically Sections 10.1.4 and 10.3.2. The procedure includes a resistance measurement test to verify that the tolerance is within + 10%, and an applied potential test. A copy of the test report is included with each shipped unit.

# Type HR High Resistance Grounding Systems

## APPLICATION

Powerohm Type HR High Resistance Grounding Systems are an economical means of improving a three-phase ungrounded power system by providing the following advantages:

**System Protection:** Offers protection by providing a ground-to-neutral connection for a three-phase power system, while still allowing to operate as an "ungrounded system." When the neutral of a system is not grounded, the system is vulnerable to potentially damaging ground faults.

**Transient Overvoltage Reduction:** A high resistance grounding system reduces the magnitude of high transient overvoltages appearing during normal switching of a circuit having a ground fault. High transient overvoltages may cause failure of equipment or insulation at locations on the system other than at the point of the fault.

**Ground Fault Detection Warning:** Instantly provides a warning when the first ground fault occurs through an alarm signal. An optional audible horn or red warning beacon is available.

**Ground Fault Location Simplified:** A pulsing contactor allows the ground fault location to be quickly located by use of a portable clamp-on current detector. The ease and swiftness of ground fault location eliminates the need to trace faults by opening and closing secondary feeders, branch circuits and individual loads one at a time.

**Uninterrupted Service:** A single line-to-ground fault left in operation may result in a second ground fault. If a second fault occurs on another phase before the first is removed, considerable damage may be caused by the relatively high line-to-line fault current. The potential for quickly locating and removing faults before damage occurs to critical processes minimizes outages, and costly manufacturing shutdowns.

**Improved Personnel Safety:** Reducing transient overvoltages, equipment arcing, fault levels, insulation failures and fault tracing through circuit isolation schemes decreases hazards to personnel.

## DESIGN REQUIREMENTS

**System Type and Voltage:** Standard high resistance grounding systems are available for both wye and delta systems (50 or 60 hertz). Standard units are rated for system voltages of 240, 480, 600, 2400, 3300 and 4160 volts.

**Current Rating:** Type HR grounding systems are available with standard current ratings ranging between 1 and 10 amps. Taps are provided to adjust current above the maximum system charging currents.

## High Resistance Grounding System



**Safety Enclosures:** Our high resistance grounding units are available in grounded safety enclosures with ratings of NEMA 1, 3R and 12. Standard low voltage units (600 volts or less) are installed in a wall-mounted enclosure with a floor-mounted enclosure as an option. Medium voltage units (2400 volts or higher) are available in a floor-mounted enclosure only. The standard finish is ANSI 61 grey.

**Resistor Assembly:** The resistor assembly is normally installed on top of our wall mounted or freestanding enclosures. Standard units consist of either wirewound or edgewound elements assembled with all stainless steel hardware in a screened or louvered enclosure. In some cases, optional provisions can be made to house resistors in remote enclosures or inside floor-mounted enclosures.

**Options:** A number of additional options are available to meet your special application. Contact the factory with your requirements or specification.



5713 13th Street  
Katy, Texas 77493  
Phone: (281) 391-6800, Fax: (281) 391-6810  
Please visit our website at [www.powerohm.com](http://www.powerohm.com)



# 2400, 3300 & 4160 Volt Wye or Delta Systems

## OPERATION DESCRIPTION

**Normal Operation:** Under normal operating conditions, when there is no ground fault present on the system and no current flowing through the resistor. An illuminated green indicating light, located on the front door, verifies normal operating conditions and proper control power.

**Ground Fault Condition:** During a ground fault condition a red indicating light, located on the front door, will illuminate and the alarm contacts will activate. The red indicating light and the alarm contacts will remain activated until the ground fault is removed. During a ground fault, voltage will appear across the resistor. The resistor includes multiple taps to adjust the fault current to a value slightly greater than the system magnetizing current. The resistance taps can be factory set or adjusted at time of equipment installation.

**Ground Fault Location:** To locate the ground fault, simply activate the pulse contactor by turning the selector switch, located on the front door, from the "Normal" position to the "Pulse" position. This activates a cycle of 40 pulses per minute to alternate the ground fault current between the set magnitude and zero. Maintenance personnel can then use a portable clamp-on ammeter to follow the fluctuating fault current through the system to the location of the fault source. After removing the ground fault, the selector switch is reset to stop the pulsing cycle. The green indicating light should illuminate to indicate that the system has returned to normal.

## FLOOR-MOUNTED DIMENSIONS

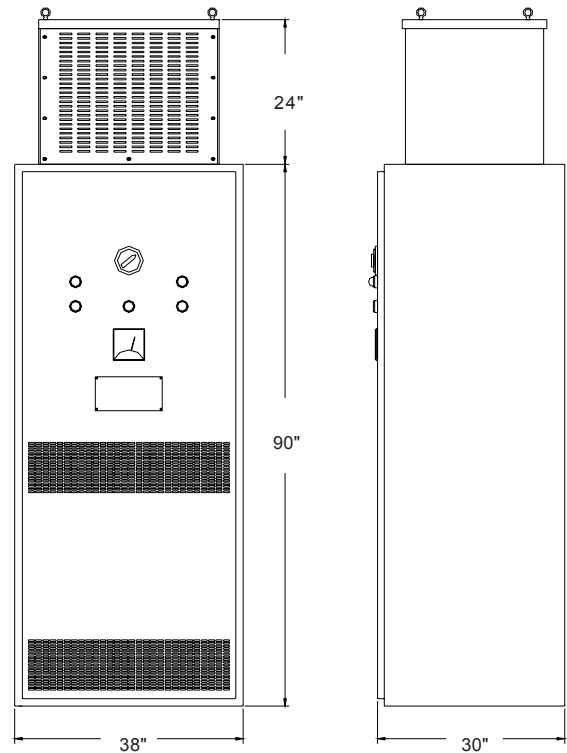

**STANDARD NEMA 1 FLOOR-MOUNTED ENCLOSURE**  
(NEMA 12 AND 3R HEIGHTS INCREASE BY 6 INCHES)

## MEDIUM VOLTAGE WYE SYSTEMS

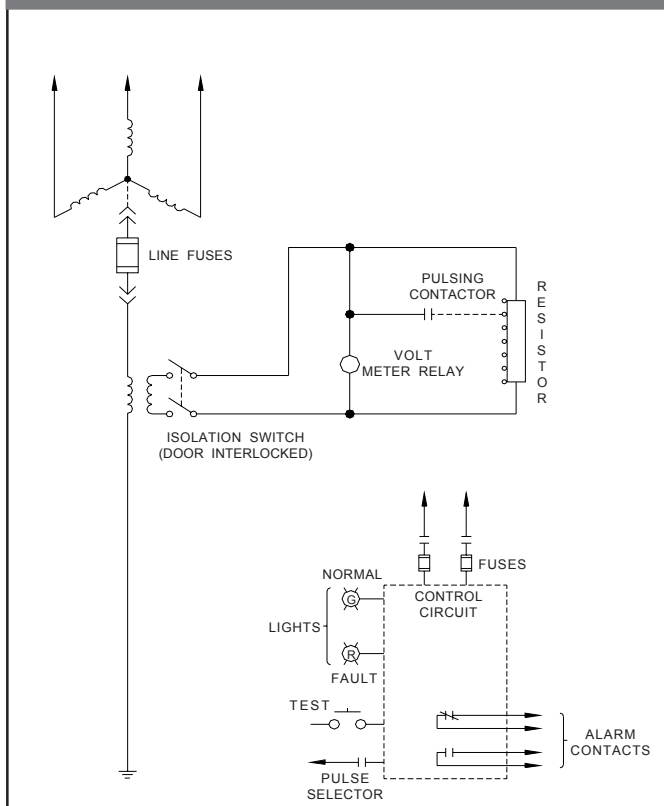

## MEDIUM VOLTAGE DELTA SYSTEMS

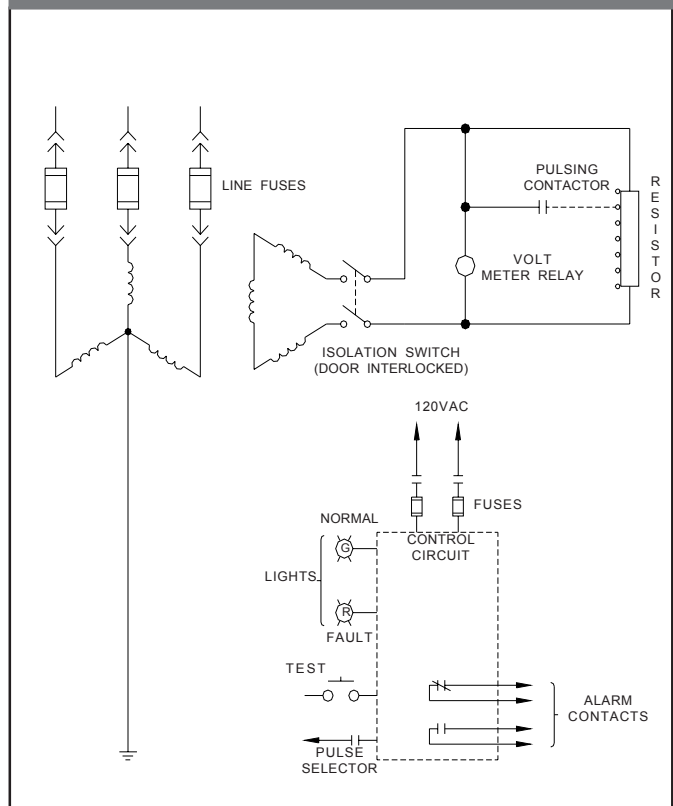

# 240, 480 and 600 Volt Wye or Delta Systems

## OPERATION DESCRIPTION

Powerohm's low and medium voltage units both have the same operating instructions. The overall size and layout is different, but the indicating lights and controls on the front door remain the same. Refer to the previous section for details.

## WALL-MOUNTED DIMENSIONS

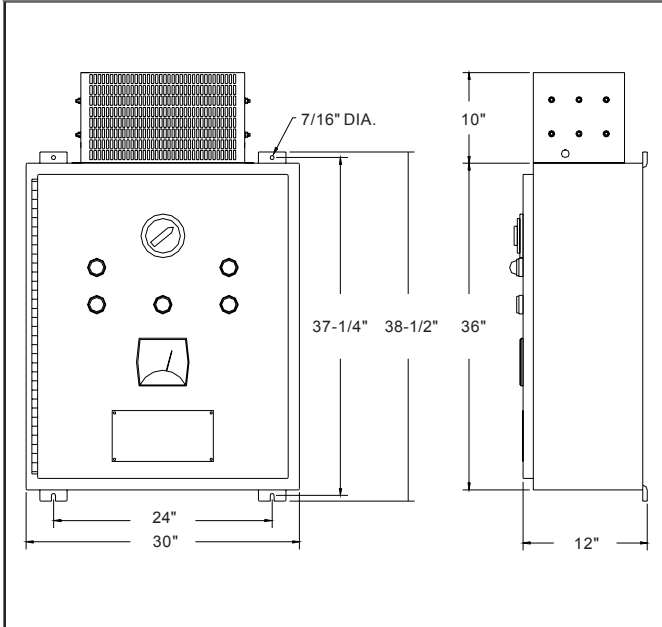

## FLOOR-MOUNTED DIMENSIONS

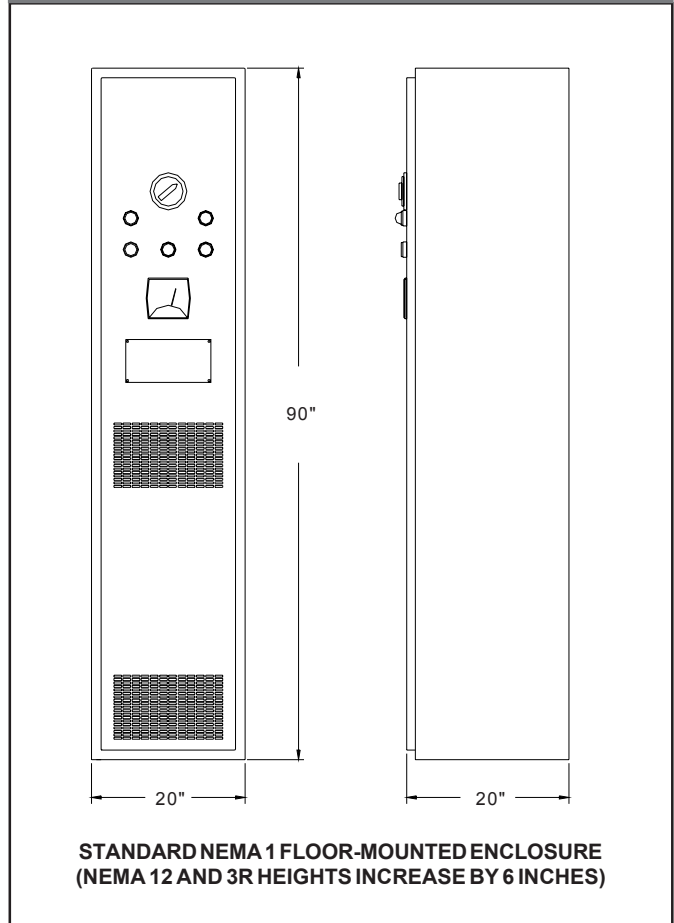

## LOW VOLTAGE WYE SYSTEMS

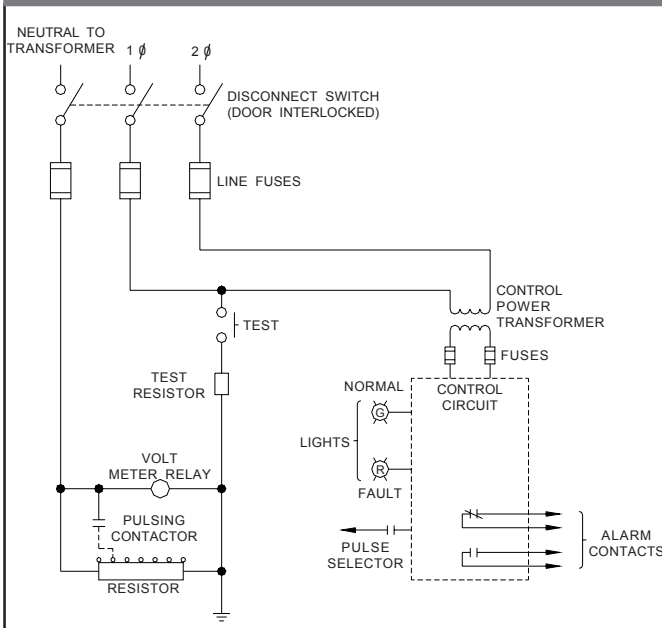

## LOW VOLTAGE DELTA SYSTEMS

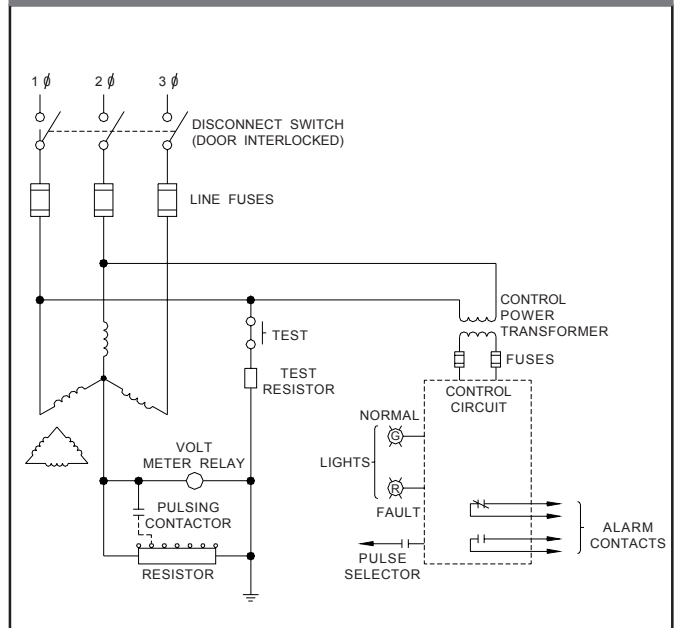

# Type HR Equipment Specifications & Part Numbers

**SPECIFY PART NUMBERS AS FOLLOWS:** HR \_\_\_\_\_

<b>SYSTEM VOLTAGE</b>						
240 volt	1					
480 volt	2					
600 volt	3					
2400 volt	4					
3300 volt	5					
4160 volt	6					
<b>SYSTEM TYPE</b>						
Wye, 50 hertz		W5				
Wye, 60 hertz		W6				
Delta, 50 hertz		D5				
Delta, 60 hertz		D6				
<b>GROUND FAULT CURRENT</b>						
1-6 Amps			A			
2-7 Amps			B			
2-10 Amps			C			
<b>ENCLOSURE STYLE</b>						
Wall-mounted (600V or less)				W		
Floor-mounted				F		
<b>ENCLOSURE TYPE</b>						
NEMA 1					N1	
NEMA 12					N2	
NEMA 3R					N3	
<b>RESISTOR LOCATION</b>						
Remote (for installing in an isolated area)						R
Internal (available for low voltage, floor-mounted units only)						S
Top-mounted (resistors are shipped separately with floor-mounted models)						T

## AVAILABLE OPTIONS

Timing Relay - add "1" to P/N  
 Undervoltage Relay - add "2" to P/N  
 Ammeter with CT - add "3" to P/N  
 Red Warning Beacon - add "4" to P/N  
 Audible Horn with Shutoff - add "5" to P/N  
 Without Pulsing Contactor - add "6" to P/N

For example, the part number for a 2400 volt wye system, 60 Hertz, 2-7A, installed in a wall-mounted, NEMA 1 enclosure with a remote resistor, timing relay, and red warning beacon is HR4W6B-WN1R14.

Ground Fault Detector - A portable clamp-on ammeter w/ case; specify P/N HR5-GFD.

## STANDARD LOW VOLTAGE SPECIFICATION

Qty.	Description (Wye and Delta Systems)
1	Wall-mounted enclosure (an optional floor-mounted enclosure is available).
1	Grounding resistor with multiple taps
1	Disconnect switch interlocked with door.
3	Line fuses
1	Repeat cycle timer (set at 40 pulses per minute)
1	Volt meter relay (2 setpoints)
1	General purpose relay (alarm contacts)
3	Neutral deriving transformer (delta system only)
1	Control power transformer
1	Green indicating light (Normal)
1	Red indicating light (Ground Fault)
1	Selector switch (Normal-Pulse)
2	Pushbutton (Test, Reset)
1	Test resistor
1	Sequence of operation nameplate

Note: Control power obtained from system

## STANDARD MEDIUM VOLTAGE SPECIFICATION

Qty.	Description (Wye and Delta Systems)
1	Floor-mounted enclosure
1	Grounding resistor with multiple taps
1	Isolation switch (fused & door interlocked)
1	Repeat cycle timer (set at 40 pulses per minute)
1	Volt meter relay (2 setpoints)
1	General purpose relay (alarm contacts)
1	Grounding Transformer (3 for delta systems)
1	Control power switch
2	Control power fuses
1	Green pilot light (Normal)
1	Red pilot light (Ground Fault)
1	Selector switch (Normal-Pulse)
2	Pushbutton (Test, Reset)
1	Sequence of operation namplate

Note: 120VAC control power required

**24 HOUR EMERGENCY SERVICE (800) 838-4694**



## *Microcontroller Based Low Voltage Digital High Resistance Grounding System*

Powerohm Digital High Resistance Grounding Systems are an economical means of improving a three-phase ungrounded power system by providing the following advantages:

**System Protection:** Offers protection by providing a ground-to-neutral connection for a three-phase power system, while still allowing to operate as an "ungrounded system." When the neutral of a system is not grounded, the system is vulnerable to potentially damaging ground faults.

**Transient Overvoltage Reduction:** A high resistance grounding system reduces the magnitude of high transient overvoltages appearing during normal switching of a circuit having a ground fault. High transient overvoltages may cause failure of equipment or insulation at locations on the system other than at the point of the fault.

**Ground Fault Detection Warning:** Instantly provides a warning when the first ground fault occurs through an alarm signal. An optional audible horn or red warning beacon is available.

**Ground Fault Location Simplified:** A pulsing contactor allows the ground fault location to be quickly located by use of a portable clamp-on current detector. The ease and swiftness of ground fault location eliminates the need to trace faults by opening and closing secondary feeders, branch circuits and individual loads one at a time.

**Uninterrupted Service:** A single line-to-ground fault left in operation may result in a second ground fault. If a second fault occurs on another phase before the first is removed, considerable damage may be caused by the relatively high line-to-line fault current. The potential for quickly locating and removing faults before damage occurs to critical processes minimizes outages, and costly manufacturing shutdowns.

**Improved Personnel Safety:** Reducing transient overvoltages, equipment arcing, fault levels, insulation failures and fault tracing through circuit isolation schemes decreases hazards to personnel.



## Touch Screen Features

- Large 7" color LCD touch screen
- Simultaneous display on Home screen for neutral ground current, three phase voltage, and neutral voltage.
- On-screen Icons for Quick Start, System Set Points, User Settings, Data Log, Diagnostics, and others for ease of installation and data log/event history retrieval.
- The Quick Start feature guides the user automatically step-by-step through the settings required at start up.
- View data log history in Calendar screen to easily find a specific event.
- View up to one year's history of neutral current/voltage in a graph, allowing for easy visual observation of how the neutral current/voltage has changed throughout the year.
- Diagnostics features include voltage/current calibration, ground fault simulation, and automated capacitive charging current detection.



Figure 1: Home Screen

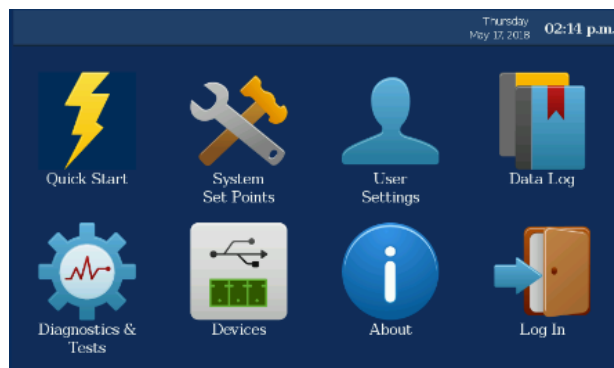

Figure 2: Main Menu

## Standard Features

- User-selectable ground fault detection method: neutral current or line voltage
- Automatic NGR connectivity test
- Microprocessor based logic with real time clock capable of running 7+ years without AC power. The clock is accurate to plus/minus two minutes per year over the full temperature range. Includes low battery indicator.
- The on-board data log memory can store over two years of event history (approx. 112,000 events). The event history can be viewed on screen or by saving it to a USB flash drive. The event history is recorded as a tab delimited file and can be easily opened in Microsoft Excel.
- Multilevel password protection
- On-screen language support for English, Spanish, and French.
- For added safety, a through-door USB port is provided to access data log history without opening the controller door.
- Status LEDs on PCB board inputs/outputs provide visual indication of on/off status.
- System self-test on power up
- Serial communication to PCBs reduces the number of wires for improved reliability
- Audible horn with 12-hour, 24-hour, and 48-hour alarm silence
- Remote alarm contacts for ground fault, low voltage, NGR fault, and control power available

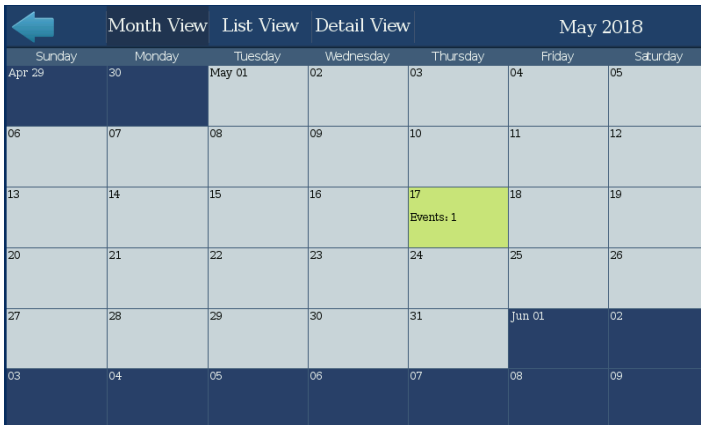

Figure 3: Data Log Calendar View

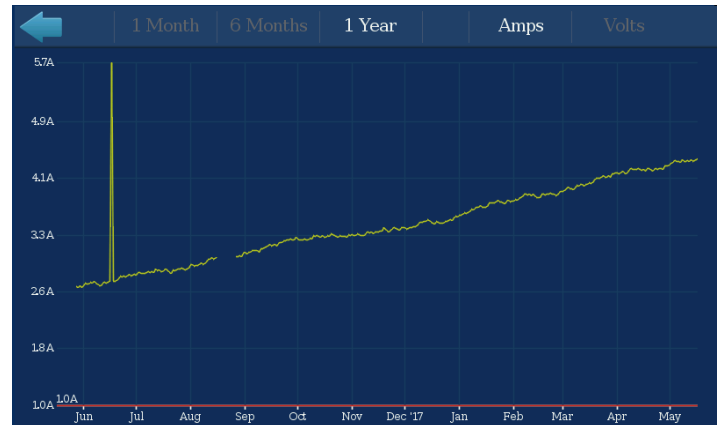

Figure 4: Average Daily Amps/Volts Graph

## Auxiliary Programs

The controller includes as standard ten (10) discrete auxiliary inputs and eight (8) outputs. All auxiliary I/O can be field programmed using the touchscreen and include the ability to add custom messages for on-screen display and data logging. Expandable 12-Channel I/O board for additional I/O.

## Events & Alarms

### Each record tracks:

- Date and time
- Neutral Current
- Neutral Voltage
- Line voltage for all connected phases
- Login state
- State of every alarm
- The state of all aux programs (48 aux programs available)

## Alarm Messages

- Phase A/B/C Ground Fault
- NGR Fault
- Low Current
- Low Voltage
- Low/Missing Clock Battery
- Pulser Fault

## Event Messages

- System Reboot
- User Login
- Logged Out
- Date Changed
- Time Changed
- Pulser Turned ON
- Pulser Turned OFF
- NGR Test Begin
- NGR Test End

Set point changes are recorded in the data log, tracking the previous value and the new value.

## Model Number Designator

	HRG	<u>4</u>	<u>W6</u>	<u>C</u>	<u>F</u>	<u>N1</u>	<u>61</u>	<u>E</u>	<u>1</u>	<u>*</u>
<b>SYSTEM VOLTAGE</b>		↑	↑	↑	↑	↑	↑	↑	↑	↑
	240V	2								
	480V	4								
	600V	6								
<b>SYSTEM TYPE</b>										
	WYE, 50 Hz		W5							
	WYE, 60 Hz		W6							
	DELTA, 50 Hz		D5							
	DELTA, 60 Hz		D6							
<b>GROUND FAULT CURRENT</b>										
	1-5/2-7			A						
	2-5/3-7			B						
	1-7/2-10			C						
	2-7/3-10			D						
	2-10/3-15			E						
<b>ENCLOSURE STYLE</b>										
	WALL MOUNTED (600V OR LESS)				W					
	FLOOR MOUNTED				F					
	SWITCHGEAR				P					
<b>ENCLOSURE TYPE</b>										
	NEMA 1					N1				
	NEMA 3R					N3				
	NEMA 12					N2				
	NEMA 4					N4				
	NEMA 4X					NX				
<b>ENCLOSURE FINISH</b>										
	Painted Ansi-61 Gray					61				
	Painted Tiger Black					TB				
	Stainless Steel 304					S4				
	Stainless Steel 316					S6				
<b>LANGUAGE</b>										
	English							E		
	Spanish							S		
	French							F		
<b>LABELS</b>										
	Printed								1	
	Etched								2	
	Stainless Steel								3	
<b>OPTIONS</b>										*

## Options

- AC – Anti-Condensation Heater
- AH – Edwards Horn
- BS – Bug Screens
- DL – Door Lock
- MB – Modbus over RS485
- ME – Modbus over Ethernet
- P1 – Amber Pulsing Pilot Light
- P2 – White Pulsing Pilot Light
- ST – Shorting Terminal
- UL – UL Rated
- WB – Warning Beacon

Consult factor for other options.

# Type SF Sinewave Output Filters

## APPLICATION

The Powerohm Type SF Sinewave Output Filter is used where variable frequency drives are installed that require extremely long motor leads, such as a submersible downhole pump motor. Since voltage wave reflection is a function of the voltage rise time and the length of the motor leads, there is an impedance mismatch at both ends of the cable. Due to the impedance mismatch, a portion of the waveform high frequency leading edge is reflected back in the direction from which it arrived. When the reflected leading edges encounter other waveform leading edges, their values add, and cause voltage overshoots. As the carrier frequency increases, there are more leading edges present, causing higher and higher voltage overshoots. This condition leads to premature motor failure, halting critical processes involving a downhole pump motor. The Type SF Sinewave Output Filter uses a specially designed RLC network to minimize and nearly eliminate these damaging voltage overshoots.

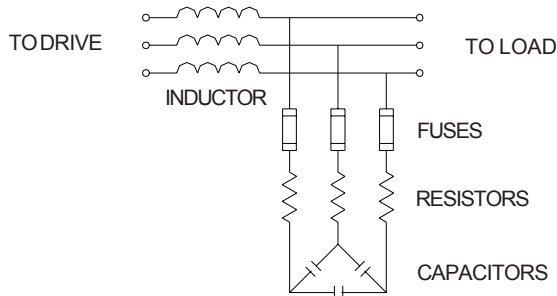

## BASIC CONSTRUCTION

The Type SF Sinewave Filter offers a standard compartmentalized design, with the resistor and inductor in one compartment, and the capacitors and other control components, such as cooling fans, relays, fuses and indicator lights in another. This compartmentalized design isolates the heat sensitive capacitors and control components from the heat generating resistor and inductor. There are slotted openings in the enclosure bottom to allow air to enter the enclosure. The cooling fans are mounted on the vertical barrier, which creates the two compartments. The fans pull air across the capacitors and control components, and push the air across the resistor and inductor. The air is then exhausted through openings in the resistor/inductor compartment. Each unit has special fuses with a N.O. and N.C. contact which allows monitoring of a blown fuse condition. If a fuse opens, a red indicator located on the exterior of the enclosure will light. An additional control relay provides N.O. and N.C. contacts for remote monitoring of the filter status, or allows for shutdown of the variable frequency drive.

Units are available in either a NEMA 1 or NEMA 3R enclosure. The Nema 3R outdoor model includes a baffling plate behind the louvers to prevent water from coming in contact with the resistor or inductor during extreme storm conditions. Finish options are power coated, mill galvanized, hot dipped galvanized, or stainless steel.

INDUCTOR & RESISTOR COMPARTMENT



CAPACITOR & CONTROLS COMPARTMENT



## DESIGN REQUIREMENTS

The following information is necessary to facilitate a proper Type SF Sinewave Output Filter design:

- Normal Line Voltage
- Carrier Frequency
- Current Rating
- Motor Horsepower
- Fundamental Frequency
- Enclosure Type

# Harmonic Filter Applications

## APPLICATION

Harmonic filters are commonly used in industrial applications where there are concerns about harmonic distortion caused by the increasing number of nonlinear power electronic devices. Harmonic distortion causes stress and resultant problems for a plant's distribution system, as well as all of the equipment that is serviced by that system. For example, the higher voltage peaks that are created by harmonic distortion put extra stress on motor and wire insulation, which ultimately results in insulation breakdown and failure. In addition, harmonics increase RMS current, causing increased operating temperatures for many pieces of equipment, resulting in greatly reduced equipment life. The primary objective of a harmonic filter is to reduce the amplitude of one or more fixed frequency currents or voltages.

Powerohm can design resistor configurations for harmonic filtering systems requiring power resistors, such as static var compensation systems and damping filters. The resistor is normally designed to meet certain criteria outlined in a detailed specification. Our experienced engineering staff, using our wide selection of resistor elements, will design a resistor assembly to meet your needs.

## BASIC CONSTRUCTION

The resistor type is determined largely by the requirements of the specification. Elements are selected to best meet the power rating, inductance limits and voltage requirements of the system. A typical assembly includes all stainless steel elements, interconnecting jumpers, and terminals. Most designs are natural convection cooled, but forced air cooling can be utilized for certain applications.

Powerohm filter resistors are available in open-style configurations for indoor or outdoor use. These resistors can be installed in NEMA 1 or NEMA 3R enclosures, complete with nearly any finish including mill galvanized, power coated, hot dipped galvanized after fabrication, aluminum or stainless steel. Our assemblies are also available with additional options such as special entrance bushings, elevating stands, and drip hoods for open-style units.



**Pictured above is a 3-phase Powerohm resistor configuration rated 150 kW continuous, for a 5th and 7th harmonic filter. The harmonic filter is rated 3000 KVAR for a 13.8 kV system. The unit is installed outdoors in Milne Point, Alaska, approximately one mile from the Arctic Ocean, where it is subjected to wind blown snow and ambient temperatures as low -130°F.**

## DESIGN REQUIREMENTS

The following information is necessary to facilitate a proper resistor design:

- Resistance with Tolerances
- Current Rating or Spectrum
- Inrush Peaks and Duty
- Voltage Class
- Inductance Limits
- Enclosure Requirements



## TYPE LG BRAKING MODULES

AC variable frequency drives are commonly used with general purpose AC induction motors to form reliable variable speed drive systems. Problems with these drive systems can occur when an application requires a deceleration rate faster than what can be managed by the drive alone, or when motor speeds exceed the synchronous speed set by the output frequency of the drive (which is called an overhauling load condition). Both of these conditions create regenerated power which flows from the motor back into the drive, causing its DC Bus Voltage to rise. To manage the regenerated power and avoid shutting the drive down due to an over-voltage trip, this power must be dissipated by an external braking resistor. Braking Modules are used in conjunction with an AC drive to monitor the DC bus of the drive and activate external braking resistor as needed.

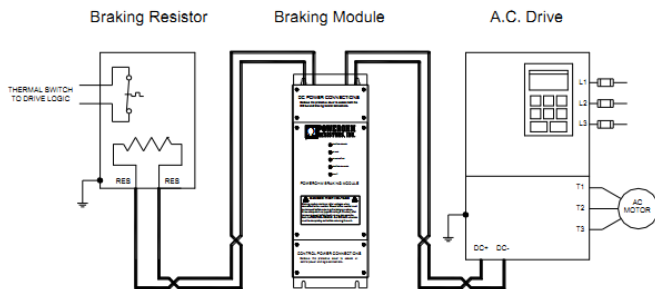

A typical AC Drive, Braking Module and Braking Resistors shown in the left diagram.

## PRODUCT OVERVIEW

- Nominal Voltage Ratings of 240, 480 and 600 volts (208 to 720VAC available).
- Continuous Current Ratings up to 1200 amps.
- Peak Current Ratings as high as 1800 amps.
- Common Mode Noise Filtration.
- Electronic Short Circuit Protection.
- Instantaneous Bus Over and Under Voltage Detection.
- Heat Sink Over-temperature Protection.
- Communication Modules such as Ethernet, Profibus and Mod Bus. Others are available.
- Master/ Slave Configuration (shown below with Fiber Optic Communication).

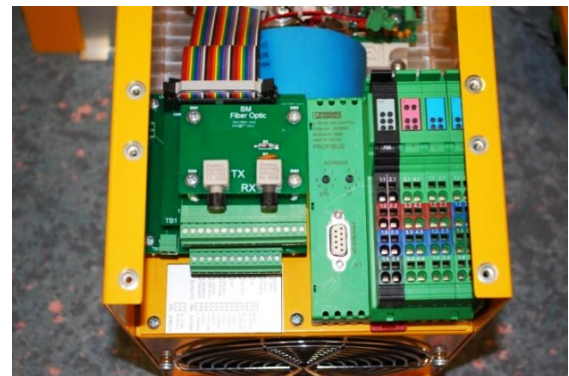



## THE POWEROHM ADVANTAGE

- Programmable Voltages.
- Highest Continuous and Peak Amps in Class.
- Highest Voltage Trip Points in Class.
- No Separate DC Bus Pre-Charge Module Required

## ELECTRICAL RATINGS AND DIMENSIONS – 450 AMP AND 600 AMP

Part Number	Line Voltage	Turn On Voltage	Cont Current	Peak Current	Min Ohms
BM208-450	208	336	450	600	0.56
BM240-450	240	390	450	600	0.65
BM380-450	380	612	450	600	1.02
BM415-450	415	670	450	600	1.12
BM480-450	480	775	450	600	1.29
BM600-450	600	970	450	600	1.62
BM690-450	690	1090	450	600	1.82
BM720-450	720	1120	450	600	1.87

Part Number	Line Voltage	Turn On Voltage	Cont Current	Peak Current	Min Ohms
BM208-600	208	336	600	900	0.37
BM240-600	240	390	600	900	0.43
BM380-600	380	612	600	900	0.68
BM415-600	415	670	600	900	0.74
BM480-600	480	775	600	900	0.86
BM600-600	600	970	600	900	1.08
BM690-600	690	1090	600	900	1.21
BM720-450	720	1120	600	900	1.24

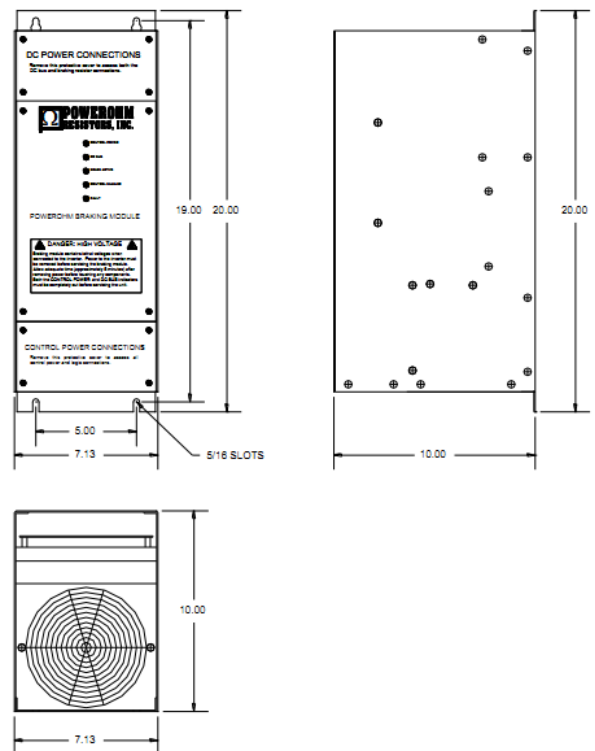



## TYPE LG BRAKING MODULES

AC variable frequency drives are commonly used with general purpose AC induction motors to form reliable variable speed drive systems. Problems with these drive systems can occur when an application requires a deceleration rate faster than what can be managed by the drive alone, or when motor speeds exceed the synchronous speed set by the output frequency of the drive (which is called an overhauling load condition). Both of these conditions create regenerated power which flows from the motor back into the drive, causing its DC Bus to rise. To manage the regenerated power and avoid shutting the drive down due to an over-voltage trip, this power must be dissipated by an external braking resistor. Braking Modules are used in conjunction with an AC drive to monitor the DC bus of the drive and activate external braking resistor as needed.

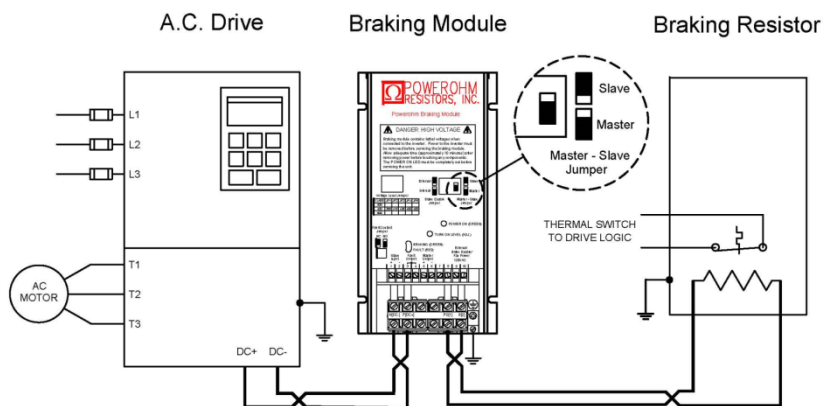

A typical AC Drive, Braking Module and Braking Resistor configuration.

## PRODUCT OVERVIEW

- Nominal Voltage Ratings of 240, 480 and 600 volts.
- Continuous Current Ratings up to 115 amps.
- Peak Current Ratings as high as 300 amps.
- Optional Enable Control Voltages of 120VAC or 24VDC.
- Compact Frame with High Current Capacity.
- Heat sink Over-temperature Protection.
- Under Voltage Detection for Logic Supply.
- Master/ Slave Configuration.
- External or Internal Brake Enable Capability.

## ELECTRICAL SPECIFICATIONS AND PART DIMENSIONS

Powerohm Part Number	Nominal AC Line Voltage	RMS Continuous Current	Turn ON Voltage	Max Peak Current
BM2-50	240	50	390	200
BM2-115	240	115	390	200
BM2-150	240	150	390	300
BM4-50	480	50	775	200
BM4-115	480	115	775	200
BM4-150	480	150	775	300
BM6-50	600	50	970	200
BM6-115	600	115	970	200
BM6-150	600	150	970	300

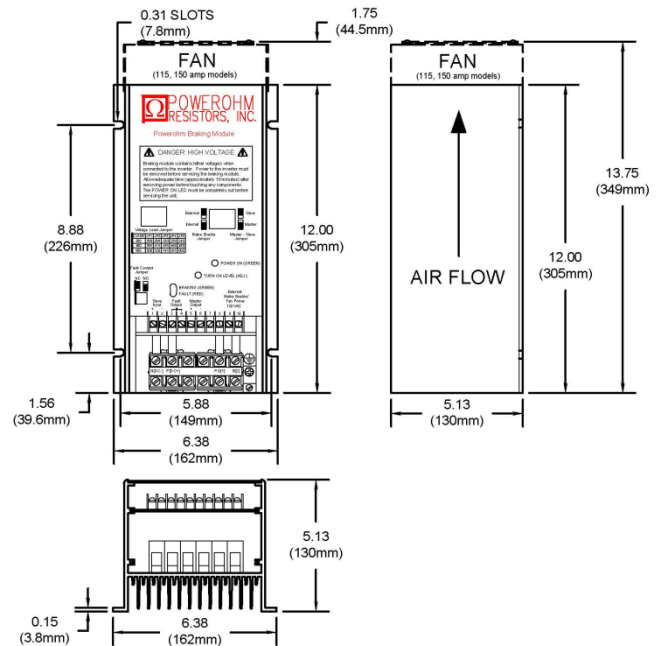

**Note:** Peak currents up to the maximum are allowed at intermittent duty cycles, as long as:

- The Module RMS Load Current rating is not exceeded.
- RMS Load Current = Peak Current X the square root of duty cycle.

\* The cooling fan option is necessary to achieve the 115 amp rating and requires 120VAC, or optional 24VDC Control Power for fan.

## ENVIRONMENTAL RATINGS

<b>Ambient Temperature:</b>	-10°C to 40°C
<b>Maximum Altitude:</b>	3300 feet (1000m)
<b>Maximum Vibration:</b>	10 to 20Hz, 32ft/sec/sec; 20 to 50Hz, 6.5 ft/sec/sec

## WEIGHTS

BM50 Amp Series without fan:	9 lbs.
BM115, BM150 Amp Series with fan:	11 lbs.

For detailed specifications and mounting instructions, download the Type LG Installation Manual on the web at [www.powerohm.com](http://www.powerohm.com).





**POWEROHM  
RESISTORS, INC.**



**Forced Air  
Braking Resistors  
for the Oil & Gas  
Industries**



# When Choosing a Forced Air Resistor for Your Powerohm Resistors In

**Powerohm is the perfect choice for ruggedly designed units to withstand the rigors of Land or Sea.**

Our space saving designs feature multiple enclosure offerings, including a large array of Horizontal and Vertical configurations that are engineered to provide the dependability needed to maintain your production levels 24/7.

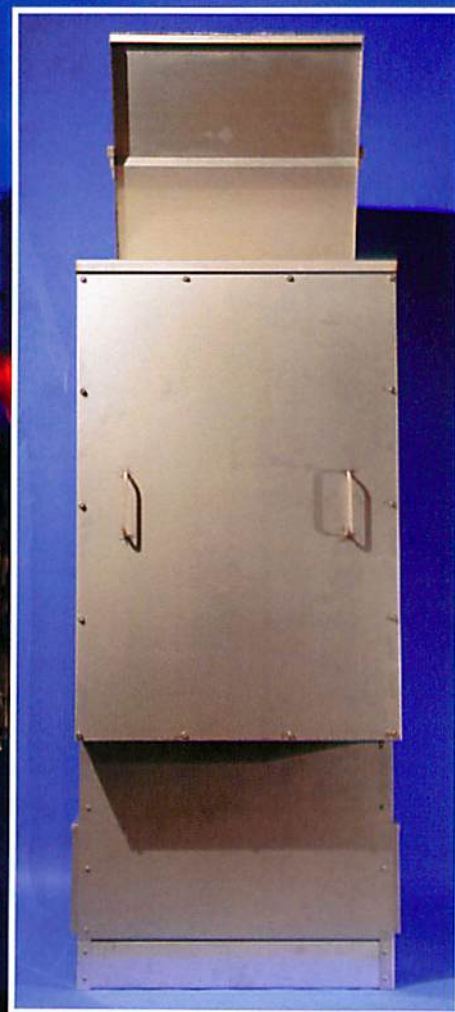

*From the extremes of the tundra of the northern and southern hemispheres to the tropics, Powerohm is the answer for all your Dynamic Braking Resistor needs.*



# Our Top Drive or Draw Works Applications c. Sets the Standards

Powerohm's unique "Air-Cooled Resistor" design allows for maximum element mass in the smallest frame package. The wide current path of the stainless steel element reduces the need for parallel connections. It also provides the highest efficient watt density and watt second ratios, when compared against other element styles such as round wire or mesh style forms.

Our forced air-cooled units which range from 600 KW to 2.4 MW, feature a high performance blower assembly that provides a relatively low noise solution as well as a powerful air flow. Our custom design features only the highest quality components combined with an all welded rigid frame to insure maximum production uptime.

Powerohm's braking resistor designs are perfectly matched for your specification and the Brake Module characteristics, providing the maximum torque needed for energy dissipation from the braking cycles encountered in Top Drive, Draw Works and Pump Jack applications.

## Standard Packages Include:

- Rugged Enclosures available in Galvanized Steel, Stainless Steel or Powder Coat Finishes
- Stainless Steel Non-Breakable Resistor Elements
- Outdoor Front and Rear Exhaust Guards (Horizontal)
- Removable Outdoor Exhaust Hood (Vertical)
- Heavy Duty Resistor Terminations
- Air Intake Louvers with Removable Filter Screens

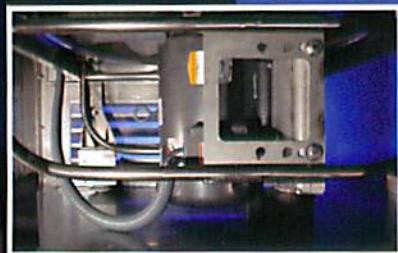
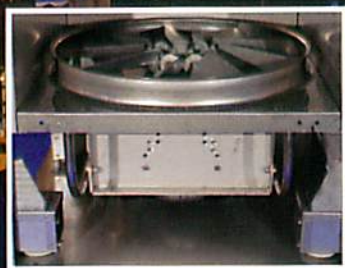

- Sealed Compartment for Resistor, Fan and Safety Circuit Connections
- Heavy Duty Blower with a Quick "Change Out" Bracket System
- Pressure Differential Switch Protection to Monitor Air Flow
- Exhaust Temperature Switches for Element Protection
- Lifting Eyes, Feet and/or Forklift Channels





## Horizontal Unit

### Standard Forced Air Cooled Enclosure Sizes

Power Rating (Kilowatts)	Overall Dimensions (Inches)			
	A	B	C	D
300	36	36	72	80
450	36	36	72	80
600	42	48	72	84
900	42	48	84	96
1200	42	48	96	108
2400	42	82	96	108

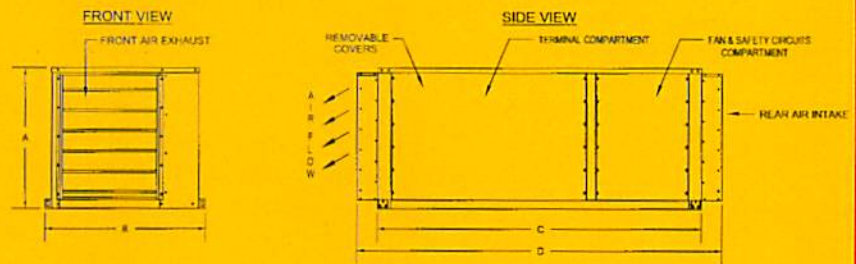

## Vertical Unit

### Standard Forced Air Cooled Enclosure Sizes

Power Rating (Kilowatts)	Overall Dimensions (Inches)			
	A	B	C	D
300	88	68	36	42
450	100	80	36	42
600	88	68	42	52
900	110	80	42	52
1200	122	92	42	52

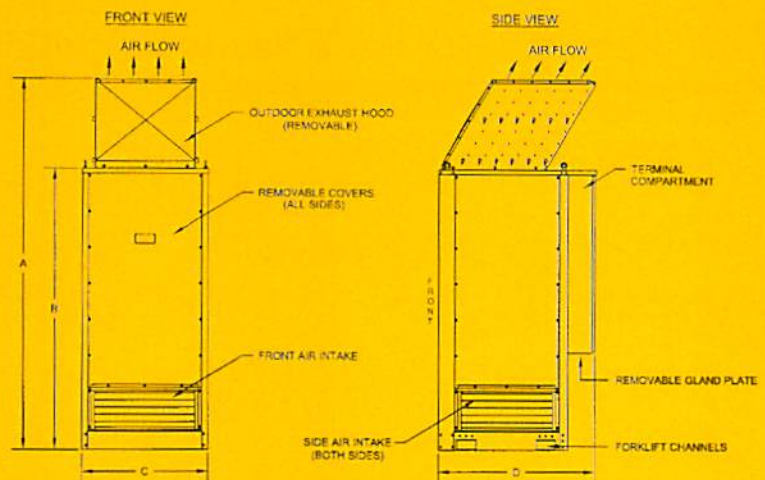

**Sales & Service:** 125 W. 34th Street • Covington, Kentucky 41015

**Toll Free:** 800.838.4694 • **Local:** 859.384.8088 • **Fax:** 859.384.8099

**Manufacturing:** 5713 13th Street • Katy, Texas 77493 • **Local:** 281.391.6800

[www.powerohm.com](http://www.powerohm.com)



## **POWEROHM TRANSIT RESISTORS**

Braking resistors suitable for transit applications must sustain severe operating conditions. Typical environments include frequent exposure to rain, snow and ice with track conditions that create persistent dust and debris associated with everyday travel. Resistors must be designed to withstand considerable mechanical shock and vibration, but include design features that limit excessive weight and space. Units must be designed to endure the above criteria and also meet the electrical and thermal cycling parameters of our customer's specification.



Powerohm engineers are experienced and qualified to design your transit products. We have accumulated over 100 years of combined experience working on specialized resistor applications. Our knowledgeable staff will design a final product that will offer components and materials that are tolerant of the most severe transit environments. From our two locations in Houston, Texas and Covington, Kentucky we will bring you a final package and price that will compete with any market or entity available worldwide.

## **OEM REPLACEMENTS**

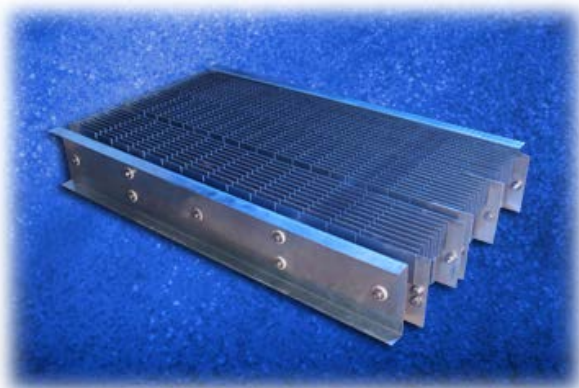

Our large selection of resistor alloys, element styles and insulating media allow us to offer units that incorporate maximum reliability along with minimum overall weights and sizes. Powerohm offers custom coil, grid and ribbon assemblies specifically designed for use in transit applications such as light rail, trolley systems, electric buses, locomotive and heavy railways.

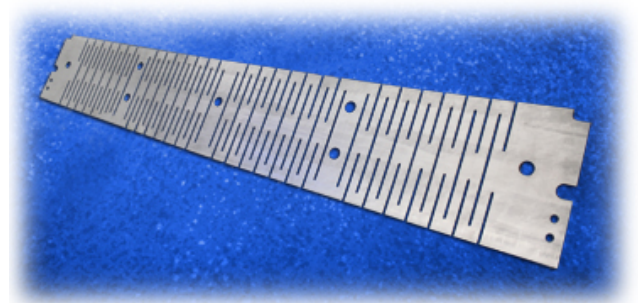

Based on our engineering experience, technical excellence and quality resistor designs, coupled with our ISO 9001:2000 Quality Management System (includes both the design and manufacture), we believe we are the world's best solution for quality transit resistor products.

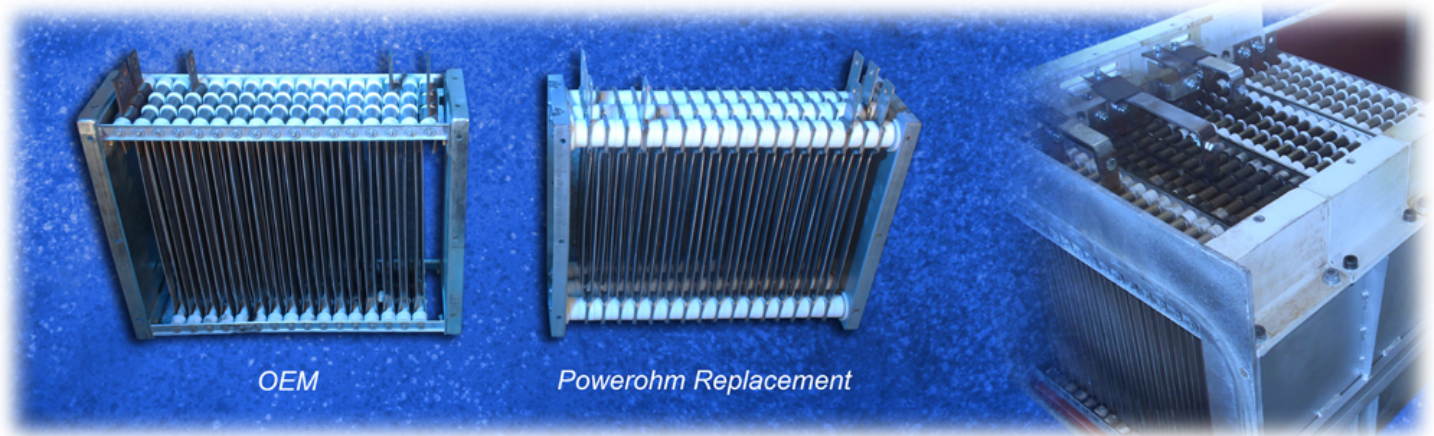

OEM

Powerohm Replacement

## OEM REPLACEMENTS FOR ELECTRIC BUSES



Powerohm offers replacements for roof mounted braking resistors on buses, utilizing punched grid elements for superior cooling over the round edgewound elements furnished by the O.E.M. The flat surface of the grid element allows air to flow over a larger surface area, more effectively cooling the element, reducing fatigue and increasing longevity.

## CONTACT INFORMATION

Powerohm Resistors Inc.  
1-800-838-4694 x 1 – Sales  
[sales@powerohm.com](mailto:sales@powerohm.com) - Email

Whether a bid for a new application or an economical replacement for an existing O.E.M., contact the most experienced engineering staff in the power resistor industry.

