



COMMUNICATION EQUIPMENT PROTECTION: TRISIL™

FEATURES

- BIDIRECTIONAL CROWBAR PROTECTION
- VOLTAGE RANGE : FROM 8V to 270V
- REPETITIVE PEAK PULSE CURRENT:
I_{PP} = 100 A (10/1000µs)
- HOLDING CURRENT: I_H = 150mA or 225mA
- LOW LEAKAGE CURRENT: I_R = 2 µA max

DESCRIPTION

The SMP100 series are transient surge arrestors used for the protection of sensitive tele-com equipment.

MAIN APPLICATIONS

Any sensitive equipment requiring protection against lightning strikes :

- ANALOG AND DIGITAL LINE CARDS
- MAIN DISTRIBUTION FRAMES
- TERMINALS AND TRANSMISSION EQUIPMENT
- GAS-TUBE REPLACEMENT

BENEFITS

- NO AGEING AND NO NOISE
- IF DESTROYED, THE SMP100 FALLS INTO SHORT CIRCUIT, STILL ENSURING PROTECTION
- BOARD SPACE SAVING

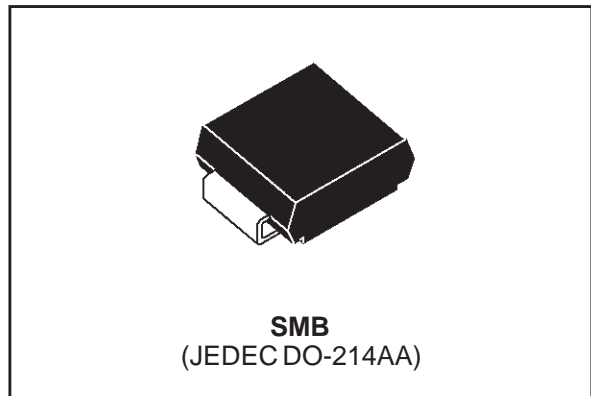

SCHEMATIC DIAGRAM

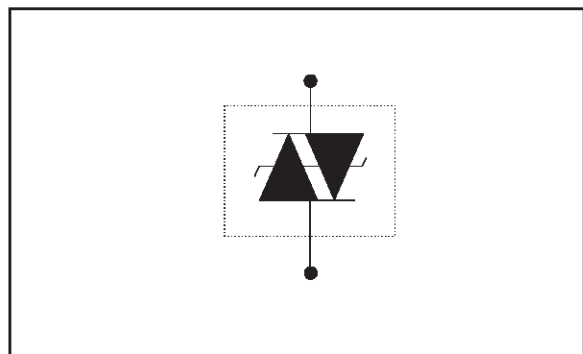

COMPLIES WITH THE FOLLOWING STANDARDS:	Peak Surge Voltage (V)	Voltage Waveform (µs)	Current Waveform (µs)	Admissible I_{pp} (A)	Necessary Resistor (Ω)
ITU K20	4000	10/700	5/310	100	-
VDE0433	4000	10/700	5/310	100	-
VDE0878	4000	1.2/50	1/20	100	-
IEC-1000-4-5	level 4 level 4	10/700 1.2/50	5/310 8/20	100 100	- -
FCC Part 68, lightning surge type A	1500 800	10/160 10/560	10/160 10/560	200 100	- -
FCC Part 68, lightning surge type B	100	9/720	5/320	25	-
BELLCORE TR-NWT-001089 First level	2500 1000	2/10 10/1000	2/10 10/1000	500 100	- -
BELLCORE TR-NWT-001089 Second level	5000	2/10	2/10	500	-
CNET I31-24	4000	0.5/700	0.8/310	100	-

SMP100-xxx

THERMAL RESISTANCES

Symbol	Parameter	Value	Unit
$R_{th(j-l)}$	Junction to leads	20	°C/W
$R_{th(j-a)}$	Junction to ambient on printed circuit (with standard footprint dimensions)	100	°C/W

ABSOLUTE MAXIMUM RATINGS ($T_{amb} = 25^{\circ}\text{C}$)

Symbol	Parameter	Value	Unit
I_{pp}	Peak pulse current: 10/1000 μs (open circuit voltage waveform 1 kV 10/1000 μs)	100	A
	5/310 μs (open circuit voltage waveform 4 kV, 10/700 μs)	150	A
	8/20 μs (open circuit voltage waveform 4 kV 1.2/50 μs)	250	A
	2/10 μs (open circuit voltage waveform 2.5kV 2/10 μs)	500	A
I_{FS}	Fail-safe mode	8/20 μs	5 kA
I_{TSM}	Non repetitive surge peak on-state current One cycle	50Hz 60Hz	55 60 A A
	Non repetitive surge peak on-state current F = 50Hz	0.2s 2s	25 12 A A
T_L	Maximum lead temperature for soldering during 10s	260	°C
T_{stg} T_j	Storage temperature range Maximum junction temperature	- 55 to + 150 150	°C °C

Note 1: Pulse waveform

10 / 1000 μs	$t_r = 10 \mu\text{s}$	$t_p = 1000 \mu\text{s}$
8 / 20 μs	$t_r = 8 \mu\text{s}$	$t_p = 20 \mu\text{s}$
5 / 310 μs	$t_r = 5 \mu\text{s}$	$t_p = 310 \mu\text{s}$
1 / 20 μs	$t_r = 1 \mu\text{s}$	$t_p = 20 \mu\text{s}$
2 / 10 μs	$t_r = 2 \mu\text{s}$	$t_p = 10 \mu\text{s}$

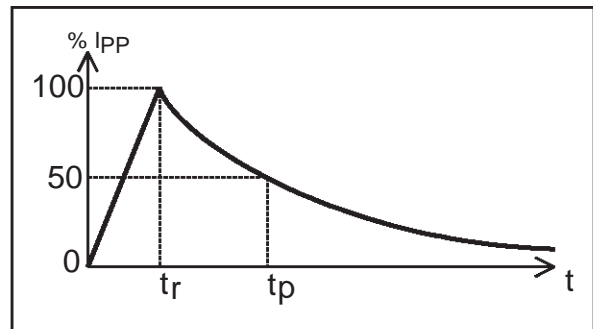

ELECTRICAL CHARACTERISTICS ($T_{amb} = 25^{\circ}\text{C}$)

Symbol	Parameter
V_{RM}	Stand-off voltage
I_{RM}	Leakage current at stand-off voltage
V_R	Continuous reverse voltage
I_R	Continuous reverse current
V_{BR}	Breakdown voltage
V_{BO}	Breakover voltage
I_H	Holding current
I_{BO}	Breakover current
I_{PP}	Peak pulse current
C	Capacitance

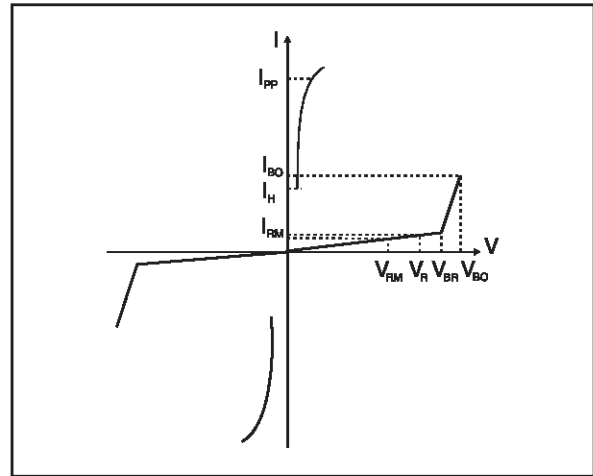
**STATIC PARAMETERS**

Type	$I_{RM} @ V_{RM}$ max.		$I_R @ V_R$ max. note 1		$V_{BO} @ I_{BO}$ max. note 2		I_H min. note 3	C typ. note 4
	μA	V	μA	V	V	mA	mA	pF
SMP100-8	2	6	50	8	20	800	50(typ)	100
SMP100LC-35	2	32	50	35	55	800	150	90
SMP100-65	2	55	50	65	80	800	150	160
SMP100-120	2	110	50	120	160	800	150	140
SMP100-140	2	120	50	140	200	800	150	140
SMP100-200	2	170	50	200	265	800	150	130
SMP100-230	2	200	50	230	300	800	150	120
SMP100-270	2	230	50	270	350	800	150	120
SMP100-140H225	2	120	50	140	200	800	225	140
SMP100-200H225	2	170	50	200	265	800	225	130
SMP100-230H225	2	200	50	230	300	800	225	130
SMP100-270H225	2	230	50	270	350	800	225	120

Note 1 : I_R measured at V_R guarantees $V_{BR} > V_R$

Note 2 : Measured at 50Hz, see test circuit 1. In any case $V_{BOmin} \geq V_{BR}$

Note 3 : See functional holding current test circuit 2.

Note 4 : $V_R=1\text{V}$ bias, $V_{RMS}=1\text{V}$, $F=1\text{MHz}$.

DYNAMIC PARAMETERS

Symbol	Test conditions (see note 5)	Type	Max.	Unit
V_{BO}	<p>Test conditions 1 $dV/dt = 100 \text{ V}/\mu\text{s}$, $di/dt < 10 \text{ A}/\mu\text{s}$, $I_{PP} = 100 \text{ A}$</p> <p>Test conditions 2 $dV/dt = 1 \text{ kV}/\mu\text{s}$, $di/dt < 10 \text{ A}/\mu\text{s}$, $I_{PP} = 10 \text{ A}$</p>	SMP100-8	25	V
		SMP100LC-35	55	
		SMP100-65	95	
		SMP100-120	200	
		SMP100-140	220	
		SMP100-200	285	
		SMP100-230	320	
		SMP100-270	370	
		SMP100-140H225	220	
		SMP100-200H225	285	
		SMP100-230H225	320	
		SMP100-270H225	370	

Note 5 : V_{BO} parameters are given by a KeyTek 'System 2' generator with PN246I module.
 See test circuits 3 for V_{BO} dynamic parameters.

TEST CIRCUIT 1 FOR I_{BO} and V_{BO} parameters :

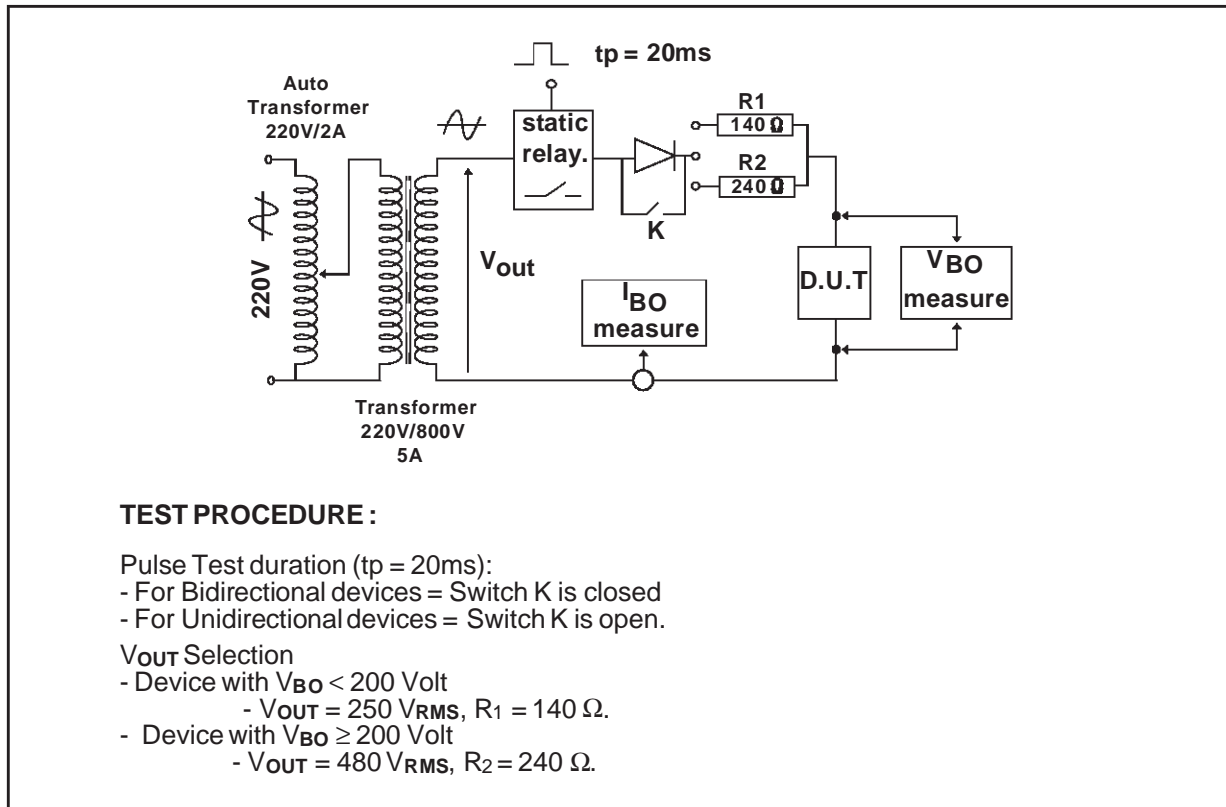

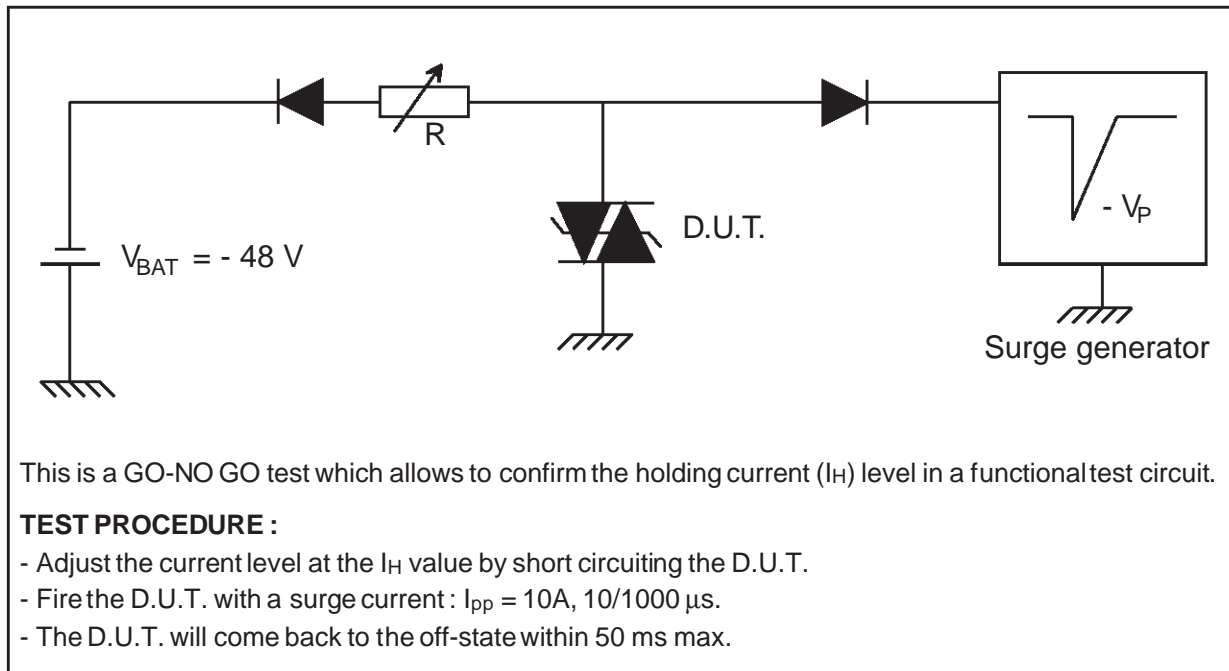
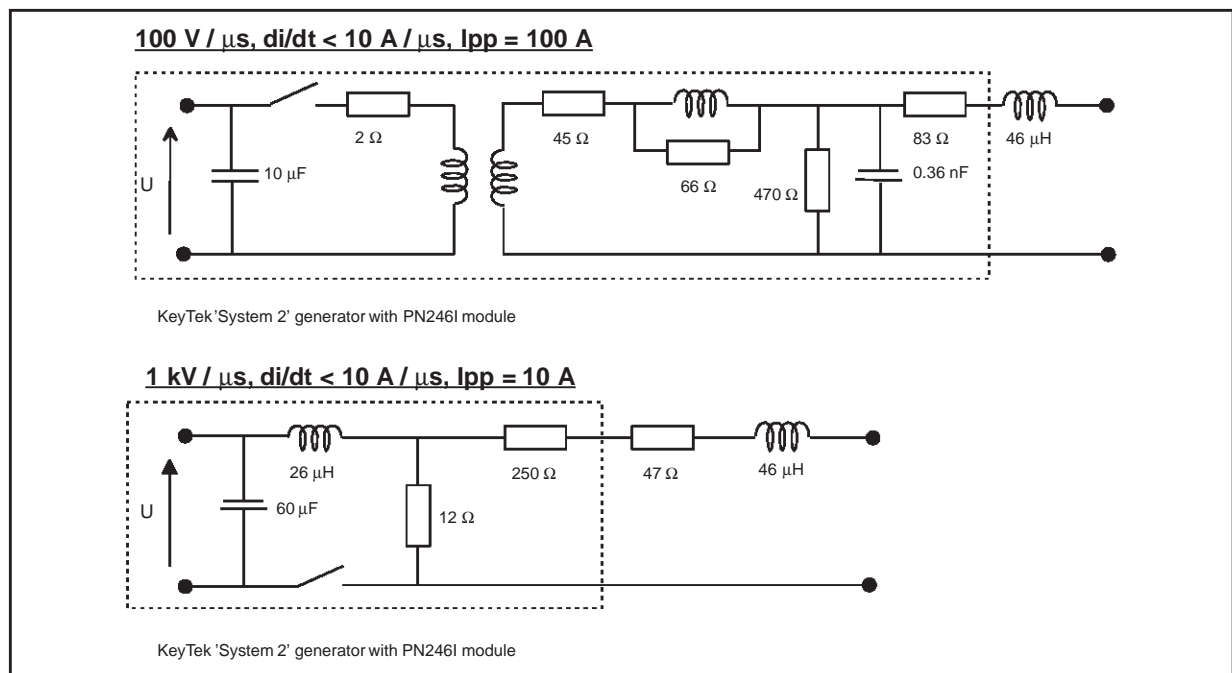
TEST CIRCUIT 2 for I_H parameter.**TEST CIRCUITS 3 FOR V_{BO} DYNAMIC PARAMETERS**

TYPICAL APPLICATIONS

1 - Primary protection module

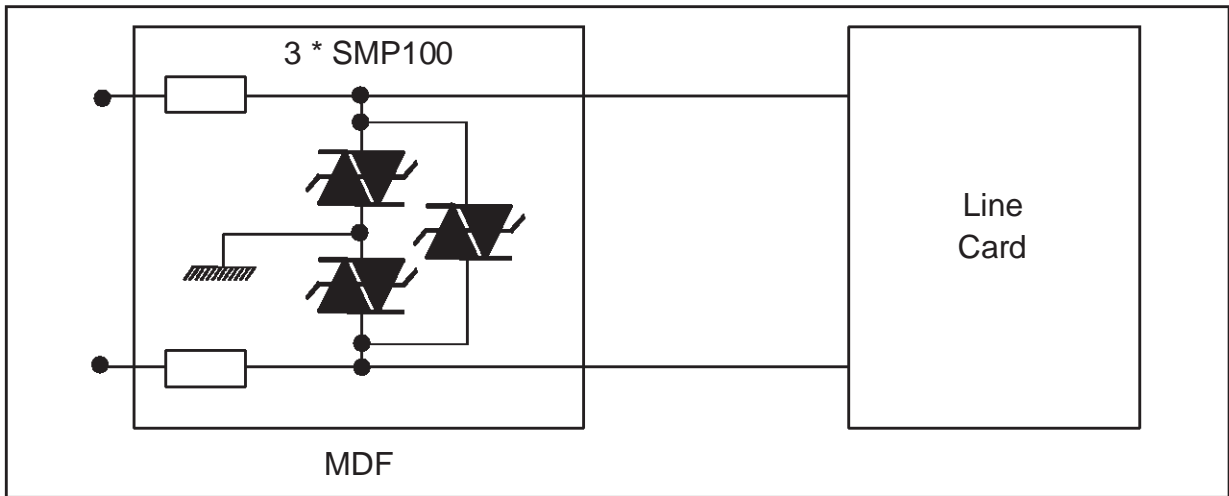

2 - Line card protection

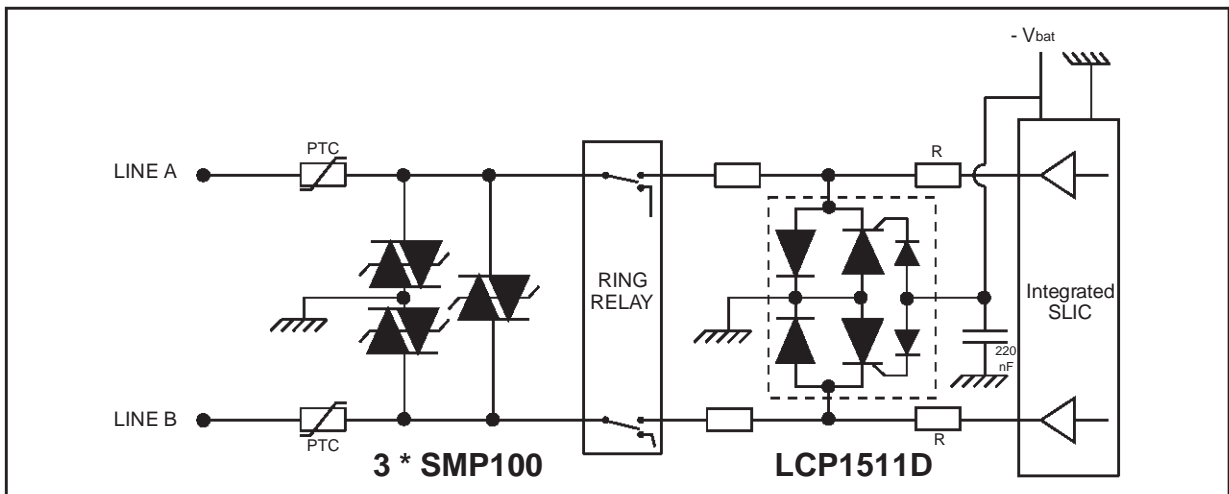

3 - ISDN: U interface protection

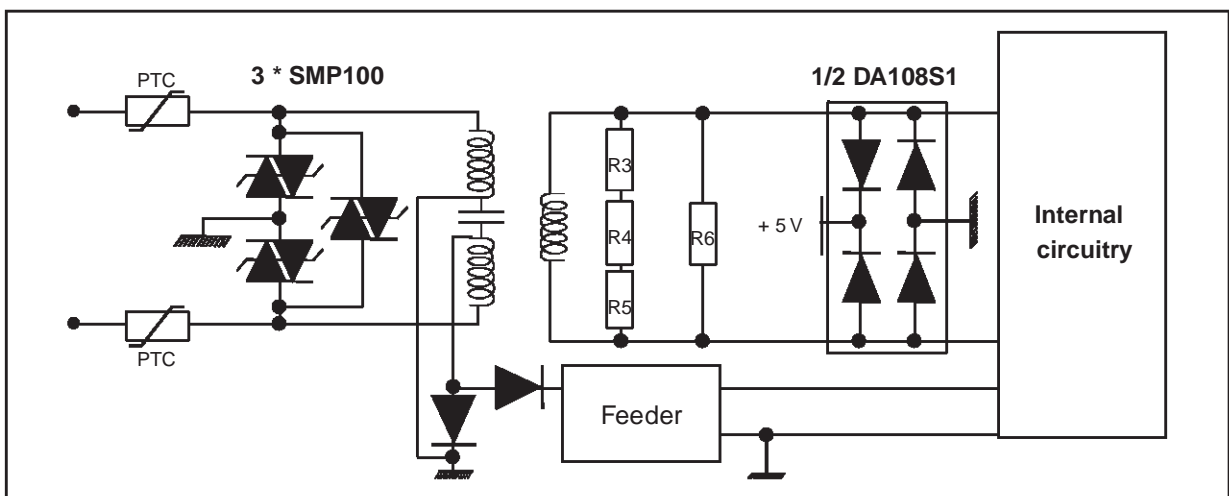

Fig 1 : Non repetitive surge peak on-state current versus overload duration (T_j initial = 25 °C).

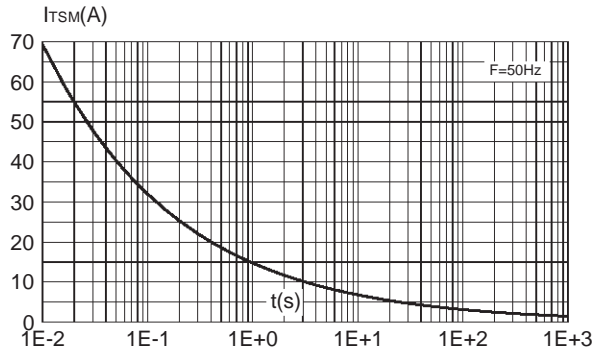

Fig 2 : On-state voltage versus on-state current (typical values).

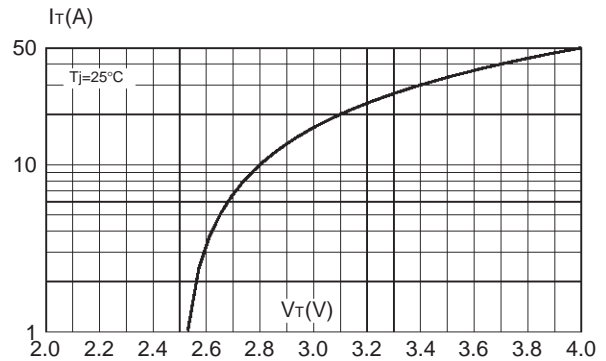

Fig 3 : Relative variation of holding current versus junction temperature.

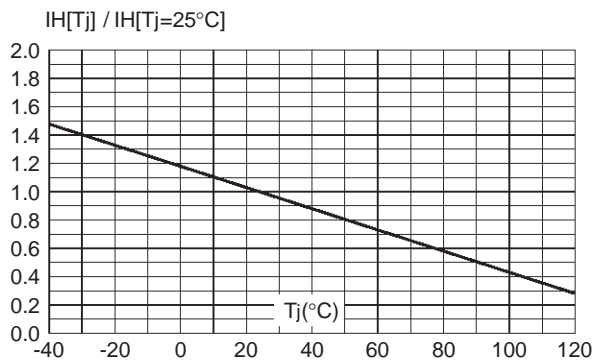

Fig 4 : Variation of thermal impedance junction to ambient versus pulse duration.

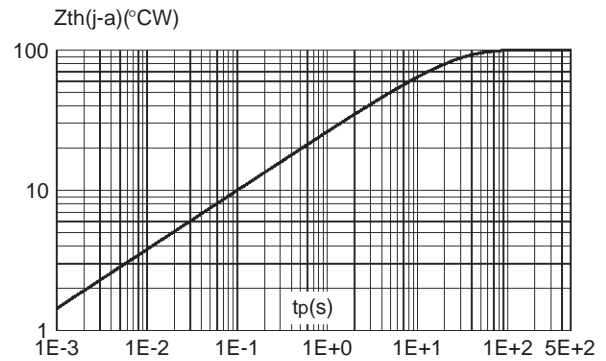
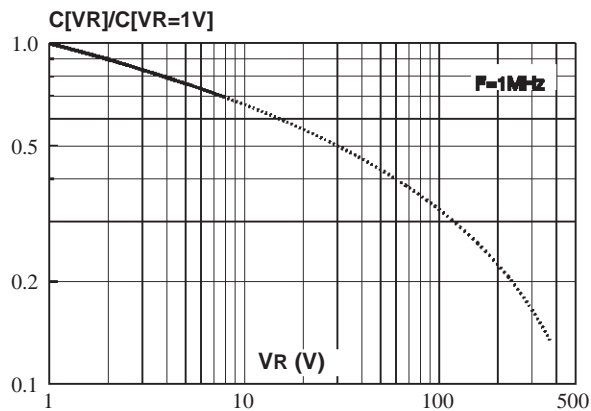

Fig 5 : Relative variation of junction capacitance versus reverse voltage applied (typical values).

Note : For other types than SMP100-8, the curve can be extrapolated (dotted line)



SMP100-xxx

MARKING

Type	Marking	Package	Weight	Base qty	Delivery mode
SMP100-8	PL8	SMB	0.107g	2500	Tape & Reel
SMP100LC-35	L35	SMB	0.107g	2500	Tape & Reel
SMP100-65	P06	SMB	0.107g	2500	Tape & Reel
SMP100-120	P12	SMB	0.107g	2500	Tape & Reel
SMP100-140	P14	SMB	0.107g	2500	Tape & Reel
SMP100-200	P20	SMB	0.107g	2500	Tape & Reel
SMP100-230	P23	SMB	0.107g	2500	Tape & Reel
SMP100-270	P27	SMB	0.107g	2500	Tape & Reel
SMP100-140H125	P16	SMB	0.107g	2500	Tape & Reel
SMP100-200H225	P22	SMB	0.107g	2500	Tape & Reel
SMP100-230H225	P24	SMB	0.107g	2500	Tape & Reel
SMP100-270H225	P29	SMB	0.107g	2500	Tape & Reel

■ Epoxy meets UL94, V0

ORDER CODE

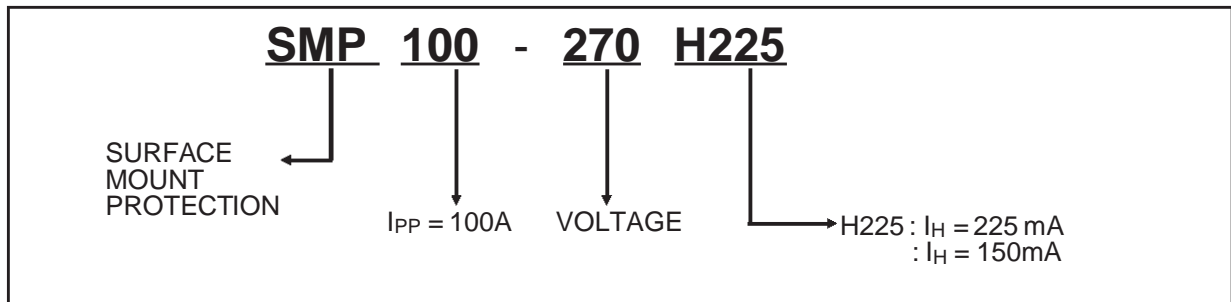

PACKAGE MECHANICAL DATA

SMB (Plastic)

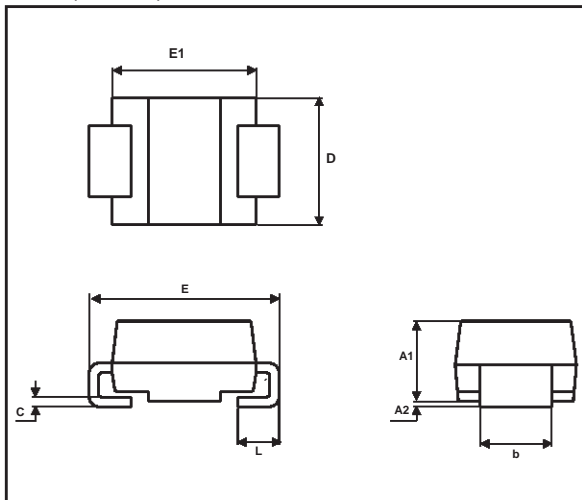

REF.	DIMENSIONS			
	Millimeters		Inches	
	Min.	Max.	Min.	Max.
A1	1.90	2.45	0.075	0.096
A2	0.05	0.20	0.002	0.008
b	1.95	2.20	0.077	0.087
c	0.15	0.41	0.006	0.016
E	5.10	5.60	0.201	0.220
E1	4.05	4.60	0.159	0.181
D	3.30	3.95	0.130	0.156
L	0.75	1.60	0.030	0.063

FOOT PRINT (in millimeters)

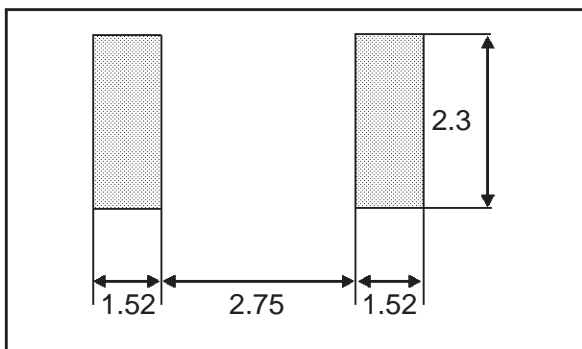

Information furnished is believed to be accurate and reliable. However, STMicroelectronics assumes no responsibility for the consequences of use of such information nor for any infringement of patents or other rights of third parties which may result from its use. No license is granted by implication or otherwise under any patent or patent rights of STMicroelectronics. Specifications mentioned in this publication are subject to change without notice. This publication supersedes and replaces all information previously supplied. STMicroelectronics products are not authorized for use as critical components in life support devices or systems without express written approval of STMicroelectronics.

The ST logo is a registered trademark of STMicroelectronics

© 1999 STMicroelectronics - Printed in Italy - All rights reserved.

STMicroelectronics GROUP OF COMPANIES

Australia - Brazil - China - Finland - France - Germany - Hong Kong - India - Italy - Japan - Malaysia
Malta - Morocco - Singapore - Spain - Sweden - Switzerland - United Kingdom - U.S.A.

<http://www.st.com>

This datasheet has been downloaded from:

www.DatasheetCatalog.com

Datasheets for electronic components.