

5. ASSEMBLE SLEEVE RETAINER AS SHOWN. SNAP SLEEVE RETAINER INTO RECEPTACLE. VERIFY SLEEVE RETAINER RETENTION FINGERS ARE FULLY SEATED BEHIND RECEPTACLE LATCH BUMPS. RECEPTACLE AND INTERFACE SEAL SHOWN FOR REFERENCE ONLY.

- 4. MATERIAL: PLASTIC
 - 3. PART DESIGNED TO FIT DTP04-4P-**** (**** = ALL MODIFICATIONS) CONSULT FACTORY FOR MODIFICATIONS.
 - 2. DIMENSIONS ARE ±.025 [.64]
 - 1. DIMENSIONS ARE IN INCHES [mm]
- NOTES: UNLESS OTHERWISE SPECIFIED

REV
A 1011-118-0405

REVISIONS			
SYM	DESCRIPTION	DATE	APPROVED
NC	NEW RELEASE PER E.O. P16143	6-21-99	R.D.R.
A	REVISED, REDRAWN PER E.O. P18261	8-14-03	RDR

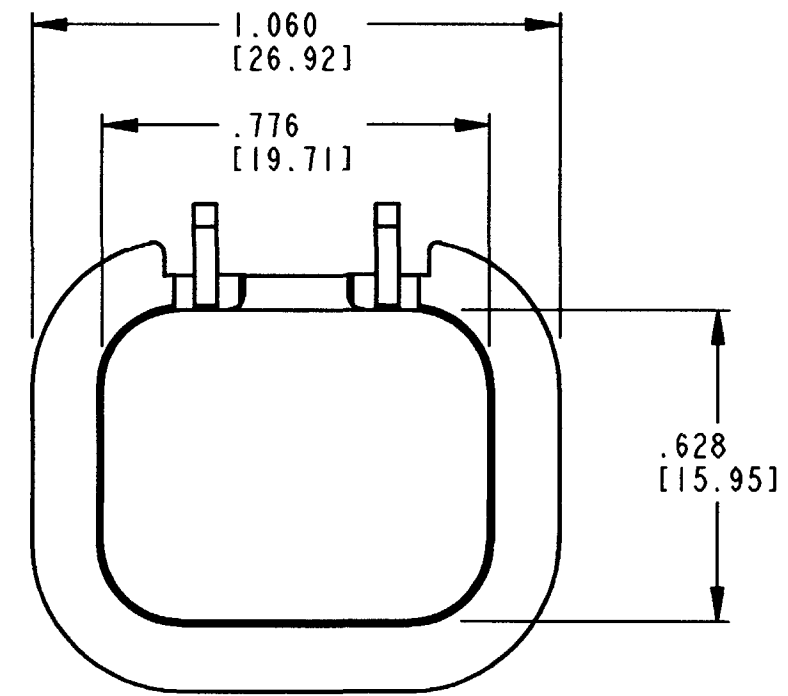
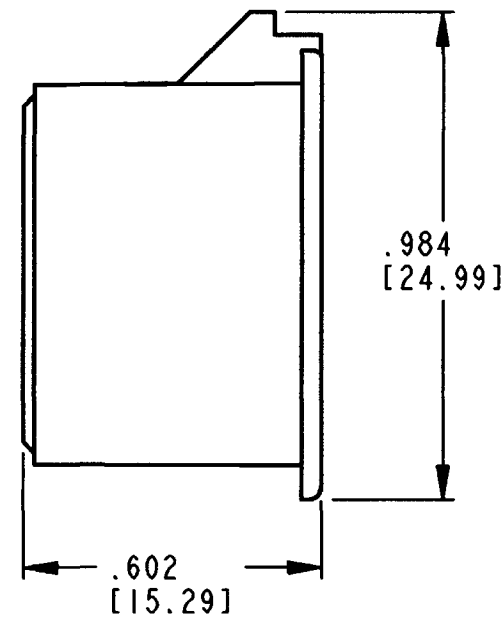
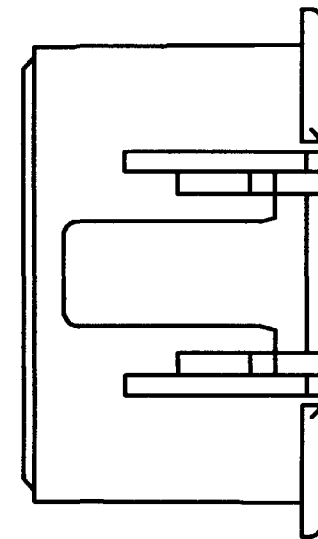

SIGNATURE & DATE	
DR	V. TOMSA AUG-11-03
CHK	<i>James C. Gorton</i> 8/14/03
PE	<i>Vladimir Tomsa</i> AUG-11-03
APPD	<i>D. Meyer</i> 8/14/03
SCALE	NONE

SLEEVE RETAINER
FOR 4 PIN RECEPTACLE
COLOR: GREY
DTP SERIES

ENVELOPE

CP EP 039	MATL. CODE
The Deutch Company	
DEUTSCH I.P.D. 3850 INDUSTRIAL AVE. HEMET, CALIF. 92545	
B	1011-118-0405
DWG SIZE 11139	SHEET OF