



UC3656

CMOS IC

1.6MHz, 1A SYNCHRONOUS BUCK CONVERTER

DESCRIPTION

The UTC **UC3656** is a synchronous buck converter for a DC/DC converter optimized for high-performance microprocessor applications.

It is configured with current mode for excellent line and load transient response. At 1.6MHz operation frequency, the use of small surface mount inductor and capacitor is enabled. The built-in synchronous switch saves the use of an external Schottky diode and increases efficiency.

The UTC **UC3656** is a low-noise synchronous step-down DC/DC converter that is ideally suited for systems requiring supplies from a 1-cell Li-ion battery or from a 3-cell to 4-cell NiCd, NiMH, or alkaline battery.

The UTC **UC3656** is generally applied in power supply for portable devices and USB-based power system.

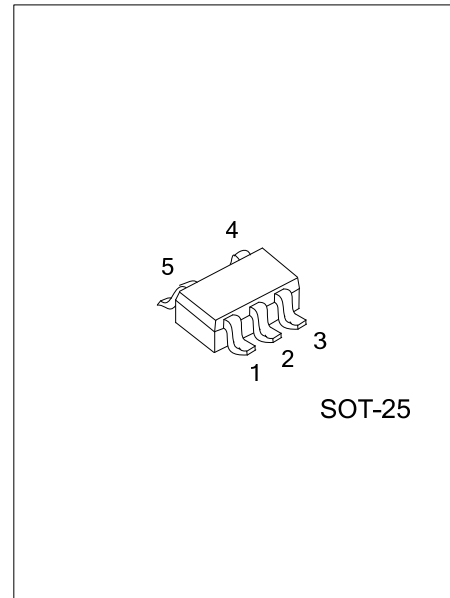

FEATURES

- * High Efficiency
- * Input Voltage Range: 2.5V ~ 5.5V
- * Schottky Diode is Saved
- * Output Current: 1000mA (@5V Input 3.3V Output)
- * 1.6MHz Oscillation Frequency
- * Internal ON/OFF
- * 100% Duty Cycle Allows Low Dropout Operation
- * Stand-by Current: 1µA (Max.)

ORDERING INFORMATION

Ordering Number		Package	Packing
Lead Free	Halogen Free		
UC3656L-AF5-R	UC3656G-AF5-R	SOT-25	Tape Reel

<p>UC3656G-AF5-R</p> <ul style="list-style-type: none"> (1)Packing Type (2)Package Type (3)Green Package 	<ul style="list-style-type: none"> (1) R: Tape Reel (2) AF5: SOT-25 (3) G: Halogen Free and Lead Free, L: Lead Free
---	--

MARKING

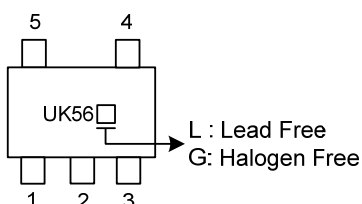

■ PIN CONFIGURATION

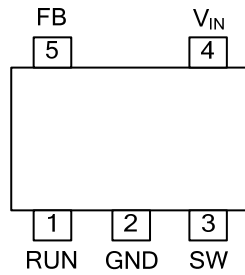

■ PIN DESCRIPTION

PIN NO.	PIN NAME	DESCRIPTION
1	Run	ON/OFF Control
2	GND	Power Ground
3	SW	Switch Node Connection to Inductor
4	V _{IN}	Power Supply
5	FB	Output Feedback

■ BLOCK DIAGRAM

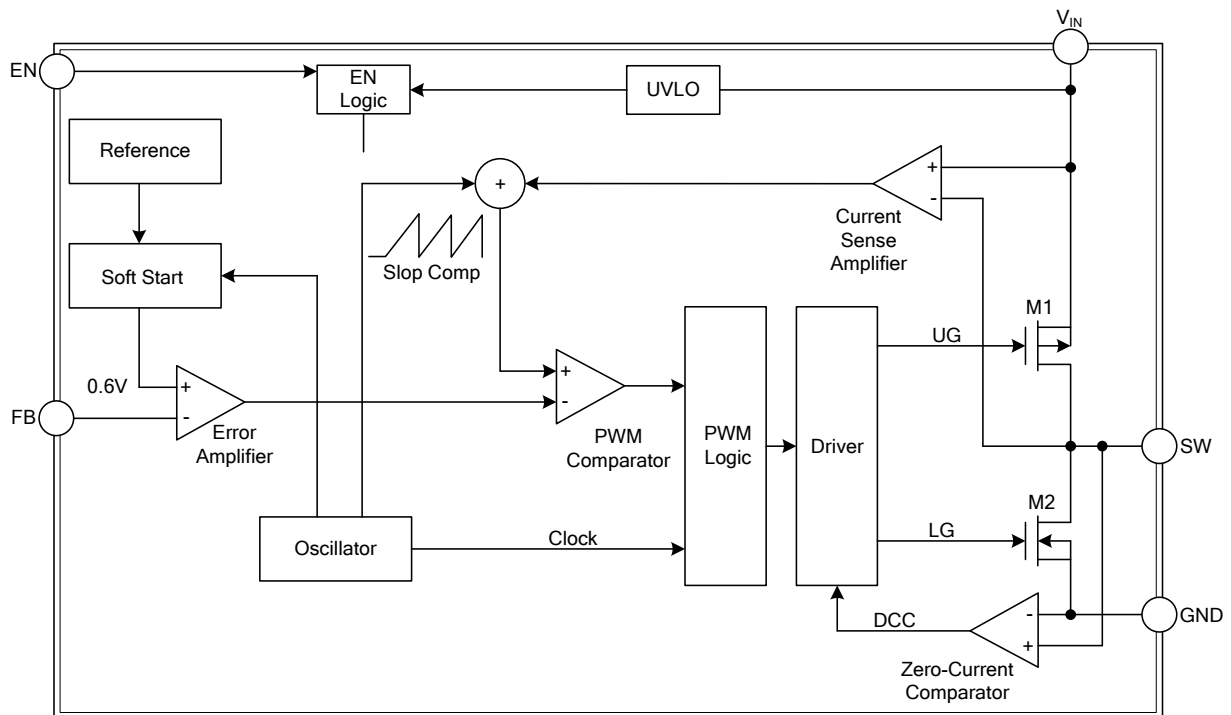

■ ABSOLUTE MAXIMUM RATING

PARAMETER	SYMBOL	RATINGS	UNIT
Power Supply Voltage	V_{SS}	-0.3 ~ +6.0	V
Input Pin Voltage	RUN, FB	V_{IN}	-0.3 ~ V_{IN}
	SW	V_{IN}	-0.3 ~ $V_{IN} + 0.3$
P-Channel Switch Source Current (DC)		1000	mA
N-Channel Switch Sink Current (DC)		1000	mA
Peak SW Sink and Source Current		1.5	A
Junction Temperature	T_J	+150	°C
Operating Temperature	T_{OPR}	-20 ~ +85	°C
Storage Temperature	T_{STG}	-55 ~ +150	°C

Note: Absolute maximum ratings are those values beyond which the device could be permanently damaged.

Absolute maximum ratings are stress ratings only and functional device operation is not implied.

■ THERMAL DATA

PARAMETER	SYMBOL	RATINGS	UNIT
Junction to Ambient	θ_{JA}	165	°C/W

■ ELECTRICAL CHARACTERISTICS ($V_{IN}=3.6V$, $T_A=25^\circ C$, unless otherwise specified.)

PARAMETER	SYMBOL	TEST CONDITIONS	MIN	TYP	MAX	UNIT
Input Supply Range	V_{IN}		2.5		5.5	V
Under Voltage Lockout				2.4		V
Quiescent Current (Note)	I_S	FB=0.6V, $I_{LOAD}=0A$, Active Mode		300		μA
Current In Standby Mode	I_{ST}	RUN=0V, $V_{IN}=5.5V$		0.5	1	μA
Feedback Voltage	V_{FB}	$T_A=-20^\circ C \sim +85^\circ C$	0.588	0.6	0.612	V
Feedback Voltage Line-Regulation	$V_{FB-LINE}$	$V_{CC}=2.5V \sim 5.5V$		0.1	0.5	%
Feedback Variation with Temperature		$T_A=-20^\circ C \sim +85^\circ C$		0.5	1.0	%
Feedback Current	I_{FB}				± 200	nA
Peak Inductor Current (Note)	I_{PK}	$V_{IN}=5V$, $V_{OUT}=3.3V$	1.10	1.25	1.50	A
Maximum Output Current (Note)	I_O	$V_{IN}=5V \pm 5\%$, $V_{OUT}=3.3V$, $L=4.7\mu H$			1000	mA
Oscillator Frequency	f_{OSC1}		0.8	1.6	2.0	MHz
	f_{OSC2}	FB=0V		200		KHz
Short Current	I_{SC}	FB<0.3V		300		mA
Soft-start time	T_{SS}			2.8		mS
$R_{DS(ON)}$ of P-Channel MOSFET	R_{PFET}	$I_{SW}=600mA$		0.4	0.5	Ω
$R_{DS(ON)}$ of N-Channel MOSFET	R_{NFET}	$I_{SW}=-600mA$		0.35	0.45	Ω
SW Leakage Current	I_{LSW}	RUN=0V, SW=0V or 5V, $V_{IN}=5V$		± 0.1	± 1	μA
RUN Threshold	V_{RUN}		0.3	1.0	1.5	V
RUN Leakage Current	I_{RUN}			± 0.1	± 1	μA

Note: $I_{PK} = I_O + \frac{\Delta I}{2} = I_O + \frac{(V_{IN} - V_{OUT}) \times t_{ON}}{2 \times L}$

■ TYPICAL APPLICATION CIRCUIT

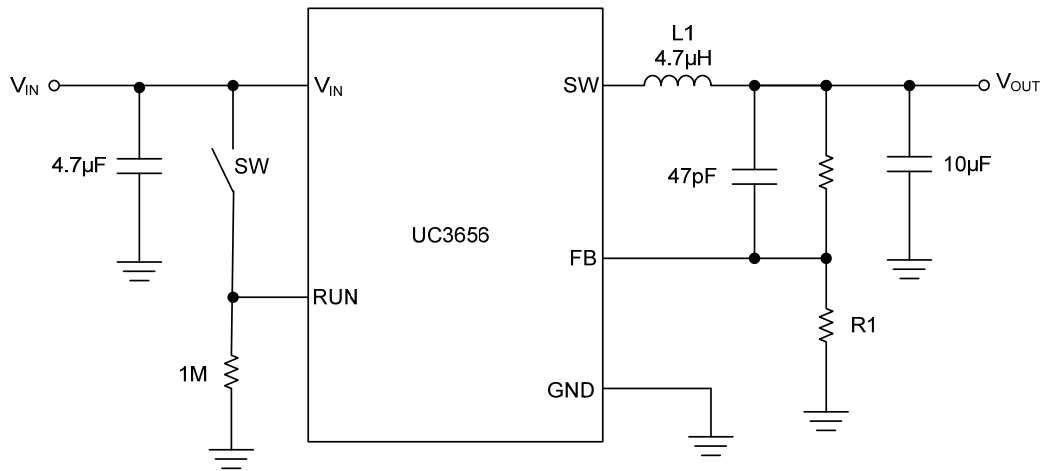

Fig. 1

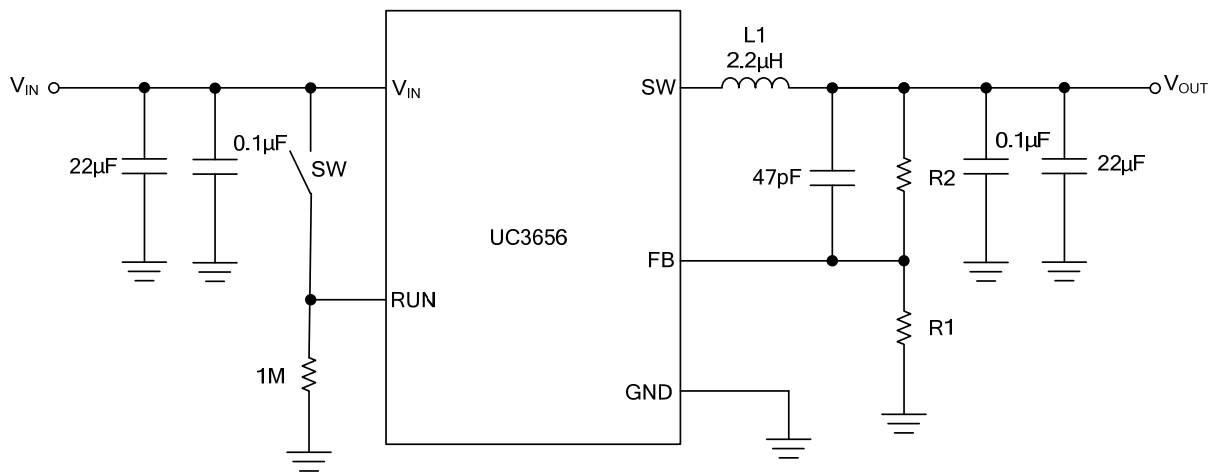

Fig. 2

■ APPLICATION INFORMATION

Capacitor Selection

Proper selection of capacitors using the UTC **UC3656** plays a critical role for system performance. The source current of the top MOSFET is square wave of duty cycle in a continuous mode.

The input capacitor is generally used to provide a low impedance loop for the edges of pulsed current drawn by the UTC **UC3656**. A load step at the output can induce ringing at the input V_{IN} . This ringing can couple to the output and be mistaken as loop instability. Increasing the capacitance of the input capacitor can greatly improve the oscillation. A typical value is 4.7~ 22 μ F ceramic (X5R or X7R), POSCAP or Aluminum Polymer. With these capacitors, better high frequency bypassing is achieved; resistive losses are thus reduced by their low ESR for higher efficiency. Moreover, the input capacitor RMS current changes with the input voltage and the output voltage.

The maximum RMS current in the input capacitor can be expressed in the following formula:

$$I_{RMS} = I_{OMAX} \sqrt{\frac{V_O}{V_{IN}} \left(1 - \frac{V_O}{V_{IN}}\right)}$$

The output capacitor depends upon the suitable ripple voltage. Low ripple voltage corresponds to lower effective series resistance (ESR).

The output ripple voltage can be calculated by: $\Delta V_{OUT} \cong \Delta I_L \left(ESR + \frac{1}{8fC_{OUT}}\right)$

The formula as follows shows the output capacitor RMS ripple current: $I_{RMS} = \frac{1}{2\sqrt{3}} \frac{V_{OUT} \times (V_{IN} - V_{OUT})}{L \times f \times V_{IN}}$

For the UTC **UC3656**, X5R or X7R dielectric formulations have the priority in choosing the input and output ceramic capacitors. This is because these dielectrics provide the best temperature and voltage characteristics of all the ceramics for a given value and size.

Inductor Selection

Selecting an optimum inductor is dependent upon the expected ripple current and large value inductors lower ripple current and small value inductors result in higher ripple current. In addition, the losses associated with the DCR and its effect on the total converter efficiency should be taken consideration.

The inductor is also chosen to limit the ripple current to some pre-fixed value, approx. 20 ~ 40% (TYP.) of the full load current at the maximum input voltage.

The inductance value can be calculated in the following equation:

$$\Delta I_L = 0.2 \sim 0.4 \times I_{OUT(MAX)}$$

$$L = \frac{V_{OUT}}{f \times \Delta I_L} \left(1 - \frac{V_{OUT}}{V_{IN}}\right)$$

■ APPLICATION INFORMATION (Cont.)

Adjustable Output Voltage

A resistive divider adjusts the output voltage of the UTC **UC3656**, which divides a 0.6V reference voltage at FB pin. The output voltage can be obtained by the equation as follows:

$$V_{OUT} = 0.6V \times \left(1 + \frac{R_2}{R_1}\right)$$

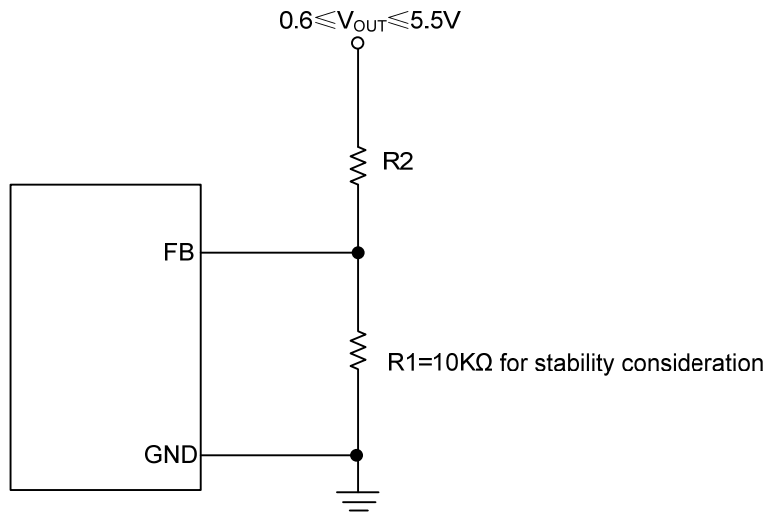

TYPICAL CHARACTERISTICS

$V_{IN}=3.6V$, $V_{RUN}=2.0V$, $L=4.7\mu H$, $R_2=300K\Omega$, $R_1=150K\Omega$

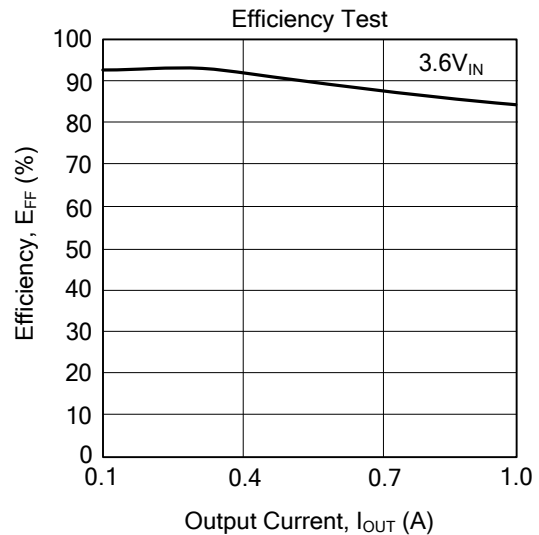
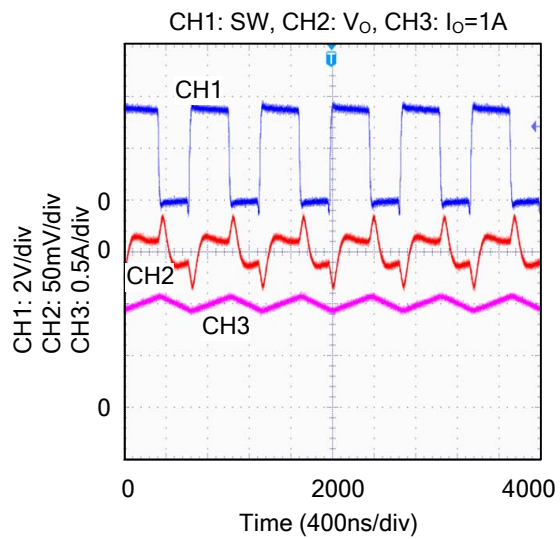
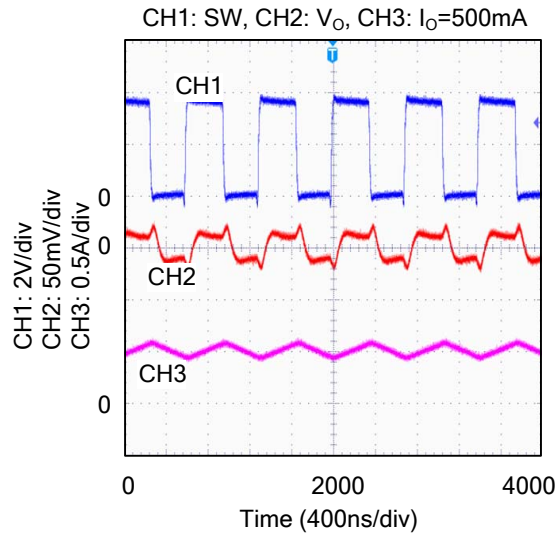
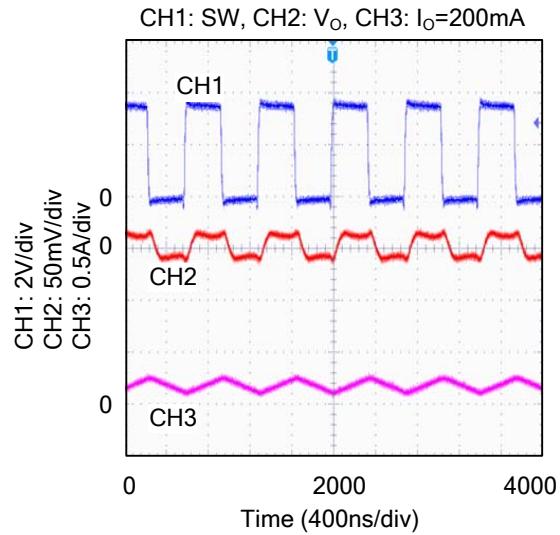

UTC assumes no responsibility for equipment failures that result from using products at values that exceed, even momentarily, rated values (such as maximum ratings, operating condition ranges, or other parameters) listed in products specifications of any and all UTC products described or contained herein. UTC products are not designed for use in life support appliances, devices or systems where malfunction of these products can be reasonably expected to result in personal injury. Reproduction in whole or in part is prohibited without the prior written consent of the copyright owner. UTC reserves the right to make changes to information published in this document, including without limitation specifications and product descriptions, at any time and without notice. This document supersedes and replaces all information supplied prior to the publication hereof.