

# APPROVAL SHEET

**WR12X / WR08X / WR06X**

**±1%, ±5%**

General purpose chip resistors

Size 1206 / 0805 / 0603

Customer : \_\_\_\_\_  
Approval No : \_\_\_\_\_  
Issue Date : \_\_\_\_\_

Customer Approval :

## FEATURE

1. High reliability and stability
2. Reduced size of final equipment
3. Lower assembly costs
4. Higher component and equipment reliability
5. Lead free products upon customer requested

## APPLICATION

- Consumer electrical equipment
- Automotive application
- EDP, Computer application
- Telecom application

## DESCRIPTION

The resistors are constructed in a high grade ceramic body (aluminum oxide). Internal metal electrodes are added at each end and connected by a resistive paste that is applied to the top surface of the substrate. The composition of the paste is adjusted to give the approximate resistance required and the value is trimmed to within tolerance by laser cutting of this resistive layer.

The resistive layer is covered with a protective coat. Finally, the two external end terminations are added. For ease of soldering the outer layer of these end terminations is a Lead-tin or Tin (lead free) alloy.

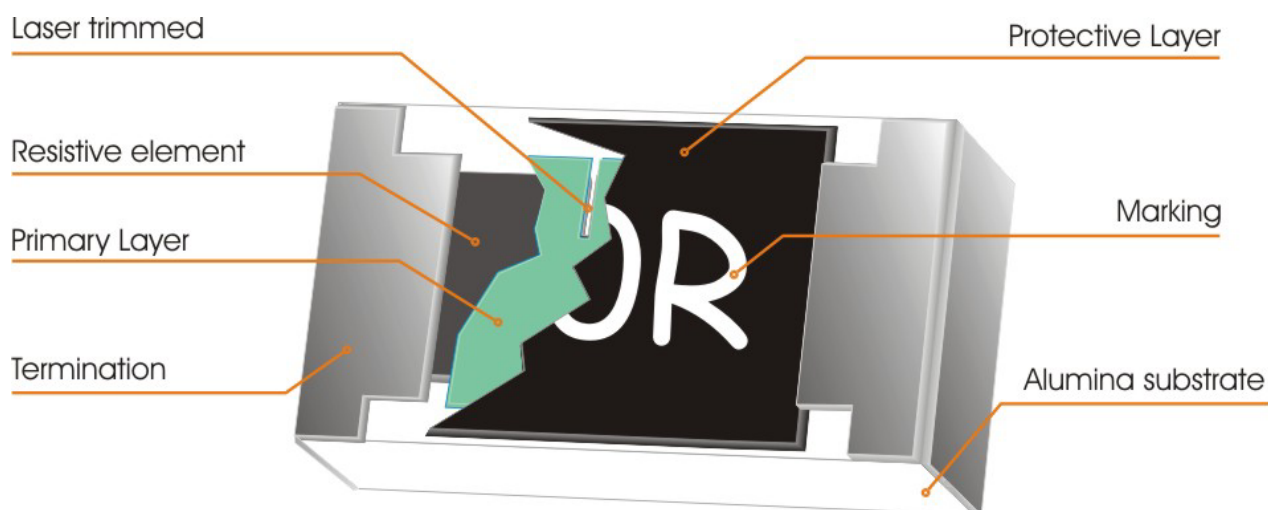

Fig 1. Construction of a Chip-R

QUICK REFERENCE DATA

Item	General Specification					
Series No.	WR12		WR08		WR06	
Size code	1206(3216)		0805(2012)		0603(1608)	
Resistance Range	1Ω~10MΩ(±5% tolerance), 10Ω~1MΩ(±1% tolerance), Jumper					
Resistance Tolerance	±1% E96/E24	±5% E24	±1% E96/E24	±5% E24	±1% E96/E24	±5% E24
TCR (ppm/°C)						
R≥1MΩ		≤ ± 200		≤ ± 200		≤ ± 200
1MΩ > R > 10Ω	≤ ± 100	≤ ± 200	≤ ± 100	≤ ± 200	≤ ± 100	≤ ± 200
R≤10Ω	-300~+500	-300~+500	-300~+500	-300~+500	-300~+500	-300~+500
Max. dissipation @ T <sub>amb</sub> =70°C	1/4 W		1/8 W		1/10 W	
Max. Operation Voltage (DC or RMS)	200V		150V		50V	
Max. Overload Voltage (DC or RMS)	400V		300V		100V	
Climatic category (IEC 60068)	55/155/56					

Note :

- This is the maximum voltage that may be continuously supplied to the resistor element, see “IEC publication 60115-8”
- Max. Operation Voltage : So called RCWV (Rated Continuous Working Voltage) is determined by  

$$RCWV = \sqrt{\text{Rated Power} \times \text{Resistance Value}}$$
 or Max. RCWV listed above, whichever is lower.
- The resistance range 1~10Ω and 1M ~10MΩ with 1% tolerance please refer to WR12W / WR08W / WR06W series.
- The resistance of Jumper is defined <0.05Ω.

DIMENSIONS

	WR12X	WR08X	WR06X
<b>L</b>	3.10 ± 0.10	2.00 ± 0.10	1.60 ± 0.10
<b>W</b>	1.60 ± 0.10	1.25 ± 0.10	0.80 ± 0.10
<b>T</b>	0.60 ± 0.15	0.50 ± 0.15	0.45 ± 0.15
<b>Tb</b>	0.45 ± 0.20	0.40 ± 0.20	0.30 ± 0.15
<b>Tt</b>	0.50 ± 0.20	0.40 ± 0.20	0.30 ± 0.10

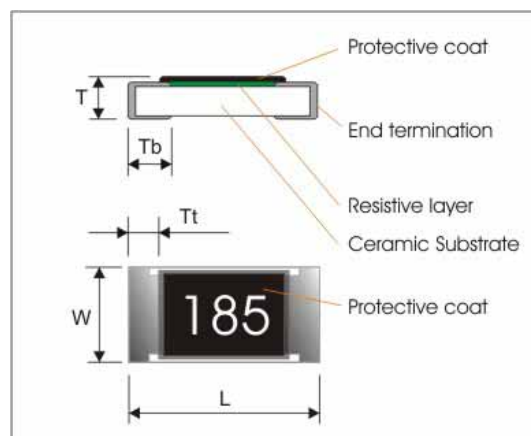



**MARKING**

Size \ Nr. Of digit of code\tolerance	±5%	±1%
<b>1206 (3216)</b>	3-digits marking	4-digits marking
<b>0805 (2012)</b>	3-digits marking	4-digits marking
<b>0603 (1608)</b>	3-digits marking	3-digits marking

**3-digits marking** ( ±5% : 1206 & 0805 & 0603 )

Each resistor is marked with a three digits code on the protective coating to designate the nominal resistance value. For values up to 91Ω the R is used as a decimal point. For values of 100Ω or greater the first 3 digits apply to the resistance value and fourth indicate the number of zeros to follow.(EX. Jumper(0Ω) can be 0 or 000)

**3-digits marking** ( ±1% : 0603 )

Nominal resistance	Description														
1.E-24 series	As 0603 WR06X ±5%.														
2.E-96 series	The 1st two digit codes are referring to the CODE on the table, the 3rd code is the index of resistance value : Y=10 <sup>-2</sup> , X=10 <sup>-1</sup> , A=10 <sup>0</sup> , B=10 <sup>1</sup> , C=10 <sup>2</sup> , D=10 <sup>3</sup> , E=10 <sup>4</sup> , F=10 <sup>5</sup> EX : 17.8 =25X, 178 =25A, 1K78 =25B 17K8=25C, 178K=25D, 1M78=25E														
3. Remark	There is no marking for the items are not under E-24 and E-96 series														
<b>CODE</b>	<b>R_value</b>	<b>CODE</b>	<b>R_value</b>	<b>CODE</b>	<b>R_value</b>	<b>CODE</b>	<b>R_value</b>	<b>CODE</b>	<b>R_value</b>	<b>CODE</b>	<b>R_value</b>	<b>CODE</b>	<b>R_value</b>	<b>CODE</b>	<b>R_value</b>
01	100	13	133	25	178	37	237	49	316	61	422	73	562	85	750
02	102	14	137	26	182	38	243	50	324	62	432	74	576	86	768
03	105	15	140	27	187	39	249	51	332	63	442	75	590	87	787
04	107	16	143	28	191	40	255	52	340	64	453	76	604	88	806
05	110	17	147	29	196	41	261	53	348	65	464	77	619	89	825
06	113	18	150	30	200	42	267	54	357	66	475	78	634	90	845
07	115	19	154	31	205	43	274	55	365	67	487	79	649	91	866
08	118	20	158	32	210	44	280	56	374	68	499	80	665	92	887
09	121	21	162	33	215	45	287	57	383	69	511	81	681	93	909
10	124	22	165	34	221	46	294	58	392	70	523	82	698	94	931
11	127	23	169	35	226	47	301	59	402	71	536	83	715	95	953
12	130	24	174	36	232	48	309	60	412	72	549	84	732	96	976

**4-digits marking** ( ±1% : 1206/0805 )

Each resistor is marked with a four digits code on the protective coating to designate the nominal resistance value. For values of <97.6Ω the R is used as a decimal point. For values of 100Ω or greater the first 3 digits are significant, the fourth indicates the number of zeros to follow.

**Example**

RESISTANCE	10Ω	12Ω	100Ω	6800Ω	0Ω
<b>3-digits marking ( 1206 &amp; 0805 &amp; 0603 ±5% )</b>	100	120	101	682	<b>0 or 000</b>
<b>4-digits marking</b>	10R0	12R0	1000	6801	----

## FUNCTIONAL DESCRIPTION

### Product characterization

Standard values of nominal resistance are taken from the E24 series for resistors with a tolerance of  $\pm 5\%$ , and E96 series for resistors with a tolerance of  $\pm 1\%$ . The values of the E24/E96 series are in accordance with "IEC publication 60063"

### Derating

The power that the resistor can dissipate depends on the operating temperature; see Fig.2

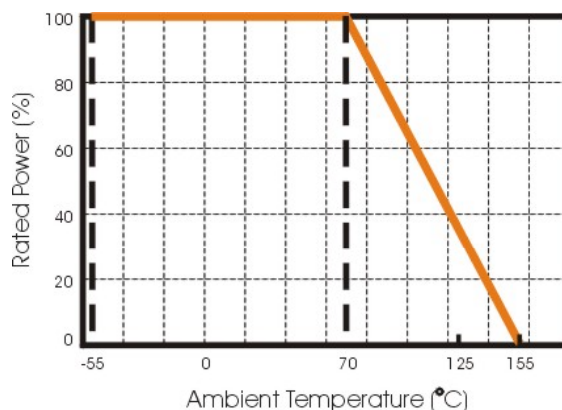

**Figure 2. Maximum dissipation in percentage of rated power  
As a function of the ambient temperature**

## MOUNTING

Due to their rectangular shapes and small tolerances, Surface Mountable Resistors are suitable for handling by automatic placement systems.

Chip placement can be on ceramic substrates and printed-circuit boards (PCBs).

Electrical connection to the circuit is by individual soldering condition.

The end terminations guarantee a reliable contact.

## SOLDERING CONDITION

The robust construction of chip resistors allows them to be completely immersed in a solder bath of 260°C for one minute. Therefore, it is possible to mount Surface Mount Resistors on one side of a PCB and other discrete components on the reverse (mixed PCBs).

Surface Mount Resistors are tested for solderability at 235°C during 2 seconds. The test condition for no leaching is 260°C for 60 seconds. Typical examples of soldering processes that provide reliable joints without any damage are given in Fig 3.

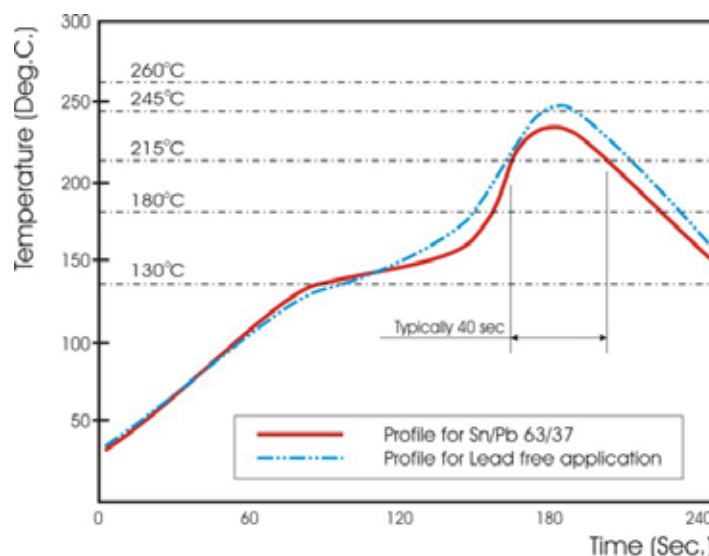

**Fig 3. Infrared soldering profile for Chip Resistors**

## CATALOGUE NUMBERS

The resistors have a catalogue number starting with .

WR12	X	472_	J	T	_
<b>Size code</b>	<b>Type code</b>	<b>Resistance code</b>	<b>Tolerance</b>	<b>Packaging code</b>	<b>Termination code</b>
WR12 : 1206 WR08 : 0805 WR06 : 0603	X : Normal	E24 : 2 significant digits followed by no. of zeros and a blank  4.7Ω =4R7_ 10Ω =100_ 220Ω =221_ Jumper =000_ ("_" means a blank) E96 : 3 significant digits followed by no. of zeros  102Ω =1020 37.4KΩ =3742	F : ±1% J : ±5% P : Jumper	T : 7" Reeled taping Q : 10" Reeled taping G : 13" Reeled taping B : Bulk	_ = SnPb base ("_" means a blank) L = Sn base (lead free)

1. Reeled tape packaging : 8mm width paper taping 5000pcs per 7" reel, 10kpcs per 10" reel, 20kpcs per 13" reel.
2. Bulk packaging : 5000pcs per polybag

**TEST AND REQUIREMENTS(JIS C 5201-1 : 1998)**

Essentially all tests are carried out according to the schedule of IEC publication 115-8, category **LCT/UCT/56**(rated temperature range : **Lower Category Temperature, Upper Category Temperature**; damp heat, long term, 56 days). The testing also meets the requirements specified by EIA, EIAJ and JIS.

The tests are carried out in accordance with IEC publication 68, "Recommended basic climatic and mechanical robustness testing procedure for electronic components" and under standard atmospheric conditions according to IEC 60068-1, subclause 5.3. Unless otherwise specified, the following value supplied :

Temperature: 15°C to 35°C.

Relative humidity: 45% to 75%.

Air pressure: 86kPa to 106 kPa (860 mbar to 1060 mbar).

All soldering tests are performed with mildly activated flux.

**TEST CONDITION FOR JUMPER (0 Ω)**

Item	WR12X	WR08X	WR06X
Power Rating At 70°C	1/4W	1/8W	1/10W
Resistance	MAX.50mΩ		
Rated Current	2A	1.5A	1A
Peak Current	5A	3.5A	3A
Operating Temperature	-55~155°C		

TEST	PROCEDURE / TEST METHOD	REQUIREMENT	
		Resistor	0Ω
DC resistance <b>Clause 4.5</b>	DC resistance values measured at the test voltages specified below : <10Ω@0.1V, <100Ω@0.3V, <1KΩ@1.0V, <10KΩ@3V, <100KΩ@10V, <1MΩ@25V, <10MΩ@30V	Within the specified tolerance	<50mΩ
Temperature Coefficient of Resistance(T.C.R) <b>Clause 4.8</b>	Natural resistance change per change in degree centigrade. $\frac{R_2 - R_1}{R_1(t_2 - t_1)} \times 10^6 \text{ (ppm/}^\circ\text{C)}$ $t_1 : 20^\circ\text{C}+5^\circ\text{C}-1^\circ\text{C}$ R <sub>1</sub> : Resistance at reference temperature R <sub>2</sub> : Resistance at test temperature	Refer to "QUICK REFERENCE DATA"	N/a
Short time overload (S.T.O.L) <b>Clause 4.13</b>	Permanent resistance change after a 5second application of a voltage 2.5 times RCWV or the maximum overload voltage specified in the above list, whichever is less.	ΔR/R max. ±(2%+0.10Ω)	<50mΩ
Resistance to soldering heat(R.S.H) <b>Clause 4.18</b>	Un-mounted chips completely immersed for 10±1second in a solder bath at 270 ±5°C	R/R max. ±(1%+0.05 ) no visible damage	<50mΩ
Solderability <b>Clause 4.17</b>	Un-mounted chips completely immersed for 2±0.5second in a solder bath at 235 ±5	95% coverage min., good tinning and no visible damage	
Leach Test <b>Clause 4.18</b>	Un-mounted chips completely immersed for 60±1second in a solder bath at 260 ±5	Ditto	
Temperature cycling <b>Clause 4.19</b>	30 minutes at -55°C±3°C, 2~3 minutes at 20°C+5°C-1°C, 30 minutes at +155°C±3°C, 2~3 minutes at 20°C+5°C-1°C, total 5 continuous cycles	ΔR/R max. ±(1%+0.05Ω)	< 50mΩ
Damp Heat (Load life in humidity) <b>Clause 4.24</b>	1000+48/-0 hours; 1.5hours ON, 0.5hours OFF at RCWV in a humidity chamber controlled 40±2°C, 90~95% RH	10Ω≤R<1MΩ : ΔR/R max. ±(3%+0.10Ω) R<10Ω, R≥1MΩ : ΔR/R max. ±(5%+0.10Ω)	< 50mΩ
Load Life (Endurance) <b>Clause 4.25</b>	1000+48/-0 hours; loaded with P <sub>n</sub> or V <sub>max</sub> ; 1.5 hours ON, 0.5 hours OFF	Ditto.	
Bending strength <b>Clause 4.33</b>	Resistors mounted on a 90mm glass epoxy resin PCB(FR4), bending once 3mm for 10sec.	No visual damaged, ΔR/R max. ±(1%+0.05Ω)	< 50mΩ
Adhesion <b>Clause 4.32</b>	Pressurizing force: 5N, Test time: 10±1sec.	No remarkable damage or removal of the terminations	

PACKAGING

Paper Tape specifications (unit :mm)

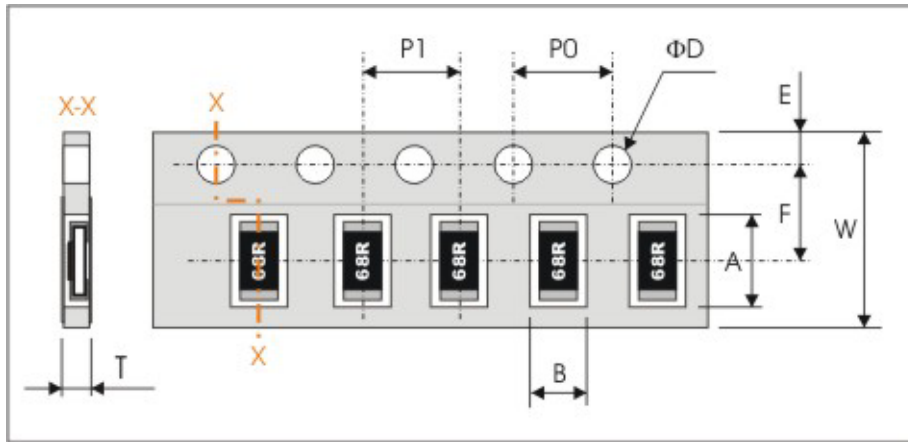

Series No.	A	B	W	F	E
WR12X	3.60±0.20	2.00±0.20	8.00±0.30	3.50±0.20	1.75±0.10
WR08X	2.40±0.20	1.65±0.20	8.00±0.30	3.50±0.20	1.75±0.10
WR06X	1.90±0.20	1.10±0.20	8.00±0.30	3.50±0.20	1.75±0.10

Series No.	P1	P0	ΦD	T
WR12X / WR08X	4.00±0.10	4.00±0.10	Φ1.50 <sup>+0.1</sup> <sub>-0.0</sub>	Max. 1.0
WR06X	4.00±0.10	4.00±0.10	Φ1.50 <sup>+0.1</sup> <sub>-0.0</sub>	0.65±0.05

7" Reel dimensions

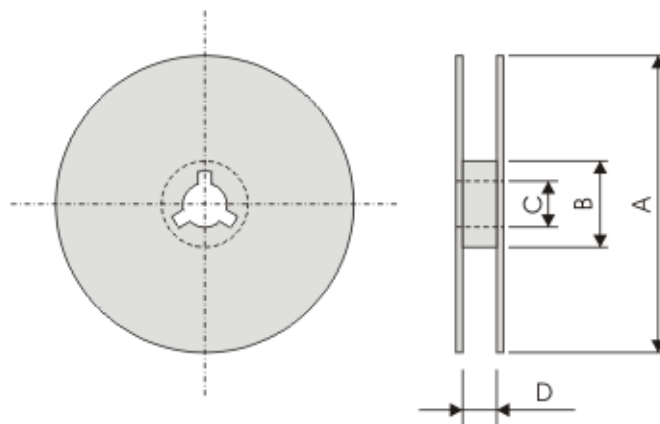

Symbol	A	B	C	D
(unit : mm)	Φ178.0±2.0	Φ60.0±1.0	13.0±0.2	9.0±0.5