

BEG500KTL-A

Non-Isolated Grid-tied Converter



Wide-range of DC input voltage
DSP control, true sine-wave outputs
High Efficiency, High Power Factor
Advanced IGBT power devices

Perfect DC/AC Protection
RS485/CAN/Ethernet/
GSM communication interface(optional)
Auxiliary electric heating(optional)

Low voltage ride-through,
reactive power adjustable, act
CQC Certification

System Diagram

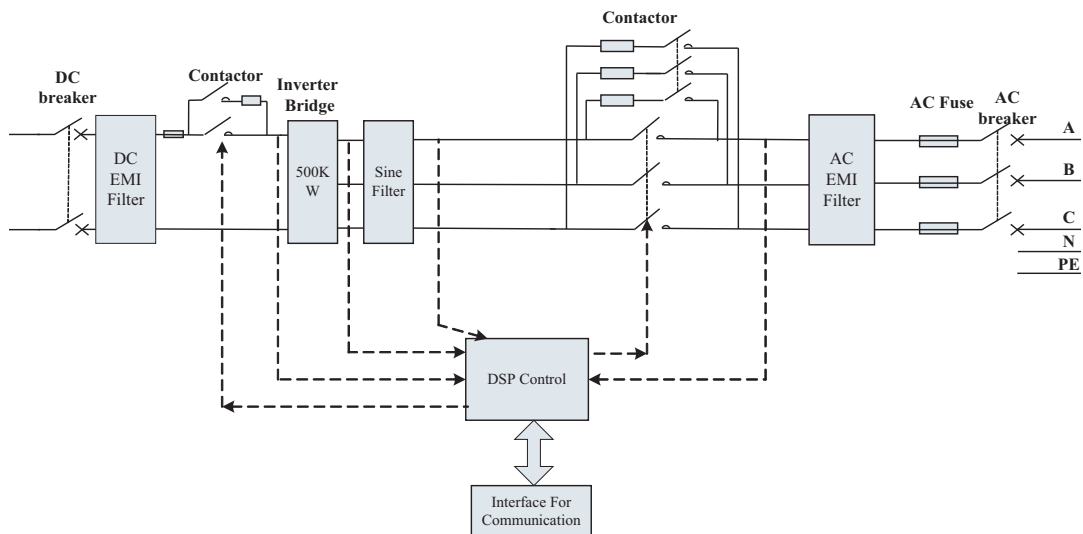

Technical Data

DC Side Data	
Max. DC Voltage	1000Vdc
DC Voltage Range	700~900Vdc
Nominal Power(Charge)	500kW
Nominal Power(Discharge)	508kW
Max. Permissible DC Current	857A
AC Side Data	
Nominal AC Power(Discharge)	500kW
Nominal AC Power(Charge)	508kW
Permissible Grid Voltage;Range	400V;340-440V
Permissible Grid Frequency; Range	50Hz;48-50.5Hz
Power Factor	≥0.99(Nominal power)
THD of AC Current	< 5%(Nominal power)
System Data	
Max Efficiency	98.4%
Isolation Method	Transformerless
Degree of Protection	Ip20 (Indoor)
Cooling Method	Controlled forced-air cooling
Noise	< 70dB
Permissible Altitude	2000M
Permissible Ambient Temperature	-25~+55°C
Permissible Relative Humidity	0~95%,(Non-condensing)
Display and Communication	
Display	Touch controlpanel
Communication Method	Ethernet
Protect Function	
Short Circuit Protection	Yes
Overload Protection	Yes
DC Over/Under Voltage Protection	Yes
AC Over/Under Voltage Protection	Yes
AC Over/Under Frequency Protection	Yes
Over Temperature Protection	Yes
DC Reverse Connection Protection	Yes
Islanding Protection	Active and passive control
Mechanical Dimensions	
Dimension (L×D×H)	2320×1040×2200mm
Weight	2200kg
Reference Standard	GB/T 19939-2005; IEC 62109 ;IEC 62116