



Scan this tag to get the latest product information for the New Family of Disconnect Switches and Accessories.



Disconnect Switches

Section Contents

	Page
Compact Circuit Protector (CCP) disconnect switches	
30A Class CC, Midget & 10x38	380-381
30A 60A and 100A Class CF	382-383
CCPB - Compact Circuit Protector Base	384-385
UL 98 fused disconnect switches 30 to 800A	
Introduction & Agency Information.....	386
Product Line Summary.....	387
30A Compact Class CC & Class J	388-389
30A Class J.....	390-391
60A Compact Class J	392-393
60A Class J.....	394-395
100A Class J.....	396-397
200A & 400A Class J	398-400
600A Class J and 800A Class L	402-403
UL 98 non-fused disconnect switches 30 to 1200A	
Introduction & Agency Information.....	404
Product Line Summary.....	405
30A, 60A and 100A Compact	406-407
100A, 200A and 400A Standard	408-409
600A, 800A, 1000A and 1200A Standard.....	410-411
UL 508 non-fused disconnect switches 16 to 80A	
Introduction and Agency Information.....	412
Product Line Summary.....	413
16A, 25A, 40A, 63A and 80A Standard	414-416
Enclosed UL 98 & UL 508 disconnect switches	
Introduction & Agency Information.....	417
Fused UL 98	
30A to 800A Enclosed Disconnects	418-419
Non-Fused UL 98	
30 to 1200A Enclosed Disconnects.....	420-421
Non-Fused UL 508	
16 to 80A Enclosed Disconnects.....	422-423
Fused, dead front disconnect switches	424

Compact Circuit Protector (CCP) Disconnect Switch—30A

1-, 2- & 3-Pole, Class CC, UL Midget & 10x38mm IEC



Switch											
Amp Rating	Fuse Class	Number of Poles	Volts	SCCR	Max Horsepower Rating				Wire Size	Wire Type*	Part Number
					120 Vac	240 Vac	480 Vac	600 Vac			
30	CC	1	600Vac	200kA	0.5	—	—	—	Single/Dual #18-6 Sol/Str	75°C Cu	CCP-1-30CC
30	CC	2	600Vac	200kA	—	2	—	—		75°C Cu	CCP-2-30CC
30	CC	3	600Vac	200kA	—	3	4	7.5		75°C Cu	CCP-3-30CC
30	UL Midget	1	240Vac†	10kA†	—	—	—	—	Single #4 Sol/Str	75°C Cu	CCP-1-30M
32**	10x38 IEC		400Vac†	120kA†							
30	UL Midget	2	240Vac†	10kA†	—	—	—	—		75°C Cu	CCP-2-30M
32**	10x38 IEC		400Vac†	120kA†							
30	UL Midget	3	240Vac†	10kA†	—	—	—	—	Spade Terminal††	75°C Cu	CCP-3-30M
32**	10x38 IEC		400Vac†	120kA†							
30	CC	1	80Vdc†	20kA†	—	—	—	—		75°C Cu	CCP-1-30DCC
30	CC	1	80Vdc†	10kA†	—	—	—	—		75°C Cu	CCP-1-30DCM

* 75°C or higher.
 ** 32A Class aM, 25A Class gG.
 † SCCR May be lower, refer to installed fuse data sheets.
 †† Spade terminal, 30A max, insulated flange, wire size #12-10 for #8 stud.

Specifications

Agency Information

- CE Compliant
- RoHS Compliant
- For **Class CC** fuse version
 - UL 98 Listed, File E302370, Guide WHTY
 - cULus to CSA Standard 22.2 No. 4-04, File 302370, Guide WHTY7
- For **UL Midget and 10X38 IEC** fuse version
 - UL 508 Listed, File E161278, Guide 8R29
 - cULus Certified 22.2 No. 14-05
 - IEC 60947-3 AC23A
 - IEC 60947-3 DC23A

Terminals

- Single/dual conductor box lug or spade terminal suitable for line, load or accessory connection
- Torque: - #18-10 20Lb-In
 - #8-4 35Lb-In

Storage and Operating Temperature

- -20°C to 75°C*
- * For fuse performance under or above 25°C, consult fuse performance derating charts in the Bussmann publication titled *Selecting Protective Devices (SPD)*, reorder #3002.

Flammability Rating UL 94V0

Lockout/Tagout Provisions

- 4mm shank lock or standard pin-out devices

Mounting

- 35mm DIN-Rail

Local Open Fuse Indication Minimum Voltage**

- 90Vac for AC versions
- 12Vdc for DC versions

** Circuit must be closed for indication light to illuminate.

Features

- IP20 Finger-safe construction with #10 or larger wire
- Switch interlock prohibits removing the fuse under load

Accessories

- Auxiliary contacts
- PLC Wired remote fuse indication

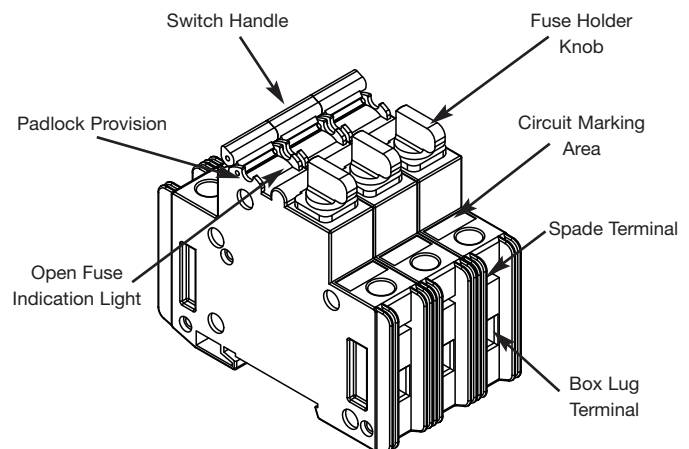

Available Bussmann Fuses

Class	Type	Data Sheet #
CC	LP-CC Time-Delay, Current Limiting	1023
CC	FNQ-R Time-Delay	1014
CC	KTK-R Fast-Acting	1015
M	FNM Time-Delay	2028
M	FNQ Time-Delay	1012
M	KTK Fast-Acting	1011
M	BAF Fast-Acting	2011
M	KLM Fast-Acting 600Vac/dc	2020

Data Sheet: 1157

Compact Circuit Protector (CCP) Disconnect Switch—30A 1-, 2- & 3-Pole, Class CC, UL Midget & 10x38mm IEC

Dimensions – mm (in)

Class CC, UL Midget & 10x38 IEC

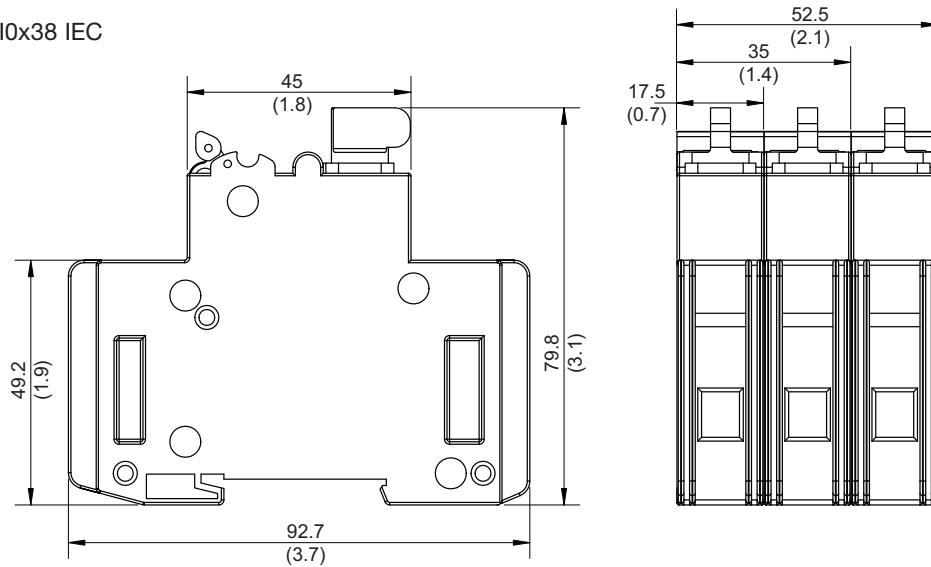

Disconnect
Switches

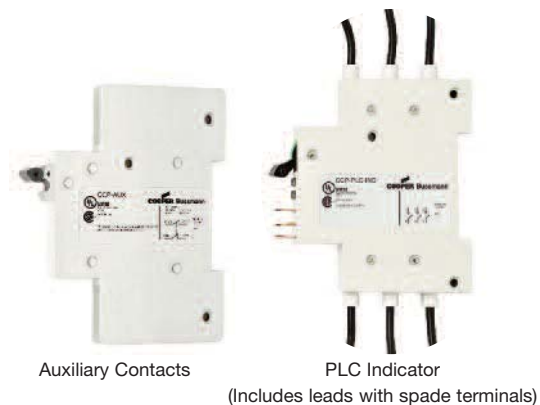

CCP-30 Accessories					
Description	Configuration	Signal Output	Minimum Circuit Voltage	Agency Information	Part Number
Auxiliary Contacts NO+NC for Switch Status	1 per CCP	5A/240Vac	-	UL 98 Recognized, cURus 22.2 No. 4-04, IEC 60947-5-1 AC15	CCP-AUX*
Wired Remote Fuse Indication for PLC Applications	1 per CCP	24Vdc	100Vac	UL 98 Recognized, cURus 22.2 No. 4-04	CCP-PLC-IND*
* Refer to Data Sheet # 1157 for details.					

Compact Circuit Protector (CCP) Disconnect Switch—30, 60 & 100A 1-, 2- & 3-Pole, Class CF CUBEFuse™



Switch											
Amp Rating	Fuse Class	Number of Poles	Volts	SCCR	Max Horsepower Rating				Wire Size	Wire Type*	Part Number
					120 Vac	240 Vac	480 Vac	600 Vac			
30	CF	1	600Vac 125Vdc	200kA	1.5	—	—	—	Single/Dual #18-6 Sol/Str	75°C Cu	CCP-1-30CF
30	CF	2	600Vac 125Vdc	200kA	—	3	—	—		75°C Cu	CCP-2-30CF
30	CF	3	600Vac 125Vdc	200kA	—	5	15	10	Single #4 Sol/Str	75°C Cu	CCP-3-30CF
60	CF	1	600Vac 125Vdc	200kA	3	—	—	—		Spade Terminal**	75°C Cu
60	CF	2	600Vac 125Vdc	200kA	—	7.5	—	—	75°C Cu		CCP-2-60CF
60	CF	3	600Vac 125Vdc	200kA	—	7.5	20	10	75°C Cu		CCP-3-60CF
100	CF	1	600Vac	200kA	5	—	—	—	Single #8-10 Sol/Str	75°C Cu	CCP-1-100CF
100	CF	2	600Vac	200kA	—	10	—	—		#8-1 Str Dual #6 Str	75°C Cu
100	CF	3	600Vac	200kA	—	20	50	50	Spade Terminal**		75°C Cu

* 75°C or higher.
** Spade terminal, 30A max, insulated flange, wire size #12-10 for #8 stud.

Specifications

Agency Information

- CE Compliant
- RoHS Compliant
- UL 98 Listed, File E302370, Guide WHTY
- cULus to CSA Standard 22.2 No. 4-04, File 302370, Guide WHTY7

Terminals

- Single/dual conductor box lug or spade terminal suitable for line, load or accessory connection
- Torque: 0-60A: - #18-10 20Lb-In
- #8-4 35Lb-In
70-100A: - #18-10 Single 25Lb-In
- #8-2 Single 35Lb-In
- #1 Single 40Lb-In
- #6 Dual 45Lb-In

Fuses

- Uses finger-safe Class CF CUBEFuse™ with Class J performance
 - Low-Peak™ dual-element, time-delay*
 - Non-indicating 1-100A
 - Indicating 6-100A
 - Fast-Acting** 1-100A

* See Data Sheet # 9000

** See Data sheet # 2147

Storage and Operating Temperature

- -20°C to 75°C***

*** For fuse performance under or above 25°C, consult fuse performance derating charts in the Bussmann publication titled *Selecting Protective Devices (SPD)* reorder #3002.

Flammability Rating UL 94V0

Lockout/Tagout Provisions

- 4mm shank lock or standard pin-out devices

Data Sheet: 1157

Mounting

- 35mm DIN-Rail

Local Open Fuse Indication Minimum Voltage†

- 90Vac/115Vdc

† Circuit must be closed for indication light to illuminate.

Features

- Ampacity rejecting disconnects will not accept CUBEFuse amp ratings greater than switch rating
- IP20 Finger-safe construction with #10 or larger wire
- Switch interlock prohibits removing the fuse under load

Accessories

- Auxiliary contacts
- PLC Wired remote fuse indication (up to 60A)

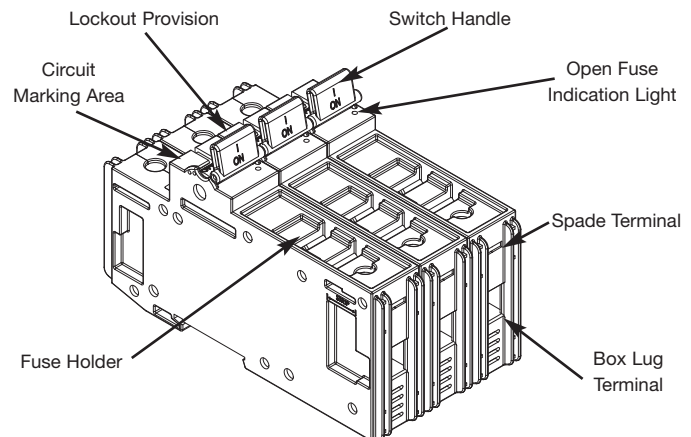

Compact Circuit Protector (CCP) Disconnect Switch—30, 60 & 100A 1-, 2- & 3-Pole, Class CF CUBEFuse™

Dimensions – mm (in)
30 and 60 Amp

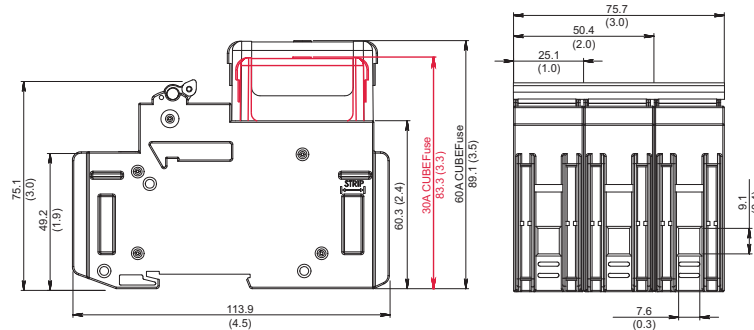

100 Amp

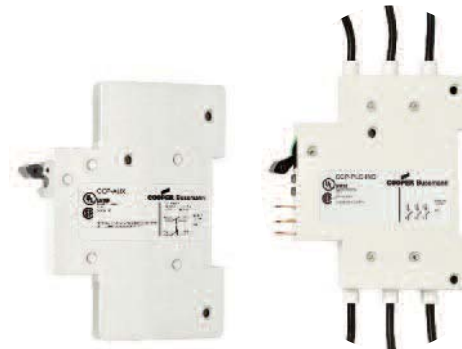
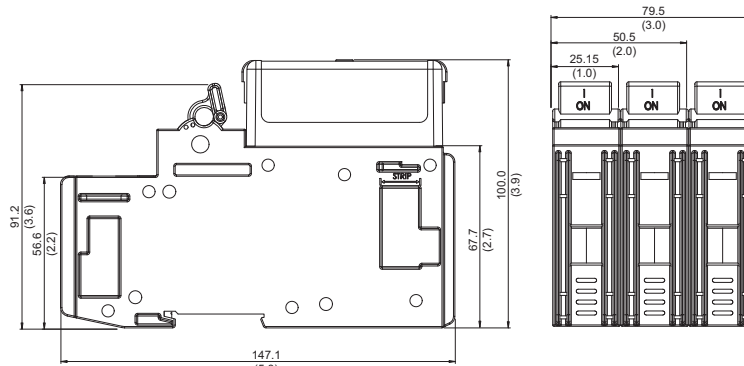

Auxiliary Contacts

PLC Indicator

(Includes leads with spade terminals)

CCP- _ _ CF Accessories					
Description	Configuration	Signal Output	Minimum Circuit Voltage	Agency Information	Part Number
Auxiliary Contacts NO+NC for Switch Status up to 60A	1 per CCP	5A/240Vac	–	UL 98 Recognized, cURus 22.2 No. 4-04, IEC 60947-5-1 AC15	CCP-AUX*
Auxiliary Contacts NO+NC for Switch Status 70 to 100A	1 per CCP	5A/240Vac	–	UL 98 Recognized, CSA C22.2 No. 4	CCP-AUX-100*
Wired Remote Fuse Indication for PLC Applications	1 per CCP	24Vdc	100Vac	UL 98 Recognized, cURus 22.2 No. 4-04	CCP-PLC-IND*
Wired Remote Fuse Indication for PLC Applications up to 60A	1 per CCP	8A/24Vdc	100Vac	UL 98 Recognized, CSA C22.2 No. 4	CCP-PLC-100*

* Refer to Data Sheet # 1157 for details.

Disconnect
Switches

Compact Circuit Protector Base (CCPB) CUBEFuse™



The revolutionary Bussmann CCPB with CUBEFuse™ is designed as a fused branch circuit disconnect with fuse holder for the Bussmann Quik-Spec™ Coordination Panelboard. The CCPB with CUBEFuse simplifies selective coordination and allows for isolation of individual branch circuit loads for safe work practices.

Product Features and Benefits

- Uses finger-safe Class CF Low-Peak™ CUBEFuse with current-limiting, time-delay Class J performance*
- High Short-Circuit Current Ratings at 200kA
- Disconnect rated to provide means for load isolation
- Full voltage rated at 600Vac
- UL 98 Listed and suitable for branch circuit disconnect and branch circuit protection
- 1-, 2- and 3-pole versions are horsepower rated
- Patented rejection feature helps prevent overfusing
- Complies with UL and cULus
- Open fuse indication light per pole
- Additional open fuse indication can be provided by using the indicating CUBEFuse version
- Built-in switch/fuse interlock prohibits removing the fuse while energized
- Permanent lockout/tagout provisions
- Lock-ON provision

*See data sheet 9000 for CUBEFuse specifications.

**For fuse performance under or above 25°C, consult fuse performance derating charts.

Specifications:

- CCPB Ampacity rejection breaks: 15A, 20A, 30A, 40A, 50A, 60A, 70A, 90A and 100A.
- 1-, 2- and 3-Pole versions
- For systems 600Vac (or less)
- Box lug loadside terminal:
 - 18-6AWG single & dual rated, solid or stranded – 75°C, Cu only
 - 4AWG single – 75°C, Cu only
- Box lug loadside terminal torque: 18-10AWG 20 Lb-In (2.2 N•m), 8-4AWG 35 Lb-In (3.9 N•m)
- Spade terminal load connection: Max. 30A suitable for use with #8-32UNC screw
- Bolt-on style bus connector, #10-32-UNC Hex flange Phillips screw, torque to 25 Lb-In (2.8N•m)
- Lockout/tagout: 4mm shank lock
- Bolt-mounted design into Quik-Spec Coordination Panelboard bus
- Local indication: illumination requires closed circuit and minimum 90Vac operating voltage
- RoHS compliant

Agency Information:

UL 98 Listed, File E302370, Guide WHTY
cULus to CSA Standard 22.2 No. 4, File E302370, Guide WHTY7
CE Compliant

Shipping Weight: 2.03 lbs per carton

Carton quantity: 6 poles

Environmental Data

Storage and operating temperature: -20°C to 75°C**

Compact Circuit Protector Base (CCPB) CUBEFuse™

Technical Ratings

CCPB Part Numbers	Poles	Voltage Rating	CUBEFuse™ (Class J performance)			Max. Fuse** Ampacity	SCCR	Hp Ratings***
			Time-Delay Non-Indicating	Time-Delay Indicating*	Fast-Acting Non-Indicating			
CCPB-1-15CF	1	600Vac	TCF1RN, TCF3RN, TCF6RN, TCF10RN, TCF15RN	TCF6, TCF10, TCF15	FCF1RN, FCF3RN, FCF6RN, FCF10RN, FCF15RN	15A	200kA	0.5Hp@120V
CCPB-2-15CF	2							1.5Hp@240V
CCPB-3-15CF	3							3Hp@240V 5Hp@480V 7.5Hp@600V
CCPB-1-20CF	1	600Vac	TCF17-1/2RN, TCF20RN	TCF17-1/2, TCF20	FCF20RN	20A	200kA	0.75Hp@120V
CCPB-2-20CF	2							2Hp@240V
CCPB-3-20CF	3							3Hp@240V 7.5Hp@480V 10Hp@600V
CCPB-1-30CF	1	600Vac	TCF25RN, TCF30RN	TCF25, TCF30	FCF25RN, FCF30RN	30A	200kA	1.5Hp@120V
CCPB-2-30CF	2							3Hp@240V
CCPB-3-30CF	3							5Hp@240V 15Hp@480V 10Hp@600V
CCPB-1-40CF	1	600Vac	TCF35RN, TCF40RN	TCF35, TCF40	FCF35RN, FCF40RN	40A	200kA	2.0Hp@120V
CCPB-2-40CF	2							3Hp@240V
CCPB-3-40CF	3							7.5Hp@240V 20Hp@480V 10Hp@600V
CCPB-1-50CF	1	600Vac	TCF45RN, TCF50RN	TCF45, TCF50	FCF45RN, FCF50RN	50A	200kA	3.0Hp@120V
CCPB-2-50CF	2							5Hp@240V
CCPB-3-50CF	3							7.5Hp@240V 20Hp@480V 10Hp@600V
CCPB-1-60CF	1	600Vac	TCF60RN	TCF60	FCF60RN	60A	200kA	3.0Hp@120V
CCPB-2-60CF	2							7.5Hp@240V
CCPB-3-60CF	3							7.5Hp@240V 20Hp@480V 10Hp@600V
CCPB-1-70CF	1	600Vac	TCF70RN	TCF70	FCF70RN	70A	200kA	3.0Hp@120V
CCPB-2-70CF	2							7.5Hp@240V
CCPB-3-70CF	3							15Hp@240V 30Hp@480V
CCPB-1-90CF	1	600Vac	TCF90RN	TCF90	FCF80RN, FCF90RN	90A	200kA	5.0Hp@120V
CCPB-2-90CF	2							10Hp@240V
CCPB-3-90CF	3							20Hp@240V 40Hp@480V
CCPB-1-100CF	1	600Vac	TCF100RN	TCF100	FCF100RN	100A	200kA	5.0Hp@120V
CCPB-2-100CF	2							10Hp@240V
CCPB-3-100CF	3							20Hp@240V 50Hp@480V

*1A and 3A indicating CUBEFuse not available. Correct fit with CCPB disconnect requires indicating CUBEFuse with date code R38 or later.

**Any fuse with an amp rating less than or equal to the max fuse rating may be used. Example: TCF15 may be used with CCPB-1-20CF.

***Do not use UPS/Critical Application fast-acting CF with motors.

Disconnect Switches

UL 98 Fused Rotary Disconnect Switches—30 to 800A

Description

Bussmann UL 98 and UL 489 fused disconnect switches “break” and “make” power circuits ON and OFF load.

The switches employ double break contacts per pole that help ensure complete isolation of the fuse when the switch is in the “OFF” position.

Features

- Make and break power under load
- Double break by pole
- DIN-Rail or panel mount (30-100A)
- Up to 200kA Short-Circuit Current Rating
- Finger-safe covers
- Compact footprints available
- Defeatable handles automatically re-latch when the panel door is closed
- Most disconnect switches are front, right side, flange or direct handle operable
- NFPA 79 Compliant handle kits

Agency Information

- UL 98, Guide WHTY, File E155130
- UL 489, Guide WJAZ, File E359801
- CSA 22.2 No. 4, File 257020
- Conforms with IEC 60947-3
- NFPA 79 (2002 Edition)

Online Resources

Visit www.cooperbussmann.com/Disconnects for:

- CAD Drawings
- Instruction Sheets
- UL Information







QuikShip Everyday Service ships the most common part numbers within 24 hours. Contact your Bussmann representative for details.

Available Bussmann Fuses

Class	Type	Data Sheet #
CC	LP-CC Time-Delay, Current Limiting	1023
CC	FNQ-R Time-Delay	1014
CC	KTK-R Fast-Acting	1015
J	LPJ Time-Delay, Current Limiting	1006 (0-60A)
J		1007 (70-600A)
J	With easyID™ open fuse indication	1062 (6-60A)
J		1063 (70-600A)
J	JKS Fast-Acting Fuses	1026 (0-60A)
J		1027 (70-600A)
J	DFJ High Speed Drive Fuse	1048 (0-600A)
L	KRP-C Time-Delay, Current Limiting	1008
L	KTU Fast-Acting	1010
L	KLU Time-Delay	1013

UL 98 Fused Rotary Disconnect Switches—30 to 800A

Specifications

					
	RDF30CC-3	RDF30J-3 / RDF60J-3-COMP	RDF60J-3	RDF200J-3	RDF600J-3
Part Number					
2-Pole	—	—	RDF30J-2	RDF60J-2-COMP	RDF60J-2
3-Pole	RDF30CC-3	RDF30J-3-COMP	RDF30J-3	RDF60J-3-COMP	RDF60J-3
3-Pole + Neutral	RDF30CC-3N	RDF30J-3N-COMP	—	—	—
4-Pole	—	—	RDF30J-4	RDF60J-4-COMP	RDF60J-4
UL Standard	UL 489	UL 489	UL 98	UL 98	UL 98
Fuse Class	CC	J	J	J	J
Max Fuse/Ampacity	30	30	30	60	60
Switch Type	Compact	Compact	Standard	Compact	Standard
Handle Operation	Front	Front	Front/Side Flange	Front/Side Flange	Front/Side Flange
UL Electrical Ratings					
Max AC Volts	600Vac	600Vac	600Vac	600Vac	600Vac
Max DC Volts*	—	—	250Vdc	250Vdc	250Vdc
Std AC Horsepower Ratings					
1-Phase, 240Vac	—	—	3	10	10
3-Phase, 240Vac	3	3	3	7.5	15
3-Phase, 480Vac	5.0	5.0	5.0	15	25
3-Phase, 600Vac	7.5	7.5	7.5	15	30
Max AC Horsepower Ratings					
3-Phase, 240Vac	7.5	7.5	7.5	15	30
3-Phase, 480Vac	15	15	15	30	60
3-Phase, 600Vac	20	20	20	50	75
DC Horsepower Ratings					
125Vdc	—	—	3	5	7.5
250Vdc	—	—	5	10	20
Electrical Characteristics					
SCCR	100kA	100kA	200kA	100kA	200kA
Terminal Lugs/Kits	Integral	Integral	Integral	Integral	Integral
Mounting Torque - Lb-In (N·m)	—	—	—	—	160 (18)
Wire Type	75°C Cu	75°C Cu	75°C Cu	75°C Cu	75°C Cu/Al
Wire Range & Torque - Lb-In (N·m)					
Solid	#14-10 27 (3.1)	#14-10 27 (3.1)	#14-10 31 (3.5)	#14-10 31 (3.5)	#12-10 35.4 (4)
Stranded	#14-10 27 (3.1)	#14-10 27 (3.1)	#14-6 31 (3.5)	#14-6 31 (3.5)	#12-1 35.4 (4)
					#6-300MCM 275 (31)
					#4-600MCM 550 (62)
					Dual 1/0-250MCM 550 (62)
					(2) #2-600MCM 375 (42.4)
					(2) #2-600MCM 375 (42.4)
Mechanical Characteristics					
Endurances/Cycles	10,000	10,000	10,000	10,000	10,000
Physical Characteristics					
Dimensions					
See drawings on product pages					
Weight - Lbs (KG)					
2-Pole	—	—	3.0 (1.3)	3.1 (1.4)	4.0 (1.8)
3-Pole	1.3 (0.6)	1.4 (0.6)	3.8 (1.7)	4.1 (1.8)	5.3 (2.4)
3-Pole + Neutral	1.4 (0.6)	1.5 (0.7)	—	—	—
4-Pole	—	—	4.7 (2.1)	4.8 (2.2)	X.X (2.9)
Environmental					
Operating Temp. Range	-20°C to 70°C	-20°C to 70°C	-20°C to 70°C	-20°C to 70°C	-20°C to 70°C
Flammability Rating	UL 94-V0	UL 94-V0	UL 94-V0	UL 94-V0	UL 94-V0
Accessories					
Lug Kit	Integral	Integral	Integral	Integral	Integral
Handles					
Direct	•	•	•	•	•
Front Selector	•	•	—	—	—
Front Pistol	•	•	•	•	•
Side Pistol	—	—	•	•	•
Flange					
Cable	—	—	•	•	•
Shaft	—	—	•	•	•
NFPA Through Door Handle	•	•	•	•	•
Shafts c/s - mm	5x5	5x5	10x10	10x10	10x10
Terminal Shrouds	Not Required	Not Required	Not Required	Not Required	Not Required
Auxiliary Contacts					
(1) NO	•	•	•	•	•
(1) NC	•	•	•	•	•
AC Ratings					
Volts	600	600	600	600	600
Amps	10	10	10	10	10

Disconnect
Switches

• Available, see product page for details and part numbers.
 — Not available.
 * General purpose only, not photovoltaic rated.

UL 98 Fused Rotary Disconnect Switches—30A

Compact Class CC & Class J

For a Complete Assembly, Please Select:

SWITCH		Switch									
		Amp Rating	Fuse Class	Number of Poles	SCCR	Max Horsepower Rating, 3-Ph			Wire Size	Wire Type	Part Number
		30	CC	3	100kA	220/240Vac	440/480Vac	600 Vac	#14-10 Sol/Str	75°C Cu	RDF30CC-3
		30	CC	3 + Ntrl*	100kA	7.5	15	20	#14-10 Sol/Str	75°C Cu	RDF30CC-3N
		30	J	3	100kA	7.5	15	20	#14-10 Sol/Str	75°C Cu	RDF30J-3-COMP
		30	J	3 + Ntrl*	100kA	7.5	15	20	#14-10 Sol/Str	75°C Cu	RDF30J-3N-COMP
		* Neutral is switched.									
+											
HANDLE		Direct Mount Handle - mounts directly to switch, no shaft required									
		For Switch Part Number	Color	Test Function	Padlockable					Part Number	
		RDF30CC- RDF30J-_-COMP	Black Black	Y Y	Y Y					DIR-05 DIR-06	
OR											
SELECT FOR STANDARD APPLICATIONS		External Front Operated Selector Handle - shaft required									
		NEMA Type	Color	Test Function	Padlockable	Defeatable				Part Number	
		1, 3R, 4, 4X, 12	Black	N	Y	Y				H4X-04B	
		1, 3R, 4, 4X, 12	Red/Yellow	N	Y	Y				H4X-04R	
		Shafts for Selector Handles									
		Length in (mm)	Mounting Depth (X) in (mm)							Part Number	
		7.9 (200)	4.02~9.65 (102~245)							SH1-200	
		12.6 (320)	4.02~14.37 (102~365)							SH1-320	
		15.7 (400)	4.02~17.52 (102~445)							SH1-400	
OR											
HANDLE		External Front Operated Pistol Handles - shaft required									
		NEMA Type	Color	Test Function	Padlockable	Defeatable				Part Number	
		1, 3R, 12	Black	N	Y	Y				H12-05B	
		1, 3R, 12	Red/Yellow	N	Y	Y				H12-05R	
		1, 3R, 4, 4X, 12	Black	N	Y	Y				H4X-05B	
		1, 3R, 4, 4X, 12	Red/Yellow	N	Y	Y				H4X-05R	
		1, 3R, 4, 4X, 12	Black	Y	Y	Y				H4X-05TB	
		1, 3R, 4, 4X, 12	Red/Yellow	Y	Y	Y				H4X-05TR	
		Metallic Hasp (Heavy Duty) External Front Operated Pistol Handles - shaft required									
		NEMA Type	Color	Test Function	Padlockable	Defeatable				Part Number	
		1, 3R, 4, 4X, 12	Black	N	Y	Y				H4X-05BHD	
		1, 3R, 4, 4X, 12	Red/Yellow	N	Y	Y				H4X-05RHD	
		Shafts for Pistol Handles									
		Length in (mm)	Mounting Depth (X) in (mm)							Part Number	
		7.9 (200)	4.02~9.65 (102~245)							SH2-200	
		12.6 (320)	4.02~14.37 (102~365)							SH2-320	
		15.7 (400)	4.02~17.52 (102~445)							SH2-400	
OR											
		NFPA Through the Door Handle Kit - to be used with selector handle or front pistol handle									
		Color	Test Function	Padlockable	Defeatable					Part Number	
		Red	N	Y	N					H79-1	
and...											
ACCESSORIES		Auxiliary Contacts									
		Contact Type	Number of Contacts	Continuous Amp Rating	Voltage Rating	Maximum Number of Auxiliary Contacts per Disconnect Switch Part Number				Part Number	
		NO	1	10A	600Vac	RDF30CC-_: 4 / 8 with BAC-HOLDER2				BAC05 ⁽¹⁾	
		NC	1	10A	600Vac	RDF30J-_-COMP: 2 / 6 with BAC-HOLDER2				BAC06 ⁽¹⁾	
		Auxiliary Contact Holder				Accepts 4 Auxiliary Contacts: BAC05 or BAC06				BAC-HOLDER2 ⁽²⁾	

UL 98 Fused Rotary Disconnect Switches—30A

Compact Class CC & Class J

Dimensions – in (mm)

- RDF30CC-

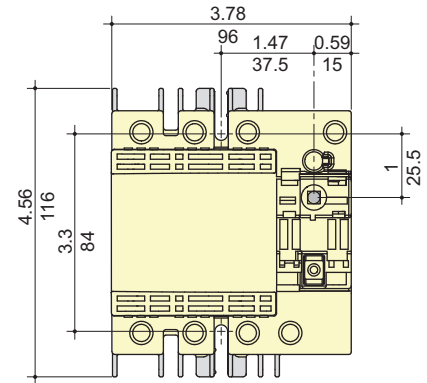
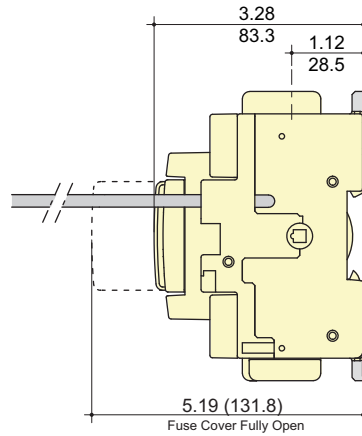

- RDF30J- -COMP

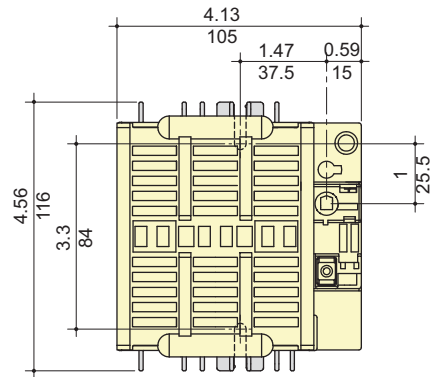
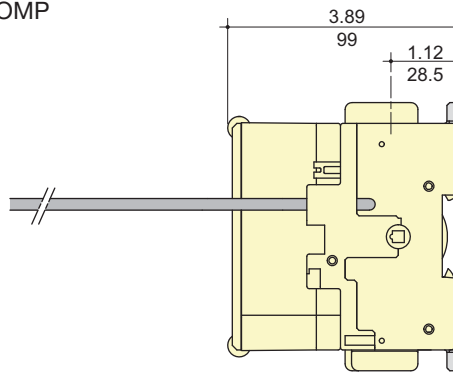

Disconnect
Switches

External Front Selector Handle

Selector Handle Type

Direction of Front Operation

Door Drilling Layout

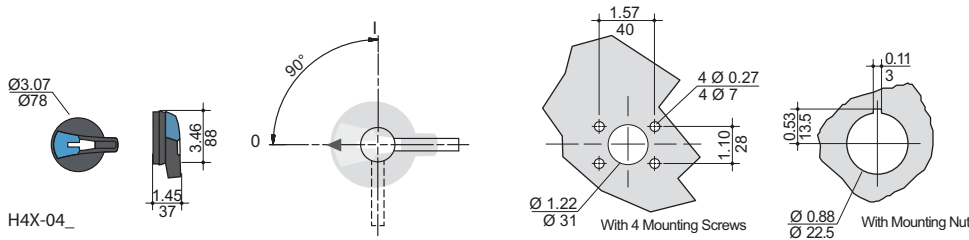

External Front Pistol Handles

Pistol Handle Type

Direction of Front Operation

Door Drilling Layout

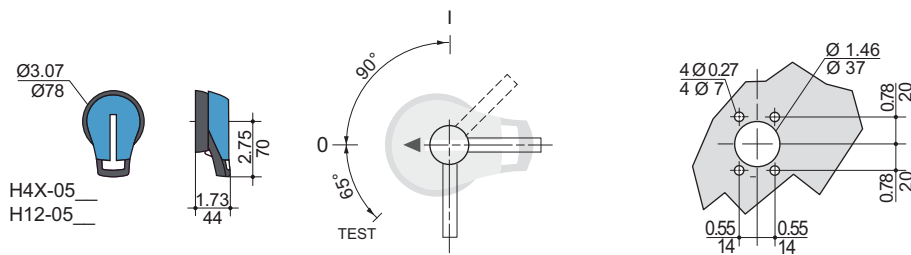

UL 98 Fused Rotary Disconnect Switches—30A

Standard Class J

For a Complete Assembly, Please Select:

SWITCH		Switch												
		Amp Rating	Fuse Class	No. of Poles	SCCR	Max Horsepower Rating					Wire Size	Wire Type	Part Number	
						1-Phase 220/240Vac	3-Phase 220/240Vac	440/480Vac	600 Vac	DC*				
										125 Vdc	250 Vdc			
		30	J	2	200kA	3	-	-	-	3	5	#14-10 Sol #14-6 Str	75°C Cu	RDF30J-2
		30	J	3	200kA	-	7.5	15	20	3	5	#14-10 Sol #14-6 Str	75°C Cu	RDF30J-3
		30	J	4	200kA	-	7.5	15	20	3	5	#14-10 Sol #14-6 Str	75°C Cu	RDF30J-4
		* DC Ratings use two poles in series.												
		+												
	HANDLE		Direct Mount Handle - mounts directly to switch, no shaft required											
		For Switch Part Number	Color	Test Function	Padlockable							Part Number		
		All Switches	Black	Y	Y - On Switch							DIR-07		
		or												
		External Front Operated Pistol Handles - shaft required												
		NEMA Type	Color	Test Function	Padlockable	Defeatable						Part Number		
		1, 3R, 12	Black	N	Y	Y						H12-05B		
		1, 3R, 12	Red/Yellow	N	Y	Y						H12-05R		
		1, 3R, 4, 4X, 12	Black	N	Y	Y						H4X-05B		
		1, 3R, 4, 4X, 12	Red/Yellow	N	Y	Y						H4X-05R		
or	1, 3R, 4, 4X, 12	Black	Y	Y	Y						H4X-05TB			
	1, 3R, 4, 4X, 12	Red/Yellow	Y	Y	Y						H4X-05TR			
	Metallic Hasp (Heavy Duty) External Front Operated Pistol Handles - shaft required													
	NEMA Type	Color	Test Function	Padlockable	Defeatable						Part Number			
	1, 3R, 4, 4X, 12	Black	N	Y	Y						H4X-05BHD			
	1, 3R, 4, 4X, 12	Red/Yellow	N	Y	Y						H4X-05RHD			
	External Right Side Operated Pistol Handles - shaft required													
	NEMA Type	Color	Test Function	Padlockable	Defeatable						Part Number			
	1, 3R, 4, 4X, 12	Black	N	Y	N/A						H4X-05SB			
	1, 3R, 4, 4X, 12	Red/Yellow	N	Y	N/A						H4X-05SR			
	Shafts for Pistol Handles													
	Length in (mm)	Mounting Depth (X) in (mm)								Part Number				
	7.9 (200)	5.30~9.06 (135~230)								SH5-200				
	12.6 (320)	5.30~13.78 (135~350)								SH5-320				
	15.7 (400)	5.30~16.93 (135~430)								SH5-400				
	or													
	Flange Handle⁽¹⁾ - requires shaft operated mechanism or cable operated mechanism + cable													
	NEMA Type	Flange Style	Test Function	Padlockable	Defeatable						Part Number			
	1, 3R, 4, 12	Standard	N	Y	Y						FLH1			
	1, 3R, 4, 4X, 12	Chrome Plated	N	Y	Y						FLH2			
	Shaft Operated Flange Mechanism⁽²⁾ - includes shaft													
	For Enclosure Depth - in (mm)										Part Number			
	6~24 (152~613)										FLRM			
	Cable Operated Flange Mechanism and Cable - must select Mechanism⁽³⁾ and Cable⁽⁴⁾													
	Item / Length										Part Number			
	Cable Mechanism										FLCM			
	36" (900mm) Cable										FLC36			
	60" (1500mm) Cable										FLC60			
	120" (3000mm) Cable										FLC120			
	or													
	NFPA Through the Door Handle Kit - to be used with selector handle or front pistol handle													
	Color	Test Function	Padlockable	Defeatable							Part Number			
	Red	N	Y	N							H79-2			

UL 98 Fused Rotary Disconnect Switches—30A Standard Class J

and ...

ACC. AUX CONTACTS		Auxiliary Contacts				Max Number of Aux Contacts per Switch	Part Number
		Contact Type	Number of Contacts	Continuous Amp Rating	Voltage Rating		
		NO	1	10A	600Vac	4	BAC05
		NC	1	10A	600Vac	4	BAC06

Dimensions – in (mm)

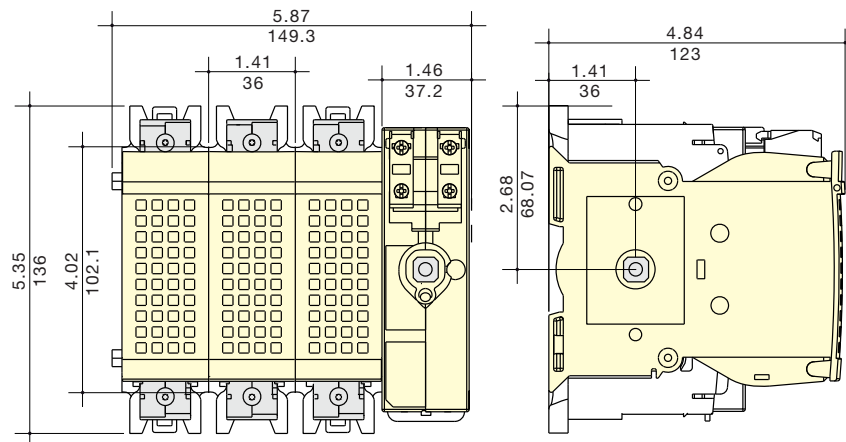

Direct Mount Handle

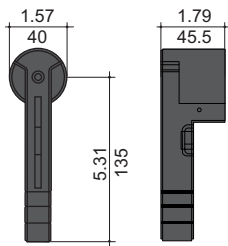

DIR-07

Flange Handle

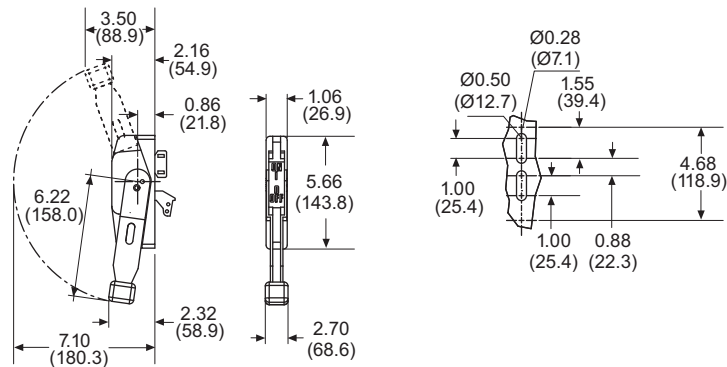

FLH_

External Front & Right Side Pistol Handle

Handle Type

Direction of Front Operation

Direction of Right Side Operation

Door Drilling Layout

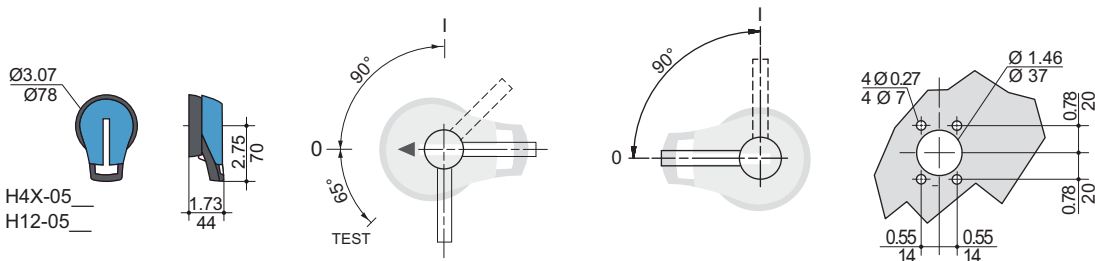

H4X-05
H12-05

UL 98 Fused Rotary Disconnect Switches—60A

Compact Class J

For a Complete Assembly, Please Select:

SWITCH		Switch												
		Amp Rating	Fuse Class	Number of Poles	SCCR	Max Horsepower Rating						Wire Size	Wire Type	Part Number
						1-Phase 220/240Vac	3-Phase 220/240Vac	440/480Vac	600 Vac	DC*				
		60	J	2	100kA	10	-	-	-	5	10	#14-10 Sol #14-6 Str	75°C Cu	RDF60J-2-COMP
60	J	3	100kA	-	15	30	50	5	10	#14-10 Sol #14-6 Str	75°C Cu	RDF60J-3-COMP		
60	J	4	100kA	-	15	30	50	5	10	#14-10 Sol #14-6 Str	75°C Cu	RDF60J-4-COMP		
* DC Ratings use two poles in series.														
+														
SELECT FOR STANDARD APPLICATIONS		Direct Mount Handle - mounts directly to switch, no shaft required												
		For Switch Part Number	Color	Test Function	Padlockable							Part Number		
		All Switches	Black	Y	Y - On Switch							DIR-07		
		or												
			External Front Operated Pistol Handles - shaft required											
			NEMA Type	Color	Test Function	Padlockable	Defeatable							Part Number
			1, 3R, 12	Black	N	Y	Y							H12-05B
			1, 3R, 12	Red/Yellow	N	Y	Y							H12-05R
			1, 3R, 4, 4X, 12	Black	N	Y	Y							H4X-05B
			1, 3R, 4, 4X, 12	Red/Yellow	N	Y	Y							H4X-05R
1, 3R, 4, 4X, 12	Black		Y	Y	Y							H4X-05TB		
1, 3R, 4, 4X, 12	Red/Yellow		Y	Y	Y							H4X-05TR		
	Metallic Hasp (Heavy Duty) External Front Operated Pistol Handles - shaft required													
	NEMA Type		Color	Test Function	Padlockable	Defeatable							Part Number	
	1, 3R, 4, 4X, 12	Black	N	Y	Y							H4X-05BHD		
	1, 3R, 4, 4X, 12	Red/Yellow	N	Y	Y							H4X-05RHD		
		External Right Side Operated Pistol Handles - shaft required												
		NEMA Type	Color	Test Function	Padlockable	Defeatable							Part Number	
		1, 3R, 4, 4X, 12	Black	N	Y	N/A							H4X-05SB	
		1, 3R, 4, 4X, 12	Red/Yellow	N	Y	N/A							H4X-05SR	
			Shafts for Pistol Handles											
			Length in (mm)	Mounting Depth (X) in (mm)							Part Number			
7.9 (200)			5.30~9.06 (135~230)							SH5-200				
12.6 (320)			5.30~13.78 (135~350)							SH5-320				
15.7 (400)		5.30~16.93 (135~430)							SH5-400					
or														
	Flange Handle⁽¹⁾ - requires shaft operated mechanism or cable operated mechanism + cable													
	NEMA Type	Flange Style	Test Function	Padlockable	Defeatable							Part Number		
	1, 3R, 4, 12	Standard	N	Y	Y							FLH1		
	1, 3R, 4, 4X, 12	Chrome Plated	N	Y	Y							FLH2		
		Shaft Operated Flange Mechanism⁽²⁾ - includes shaft												
		For Enclosure Depth - in (mm)										Part Number		
		6-24 (152~613)										FLRM		
		Cable Operated Flange Mechanism and Cable - must select Mechanism⁽³⁾ and Cable⁽⁴⁾												
		Item / Length										Part Number		
		Cable Mechanism										FLCM		
36" (900mm) Cable											FLC36			
60" (1500mm) Cable											FLC60			
120" (3000mm) Cable										FLC120				
or														
	NFPA Through the Door Handle Kit - to be used with selector handle or front pistol handle													
	Color	Test Function	Padlockable	Defeatable								Part Number		
Red	N	Y	N								H79-2			

UL 98 Fused Rotary Disconnect Switches—60A

Compact Class J

		and ...					
Acc.	AUX CONTACTS	Auxillary Contacts				Part Number	
		Contact Type	Number of Contacts	Continuous Amp Rating	Voltage Rating		
		NO	1	10A	600Vac		4
		NC	1	10A	600Vac	4	BAC06

Dimensions – in (mm)

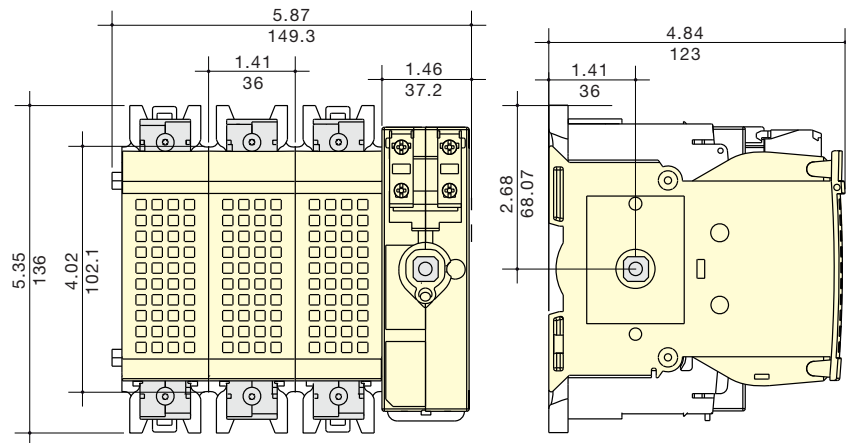

Direct Mount Handle

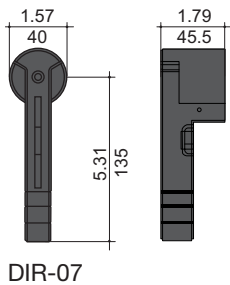

Flange Handle

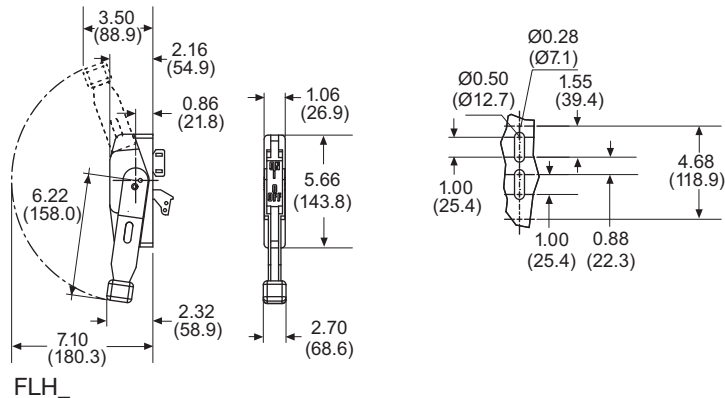

External Front & Right Side Pistol Handle

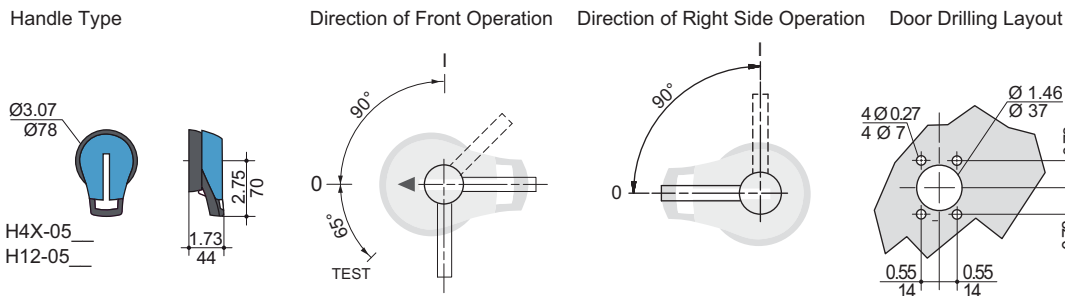





Disconnect
Switches

UL 98 Fused Rotary Disconnect Switches—60A

Standard Class J

For a Complete Assembly, Please Select:

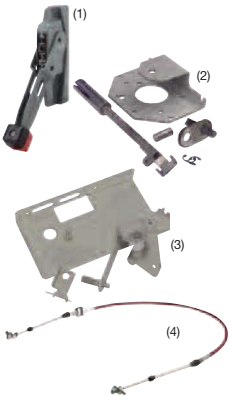
SWITCH		Switch												
		Amp Rating	Fuse Class	Number of Poles	SCCR	Max Horsepower Rating						Wire Size	Wire Type	Part Number
						1-Phase 220/240Vac	3-Phase 220/240Vac	440/480Vac	600 Vac	DC*				
		60	J	2	200kA	10	-	-	-	5	10	#12-10 Sol #12-1 Str	75°C Cu	RDF60J-2
60	J	3	200kA	-	15	30	50	5	10	#12-10 Sol #12-1 Str	75°C Cu	RDF60J-3		
60	J	4	200kA	-	15	30	50	5	10	#12-10 Sol #12-1 Str	75°C Cu	RDF60J-4		
* DC Ratings use two poles in series.														
+														
HANDLE		Direct Mount Handle - mounts directly to switch, no shaft required												
		For Switch Part Number	Color	Test Function	Padlockable							Part Number		
		All Switches	Black	Y	Y							DIR-07		
OR														
Select for Standard Applications	 or 	External Front Operated Pistol Handles - shaft required												
		NEMA Type	Color	Test Function	Padlockable	Defeatable							Part Number	
		1, 3R, 12	Black	N	Y	Y							H12-03B	
		1, 3R, 12	Red/Yellow	N	Y	Y							H12-03R	
		1, 3R, 4, 4X, 12	Black	N	Y	Y							H4X-06B	
		1, 3R, 4, 4X, 12	Red/Yellow	N	Y	Y							H4X-06R	
		1, 3R, 4, 4X, 12	Black	Y	Y	Y							H4X-06TB	
		1, 3R, 4, 4X, 12	Red/Yellow	Y	Y	Y							H4X-06TR	
		Metallic Hasp (Heavy Duty) External Front Operated Pistol Handles - shaft required												
		NEMA Type	Color	Test Function	Padlockable	Defeatable							Part Number	
		1, 3R, 4, 4X, 12	Black	N	Y	Y							H4X-06BHD	
		1, 3R, 4, 4X, 12	Red/Yellow	N	Y	Y							H4X-06RHD	
External Right Side Operated Pistol Handles - shaft required														
NEMA Type	Color	Test Function	Padlockable	Defeatable							Part Number			
1, 3R, 4, 4X, 12	Black	N	Y	N/A							H4X-06SB			
1, 3R, 4, 4X, 12	Red/Yellow	N	Y	N/A							H4X-06SR			
Shafts for Pistol Handles														
Length in (mm)	Mounting Depth (X) in (mm)										Part Number			
7.9 (200)	5.30~9.06 (135~230)										SH5-200			
12.6 (320)	5.30~13.78 (135~350)										SH5-320			
15.7 (400)	5.30~16.93 (135~430)										SH5-400			
OR														
	Flange Handle⁽¹⁾ - requires shaft operated mechanism or cable operated mechanism + cable													
	NEMA Type	Flange Style	Test Function	Padlockable	Defeatable							Part Number		
	1, 3R, 4, 12	Standard	N	Y	Y							FLH1		
	1, 3R, 4, 4X, 12	Chrome Plated	N	Y	Y							FLH2		
	Shaft Operated Flange Mechanism⁽²⁾ - includes shaft													
	For Enclosure Depth in (mm)											Part Number		
	6~24 (152~613)											FLRM		
	Cable Operated Flange Mechanism and Cable - must select Mechanism⁽³⁾ and Cable⁽⁴⁾													
	Item / Length											Part Number		
	Cable Mechanism											FLCM		
36" (900mm) Cable											FLC36			
60" (1500mm) Cable											FLC60			
120" (3000mm) Cable											FLC120			

UL 98 Fused Rotary Disconnect Switches—60A

Standard Class J

Select		or					
NFPA HANDLE		NFPA Through the Door Handle Kit - to be used with front pistol handle					
		Color		Test Function	Padlockable	Defeatable	Part Number
		Red		N	Y	N	H79-2
Acc.		and ...					
AUX CONTACTS		Auxiliary Contacts					
		Contact Type	Number of Contacts	Continuous Amp Rating	Voltage Rating	Max Number of Aux Contacts per Switch	Part Number
		NO	1	10A	600Vac	4	BAC05
		NC	1	10A	600Vac	4	BAC06

Dimensions – in (mm)

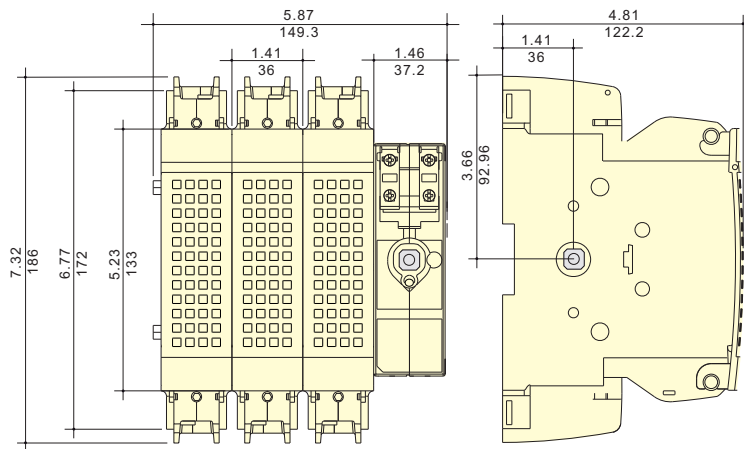

Direct Mount Handle

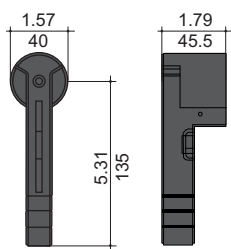

DIR-07

Flange Handle

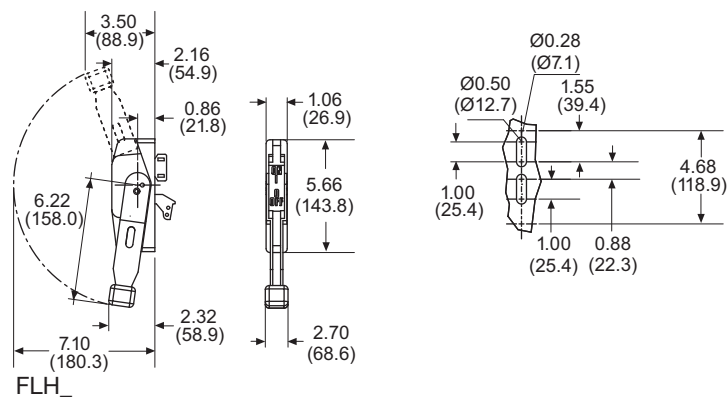

FLH_

External Front and Right Side Pistol Handle

Handle Type Direction of Front Operation Direction of Right Side Operation Door Drilling Layout

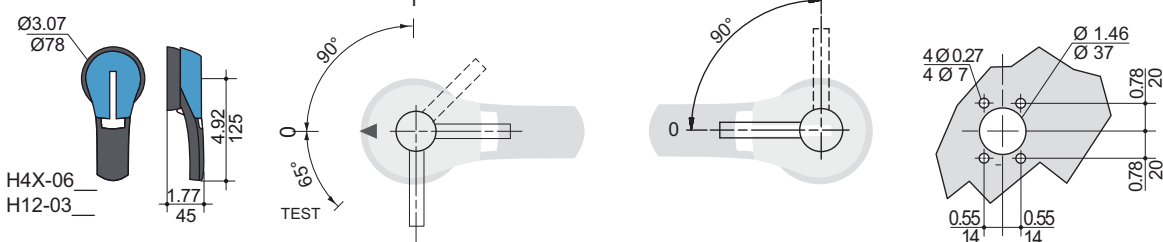







H4X-06
H12-03

Disconnect Switches



UL 98 Fused Rotary Disconnect Switches—100A

Standard Class J

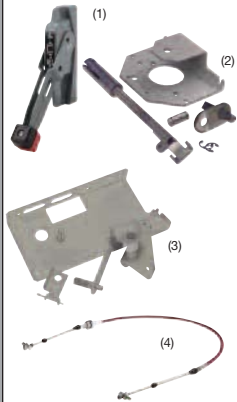
For a Complete Assembly, Please Select:

SWITCH		Switch												
		Max Horsepower Rating												
		Amp Rating	Fuse Class	Number of Poles	SCCR	1-Phase 220/240Vac	3-Phase 220/240Vac	440/480Vac	600 Vac	DC* 125 Vdc	250 Vdc	Wire Size	Wire Type	Part Number
		100	J	2	200kA	10	-	-	-	7.5	20	#12-10 Sol #12-1 Str	75°C Cu	RDF100J-2
100	J	3	200kA	-	30	60	75	7.5	20	#12-10 Sol #12-1 Str	75°C Cu	RDF100J-3		
100	J	4	200kA	-	30	60	75	7.5	20	#12-10 Sol #12-1 Str	75°C Cu	RDF100J-4		
* DC Ratings use two poles in series.														
+														
HANDLE		Direct Mount Handle - mounts directly to switch, no shaft required												
		For Switch Part Number	Color	Test Function	Padlockable								Part Number	
		All Switches	Black	Y	Y								DIR-07	
or														
Select for Standard Applications	 or  +  + 	External Front Operated Pistol Handles - shaft required												
		NEMA Type	Color	Test Function	Padlockable	Defeatable							Part Number	
		1, 3R, 12	Black	N	Y	Y							H12-03B	
		1, 3R, 12	Red/Yellow	N	Y	Y							H12-03R	
		1, 3R, 4, 4X, 12	Black	N	Y	Y							H4X-06B	
		1, 3R, 4, 4X, 12	Red/Yellow	N	Y	Y							H4X-06R	
		1, 3R, 4, 4X, 12	Black	Y	Y	Y							H4X-06TB	
		1, 3R, 4, 4X, 12	Red/Yellow	Y	Y	Y							H4X-06TR	
		Metallic Hasp (Heavy Duty) External Front Operated Pistol Handles - shaft required												
		NEMA Type	Color	Test Function	Padlockable	Defeatable							Part Number	
		1, 3R, 4, 4X, 12	Black	N	Y	Y							H4X-06BHD	
		1, 3R, 4, 4X, 12	Red/Yellow	N	Y	Y							H4X-06RHD	
		External Right Side Operated Pistol Handles - shaft required												
		NEMA Type	Color	Test Function	Padlockable	Defeatable							Part Number	
		1, 3R, 4, 4X, 12	Black	N	Y	N/A							H4X-06SB	
1, 3R, 4, 4X, 12	Red/Yellow	N	Y	N/A							H4X-06SR			
Shafts for Pistol Handles														
Length in (mm)	Mounting Depth (X) in (mm)									Part Number				
7.9 (200)	5.30~9.06 (135~230)									SH5-200				
12.6 (320)	5.30~13.78 (135~350)									SH5-320				
15.7 (400)	5.30~16.93 (135~430)									SH5-400				
or														
	Flange Handle⁽¹⁾ - requires shaft operated mechanism or cable operated mechanism + cable													
	NEMA Type	Flange Style	Test Function	Padlockable	Defeatable							Part Number		
	1, 3R, 4, 12	Standard	N	Y	Y							FLH1		
	1, 3R, 4, 4X, 12	Chrome Plated	N	Y	Y							FLH2		
	Shaft Operated Flange Mechanism⁽²⁾ - includes shaft													
	For Enclosure Depth in (mm)										Part Number			
	6~24 (152~613)										FLRM			
	Cable Operated Flange Mechanism and Cable - must select Mechanism⁽³⁾ and Cable⁽⁴⁾													
	Item / Length										Part Number			
	Cable Mechanism										FLCM			
36" (900mm) Cable										FLC36				
60" (1500mm) Cable										FLC60				
120" (3000mm) Cable										FLC120				

UL 98 Fused Rotary Disconnect Switches—100A Standard Class J

or						
Select	NFPA HANDLE	NFPA Through the Door Handle Kit - to be used with front pistol handle				
		Color	Test Function	Padlockable	Defeatable	Part Number
		Red	N	Y	N	H79-2
and ...						
Acc.	AUX CONTACTS	Auxiliary Contacts				Part Number
		Contact Type	Number of Contacts	Continuous Amp Rating	Voltage Rating	Max Number of Aux Contacts per Switch
			NO	1	10A	600Vac
		NC	1	10A	600Vac	4
						BAC05
						BAC06

Dimensions – in (mm)

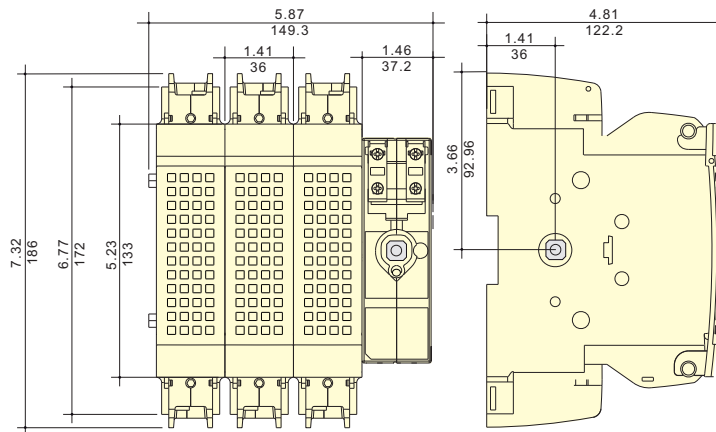

Direct Mount Handle

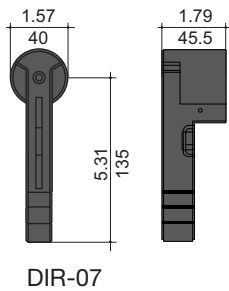

Flange Handle

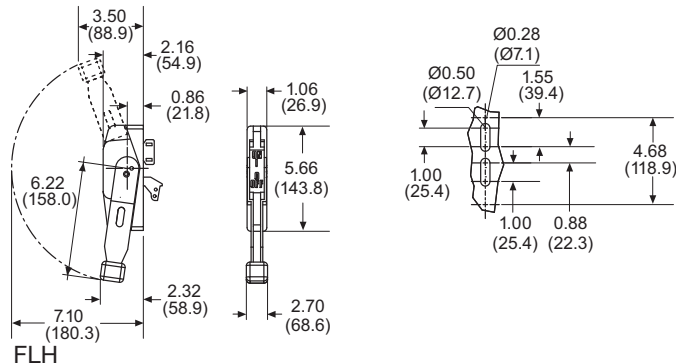

External Front & Right Side Pistol Handle

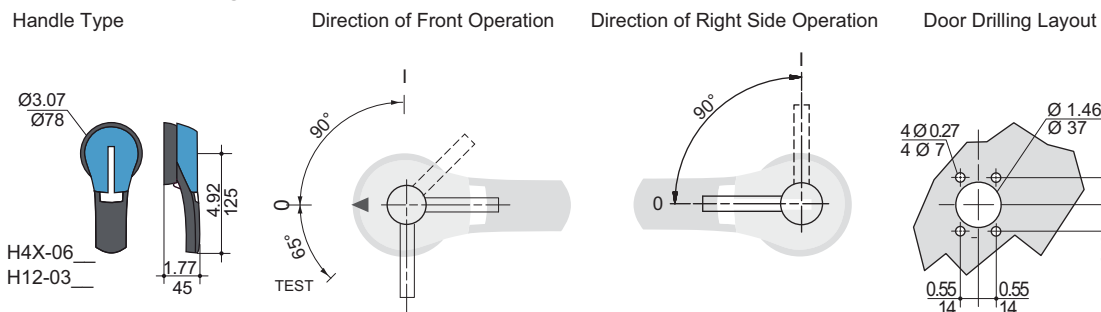





Disconnect Switches

UL 98 Fused Rotary Disconnect Switches—200 & 400A Standard Class J

For a Complete Assembly, Please Select:

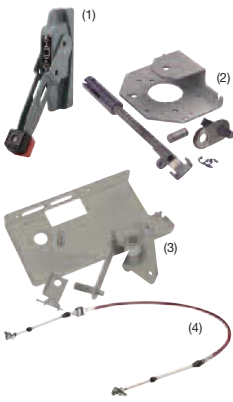
SWITCH + LUGS	 + 	Switch										
		Amp Rating	Fuse Class	Number of Poles	SCCR	Max Horsepower Rating				DC*		Part Number
						1-Phase 220/240Vac	220/240Vac	3-Phase 440/480Vac	600 Vac	125 Vdc	250 Vdc	
		200	J	2	200kA	10	-	-	-	-	-	RDF200J-2
		200	J	3	200kA	-	60	125	150	-	-	RDF200J-3
		200	J	4	200kA	-	60	125	150	-	-	RDF200J-4
		400	J	2	200kA	10	-	-	-	20	50	RDF400J-2
		400	J	3	200kA	-	125	250	350	20	50	RDF400J-3
		400	J	4	200kA	-	125	250	350	20	50	RDF400J-4
		* DC Ratings use two poles in series.										
Terminal Lug Kit												
Switch Amp Rating	Number of Poles	Lugs Per Kit	Wire Range			Wire Type		Part Number				
200	2	2	#6-300MCM			75°C Cu/Al		LUG1-2				
200	3	3	#6-300MCM			75°C Cu/Al		LUG1-3				
200	4	4	#6-300MCM			75°C Cu/Al		LUG1-4				
400	2	2	#4-600MCM or Dual 1/0-250MCM			75°C Cu/Al		LUG2-2				
400	3	3	#4-600MCM or Dual 1/0-250MCM			75°C Cu/Al		LUG2-3				
400	4	4	#4-600MCM or Dual 1/0-250MCM			75°C Cu/Al		LUG2-4				
+												
	Direct Mount Handle - mounts directly to switch, no shaft required											
	For Switch Part Number	Color	Test Function	Padlockable						Part Number		
	All Switches	Black	Y	Y						DIR-07		
OR												
HANDLE	 or  + 	External Front Operated Pistol Handles - shaft required										
		NEMA Type	Color	Test Function	Padlockable	Defeatable					Part Number	
		1, 3R, 12	Black	N	Y	Y					H12-03B	
		1, 3R, 12	Red/Yellow	N	Y	Y					H12-03R	
		1, 3R, 4, 4X, 12	Black	N	Y	Y					H4X-06B	
		1, 3R, 4, 4X, 12	Red/Yellow	N	Y	Y					H4X-06R	
		1, 3R, 4, 4X, 12	Black	Y	Y	Y					H4X-06TB	
		1, 3R, 4, 4X, 12	Red/Yellow	Y	Y	Y					H4X-06TR	
		Metallic Hasp (Heavy Duty) External Front Operated Pistol Handles - shaft required										
		NEMA Type	Color	Test Function	Padlockable	Defeatable					Part Number	
1, 3R, 4, 4X, 12	Black	N	Y	Y					H4X-06BHD			
1, 3R, 4, 4X, 12	Red/Yellow	N	Y	Y					H4X-06RHD			
External Right Side Operated Pistol Handles - shaft required												
NEMA Type	Color	Test Function	Padlockable	Defeatable					Part Number			
1, 3R, 4, 4X, 12	Black	N	Y	N/A					H4X-06SB			
1, 3R, 4, 4X, 12	Red/Yellow	N	Y	N/A					H4X-06SR			
Shafts for Pistol Handles												
Length in (mm)	Mounting Depth (X) in (mm)								Part Number			
7.9 (200)	200A: 5.70-9.06 (145-230) 400A: 7.87-10.24 (200-260)								SH5-200			
12.6 (320)	200A: 5.70-13.78 (145-350) 400A: 7.87-16.93 (200-380)								SH5-320			
15.7 (400)	200A: 5.70-16.93 (145-430) 400A: 7.87-18.10 (200-460)								SH5-400			

UL 98 Fused Rotary Disconnect Switches—200 & 400A Standard Class J

Select for Standard Applications		OR					
			Flange Handle⁽¹⁾ 200A Only - requires shaft operated mechanism <i>or</i> cable operated mechanism + cable				
NEMA Type	Flange Style		Test Function	Padlockable	Defeatable	Part Number	
1, 3R, 4, 12	Standard		N	Y	Y	FLH1	
1, 3R, 4, 4X, 12	Chrome Plated		N	Y	Y	FLH2	
Shaft Operated Flange Mechanism⁽²⁾ 200A Only - includes shaft							
For Enclosure Depth in (mm)						Part Number	
6-24 (152-613)						FLRM	
Cable Operated Flange Mechanism and Cable 200A Only - must select Mechanism ⁽³⁾ <i>and</i> Cable ⁽⁴⁾							
Item						Part Number	
Cable Mechanism						FLCM	
36" (900mm) Cable						FLC36	
60" (1500mm) Cable						FLC60	
120" (3000mm) Cable						FLC120	
Accessories		OR					
		NFPA Through the Door Handle Kit - to be used with front pistol handle					
	Use with Switch	Color	Test Function	Padlockable	Defeatable	Part Number	
	RDF200J- <u> </u>	Red	N	Y	N	H79-2	
and ...							
Auxiliary Contacts							
	Contact Type	Number of Contacts	Continuous Amp Rating	Voltage Rating	Max Number of Aux Contacts per Switch	Part Number	
	NO	1	10A	600Vac	RDF200J- <u> </u> : 4	BAC05	
					RDF400J- <u> </u> : 8	BAC06	
SHROUDS		and ...					
		Terminal Shrouds - includes terminal shroud for lineside or loadside					
	Switch Amp Rating	Number of Poles				Part Number	
	200	2				TSH8-2TB	
	200	3				TSH8-3TB	
	200	4				TSH8-4TB	
	400	2				TSH9-2TB	
	400	3				TSH9-3TB	
						TSH9-4TB	

Disconnect Switches

Dimensions – in (mm)

• RDF200J-3

• RDF400J-3

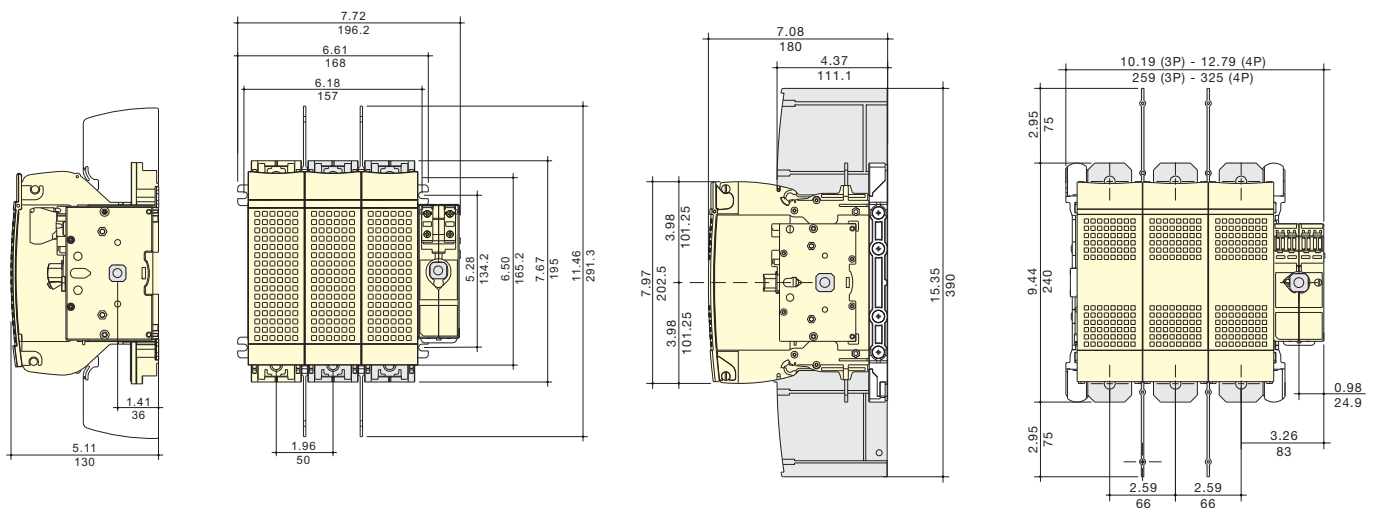

UL 98 Fused Rotary Disconnect Switches—200 & 400A Standard Class J

Direct Mount Handle

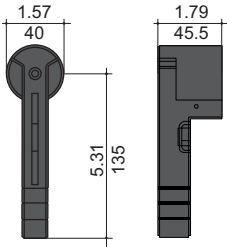

DIR-07

Flange Handle

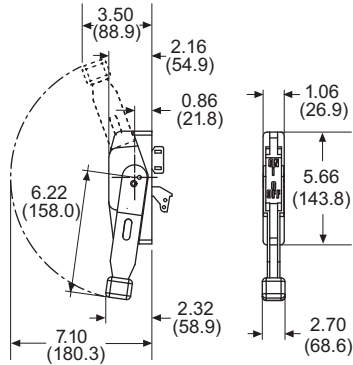

FLH_

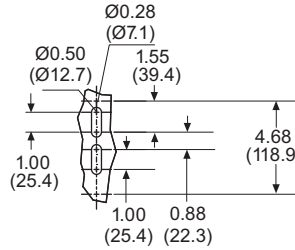

External Front & Right Side Pistol Handle

Handle Type

Direction of Front Operation

Direction of Right Side Operation

Door Drilling Layout

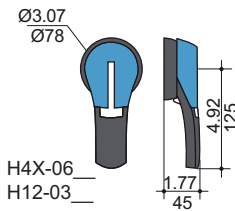

H4X-06
H12-03

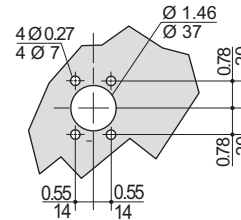
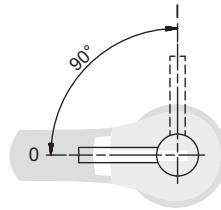
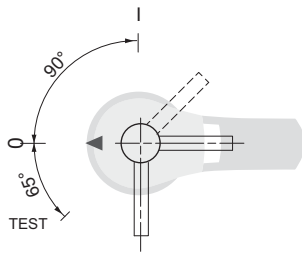

Terminal Lugs

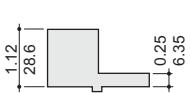
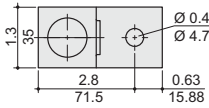
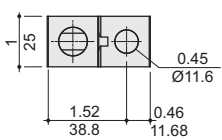

200A

LUG1-__

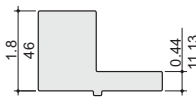

400A

LUG2-__



Disconnect
Switches

Open & Enclosed Rotary Disconnect Switches In-Stock and Ship Within 24 Hours

The Bussmann QuikShip Everyday Service ensures the most common open and enclosed rotary disconnect switches ship within 24 hours to help you meet project timelines.

Contact your Bussmann representative for details.



QuikShip 
Everyday

www.cooperbussmann.com/Disconnects



UL 98 Fused Rotary Disconnect Switches—600 & 800A

Standard Class J & Class L

For a Complete Assembly, Please Select:

Select for Standard Applications		Switch							
		Amp Rating	Fuse Class	Number of Poles	SCCR	Max Horsepower Rating, 3-Phase			Part Number
						220/240Vac	440/480Vac	600Vac	
		600	J	2	200kA	-	-	-	RDF600J-2
		600	J	3	200kA	200	400	500	RDF600J-3
		600	J	4	200kA	200	400	500	RDF600J-4
		800	L	2	200kA	-	-	-	RDF800L-2
		800	L	3	200kA	200	500	500	RDF800L-3
		800	L	4	200kA	200	500	500	RDF800L-4
		Terminal Lug Kit							
Switch Amp Rating	Number of Poles	Lugs Per Kit	Wire Range			Wire Type	Part Number		
600-800	2	2	(2) #2-600MCM			75°C Cu/Al	LUG5-2		
600-800	3	3	(2) #2-600MCM			75°C Cu/Al	LUG5-3		
600-800	4	4	(2) #2-600MCM			75°C Cu/Al	LUG5-4		
+									
Accessories		Direct Mount Handle - mounts directly to switch, no shaft required							
		For Switch Part Number	Color	Test Function	Padlockable	Part Number			
		All Switches	Black	Y	Y	DIR-08			
		OR							
		External Front Operated Pistol Handles - shaft required							
		NEMA Type	Color	Test Function	Padlockable	Defeatable	Part Number		
		1, 3R, 4, 4X, 12	Black	N	Y	Y	H4X-07B		
		1, 3R, 4, 4X, 12	Red/Yellow	N	Y	Y	H4X-07R		
		Metallic Hasp (Heavy Duty) External Front Operated Pistol Handles - shaft required							
		NEMA Type	Color	Test Function	Padlockable	Defeatable	Part Number		
1, 3R, 4, 4X, 12	Black	N	Y	Y	H4X-07BHD				
1, 3R, 4, 4X, 12	Red/Yellow	N	Y	Y	H4X-07RHD				
Shafts for Pistol Handles									
Length in (mm)	Mounting Depth (X) in (mm)			Part Number					
7.9 (200)	10.63~11.97 (270~304)			SH7-200					
12.6 (320)	10.63~16.69 (270~424)			SH7-320					
15.7 (400)	10.63~19.84 (270~504)			SH7-400					
OR									
NFPA Through the Door Handle Kit - to be used with front pistol handle									
For Switch Part Number	Color	Test Function	Padlockable	Defeatable	Part Number				
All Switches	Red	N	Y	N	H79-4				
and ...									
Accessories		Auxiliary Contacts							
		Contact Type	Number of Contacts	Continuous Amp Rating	Voltage Rating	Max Number of Aux Contacts per Switch	Part Number		
		NO	1	10A	600Vac	8	BAC05		
		NC	1	10A	600Vac	8	BAC06		
		and ...							
		Terminal Shrouds - includes terminal shroud for lineside or loadside							
		Switch Amp Rating	Number of Poles	Part Number					
		600-800	2	TSH10-2TB					
		600-800	3	TSH10-3TB					
		600-800	4	TSH10-4TB					

UL 98 Fused Rotary Disconnect Switches—600 & 800A

Standard Class J & Class L

Dimensions – in (mm)

- RDF600J-3 • RDF800L-3

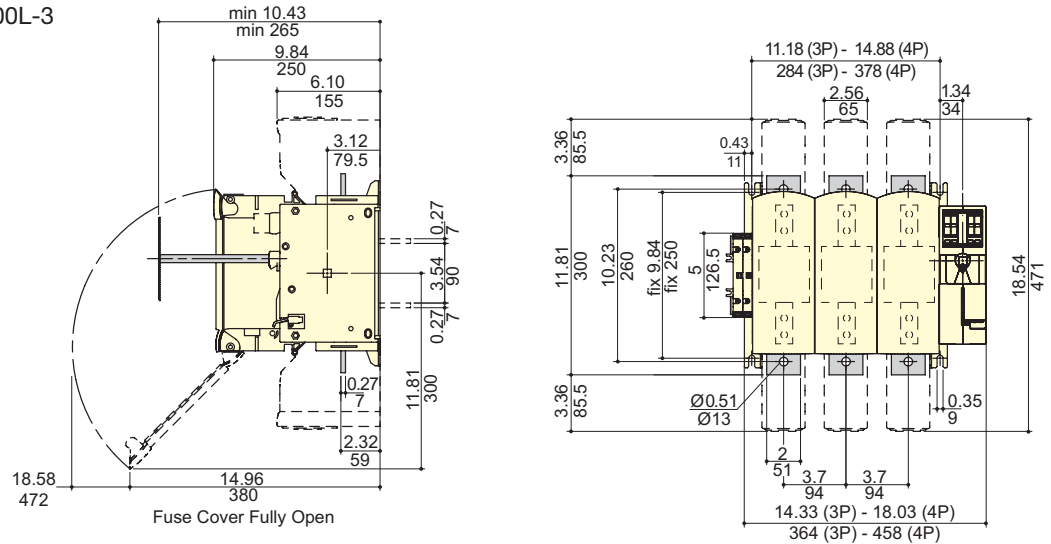

Direct Mount Handle

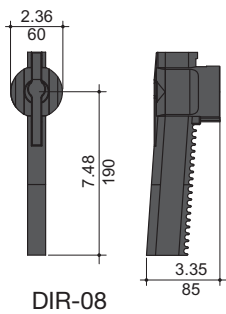

External Front Pistol Handle

Handle Type

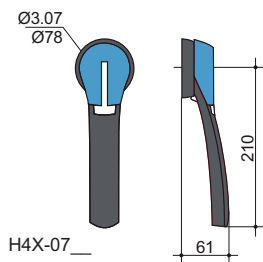

Direction of Front Operation

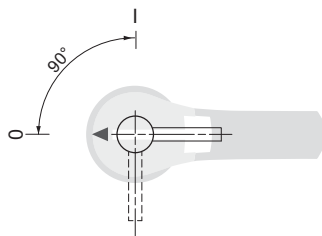

Door Drilling Layout

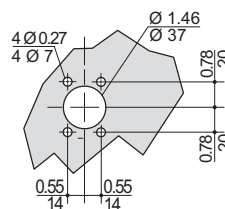

Terminal Lugs

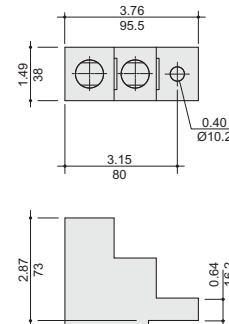

600 to 800A

LUG5-__

Disconnect Switches

UL 98 Non-Fused Rotary Disconnect Switches—30 to 1200A

Description

Bussmann UL 98 non-fused rotary disconnect switches are versatile switches that “break” and “make” power circuits ON and OFF load.

Features

- Make and break power under load
- Up to 200kA SCCR
- DIN-Rail or panel mount (30-100A)
- Disconnect switches are front, right side and direct handle operable (30-100A)
- Finger-safe (30-100A)
- Fully visualized breaking (100-1200A)

Agency Information

- UL98, Guide WHTY, File E155130
- CSA 22.2 No. 4, File 257020
- Conforms with IEC 60947-3

Online Resources

Visit www.cooperbussmann.com/Disconnects for:

- CAD Drawings
- Instruction Sheets
- UL Information



QuikShip Everyday Service ships the most common part numbers within 24 hours. Contact your Bussmann representative for details.

Related Cooper Bussmann Products

Fuse Blocks	Data Sheet #
Modular Knifeblade Fuse Blocks 100-600A	3192
Fuses Holders	
CH Series Class CC, Midget & 10x38 0-30A	3185
Finger-Safe Optima Series 0-30A	1102
Optima™ Protection Modules 0-30A	1109
CH Series Class J 0-60A	2144

IEC Electrical Specifications



Part Number	RD30-3	RD60-3	RD100-3	RD100-3-SCCR	RD200-3	RD400-3	RD600-3	RD800-3	RD1000-3	RD1200-3
3-Pole	RD30-3	RD60-3	RD100-3	RD100-3-SCCR	RD200-3	RD400-3	RD600-3	RD800-3	RD1000-3	RD1200-3
4-Pole	—	—	—	—	RD200-4	RD400-4	RD600-4	RD800-4	RD1000-4	RD1200-4
Thermal Current I_{th} @ 40°C (A)	30	60	100	—	—	—	—	—	—	—
Rated insulation voltage U_i (V)	800	800	800	—	—	—	1000	1000	1000	1000
Rated impulse withstand voltage U_{imp} (kV)	8	8	8	—	—	—	12	12	12	12
Rated Operation Currents I_e (A)										
Load Duty Category	A ⁽¹⁾	A ⁽¹⁾	A ⁽¹⁾	—	—	—	A ⁽¹⁾	A ⁽¹⁾	A ⁽¹⁾	A ⁽¹⁾
Rated Voltage	—	—	—	—	—	—	—	—	—	—
400Vac AC-22 A	32	63	100	—	—	—	630	800	1000	1200
400Vac AC-23 A	32	63	100	—	—	—	630	800	1000	1000
690Vac AC-22 A	32	63	80	—	—	—	500	630	630	630
690Vac AC-23 A	32	63	63	—	—	—	200	400	400	400
Operational Power (Vac) in AC-23 (kW)										
400V w/o prebreak AC ⁽¹⁾⁽²⁾	15	30	45	—	—	—	355	450	560	560
500V w/o prebreak AC ⁽¹⁾⁽²⁾	15	30	45	—	—	—	450	560	560	560
690V w/o prebreak AC ⁽¹⁾⁽²⁾	18.5	30	45	—	—	—	185	400	400	400
Overload Capacity (U_e 415Vac)										
Rated short-time making capacity I_{cm} (kA peak) ⁽³⁾	12	12	12	—	—	—	48	75	48	75
Fuse Protected Short-Circuit Withstand (kA rms prospective)										
Short-Circuit Current (kA) ⁽³⁾	50	50	25	—	—	—	100	100	100	100
Associated Fuse Rating (A) ⁽³⁾	32	63	100	—	—	—	630	800	1000	1250
Connection										
Minimum Cu cable cross section (mm ²)	2.5	2.5	10	—	—	—	2x150	2x185	2x240	—
Minimum Cu busbar section (mm ²)	—	—	—	—	—	—	2x30x5	2x40x5	2x50x5	2x60x5
Maximum Cu cable section (mm ²)	70	70	70	—	—	—	—	—	—	—

(1) A/B: Category with index A = frequent operation; category with index B = infrequent operation.

(2) The power value is given for information only; the current values vary from one manufacturer to another.

(3) For a rated operating voltage, $U_e = 400$ Vac.

UL 98 Non-Fused Rotary Disconnect Switches—30 to 1200A

Specifications



RD30-3



RD200-3



RD600-3







Part Number	RD30-3	RD60-3	RD100-3	RD100-3-SCCR	RD200-3	RD400-3	RD600-3	RD800-3	RD1000-3	RD1200-3
3-Pole	—	—	—	—	RD200-4	RD400-4	RD600-4	RD800-4	RD1000-4	RD1200-4
4-Pole	—	—	—	—	—	—	—	—	—	—
UL Standard	UL 98	UL 98	UL 98	UL 98	UL 98	UL 98	UL 98	UL 98	UL 98	UL 98
Max Ampacity	30A	60A	100A	100A	200A	400A	600A	800A	1000A	1200A
Switch Type	Compact	Compact	Compact	Standard	Standard	Standard	Standard	Standard	Standard	Standard
Handle Operation	Front/Side	Front/Side	Front/Side	Front	Front	Front	Front	Front	Front	Front
UL Electrical Ratings										
Max Voltage (AC)	600Vac	600Vac	600Vac	600Vac	600Vac	600Vac	600Vac	600Vac	600Vac	600Vac
Max Voltage (DC)	—	—	—	250Vdc	250Vdc	—	250Vdc	—	—	—
Maximum AC Horsepower Ratings										
1-Phase, 120Vac	2	3	5	—	—	—	—	—	—	—
1-Phase, 240Vac	5	10	10	10	10	—	—	—	—	—
3-Phase, 240Vac	10	20	20	30	75	125	200	200	200	200
3-Phase, 480Vac	20	40	50	75	150	250	400	500	500	500
3-Phase, 600Vac	25	50	50	100	200	350	350	500	500	500
DC Horsepower Ratings										
125Vdc	—	—	—	—	—	—	20	—	—	—
250Vdc	—	—	—	—	—	—	50	—	—	—
Electrical Characteristics										
SCCR with Fuse	100kA	100kA	25kA/100kA*	200kA	200kA	200kA	200kA	100kA	100kA	100kA
Fuse Class	J	J	J	J	J	J	J	L	L	L
Max. Fuse Rating	30A	60A	100A	100A	200A	400A	600A	800A	1000A	1200A
Terminal Lugs/Kits	Integral	Integral	Integral	•	•	•	•	•	•	•
Lug Mounting Torque - Lb-In (N•m)	-	-	-	160 (18)	160 (18)	LUG2-... 310 (35) LUG3-... 398 (45)	310 (35)	310 (35)	310 (35)	310 (35)
Wire Type	75°C Cu	75°C Cu	75°C Cu	75°C Cu/Al	75°C Cu/Al	75°C Cu/Al	75°C Cu/Al	75°C Cu/Al	75°C Cu/Al	75°C Cu/Al
Wire Range & Torque - Lb-In (N•m)										
Solid	#12-10 35.4 (4)	#12-10 35.4 (4)	#12-10 35.4 (4)	—	—	—	—	—	—	—
Stranded	#10-1 35.4 (4) 1/0 39.8 (4.5) 2/0 44.3 (5)	#10-1 35.4 (4) 1/0 39.8 (4.5) 2/0 44.3 (5)	#10-1 35.4 (4) 1/0 39.8 (4.5) 2/0 44.3 (5)	#6-300MCM 275 (31)	#6-300MCM 275 (31)	LUG2-... #4-600MCM 550 (62) Dual 1/0-250MCM 550 (62) LUG3-... (2) #6-2 200 (22.6) (2) #1-350MCM 375 (42.4)	(2) #2-600MCM 375 (42.4)	(4) #2-600MCM 375 (42.4)	(4) #2-600MCM 375 (42.4)	(4) #2-600MCM 375 (42.4)
Mechanical Characteristics										
Endurances/Cycles	10,000	10,000	10,000	10,000	8000	6000	6000	3500	3500	3500
Physical Characteristics										
Dimensions	See drawings on product pages									
Weight - Lbs (KG)										
3-Pole	1.3 (0.6)	1.3 (0.6)	1.3 (0.6)	4.2 (1.91)	4.2 (1.91)	10.0 (4.6)	18.1 (8.2)	19.6 (8.9)	19.6 (8.9)	19.6 (8.9)
4-Pole	—	—	—	—	5.0 (2.3)	12.3 (5.6)	23.9 (10.9)	25.3 (11.5)	25.3 (11.5)	25.3 (11.5)
Environmental										
Operating Temperature	-20°C to 70°C	-20°C to 70°C	-20°C to 70°C	-20°C to 70°C	-20°C to 70°C	-20°C to 70°C	-20°C to 70°C	-20°C to 70°C	-20°C to 70°C	-20°C to 70°C
Flammability Rating	UL 94-V0	UL 94-V0	UL 94-V0	UL 94-V0	UL 94-V0	UL 94-V0	UL 94-V0	UL 94-V0	UL 94-V0	UL 94-V0
Accessories										
Lug Kit Part #										
3-Pole	Integral	Integral	Integral	•	•	•	•	•	•	•
4-Pole	—	—	—	—	—	—	—	—	—	—
Handles										
NEMA 1, 3R, 12	•	•	•	•	•	•	—	—	—	—
NEMA 1, 3R, 4, 4X, 12	•	•	•	•	•	•	•	•	•	•
Direct	•	•	•	•	•	•	•	•	•	•
Front Pistol	—	—	—	•	•	•	•	•	•	•
Front or Side Selector	•	•	•	—	—	—	—	—	—	—
Shaft c/s - mm	5x5	5x5	5x5	10x10	10x10	10x10	12x12	12x12	12x12	12x12
Shaft Guide	•	•	•	•	•	•	•	•	•	•
Shrouds	•	•	•	•	•	•	•	•	•	•
Additional Pole Accessory	•	•	•	—	—	—	—	—	—	—
Auxiliary Contacts										
NO + NC	•	•	•	•	•	•	•	•	•	•
(2) NO	•	•	•	—	—	—	—	—	—	—

Disconnect Switches

• Available, see product page for details and part numbers.
 — Not available.
 * 25kA @ 600Vac, 100kA @ 480Vac.

UL 98 Non-Fused Rotary Disconnect Switches—30, 60 and Compact 100A

For a Complete Assembly, Please Select:

Select for Standard Applications	SWITCH		Switch											
			Switch Amp Rating	No. of Poles	SCCR	Max Horsepower Rating					Wire Size	Wire Type	Part Number	
						1-Phase		3-Phase						
						120 Vac	220/240Vac	220/240Vac	440/480Vac	600 Vac				
	30	3	100kA	2	5	10	20	25	#10-2/0 Str #12-10 Sol	75°C Cu	RD30-3			
	60	3	100kA	3	10	20	40	50	#10-2/0 Str #12-10 Sol	75°C Cu	RD60-3			
	100	3	25/100kA*	5	10	20	50	50	#10-2/0 Str #12-10 Sol	75°C Cu	RD100-3			
	* 100kA @480Vac, 25kA @ 600Vac.													
	Accessories	HANDLES		Direct Mount Handle - mounts directly to switch, no shaft required								Part Number		
				For Switch Part Number	Color		Test Function	Padlockable						
All Switches		Black		N	Y - On Switch				DIR-02					
OR														
SW. 4 TH POLE		AUX CONTACTS		External Front or Right Side Operated Selector Handles - shaft required								Part Number		
				NEMA Type	Color	Handle Length	Test Function	Padlockable	Defeatable					
				1, 3R, 4, 4X, 12	Black	Short	N	Y	Y		H4X-01B ⁽¹⁾			
				1, 3R, 4, 4X, 12	Red/Yellow	Short	N	Y	Y		H4X-01R ⁽¹⁾			
				1, 3R, 4, 4X, 12	Black	Long	N	Y	Y		H4X-02B ⁽²⁾			
				1, 3R, 4, 4X, 12	Red/Yellow	Long	N	Y	Y		H4X-02R ⁽²⁾			
	Shafts for Selector Handles								Part Number					
	Length in (mm)			Mounting Depth (X) in (mm)										
	5.9 (150)			3.50~7.60 (89~193)						SH4-150				
	7.9 (200)			3.50~9.50 (89~241)						SH4-200				
12.6 (320)	3.50~14.9 (89~378)						SH4-320							
Shaft Guide								Part Number						
Required for 12.6" (320mm) long shafts, optional for other lengths								SH-GUIDE1						
and ...														
SW. 4 TH POLE	SHROUDS		Auxiliary Contacts								Part Number			
			Contact Type	Number of Contacts	Continuous Amp Rating	Voltage Rating	Max Number of Aux Contacts per Switch							
			NO + NC	1 of each	10A	240Vac	4			BAC01				
			NO	2	10A	240Vac	4			BAC02				
			and ...											
			SW. 4 TH POLE	SHROUDS		Terminal Shrouds - includes terminal shroud for both lineside and loadside								Part Number
						Switch Amp Rating	Number of Poles	Location on Switch						
						All Switches	1 (for switched 4 th pole)	Lineside and Loadside					TSH3-1TB	
						All Switches	3	Lineside and Loadside					TSH3-3TB	
						and ...								
SW. 4 TH POLE	SHROUDS					Switched 4th Pole - converts 3-pole switch to 4-pole								Part Number
						Switch Amp Rating								
						30							POLE98-30	
						60							POLE98-60	
						100							POLE98-100	



Auxiliary Contact Configurations

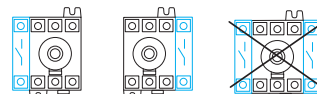

Possible 4th Pole Configurations

UL 98 Non-Fused Rotary Disconnect Switches—30, 60 and Compact 100A

Dimensions - in (mm)

Direct Handle Operation

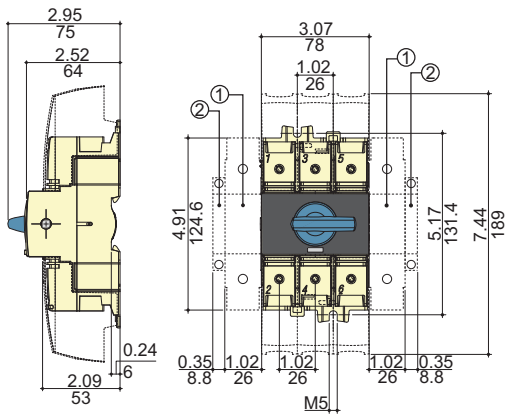

External Front Operation

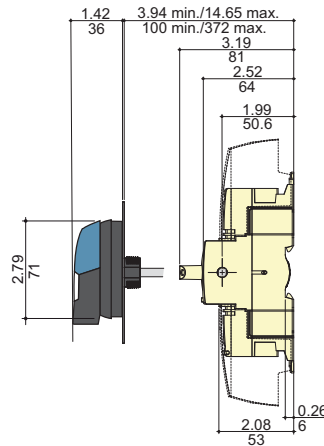

External Right Side Operation

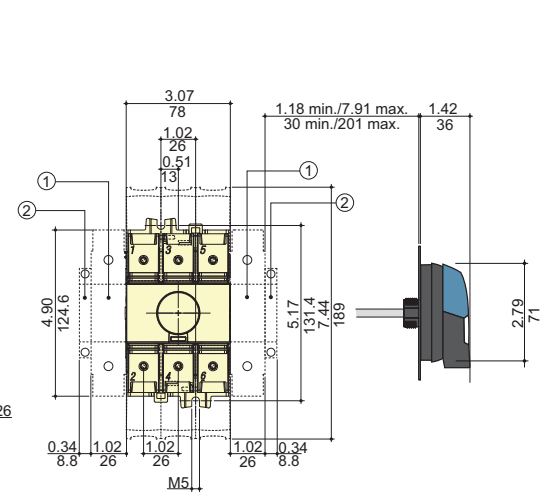

1. Position for 1 switched 4th pole (1 per device max.) or 1 auxiliary contact.
 2. Position for 1 auxiliary contact only.
- Note: Maximum of 4 auxiliary contacts, or 3 auxiliary contacts + one switched 4th pole.

Disconnect Switches

External Front or Right Side Operated Selector Handle

Handle Type

Direction of Front Operation Direction of Right Side Operation

Door Drilling Layouts

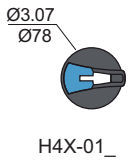

H4X-01_

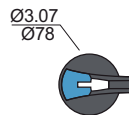



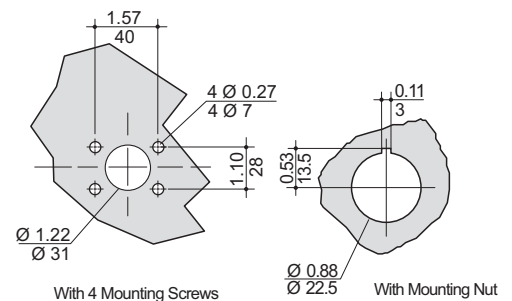
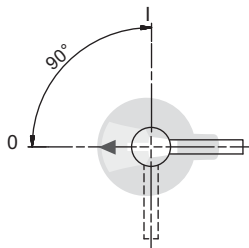
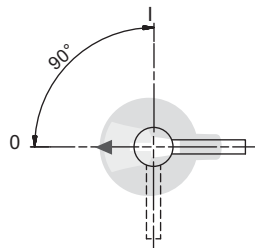



H4X-02_

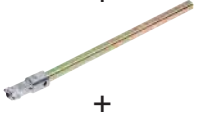

UL 98 Non-Fused Rotary Disconnect Switches—100, 200 and 400A

For a Complete Assembly, Please Select:

Switch + Lugs	 + 	Switch								
		Switch Amp Rating	No. of Poles	SCCR	Max Horsepower Rating				Part Number	
					1-Phase 220/240Vac	220/240Vac	3-Phase 440/480Vac		600 Vac	
		100	3	200kA	10	30	75	100	RD100-3-SCCR	
		200	3	200kA	10	75	150	200	RD200-3	
		200	4	200kA	10	75	150	200	RD200-4	
		400	3	200kA	-	125	250	350	RD400-3	
		400	4	200kA	-	125	250	350	RD400-4	
		Terminal Lug Kit								
		Switch Amp Rating	No. of Poles	Lugs Per Kit	Wire Range			Wire Type	Part Number	
100-200	2	2	#6-300MCM			75°C Cu/Al	LUG1-2			
100-200	3	3	#6-300MCM			75°C Cu/Al	LUG1-3			
100-200	4	4	#6-300MCM			75°C Cu/Al	LUG1-4			
400	2	2	#4-600MCM or Dual 1/0-250MCM			75°C Cu/Al	LUG2-2			
400	3	3	#4-600MCM or Dual 1/0-250MCM			75°C Cu/Al	LUG2-3			
400	4	4	#4-600MCM or Dual 1/0-250MCM			75°C Cu/Al	LUG2-4			
400	2	2	(2) #6-350MCM			75°C Cu/Al	LUG3-2			
400	3	3	(2) #6-350MCM			75°C Cu/Al	LUG3-3			
400	4	4	(2) #6-350MCM			75°C Cu/Al	LUG3-4			
HANDLE	 +  or  +  + 	Direct Mount Handle - mounts directly to switch, no shaft required								
		For Switch Part Number	Color	Test Function	Padlockable			Part Number		
		All Switches	Black	N	Y			DIR-03		
OR										
External Front Operated Pistol Handles - shaft required										
NEMA Type	Color	Test Function	Padlockable	Defeatable			Part Number			
1, 3R, 12	Black	N	Y	Y			H12-03B			
1, 3R, 12	Red/Yellow	N	Y	Y			H12-03R			
1, 3R, 4, 4X, 12	Black	N	Y	Y			H4X-06B			
1, 3R, 4, 4X, 12	Red/Yellow	N	Y	Y			H4X-06R			
Metallic Hasp (Heavy Duty) External Front Operated Pistol Handles - shaft required										
NEMA Type	Color	Test Function	Padlockable	Defeatable			Part Number			
1, 3R, 4, 4X, 12	Black	N	Y	Y			H4X-06BHD			
1, 3R, 4, 4X, 12	Red/Yellow	N	Y	Y			H4X-06RHD			
Shafts for Pistol Handles										
Length in (mm)	Mounting Depth (X) in (mm)					Part Number				
7.9 (200)	5.31~10.43 (135~265)					SH5-200				
12.6 (320)	5.31~15.16 (135~385)					SH5-320				
15.7 (400)	5.31~18.31 (135~465)					SH5-400				
Shaft Guide							Part Number			
Required for 15.7" (400mm) long shafts, optional for other lengths						SH-GUIDE2				
and ...										
Accessories		Auxiliary Contacts								
		Contact Type	Number of Contacts	Continuous Amp Rating	Voltage Rating	Max Number of Aux Contacts per Switch	Part Number			
		NO + NC	1 of each	10.1A	125-250Vac	2	BAC03*			
		NO + NC	1 of each	10.1A	125-250Vac	2	BAC04*			
		NO + NC	1 of each	1A	125Vac	2	BAC11*			
		NO + NC	1 of each	1A	125Vac	2	BAC12*			
* For one auxiliary contact, install either BAC03 or BAC11. For two auxiliary contacts, install BAC03 + BAC04, or BAC11 + BAC12.										

UL 98 Non-Fused Rotary Disconnect Switches—100, 200 and 400A

and ...

Accessories SHROUDS		Terminal Shrouds - includes terminal shroud for lineside or loadside			
		Switch Amp Rating	Number of Poles	Location on Switch	Part Number
		100-200A	3	Lineside	TSH4-3T
		100-200A	3	Loadside	TSH4-3B
		100-200A	4	Lineside or Loadside	TSH4-4TB
		400A	3	Lineside	TSH5-3T
		400A	3	Loadside	TSH5-3B
		400A	4	Lineside or Loadside	TSH5-4TB

Dimensions - in (mm)

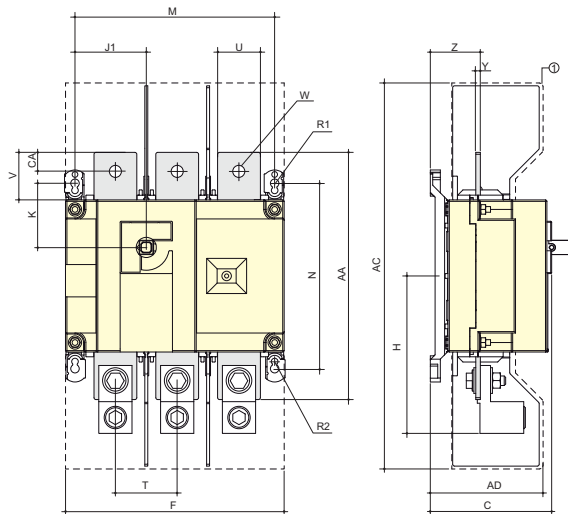

Terminal Lugs

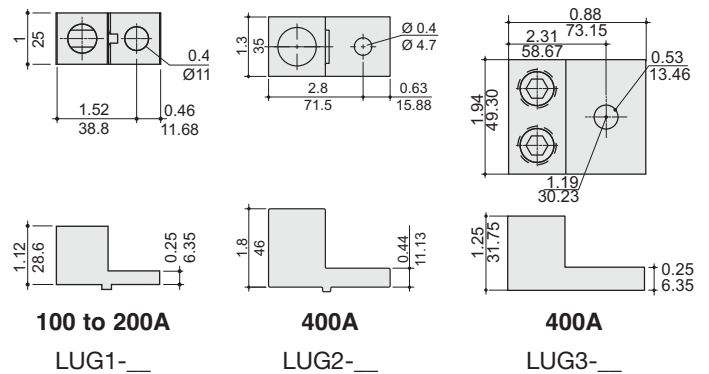

Disconnect Switches

Switch Rating (A)	Overall Dimen. C	Terminal Shrouds		Switch Body						Switch Mounting				Connection								
		AC	AD	F 3p.	F 4p.	H	J1 3p.	J1 4p.	K	M 3p.	M 4p.	N	R1	R2	T	U	V	W	Y	Z	AA	AC
100	3.72 (94.6)	10.1 (256)	3.05 (77.5)	7.09 (180)	9.06 (230)	4.22 (107)	2.17 (55)	4.13 (105)	1.8 (45.6)	6.3 (160)	8.27 (210)	5.31 (135)	0.35 (9)	0.27 (7)	1.97 (50)	0.98 (25)	1.18 (30)	0.43 (11)	0.14 (3.5)	1.35 (34.4)	6.3 (160)	0.6 (15)
200	3.72 (94.6)	10.1 (256)	3.05 (77.5)	7.09 (180)	9.06 (230)	4.22 (107)	2.17 (55)	4.13 (105)	1.8 (45.6)	6.3 (160)	8.27 (210)	5.31 (135)	0.35 (9)	0.27 (7)	1.97 (50)	0.98 (25)	1.18 (30)	0.43 (11)	0.14 (3.5)	1.35 (34.4)	6.3 (160)	0.6 (15)
400	4.92 (128)	16 (406)	4.15 (115)	9.05 (230)	11.4 (290)	6.53 (166)	2.95 (75)	5.31 (135)	2.65 (67.5)	8.26 (210)	10.6 (270)	7.67 (195)	0.35 (9)	0.27 (7)	2.56 (65)	1.77 (45)	1.97 (50)	0.43 (13)	0.2 (5)	2.08 (53)	10.2 (260)	0.8 (20)

Direct Mount Handle

External Front Handle

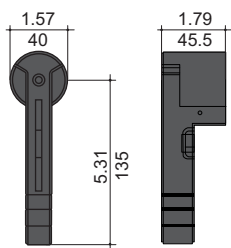

DIR-03

Handle Type



H4X-06
H12-03

Direction of Front Operation

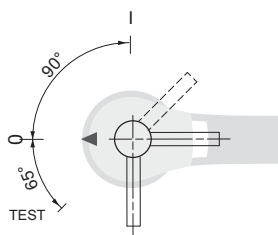

Door Drilling Layout

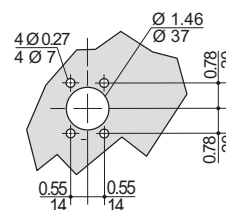

UL 98 Non-Fused Rotary Disconnect Switches—600, 800, 1000 and 1200A

For a Complete Assembly, Please Select:

Select for Standard Applications	SWITCH + LUGS	 	Switch							Part Number		
			Switch Amp Rating	No. of Poles	SCCR	Max Horsepower Rating						
						3-Phase			DC*			
						220/240Vac	440/480Vac	600 Vac	125 Vdc		250 Vdc	
			600A	3	200kA	240	400	350	20		50	RD600-3
			600A	4	200kA	240	400	350	20		50	RD600-4
			800A	3	100kA	200	500	500	-		-	RD800-3
			800A	4	100kA	200	500	500	-		-	RD800-4
			1000A	3	100kA	200	500	500	-		-	RD1000-3
			1000A	4	100kA	200	500	500	-		-	RD1000-4
			1200A	3	100kA	200	500	500	-		-	RD1200-3
			1200A	4	100kA	200	500	500	-		-	RD1200-4
* DC Ratings use two poles in series.												
Accessories	AUX CONTACTS		Auxiliary Contacts									
			Contact Type	Number of Contacts	Continuous Amp Rating	Voltage Rating	Max Number of Aux Contacts per Switch	Part Number				
			NO + NC	1 of each	10.1A	125-250Vac	2	BAC03*				
			NO + NC	1 of each	10.1A	125-250Vac	2	BAC04*				
			NO + NC	1 of each	1A	125Vac	2	BAC11*				
			NO + NC	1 of each	1A	125Vac	2	BAC12*				
			* For one auxiliary contact, install either BAC03 or BAC11. For two auxiliary contacts, install BAC03 + BAC04, or BAC11 + BAC12.									

Switch Amp Rating	No. of Poles	SCCR	Max Horsepower Rating					Part Number
			3-Phase			DC*		
			220/240Vac	440/480Vac	600 Vac	125 Vdc	250 Vdc	
600A	3	200kA	240	400	350	20	50	RD600-3
600A	4	200kA	240	400	350	20	50	RD600-4
800A	3	100kA	200	500	500	-	-	RD800-3
800A	4	100kA	200	500	500	-	-	RD800-4
1000A	3	100kA	200	500	500	-	-	RD1000-3
1000A	4	100kA	200	500	500	-	-	RD1000-4
1200A	3	100kA	200	500	500	-	-	RD1200-3
1200A	4	100kA	200	500	500	-	-	RD1200-4

Terminal Lug Kit						
Switch Amp Rating	No. of Poles	Lugs Per Kit	Lugs Required per Pole	Wire Range	Wire Type	Part Number
600	3	3	1	(2) #2-600MCM	75°C Cu/Al	LUG5-3
600	4	4	1	(2) #2-600MCM	75°C Cu/Al	LUG5-4
800-1200	3	6	2	(4) #2-600MCM	75°C Cu/Al	LUG6-6
800-1200	4	8	2	(4) #2-600MCM	75°C Cu/Al	LUG6-8

Direct Mount Handle - mounts directly to switch, no shaft required					
For Switch Part Number	Color	Test Function	Padlockable	Part Number	
All Switches	Black	N	Y	DIR-04	

External Front Operated Pistol Handles - shaft required					
NEMA Type	Color	Test Function	Padlockable	Defeatable	Part Number
1, 3R, 4, 4X, 12	Black	N	Y	Y	H4X-07B ⁽¹⁾
1, 3R, 4, 4X, 12	Red/Yellow	N	Y	Y	H4X-07R ⁽¹⁾
1, 3R, 4, 4X, 12	Black	N	Y	Y	H4X-08B ⁽²⁾
1, 3R, 4, 4X, 12	Red/Yellow	N	Y	Y	H4X-08R ⁽²⁾

Metallic Hasp (Heavy Duty) External Front Operated Pistol Handles - shaft required					
NEMA Type	Color	Test Function	Padlockable	Defeatable	Part Number
1, 3R, 4, 4X, 12	Black	N	Y	Y	H4X-07BHD ⁽³⁾
1, 3R, 4, 4X, 12	Red/Yellow	N	Y	Y	H4X-07RHD ⁽³⁾
1, 3R, 4, 4X, 12	Black	N	Y	Y	H4X-08BHD ⁽⁴⁾
1, 3R, 4, 4X, 12	Red/Yellow	N	Y	Y	H4X-08RHD ⁽⁴⁾

Shafts for Pistol Handles				Part Number	
Length in (mm)	Mounting Depth (X) in (mm)				
7.9 (200)	8.70~13.50 (221~343)				SH6-200
12.6 (320)	8.70~18.23 (221~463)				SH6-320
15.7 (400)	8.70~21.38 (221~543)		SH6-400		

Shaft Guide		Part Number
Required for 15.7" (400mm) long shafts, optional for other lengths		SH-GUIDE2

and ...

Auxiliary Contacts					
Contact Type	Number of Contacts	Continuous Amp Rating	Voltage Rating	Max Number of Aux Contacts per Switch	Part Number
NO + NC	1 of each	10.1A	125-250Vac	2	BAC03*
NO + NC	1 of each	10.1A	125-250Vac	2	BAC04*
NO + NC	1 of each	1A	125Vac	2	BAC11*
NO + NC	1 of each	1A	125Vac	2	BAC12*

* For one auxiliary contact, install either BAC03 or BAC11. For two auxiliary contacts, install BAC03 + BAC04, or BAC11 + BAC12.

UL 98 Non-Fused Rotary Disconnect Switches—600, 800, 1000 and 1200A

Accessories	SHROUDS	Terminal Shrouds* - includes terminal shroud for lineside or loadside			
		Switch Amp Rating	Number of Poles	Location on Switch	Part Number
		600A	3	Lineside or Loadside	TSH6-3TB
		600A	4	Lineside or Loadside	TSH6-4TB
		800-1200A	3	Lineside or Loadside	TSH7-3TB
		800-1200A	4	Lineside or Loadside	TSH7-4TB

* Shroud for lineside included with switch.

Dimensions - in (mm) 600A

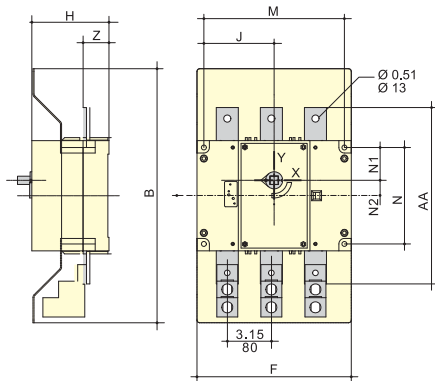

800 to 1200A

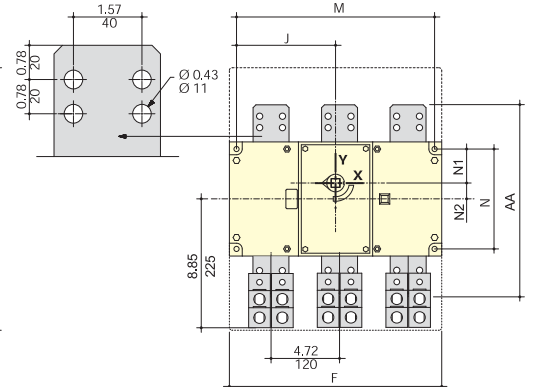

Switch Rating (A)	Terminal Shrouds B	Switch Body				Switch Mounting					Connection		
		F 3p.	F 4p.	H	J 3p.	J 4p.	M 3p.	M 4p.	N	N1	N2	AA	Z
600	18.12 (460)	11 (280)	14.17 (360)	5.5 (140)	5 (127.5)	6.59 (167.5)	10.03 (255)	13.19 (335)	6.88 (175)	2.34 (59.5)	1.10 (28)	12.6 (320)	1.85 (47)
800	18.12 (460)	14.64 (372)	19.37 (492)	5.5 (140)	6.83 (173.5)	9.19 (233.5)	13.66 (347)	18.38 (467)	6.88 (175)	2.34 (59.5)	1.10 (28)	13 (330)	1.85 (47)
1000	18.12 (460)	14.64 (372)	19.37 (492)	5.5 (140)	6.83 (173.5)	9.19 (233.5)	13.66 (347)	18.38 (467)	6.88 (175)	2.34 (59.5)	1.10 (28)	13 (330)	1.85 (47)
1200	18.12 (460)	14.64 (372)	19.37 (492)	5.5 (140)	6.83 (173.5)	9.19 (233.5)	13.66 (347)	18.38 (467)	6.88 (175)	2.34 (59.5)	1.10 (28)	13 (330)	1.85 (47)

External Front Pistol Handles

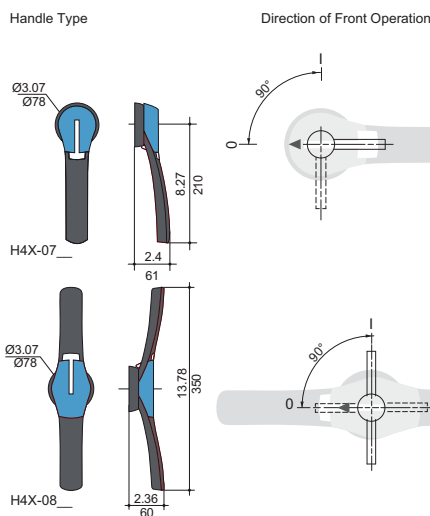

Direct Mount Handle

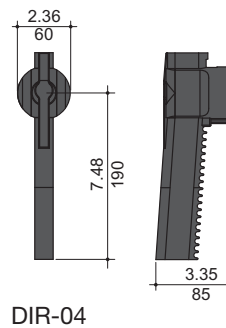

Terminal Lugs

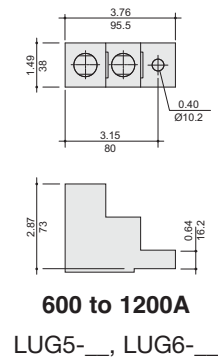

UL 508 Non-Fused Rotary Disconnect Switches—16 to 80A

Description

Bussmann UL 508 load break disconnect switches allow safe control and safe disconnection of any motor application or to isolate a circuit within the panel.

These disconnect switches are compact and offer a wide variety of accessories like 4th poles, auxiliary contacts, door mounting and 6/8-Pole kits.

Features

- Suitable as motor disconnect
- DIN-Rail or panel mount
- Door mount option
- Disconnect switches are front, right side or direct handle operable
- Finger-safe

Agency Information

- UL508, Guide NLRV, File E155129
- CSA C22.2 No. 14, File 257020
- Conforms with IEC 60947-3

Online Resources

Visit www.cooperbussmann.com/Disconnects for:



- CAD Drawings
- Instruction Sheets
- UL Information



QuikShip 
Everyday

QuikShip Everyday Service ships the most common part numbers within 24 hours. Contact your Bussmann representative for details.

Related Cooper Bussmann Products	
Product	Data Sheet #
Fuses Blocks	
Modular Knifeblade Fuse Blocks 100-600A	3192
Fuses Holders	
CH Series Class CC, Midget & 10x38 0-30A	3185
Finger-Safe Optima Series 0-30A	1102
Optima™ Protection Modules 0-30A	1109
CH Series Class J 0-60A	2144

IEC Electrical Specifications		 RD16-3-508		 RD16-3-508 with 6-Pole Conversion Kit	
Part Number	RD16-3-508	RD25-3-508	RD40-3-508	RD63-3-508	RD80-3-508
Thermal Current I_{th} at 40°C (A)	16	25	40	63	80
Rated insulation voltage U_i (V)	800	800	800	800	800
Rated impulse withstand voltage U_{imp} (kV)	8	8	8	8	8
Rated Operation Currents I_o (A)					
Load Duty Category	Rated Voltage	A/B (1)	A/B (1)	A/B (1)	A/B (1)
500Vac	AC-22 A/AC-22 B	16/16	25/25	40/40	80/80
500Vac	AC-23 A/AC-23 B	16/16	25/25	63/63	63/63
690Vac	AC-21 A/AC-21 B	16/16	25/25	63/63	80/80
690Vac	AC-22 A/AC-22 B	16/16	25/25	40/40	63/80
690Vac	AC-23 A/AC-23 B	16/16	25/25	40/40	40/40
Operational Power in AC-23 (kW)					
400Vac without prebreak AC (1)(2)		7.5	11	18.5	30
500Vac without prebreak AC (1)(2)		7.5	11	15	30
690Vac without prebreak AC (1)(2)		7.5	15	18.5	30
Overload Capacity (U_o 415 Vac)					
Rated short-time withstand current 0.3 s. I_{cw} (kA rms) (3)		2.5	2.5	2.5	3
Rated short-time making capacity I_{cm} (kA peak) (3)		6	6	6	9
Fuse Protected Short-Circuit Withstand (kA rms Prospective)					
Prospective short-circuit current (kA rms) (3)		50	50	50	50
Associated fuse rating (A) (3)		16	25	40	63
Connection					
Minimum Cu cable cross section (mm ²)		1.5	1.5	1.5	2.5
Maximum Cu cable section (mm ²)		16	16	16	35
Tightening torque min/max (N·m)		2/2.2	2/2.2	2/2.2	3.5/3.85

(1) A/B: Category with index A = frequent operation; category with index B = infrequent operation.
 (2) The power value is given for information only; the current values vary from one manufacturer to another.
 (3) For a rated operating voltage, $U_o = 400$ Vac.

UL 508 Non-Fused Rotary Disconnect Switches—16 to 80A

Specifications



RD16-3-508







RD16-3-508 with 6-Pole Conversion Kit

Part Number	RD16-3-508	RD25-3-508	RD40-3-508	RD63-3-508	RD80-3-508
UL Standard	UL 508	UL 508	UL 508	UL 508	UL 508
Max Ampacity	16A	25A	40A	63A	80A
Handle Operation	Front/Side	Front/Side	Front/Side	Front/Side	Front/Side
UL Electrical Ratings					
Max Voltage (AC)	600Vac	600Vac	600Vac	600Vac	600Vac
Maximum Horsepower Ratings					
3-Phase, 208Vac	3	7.5	7.5	15	15
3-Phase, 240Vac	5	7.5	7.5	20	20
3-Phase, 480Vac	10	15	20	40	40
3-Phase, 600Vac	10	20	25	40	40
Electrical Characteristics					
SCCR with Fuse	65kA	65kA	10/65kA	50/65kA	50/65kA
Recommended Upstream Fuse Class	J	J	J	J	J
Max. Fuse Rating	30A	30A	60/30A	100/60A	100/60A
Terminals	Integral	Integral	Integral	Integral	Integral
Wire Type	75°C Cu	75°C Cu	75°C Cu	75°C Cu	75°C Cu
Wire Range & Torque - Lb-IN (N·m)					
Solid					
Single	#14-10 26.5 (3)	#14-10 26.5 (3)	#14-10 26.5 (3)	#14-10 31.1 (3.5)	#14-10 31.1 (3.5)
Dual	#12 26.5 (3)	#12 26.5 (3)	#12 26.5 (3)	#12 31.1 (3.5)	#12 31.1 (3.5)
Stranded					
Single	#14-4 26.5 (3)	#14-4 26.5 (3)	#14-4 26.5 (3)	#14-1 31.1 (3.5)	#14-1 31.1 (3.5)
Dual	#14-12 26.5 (3)	#14-12 26.5 (3)	#14-12 26.5 (3)	#10-6 31.1 (3.5)	#10-6 31.1 (3.5)
Mechanical Characteristics					
Endurances/Cycles	10,000	10,000	10,000	10,000	10,000
Physical Characteristics					
Dimensions - See drawings on product pages					
Weight - Lb (KG)	0.5 (0.2)	0.5 (0.2)	0.5 (0.2)	0.7 (0.32)	0.7 (0.32)
Environmental					
Operating Temperature	-20°C to 70°C	-20°C to 70°C	-20°C to 70°C	-20°C to 70°C	-20°C to 70°C
Flammability Rating	UL 94-V0	UL 94-V0	UL 94-V0	UL 94-V0	UL 94-V0
Accessories					
Handles					
Direct	DIR-01	DIR-01	DIR-01	DIR-01	DIR-01
Short Selector/NEMA 1, 3R, 4, 4X, 12	H4X-01B H4X-01R	H4X-01B H4X-01R	H4X-01B H4X-01R	H4X-01B H4X-01R	H4X-01B H4X-01R
Long Selector/NEMA 1, 3R, 4, 4X, 12	H4X-02B H4X-02R	H4X-02B H4X-02R	H4X-02B H4X-02R	H4X-02B H4X-02R	H4X-02B H4X-02R
Shafts - 5x5mm					
5.9"/150mm	SH4-150	SH4-150	SH4-150	SH4-150	SH4-150
7.9"/200mm	SH4-200	SH4-200	SH4-200	SH4-200	SH4-200
12.6"/320mm	SH4-320	SH4-320	SH4-320	SH4-320	SH4-320
Shaft Guide	SH-GUIDE1	SH-GUIDE1	SH-GUIDE1	SH-GUIDE1	SH-GUIDE1
Door Mount Kit	DOOR-508	DOOR-508	DOOR-508	DOOR-508	DOOR-508
Shrouds/Switch Amps					
1-Pole	TSH1-1TB	TSH1-1TB	TSH1-1TB	TSH2-3TB	TSH2-3TB
3-Pole (Loadside and Lineside)	TSH1-3TB	TSH1-3TB	TSH1-3TB	—	—
Switched 4 th Pole/Switch Amps	POLE-16	POLE-25	POLE-40	—	—
Auxiliary Contacts					
NO + NC (1 ea.)	BAC01	BAC01	BAC01	BAC01	BAC01
(2) NO	BAC02	BAC02	BAC02	BAC02	BAC02
AC Ratings					
Volts	240Vac	240Vac	240Vac	240Vac	240Vac
Amps	10A	10A	10A	10A	10A
6-/8-Pole Conversion Kit					
Gangs two switches of same rating, 16-80A switch amps	KIT-6POLE	KIT-6POLE	KIT-6POLE	KIT-6POLE	KIT-6POLE
— Not available.					

Disconnect Switches

UL 508 Non-Fused Rotary Disconnect Switches—16, 25, 40, 63 and 80A



For a Complete Assembly, Please Select:

SWITCH		Switch										
		Switch Amp Rating	No. of Poles	SCCR @600V	Max Class J Fuse	Max Horsepower Rating, 3-Ph				Wire Size	Wire Type	Part Number
						208 Vac	220/240Vac	440/480Vac	600 Vac			
		16	3	65kA	30A	3	5	10	10	#14-#10 Sol Dual #12 Sol #14-#4 Str Dual #14-#12 Str	75°C Cu	RD16-3-508
		25	3	65kA	30A	7.5	7.5	15	20	#14-#10 Sol Dual #12 Sol #14-#4 Str Dual #14-#12 Str	75°C Cu	RD25-3-508
		40	3	10kA 65kA	60A 30A	7.5	7.5	20	25	#14-#10 Sol Dual #12 Sol #14-#4 Str Dual #14-#12 Str	75°C Cu	RD40-3-508
63	3	50kA 65kA	100A 60A	15	20	40	40	#14-#10 Sol Dual #12 Sol #14-#1 Str Dual #10-#6 Str	75°C Cu	RD63-3-508		
80	3	50kA 65kA	100A 60A	15	20	40	40	#14-#10 Sol Dual #12 Sol #14-#1 Str Dual #10-#6 Str	75°C Cu	RD80-3-508		
+												
Select for Standard Applications		Direct Mount Handle - mounts directly to switch, no shaft required										
		For Switch Part Number	Color	Test Function	Padlockable	Part Number						
		All Switches	Black	N	Y - On Switch	DIR-01						
OR												
HANDLE		External Front or Right Side Operated Selector Handles - shaft required										
		NEMA Type	Color	Handle Length	Test Function	Padlockable	Defeatable	Part Number				
		1, 3R, 4, 4X, 12	Black	Short	N	Y	Y	H4X-01B ⁽¹⁾				
		1, 3R, 4, 4X, 12	Red/Yellow	Short	N	Y	Y	H4X-01R ⁽¹⁾				
		1, 3R, 4, 4X, 12	Black	Long	N	Y	Y	H4X-02B ⁽²⁾				
		1, 3R, 4, 4X, 12	Red/Yellow	Long	N	Y	Y	H4X-02R ⁽²⁾				
		Shafts for Selector Handles - required for 12.6" (320mm) shafts										
		Length in (mm)	Mounting Depth (X) in (mm)	Part Number								
		5.9 (150)	3.50-7.60 (89-193)	SH4-150								
		7.9 (200)	3.50-9.50 (89-241)	SH4-200								
12.6 (320)	3.50-14.9 (89-378)	SH4-320										
		Shaft Guide										
		Part Number										
		Required for 12.6" (320mm) long shafts, optional for other lengths.										
		SH-GUIDE1										
		Door Mount Kit - for mounting switch on the right side of the enclosure or directly on the enclosure door using switch side operation shaft location. Kit includes a shaft. <i>Order switch and selector handle separately.</i>										
		Switch Rating	Part Number									
		All Switches - kit includes shaft	DOOR-508									
and ...												
Acc.		Auxiliary Contacts										
		Contact Type	Number of Contacts	Continuous Amp Rating	Voltage Rating	Max Number of Aux Contacts per Switch	Part Number					
		NO + NC	1 Ea	10A	240Vac	4	BAC01					
		NO	2	10A	240Vac	4	BAC02					



Auxiliary Contact Configurations

UL 508 Non-Fused Rotary Disconnect Switches—16, 25, 40, 63 and 80A

		and ...		
SHROUDS		Terminal Shrouds - includes terminal shroud for both lineside <i>and</i> loadside		
		Switch Amp Rating	Number of Poles	Location on Switch
		16-40A	1 (for switched 4 th pole)	Lineside and Loadside
		16-40A	3	Lineside and Loadside
		63-80A	3	Lineside and Loadside
				Part Number
				TSH1-1TB
				TSH1-3TB
				TSH2-3TB
		and ...		
Accessories	SW. 4 TH POLE 	Switched 4th Pole - converts 3-pole switch to 4-pole switch		
		Switch Amp Rating		Part Number
		16		POLE-16
		25		POLE-25
		40		POLE-40
		and ...		
6-POLE KIT		6-Pole Conversion Kit - creates a 6-pole switch by ganging two 3-pole switches of equal rating		
		Switch Amp Rating		Part Number
		All Switches		KIT-6POLE*
	Order switches separately.	* Kit ships with a direct handle. If external handle is needed order a selector handle <i>and</i> shaft for the UL 508 Rotary Disconnect Switches. Note: To create an 8-pole switch from 16 to 40 amp switches, use two 3-pole switches of equal ratings plus two switched 4 th poles (part # POLE-).		

Disconnect Switches

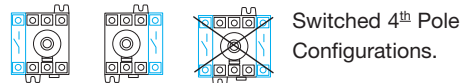

Dimensions – in (mm)

Direct Handle Operation

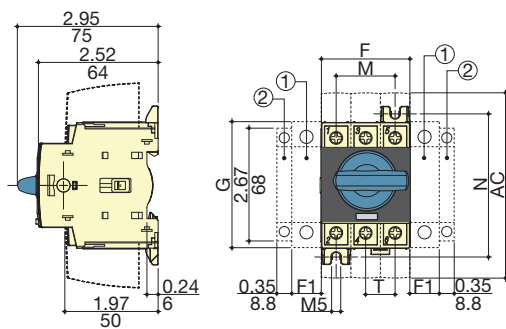

1. Position for 1 switched 4th pole (1 per device max.) or 1 auxiliary contact.
 2. Position for 1 auxiliary contact only.
- Note: Maximum of 4 auxiliary contacts, or 3 auxiliary contacts + one switched 4th pole.

External Front Operation

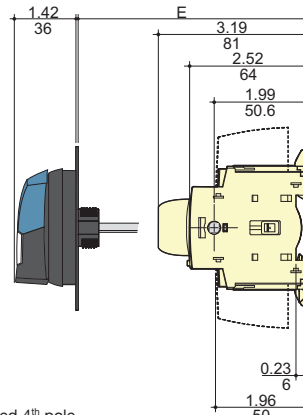

External Side Operation

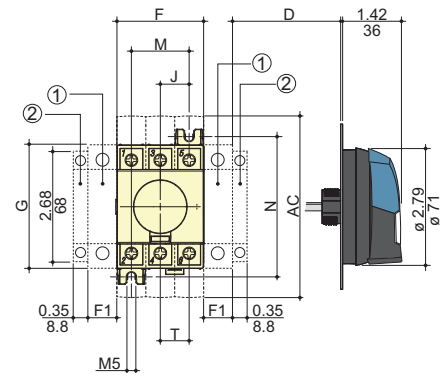

Switch Rating (A)	Overall Dimensions				Terminal Shroud AC	Switch Body				Switch Mounting		Connection T
	D min	D max	E min	E max		F	F1	G	J	M	N	
16 to 40	1.18 (30)	9.25 (235)	3.94 (100)	14.64 (372)	4.33 (110)	1.77 (45)	0.59 (15)	2.67 (68)	0.59 (15)	1.18 (30)	2.95 (75)	0.59 (15)
63 to 80	1.18 (30)	9.25 (235)	3.93 (100)	14.64 (372)	4.33 (110)	2.06 (52.5)	0.69 (17.5)	2.99 (76)	0.69 (17.5)	1.38 (35)	3.35 (85)	0.69 (17.5)

UL 508 Non-Fused Rotary Disconnect Switches—16, 25, 40, 63 and 80A

Dimensions – in (mm)

Direct Front Operation for 6/8-Pole Disconnects

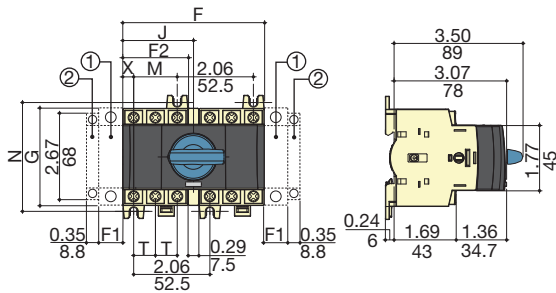

External Front Operation for 6/8-Pole Disconnects

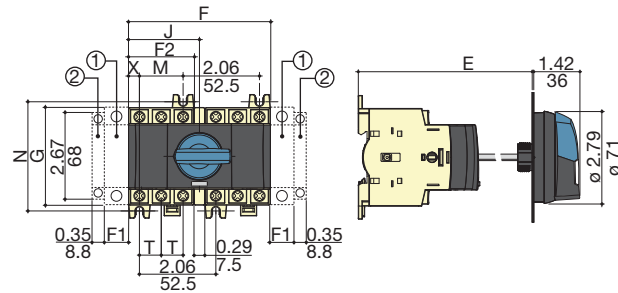

- 1. Position for 1 switched 4th pole (1 per device max.) or 1 auxiliary contact.
 - 2. Position for 1 auxiliary contact only.
- Note: Maximum of 4 auxiliary contacts, or 3 auxiliary contacts + one switched 4th pole.

Switch Rating (A)	Overall Dimensions			Switch Body				Switch Mounting		Connection	
	E min	E max	F	F1	F2	G	J	M	N	T	X
16 to 40	4.13 (105)	14.64 (372)	3.83 (97.5)	0.59 (15)	1.77 (45)	2.67 (68)	1.92 (48.75)	1.18 (30)	2.95 (75)	0.59 (15)	0.29 (7.5)
63 to 80	4.13 (105)	14.65 (372)	4.13 (105)	0.69 (17.5)	2.06 (52.5)	2.99 (76)	2.06 (52.5)	1.38 (35)	3.35 (85)	0.69 (17.5)	0.34 (8.75)

External Selector Handles

Handle Type

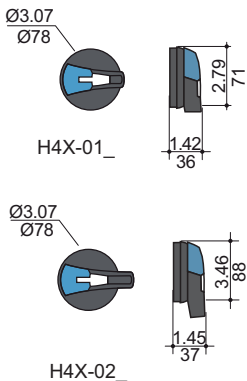

Direction of Front Operation

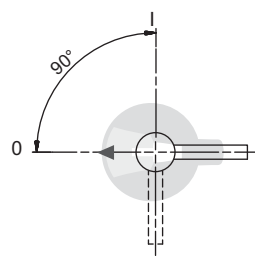

Direction of Right Side Operation

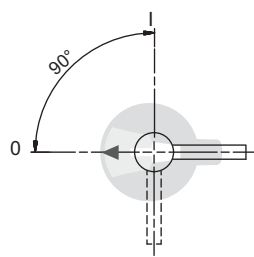

Door Drilling Layouts

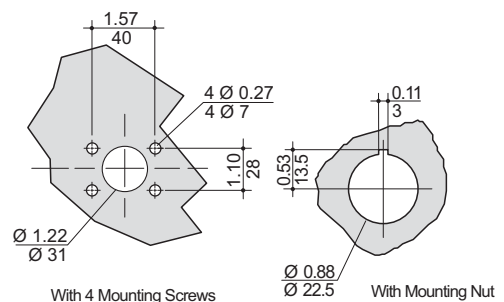

UL 98 & UL 508 Enclosed Disconnect Switches

Description

Fused and non-fused enclosed Rotary Disconnect Switches from 16 to 1200A in NEMA 1, 3R, 4, 4X, 12 enclosures.

Features

- UL 98 Listed for general purpose, main disconnect, or branch circuit protection up to 600Vac/dc
- UL 508 Listed for motor disconnect applications up to 600Vac
- Multiple field installed accessories enhance the enclosed disconnect switches to fit the desired application
- Lockout/tagout: Up to three 1/4" shank padlocks can be installed on external handles

Ratings:

- Volts: 600Vac
250-600Vdc*
- Amps: 16-1200A
- Short-Circuit Current Ratings: UL 98: 25kA-200kA
UL 508: 10kA-65kA

*Some non-fused disconnect switches are not rated for DC applications.

Specifications

- Operating temperature: -20°C to 70°C
- 4X Plastic Enclosure Flammability Rating:
Polycarbonate UL 94-5VA-0
Fiberglass UL 94-5V

Agency Information

- UL 98 Listed: File E182262, Guide WIAX, WIAX7
- UL 508 Listed: File E155129, Guide NLRV, NLRV7
- cULus Listed to CSA Standard 22.2, No. 14
- cULus Listed to CSA Standard 22.2, No. 4
- Conforms with IEC 60947-3
- CE Compliant
- RoHS Compliant

Field Installed Accessories

- Auxiliary contacts
- Terminal shrouds

Online Resources

Visit www.cooperbussmann.com/Disconnects for:

- CAD Drawings
- Instruction Sheets
- UL Information



NEMA 1, 3R, 4 & 12



NEMA 4X
Stainless Steel



NEMA 4X
Polycarbonate
or Fiberglass

QuikShip 
Everyday

QuikShip Everyday Service ships the most common part numbers within 24 hours. Contact your Bussmann representative for details.

Disconnect
Switches

Available Bussmann Fuses

Class	Type	Data Sheet #
CC	LP-CC Time-Delay, Current Limiting	1023
CC	FNQ-R Time-Delay	1014
CC	KTK-R Fast-Acting	1015
J	LPJ Time-Delay, Current Limiting	1006 (0-60A)
J		1007 (70-600A)
J	With easyID™ open fuse indication	1062 (6-60A)
J		1063 (70-600A)
J	JKS Fast-Acting Fuses	1026 (0-60A)
J		1027 (70-600A)
J	DFJ High Speed Drive Fuse	1048 (0-600A)
L	KRP-C Time-Delay, Current Limiting	1008
L	KTU Fast-Acting	1010
L	KLU Time-Delay	1013

UL 98 Enclosed Fused Disconnects—30 to 800A

3-Pole UL 98 600Vac

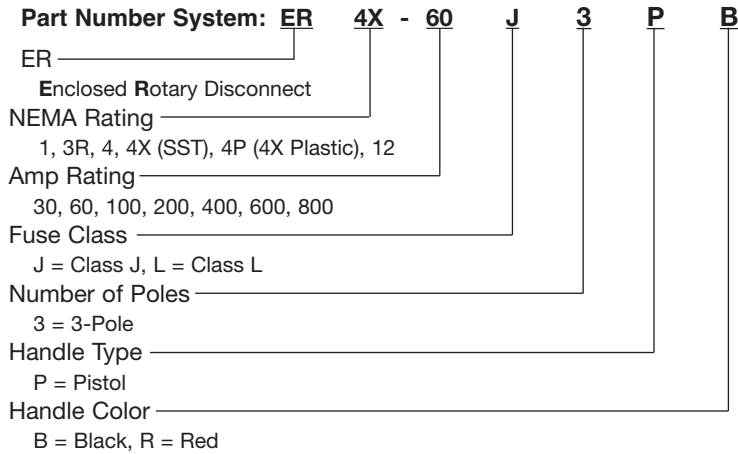

Part Numbers - All part numbers provided with integral or installed lugs and a black selector handle. Order red/yellow handle by changing the suffix “B” to “R.”

UL General Purpose Amp Rating	Fuse Type	NEMA Enclosure Type & Part Number					
		1	3R	4	4X Plastic ⁽¹⁾	4X Stainless	12
30	J	ER1-30J3PB	ER3R-30J3PB	ER4-30J3PB	ER4P-30J3PB	ER4X-30J3PB	ER12-30J3PB
60	J	ER1-60J3PB	ER3R-60J3PB	ER4-60J3PB	ER4P-60J3PB	ER4X-60J3PB	ER12-60J3PB
100	J	ER1-100J3PB	ER3R-100J3PB	ER4-100J3PB	ER4P-100J3PB	ER4X-100J3PB	ER12-100J3PB
200	J	ER1-200J3PB	ER3R-200J3PB	ER4-200J3PB	ER4P-200J3PB	ER4X-200J3PB	ER12-200J3PB
400	J	ER1-400J3PB	ER3R-400J3PB	ER4-400J3PB	ER4P-400J3PB	ER4X-400J3PB	ER12-400J3PB
600	J	ER1-600J3PB	ER3R-600J3PB	ER4-600J3PB	ER4P-600J3PB	ER4X-600J3PB	ER12-600J3PB
800	L	ER1-800L3PB	ER3R-800L3PB	ER4-800L3PB	ER4P-800L3PB	ER4X-800L3PB	ER12-800L3PB

(1) Enclosures ≤100A are polycarbonate, flammability rating UL 94-5VA-V0, ≥200A are fiberglass, flammability rating UL 94-5V.

Switch Ratings - for wire types, ranges and tightening torques, see table on page 387

Switch Amp Rating	Disconnect Switch	Fuse Type	No. of Poles	Voltage		SCCR @ Vac	Max Hp Rating @ 600Vac
				Vac	Vdc		
30	RDF30J-3	J	3	600	250	200kA	20
60	RDF60J-3	J					50
100	RDF100J-3	J					75
200	RDF200J-3	J					150
400	RDF400J-3	J					350
600	RDF600J-3	J		500			
800	RDF800L-3	L		600			

UL 98 Enclosed Fused Disconnects—30 to 800A

Enclosure Weights - Lbs & Dimensions - in

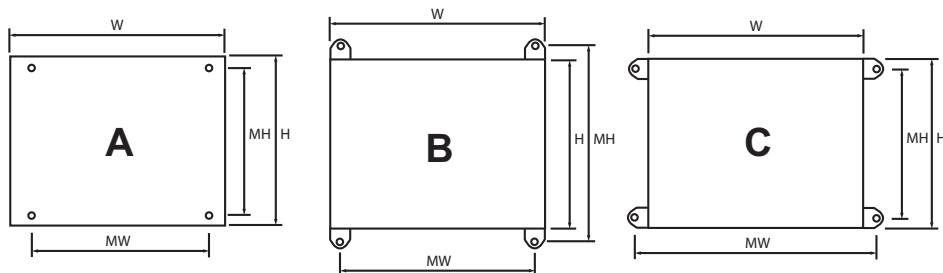



Part Number Family	Amp Rating	Fuse Type	NEMA Enclosure Type	H x W x D	Mounting Centers H x W			Weight Lbs
					A	B	C	
ER_-30J	30	J	1, 3R, 4, 12	10x10x6	8.3x8.3			15
			4X-SST	10x10x6		9.5x8.3	8.3x9.5	15
			4X-Plastic ⁽¹⁾	12x10x6		12x5.6	7.64x10	8
ER_-60J	60	J	1, 3R, 4, 12	12x10x6	10.3x8.3			19
			4X-SST	12x10x6		11.5x8.3	10.3x9.5	19
			4X-Plastic ⁽¹⁾	13x13x6		14x7.6	9.6x12	11
ER_-100J	100	J	1, 3R, 4, 12	14x12x6	12.3x10.3			21
			4X-SST	14x12x6		13.5x10.3	12.3x11.5	21
			4X-Plastic ⁽¹⁾	13x13x6		14x7.6	9.6x12	12
ER_-200J	200	J	1, 3R, 4, 12	24x20x8	22x18.1			55
			4X-SST	24x20x8		23.2x18.1	22x19.3	55
			4X-Plastic ⁽¹⁾	27x21x10		25.75x14		39
ER_-400J	400	J	1, 3R, 4, 12	48x36x12	45.75x34.9			188
			4X-SST	48x36x12		46.9x34.9	45.75x36.1	188
			4X-Plastic ⁽¹⁾	51x37x14		50.1x28.5		186
ER_-600J	600	J	1, 3R, 4, 12	48x36x12	45.75x34.9			216
			4X-SST	48x36x12		46.9x34.9	45.75x36.1	216
			4X-Plastic ⁽¹⁾	51x37x14		50.1x28.5		214
ER_-800L	800	L	1, 3R, 4, 12	48x36x12	45.75x34.9			216
			4X-SST	48x36x12		46.9x34.9	45.75x36.1	216
			4X-Plastic ⁽¹⁾	51x37x14		50.1x28.5		214

(1) Enclosures ≤100A are polycarbonate, flammability rating UL 94-5VA-V0, ≥200A are fiberglass, flammability rating UL 94-5V.

Disconnect Switches

Available Field-Installed Accessories - Order Separately

	Auxiliary Contacts - for 30 to 800 Amp Switches					
	Contact Type	Number of Contacts	Continuous Amp Rating	Voltage Rating	Max Number of Aux Contacts per Switch	Part Number
	NO	1	10A	600Vac	30 to 200A: 4 400 to 800A: 8	BAC05
	NC	1	10A	600Vac		BAC06

	Terminal Shrouds - for 200 to 800 Amp Switches - includes terminal shroud for lineside or loadside		
	Switch Amp Rating	Number of Poles	Part Number
	200	3	TSH8-3TB
	400	3	TSH9-3TB
	600-800	3	TSH10-3TB

UL 98 Enclosed Non-Fused Disconnects—30 to 1200A

3-Pole UL 98 600Vac

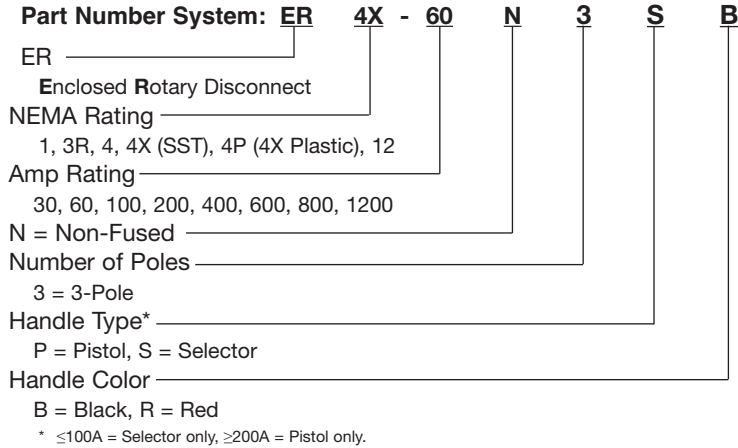

30-100A



NEMA 1, 3R, 4 & 12

NEMA 4X

NEMA 4X Stainless

200-1200A



NEMA 1, 3R, 4 & 12

NEMA 4X

NEMA 4X Stainless

Part Numbers - All part numbers provided with integral or installed lugs and a black selector handle. Order red/yellow handle by changing the suffix "B" to "R."

UL General Purpose Amp Rating	NEMA Enclosure Type & Part Number					
	1	3R	4	4X Plastic ⁽¹⁾	4X Stainless	12
30	ER1-30N3SB	ER3R-30N3SB	ER4-30N3SB	ER4P-30N3SB	ER4X-30N3SB	ER12-30N3SB
60	ER1-60N3SB	ER3R-60N3SB	ER4-60N3SB	ER4P-60N3SB	ER4X-60N3SB	ER12-60N3SB
100	ER1-100N3SB	ER3R-100N3SB	ER4-100N3SB	ER4P-100N3SB	ER4X-100N3SB	ER12-100N3SB
200	ER1-200N3PB	ER3R-200N3PB	ER4-200N3PB	ER4P-200N3PB	ER4X-200N3PB	ER12-200N3PB
400	ER1-400N3PB	ER3R-400N3PB	ER4-400N3PB	ER4P-400N3PB	ER4X-400N3PB	ER12-400N3PB
600	ER1-600N3PB	ER3R-600N3PB	ER4-600N3PB	ER4P-600N3PB	ER4X-600N3PB	ER12-600N3PB
800	ER1-800N3PB	ER3R-800N3PB	ER4-800N3PB	ER4P-800N3PB	ER4X-800N3PB	ER12-800N3PB
1200	ER1-1200N3PB	ER3R-1200N3PB	ER4-1200N3PB	N/A	ER4X-1200N3PB	ER12-1200N3PB

(1) Enclosures ≤100A are polycarbonate, flammability rating UL 94-5VA-V0, ≥200A are fiberglass, flammability rating UL 94-5V.

Switch Ratings - for wire types, ranges and tightening torques, see table on page 405

Switch Amp Rating	Disconnect Switch	No. of Poles	Voltage		SCCR @ Vac	Max Hp Rating @ 600Vac		
			Vac	Vdc				
30	RD30-3	3	600	250	100kA	25		
60	RD60-3						25kA/100kA*	50
100	RD100-3							
200	RD200-3				200			
400	RD400-3							
600	RD600-3				350			
800	RD800-3							
1200	RD1200-3	N/A	100kA	500				

* 25kA @ 600Vac, 100kA @ 480Vac.

UL 98 Enclosed Non-Fused Disconnects—30 to 1200A

Enclosure Weights - Lbs & Dimensions - in

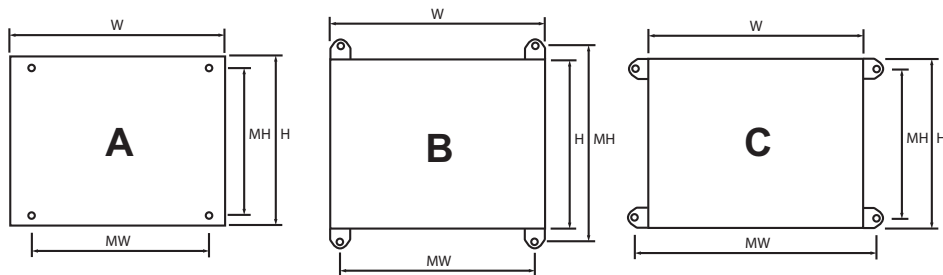

Part Number Family	Amp Rating	NEMA Enclosure Type	H x W x D	Mounting Centers H x W			Weight Lbs
				A	B	C	
ER_-30	30	1, 3R, 4, 12	10x8x6	8.3x6.3			11
		4X-SST	10x8x6		9.5x6.3	8.3x7.5	11
		4X-Plastic ⁽¹⁾	9x9x6		10x3.6	5.6x8	5
ER_-60	60	1, 3R, 4, 12	10x8x6	8.3x6.3			12
		4X-SST	10x8x6		9.5x6.3	8.3x7.5	12
		4X-Plastic ⁽¹⁾	9x9x6		10x3.6	5.6x8	5
ER_-100	100	1, 3R, 4, 12	12x10x6	10.3x8.3			12
		4X-SST	12x10x6		11.5x8.3	0.3x9.5	12
		4X-Plastic ⁽¹⁾	13x13x6		14x7.6	9.6x12	8
ER_-200	200	1, 3R, 4, 12	20x16x8	18.1x14.2			39
		4X-SST	20x16x8		19.3x14.2	18.1x15.4	39
		4X-Plastic ⁽¹⁾	23x17x12		21.5x10.1		31
ER_-400	400	1, 3R, 4, 12	36x30x8	33.9x28.3			122
		4X-SST	36x30x8		35.1x28.3	33.9x29.5	122
		4X-Plastic ⁽¹⁾	40x32x14		38.1x23.9		103
ER_-600	600	1, 3R, 4, 12	48x36x12	45.8x34.9			209
		4X-SST	48x36x12		47x34.9	45.8x36.1	209
		4X-Plastic ⁽¹⁾	51x37x 14		50.1x28.5		187
ER_-800	800	1, 3R, 4, 12	48x36x12	45.8x34.9			211
		4X-SST	48x36x12		47x34.9	45.8x36.1	211
		4X-Plastic ⁽¹⁾	51x37x 14		50.1x28.5		189
ER_-1200	1200	1, 3R, 4, 12	60x36x16	57.5x33.9			268
		4X-SST	60x36x16		58.7x33.9	57.5x35.1	268

(1) Enclosures ≤100A are polycarbonate, flammability rating UL 94-5VA-V0, ≥200A are fiberglass, flammability rating UL 94-5V.

Available Field-Installed Accessories - Order Separately

Switch Amp Rating	Auxiliary Contacts - for 30 to 1200 Amp Switches						
	Contact Type	Number of Contacts	Continuous Amp Rating	Voltage Rating	Max Number of Aux Contacts per Switch	Part Number	
30-100	NO + NC	1 of each	10A	240Vac	4	BAC01	
30-100	NC	2	10A	240Vac	4	BAC02	
100-1200	NO + NC	1 of each	10.1A	125-250Vac	2	BAC03*	
100-1200	NO + NC	1 of each	10.1A	125-250Vac	2	BAC04*	
100-1200	NO + NC	1 of each	1A	125Vac	2	BAC11*	
100-1200	NO + NC	1 of each	1A	125Vac	2	BAC12*	

* For one auxiliary contact, install either BAC03 or BAC11. For two auxiliary contacts, install BAC03 + BAC04, or BAC11 + BAC12.

Switch Amp Rating	Terminal Shrouds - for 200 to 800 Amp Switches			
	Number of Poles	Location on Switch	Part Number	
30-100	3	Lineside and Loadside	TSH3-3TB	
200A	3	Lineside	TSH4-3T	
200A	3	Loadside	TSH4-3B	
400A	3	Lineside	TSH5-3T	
400A	3	Loadside	TSH5-3B	
600A	3	Lineside or Loadside	TSH6-3TB	
800-1200A	3	Lineside or Loadside	TSH7-3TB	

Disconnect Switches

UL 508 Enclosed Non-Fused Disconnects—16 to 80A

3-/6-Pole UL 508 600Vac

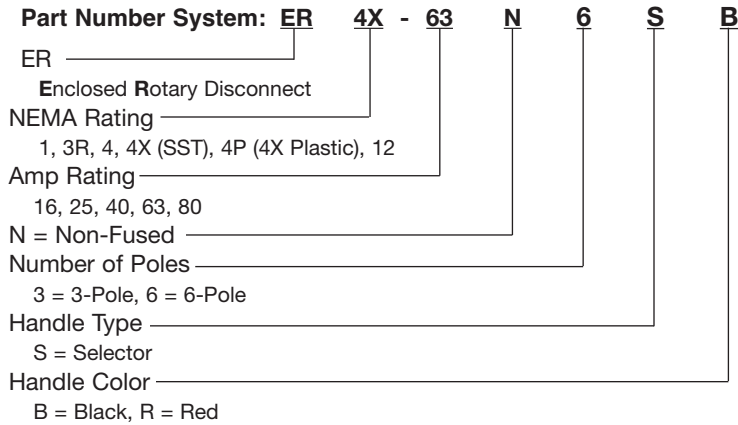

Part Numbers - All part numbers provided with a black selector handle. Order red/yellow handle by changing the suffix "B" to "R."

UL General Purpose Amp Rating	No. of Poles	NEMA Enclosure Type & Part Number					
		1	3R	4	4X Plastic ⁽¹⁾	4X Stainless	12
16	3	ER1-16N3SB	ER3R-16N3SB	ER4-16N3SB	ER4P-16N3SB	ER4X-16N3SB	ER12-16N3SB
	6	ER1-16N6SB	ER3R-16N6SB	ER4-16N6SB	ER4P-16N6SB	ER4X-16N6SB	ER12-16N6SB
25	3	ER1-25N3SB	ER3R-25N3SB	ER4-25N3SB	ER4P-25N3SB	ER4X-25N3SB	ER12-25N3SB
	6	ER1-25N6SB	ER3R-25N6SB	ER4-25N6SB	ER4P-25N6SB	ER4X-25N6SB	ER12-25N6SB
40	3	ER1-40N3SB	ER3R-40N3SB	ER4-40N3SB	ER4P-40N3SB	ER4X-40N3SB	ER12-40N3SB
	6	ER1-40N6SB	ER3R-40N6SB	ER4-40N6SB	ER4P-40N6SB	ER4X-40N6SB	ER12-40N6SB
63	3	ER1-63N3SB	ER3R-63N3SB	ER4-63N3SB	ER4P-63N3SB	ER4X-63N3SB	ER12-63N3SB
	6	ER1-63N6SB	ER3R-63N6SB	ER4-63N6SB	ER4P-63N6SB	ER4X-63N6SB	ER12-63N6SB
80	3	ER1-80N3SB	ER3R-80N3SB	ER4-80N3SB	ER4P-80N3SB	ER4X-80N3SB	ER12-80N3SB
	6	ER1-80N6SB	ER3R-80N6SB	ER4-80N6SB	ER4P-80N6SB	ER4X-80N6SB	ER12-80N6SB

(1) Polycarbonate enclosure flammability rating UL 94-5VA-V0.

Switch Ratings - for wire types, ranges and tightening torques, see table on page 413

Switch Amp Rating	Disconnect Switch	Voltage		SCCR with Max Upstream Class J Fuse	Max Hp Rating @ 600Vac
		Vac	Vdc		
16	RD16-3-508	600	N/A	65kA / 30A	10
25	RD25-3-508			65kA / 30A	20
40	RD40-3-508			65kA / 30A — 10kA / 60A	25
63	RD63-3-508			65kA / 60A — 50kA / 100A	40
80	RD80-3-508			65kA / 60A — 50kA / 100A	40

Note: Voltage, SCCR and Horsepower ratings are the same for 3- and 6-pole UL 508 non-fused disconnect switches.

UL 508 Enclosed Non-Fused Disconnects—16 to 80A

Enclosure Weights - Lbs & Dimensions - in

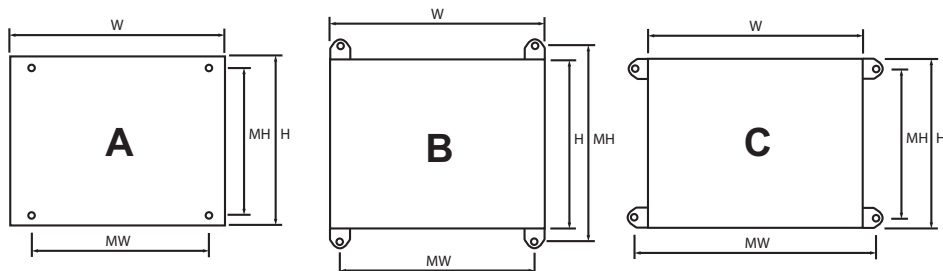

NEMA Enclosure Type	No. of Poles	Switch Amp Ratings	H x W x D	Mounting Centers H x W			Weight Lbs
				A	B	C	
1, 3R, 4, 12	3	16-80A	8x6x6	6.3x4.3			8
	6	16-80A	10x8x6	8.3x6.3			11
4X-SST	3	16-80A	8x6x6		7.5x4.3	6.3x5.5	8
	6	16-80A	10x8x6		9.5x6.3	8.3x7.5	11
4X-Plastic ⁽¹⁾	3	16-63A	7.4x8.7x5.8	8x3.6	3.6x8		4
		80A	9.4x8.7x5.9	10x3.6	5.6x8		5
	6	16-80A	11.4x10.7x6.3	12x5.6	7.64x10		6

(1) Polycarbonate.

Disconnect Switches

Available Field-Installed Accessories - Order Separately

	Auxiliary Contacts					
	Contact Type	Number of Contacts	Continuous Amp Rating	Voltage Rating	Max Number of Aux Contacts per Switch	Part Number
	NO + NC	1 Ea	10A	240Vac	4	BAC01
NO	2	10A	240Vac	4	BAC02	

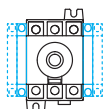

Auxiliary Contact Configurations

	Terminal Shrouds - includes terminal shroud for both lineside <i>and</i> loadside				
	Switch Amp Rating	Number of Poles		Location on Switch	Part Number
	16-40A	3		Lineside and Loadside	TSH1-3TB
63-80A	3		Lineside and Loadside	TSH2-3TB	

	Switched 4 th Pole - converts 3-pole switch to 4-pole switch	
	Switch Amp Rating	Part Number
	16	POLE-16
	25	POLE-25
40	POLE-40	

Fused, Dead Front Disconnect Switches

15149 Series

Specifications

Description: Fused, dead front disconnect switches

Ratings:

Volts: — 600Vac

Amps: — 0-30A

SCCR: — 200kA RMS Sym.

Dielectric SCCR: 2200V

Motor Rating: 5Hp

Poles: 2 to 3

Agency Information: UL Recognized, file E120756 for General Industrial installations. Guide WGEU2. CSA certified, file LR37129-6. Examined under the new proposed standard UL 1429 which imparts a stricter set of test conditions than the former program that combined the applicable portions for UL 512 (Fuse Holders) and UL 98 (Enclosed Switches).



Features and Benefits

- Fuse holders in the pull-out head eliminate possibility of electric shock while changing fuse.
- Accepts Class J fuses

Ordering Information

To order, specify: 15149 + number of poles.

Example: 15149-2 = 2-pole device.



Flexibility and Convenience Make Point-of-Use Configuration Easy



Full range of open disconnect switches with versatile options and accessories that ship within 24 hours

www.cooperbussmann.com