

Bulk Metal® Foil Technology High Precision, Current Sensing, Power Surface Mount, Metal Strip Resistor with Improved Stability 0.05 %, Resistance Value from 10 mΩ, Rated Power to 2 W and TCR to $0 \pm 20 \text{ ppm}/^\circ\text{C}$

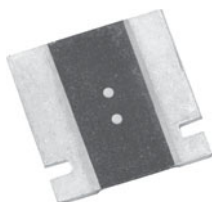

INTRODUCTION

The CSM3637S is a low value current sense resistor, providing power and precision in a four terminal, surface mount configuration. Its all welded construction is made up of a Bulk Metal® resistive element with plated copper terminations.

There are many current sense resistors on the market, until now the combination of very stable and precise resistors with low TCR as much as $0 \text{ ppm}/^\circ\text{C} \pm 20 \text{ ppm}/^\circ\text{C}$, tight tolerance of $\pm 0.2 \%$ and excellent load life stability of $\pm 0.05 \%$ (2000 h, $+ 70^\circ\text{C}$ at rated power) were not easily available.

The key performance of the new CSM3637S is stability, which is the ability of this resistor to maintain its value with time under nominal load at various environmental conditions.

These specifications are based on tests performed in accordance with methods prescribed by appropriate MIL-PRF standards.

The four terminal device separates the current leads from the voltage drop sensing leads. This configuration eliminates the effect of the lead wire resistance from points A to B and C to D.

A key feature of the CSM3637S is its low thermal EMF design. The welded terminals make intimate contact with the chip thereby minimizing temperature variations.

Vishay Foil Resistors' application engineering department is available to advise and make recommendations.

For non-standard technical requirements and special applications, please contact: foil@vishaypg.com

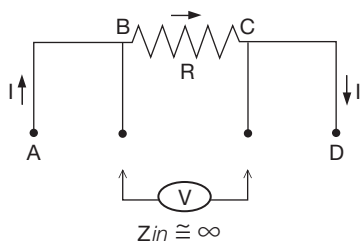

FEATURES

- Temperature coefficient of resistance (TCR): ($- 55^\circ\text{C}$ to $+ 125^\circ\text{C}$, $+ 25^\circ\text{C}$ ref.) $\pm 20 \text{ ppm}/^\circ\text{C}$ maximum
- Load life stability to $\pm 0.05 \%$ (70°C , 2000 h at rated power)
- Power rating: 2 W
- Resistance tolerance: $\pm 0.2 \%$
- Resistance range: 10 mΩ to 100 mΩ
- Vishay Foil resistors are not restricted to standard values; specific "as required" values can be supplied at no extra cost or delivery (e.g. 10.2345 mΩ vs. 10 mΩ)
- Short time overload: 0.1 %
- Proprietary processing technique produces extremely low resistance values with improved stability
- All welded construction
- Solderable terminations
- Very low inductance 0.5 nH to 5 nH
- Excellent frequency response to 50 MHz
- Low thermal EMF ($< 3 \mu\text{V}/^\circ\text{C}$)
- Maximum current: up to 14 A
- Four terminal (Kelvin) design: allows for precise and accurate measurements
- Terminal finishes available: lead (Pb)-free or tin/lead alloy
- Prototype quantities available in just 5 working days or sooner. For more information, please contact foil@vishaypg.com
- **Screening in accordance with EEE-INST002 available (per MIL-PRF-55342 and MIL-PRF-49465; see 303144 and 303145 datasheets)**
- For better performances please contact Application Engineering



RoHS*
COMPLIANT

FIGURE 1 - POWER DERATING CURVE

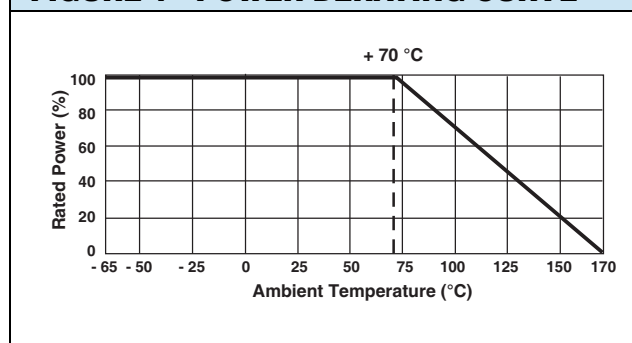

* Pb containing terminations are RoHS compliant, exemptions may apply

TABLE 1 - PERFORMANCE SPECIFICATIONS

PARAMETER	CSM3637S
Resistance Range	10 mΩ to 100 mΩ
Power Rating at 70 °C	2 W
Maximum Current	14 A
Tightest Tolerance	± 0.2 %
Temperature Coefficient Maximum (- 55 °C to + 125 °C, + 25 °C ref.)	± 20 ppm/°C
Operating Temperature Range	- 65 °C to + 170 °C
Weight (maximum)	0.29 g

FIGURE 2 - DIMENSIONS AND IMPRINTING in inches (millimeters)

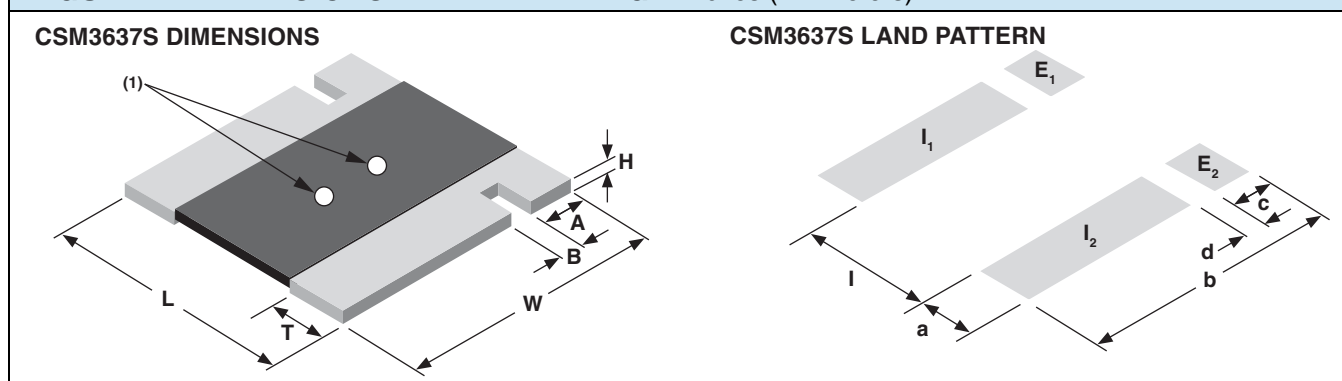

DIMENSIONS - TOLERANCES ± 0.010 (± 0.254)

RESISTANCE RANGE (mΩ)	L	W	H	T	A	B
10 to 100	0.360 (9.144)	0.370 (9.398)	0.025 (0.635)	0.086 (2.184)	0.061 (1.549)	0.032 (0.813)

LAND PATTERN DIMENSIONS - TOLERANCES ± 0.003 (± 0.076)

RESISTANCE RANGE (mΩ)	i	b	-	a	c	d
10 to 100	0.178 (4.52)	0.390 (9.91)	-	0.116 (2.95)	0.066 (1.68)	0.024 (0.610)

Note

(1) White dots indicate top side of part for mounting purposes

TABLE 2 - CSM3637S PERFORMANCE SPECIFICATIONS

TEST	CONDITIONS	MIL-PRF-49465B ΔR LIMITS	TYPICAL ΔR LIMITS	MAXIMUM ΔR LIMITS
Thermal Shock	- 55 °C to + 150 °C, 1000 cycles, 15 min at each extreme	± (0.5 % + 0.0005R)	0.1 %	0.2 %
Load Life Stability	2000 h, 70 °C at rated power	± (1.0 % + 0.0005R)	0.05 %	0.2 %
Bias Humidity	85 °C, 85 % humidity, 10 % bias, 1000 h	± (0.5 % + 0.0005R)	0.05 %	0.2 %
Short Time Overload	5 x rated power for 5 s	± (0.5 % + 0.0005R)	0.1 %	0.2 %
High Temperature Exposure	1000 h, 170 °C	± (1.0 % + 0.0005R)	0.2 %	0.3 %
Low Temperature Storage	MIL-PRF-49465	± (0.5 % + 0.0005R)	0.05 %	0.1 %
Moisture Resistance	MIL-STD-202, method 106, 0 % power, 7a and 7b not required	± (0.5 % + 0.0005R)	0.02 %	0.05 %
Shock	100 g, 6 ms	± (0.1 % + 0.0005R)	0.02 %	0.05 %
Vibration	(10 Hz to 2000 Hz) 20 g	± (0.1 % + 0.0005R)	0.02 %	0.05 %
Resistance to Soldering Heat	10 s to 12 s at + 260 °C	± (0.25 % + 0.0005R)	0.05 %	0.1 %
Solderability	MIL-STD-202	95 % coverage	-	

Note

- Measurement error 0.0005R per MIL-PRF-49465

CSM3637S CONSTRUCTION

1. Resistive element
2. Copper terminal with solderable finish
3. Terminal-to-element weld
4. High temperature encapsulation

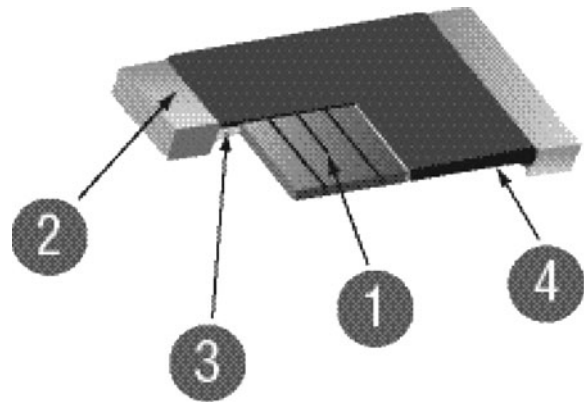
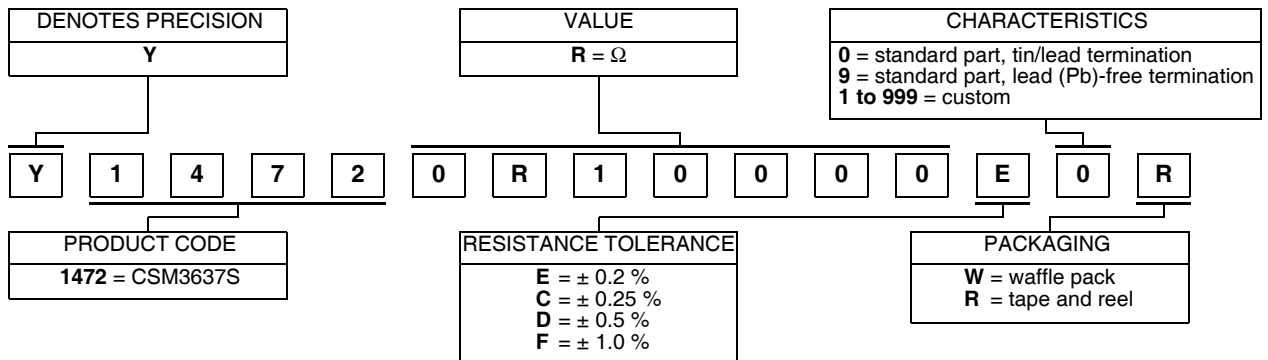

TABLE 3 - GLOBAL PART NUMBER INFORMATION (1)

NEW GLOBAL PART NUMBER: Y14720R10000E0R (preferred part number format)



FOR EXAMPLE: ABOVE GLOBAL ORDER Y1472 0R10000 E 0 R:

TYPE: CSM3637S
 VALUE: 100.0 mΩ
 ABSOLUTE TOLERANCE: ± 0.2 %
 TERMINATION: standard tin/lead
 PACKAGING: tape and reel

HISTORICAL PART NUMBER: CSM3637S 0R1000 E B T (will continue to be used)

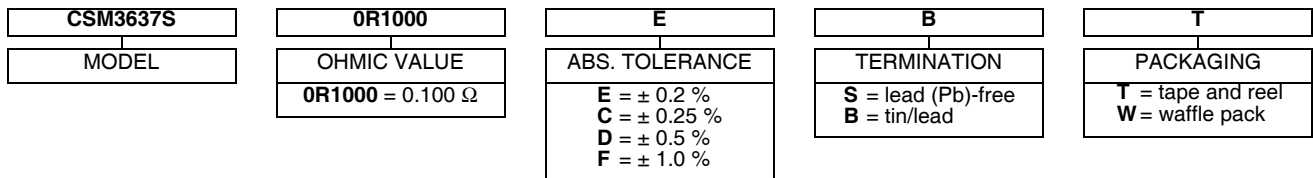

Note

(1) For non-standard requests, please contact application engineering.

Disclaimer

ALL PRODUCTS, PRODUCT SPECIFICATIONS AND DATA ARE SUBJECT TO CHANGE WITHOUT NOTICE.

Vishay Precision Group, Inc., its affiliates, agents, and employees, and all persons acting on its or their behalf (collectively, "Vishay Precision Group"), disclaim any and all liability for any errors, inaccuracies or incompleteness contained herein or in any other disclosure relating to any product.

The product specifications do not expand or otherwise modify Vishay Precision Group's terms and conditions of purchase, including but not limited to, the warranty expressed therein.

Vishay Precision Group makes no warranty, representation or guarantee other than as set forth in the terms and conditions of purchase. **To the maximum extent permitted by applicable law, Vishay Precision Group disclaims (i) any and all liability arising out of the application or use of any product, (ii) any and all liability, including without limitation special, consequential or incidental damages, and (iii) any and all implied warranties, including warranties of fitness for particular purpose, non-infringement and merchantability.**

Information provided in datasheets and/or specifications may vary from actual results in different applications and performance may vary over time. Statements regarding the suitability of products for certain types of applications are based on Vishay Precision Group's knowledge of typical requirements that are often placed on Vishay Precision Group products. It is the customer's responsibility to validate that a particular product with the properties described in the product specification is suitable for use in a particular application.

No license, express, implied, or otherwise, to any intellectual property rights is granted by this document, or by any conduct of Vishay Precision Group.

The products shown herein are not designed for use in life-saving or life-sustaining applications unless otherwise expressly indicated. Customers using or selling Vishay Precision Group products not expressly indicated for use in such applications do so entirely at their own risk and agree to fully indemnify Vishay Precision Group for any damages arising or resulting from such use or sale. Please contact authorized Vishay Precision Group personnel to obtain written terms and conditions regarding products designed for such applications.

Product names and markings noted herein may be trademarks of their respective owners.