

PICK-OFF TRANSFORMER**P1727****Features**

- * 12.6mm (0.5") seated height
- * Lead-free (Pb-free)
- * RoHS compliant
- * Vacuum encapsulated
- * IEC 60950 and UL 60950 certified
- * UL Recognized Component

Applications

- * Telecommunications
- * Pick-off applications
- * Calling Line Identification
- * Instrumentation
- * Voice Recording

DESCRIPTION

P1727 is a high impedance transformer for applications where high performance and safety isolation to international standards are required in a compact case size.

P1727 has a turns ratio of 2.162:1 giving an impedance transformation of 4.67:1.

P1727 is designed for "listening" applications when placed across a line, presenting a very high impedance to minimize circuit loading.

P1727 is certified to IEC 60950 and UL 60950. P1727 is a UL Recognized Component and is supported by an IEC CB Test Certificate. The part is completely lead-free, compliant with RoHS Directive 2002/95/EC, and suitable for lead-free and conventional processing.

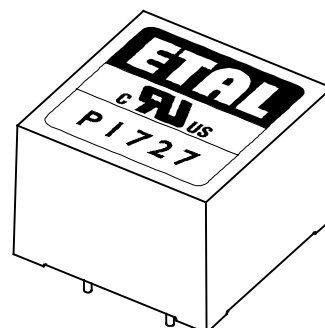

SPECIFICATIONS**Electrical**

At T = 25°C unless otherwise stated.

Parameter	Conditions	Min	Typ	Max	Units
Voltage isolation ⁽¹⁾	50Hz	3.88	-	-	kVrms
	DC	5.5	-	-	kV
Balance	DC – 5kHz Method TG25	50	-	-	dB
Input impedance	200Hz – 4kHz, Fig 2	12	-	-	kΩ
Operating range:	Ambient temperature				
Functional		-25	-	+85	°C
Storage		-40	-	+125	°C
Humidity		-	-	95	%R.H.

Lumped equivalent circuit parameters as Fig. 1

DC resistance, R_{DC} ⁽²⁾	Sum of windings (Corrected for ratio)	-	-	1537	Ω
Leakage inductance ΔL	Referred to pins 1-3	-	-	160	mH
Shunt inductance L_p	10mV 200Hz	22	-	-	H
Shunt loss R_p	10mV 200Hz	50	-	-	kΩ

Notes

1. Components are 100% tested at 6.5kV DC.
2. Caution: do not pass DC through windings. Telephone line current, etc. must be diverted using choke or semiconductor line hold circuit.

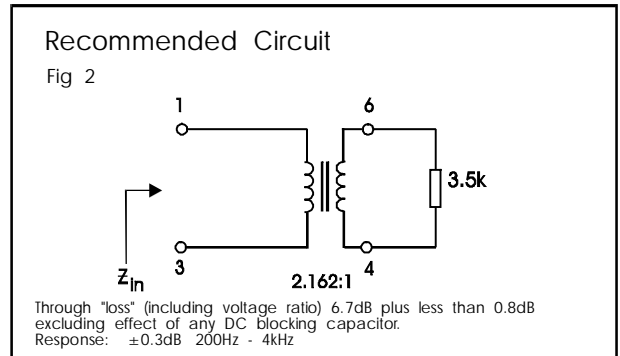
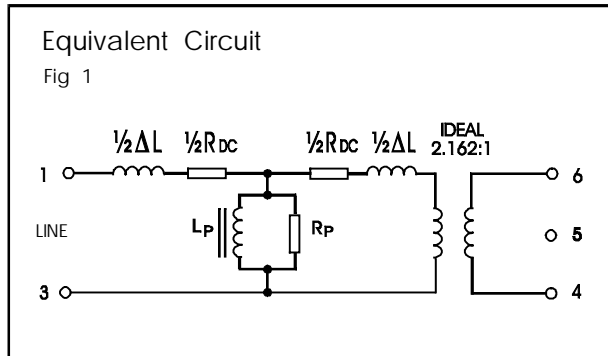

CONSTRUCTION

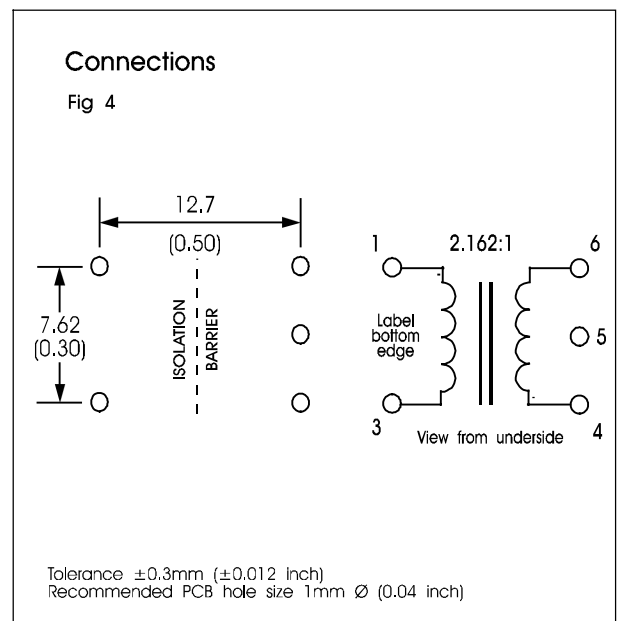
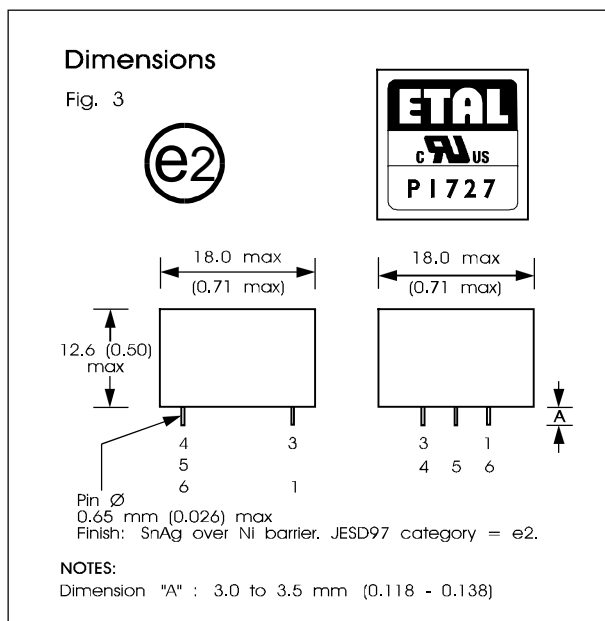

Dimensions shown are in millimetres (inches).
Geometric centres of outline and pin grid coincide within a tolerance circle of 0.6mm

SAFETY

Constructed in accordance with IEC 60950-1:2001, EN 60950-1:2001 and UL 60950-1 First Edition, supplementary insulation, 250Vrms maximum working voltage, flammability class V-0. Distances through solid insulation 0.4mm minimum.

CERTIFICATION

Certified under the IEC CB scheme (Certificate DK-9431) to IEC 60950-1:2001, sub-clauses 1.5, 1.5.1, 1.5.2, 1.7, 1.7.1, 2, 2.9, 2.9.1, 2.9.2, 2.9.3, 2.10, 2.10.1, 2.10.2, 2.10.3, 2.10.3.1, 2.10.3.3, 2.10.4, 2.10.5, 2.10.5.1, 2.10.5.4, 4, 4.7, 4.7.1, 4.7.3, 4.7.3.1, 4.7.3.4, 5, 5.2, 5.2.1, and 5.2.2 for a maximum working voltage of 250Vrms, nominal mains supply voltage not exceeding 300Vrms and a maximum operating temperature of 85°C in Pollution Degree 2 environments, supplementary insulation, including national differences for Denmark, Finland, Germany, Norway, Sweden, Switzerland, USA, Canada and UK. Recognized under the Component Recognition Program of Underwriters Laboratories Inc. to US and Canadian requirements CAN/CSA C22.2 No. 60950-1-03/UL60950-1, First Edition, based on IEC 60950-1, First Edition, maximum working voltage 250Vrms, Pollution Degree 2, reinforced insulation.

UL File number E203175.

Additionally, Profec Technologies certifies all transformers as providing voltage isolation of 3.88kVrms, 5.5kV DC minimum. All shipments are supported by a certificate of conformity to current applicable safety standards.

ABSOLUTE MAXIMUM RATINGS

(Ratings of components independent of circuit).

Short term isolation voltage (15s)	4.6kVrms, 6.5kV DC
DC current	100µA
Storage temperature	-40°C to +125°C
Lead temperature, 10s	260°C

COPYRIGHT

ETAL and P1727 are Trade Marks of Profec Technologies Ltd. The Trade Mark ETAL is registered at the UK Trade Marks Registry.

Profec Technologies Ltd. is the owner of the design right under the Copyright Designs and Patents Act 1988 and no rights or licences are hereby granted or implied to any third party.

© 1996 – 2006 Profec Technologies Ltd.
Reproduction prohibited.



ISO 9001
FM 25326

Profec Technologies Ltd., 10 Betts Avenue, Martlesham Heath, Ipswich, IP5 3RH, England
Telephone: +44 (0) 1473 611422 Fax: +44 (0) 1473 611919
Website: www.profec.com Email: info@profec.co.uk sales@profec.com